

CECW-ED Engineer Manual 1110-2-2502	Department of the Army U.S. Army Corps of Engineers Washington, DC 20314-1000	EM 1110-2-2502 29 September 1989
	Engineering and Design RETAINING AND FLOOD WALLS	
	Distribution Restriction Statement Approved for public release; distribution is unlimited.	



US Army Corps
of Engineers

EM 1110-2-2502
29 Sept 1989

ENGINEERING AND DESIGN

Retaining and Flood Walls

ENGINEER MANUAL

CECW-ED
CECW-EG

Engineer Manual
No. 1110-2-2502

29 September 1989

Engineering and Design
RETAINING AND FLOOD WALLS

1. Purpose. This manual provides guidance for the safe design and economical construction of retaining and flood walls. This manual is intended primarily for retaining walls which will be subjected to hydraulic loadings such as flowing water, submergence, wave action, and spray, exposure to chemically contaminated atmosphere, and/or severe climatic conditions. For the design of retaining walls which will not be subjected to hydraulic loadings or severe environmental conditions as described above, TM 5-818-1 may be used for computing the loadings and evaluating the stability of the structure.

2. Applicability. This manual applies to all HQUSACE/OCE elements and field operating activities having responsibilities for the design of civil works projects.

FOR THE COMMANDER:

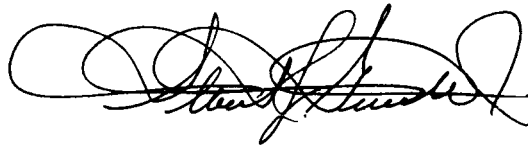

Albert J. Genetti, Jr.
Colonel, Corps of Engineers
Chief of Staff

This manual supersedes EM 1110-2-2501 dated January 1948 and EM 1110-2-2502 dated 29 May 1961.

CECW-ED
 CECW-EG

Engineer Manual
 No. 1110-2-2502

29 September 1989

Engineering and Design
 RETAINING AND FLOOD WALLS

Table of Contents

Subject		Paragraph	Page
CHAPTER 1.	INTRODUCTION		
	Purpose	1-1	1-1
	Applicability	1-2	1-1
	References and Bibliography	1-3	1-1
	Terms	1-4	1-1
	Scope	1-5	1-1
CHAPTER 2.	GENERAL DESIGN CONSIDERATIONS		
Section I.	Types of Retaining Walls		
	Common Types of Retaining Walls	2-1	2-1
	Gravity Concrete Wall	2-2	2-1
	Cantilever Reinforced Concrete Wall	2-3	2-1
	Alternate Types of Retaining Walls	2-4	2-1
Section II.	Types of Flood Walls		
	Common Types of Flood Walls	2-5	2-1
	Cantilever T-Type Wall	2-6	2-4
	Cantilever I-Type Wall	2-7	2-4
	Other Types of Flood Walls	2-8	2-4
Section III.	Differences Between Retaining and Flood Walls		
	Purpose of Walls	2-9	2-4
	Seepage and Leakage Control Requirements	2-10	2-4
	Wall Stability	2-11	2-6
	Special Flood Wall Monoliths	2-12	2-6
	Design Philosophy	2-13	2-6
	Stability Considerations	2-14	2-6
Section IV.	Coordination Between Disciplines		
	Engineering Team	2-15	2-6
Section V.	Geotechnical Investigations		
	Planning the Investigation	2-16	2-7
	Foundation Exploration and Site Characterization	2-17	2-7
	Testing of Foundation Materials	2-18	2-8
	In Situ Testing of Foundation Materials	2-19	2-10
	Backfill Materials	2-20	2-15
	Design Strength Selection	2-21	2-15

	<u>Subject</u>	<u>Paragraph</u>	<u>Page</u>
CHAPTER 3.	FORCES ON WALLS		
Section I.	Introduction		
	General	3-1	3-1
	Limit-Equilibrium Analysis	3-2	3-1
	Relationship of Forces to Sliding Analysis	3-3	3-1
Section II.	Earth Pressures and Forces		
	Cohesionless Materials	3-4	3-2
	Cohesive Materials	3-5	3-5
	Pressures in Soil-Water Systems	3-6	3-6
	Design Earth Pressures and Forces, Driving Side	3-7	3-6
	Design Earth Pressures and Forces, Resisting Side	3-8	3-8
	Design Earth Pressures and Forces on the Base	3-9	3-9
	At-Rest Earth Pressure Equations	3-10	3-11
	Strength Mobilization Factor	3-11	3-13
	Earth Force Calculation, Coulomb's Equations	3-12	3-17
	Earth Force Calculation, General Wedge Method	3-13	3-23
	Earth Pressure Calculations Including Wall Friction	3-14	3-37
	Distribution of Horizontal Earth Pressure	3-15	3-38
	Surcharge Effects	3-16	3-45
	Earth Pressures Due to Compaction	3-17	3-47
Section III.	Water Pressures		
	Pressure Calculations	3-18	3-53
	Seepage Analysis by Line-of-Creep Method	3-19	3-55
	Seepage Analysis by Method of Fragments	3-20	3-55
	Seepage Analysis by the Finite Element Method	3-21	3-58
	Uplift Calculations for Rock Foundations	3-22	3-58
	Effect of Drains	3-23	3-59
	Surge and Wave Loads	3-24	3-59
Section IV.	Supplemental Forces		
	Wind Load	3-25	3-61
	Earthquake Forces	3-26	3-61
CHAPTER 4.	STRUCTURE STABILITY		
Section I.	Scope	4-1	4-1
	Loading Conditions		
	Representative Loading Conditions	4-2	4-1
	Retaining Walls	4-3	4-1
	Inland Flood Walls	4-4	4-1
	Coastal Flood Walls	4-5	4-2
Section II.	Stability Considerations		
	General Requirements	4-6	4-3
	Stability Criteria	4-7	4-3

	Subject	Paragraph	Page
Section III.	Overturning Stability		
	Resultant Location	4-8	4-3
	Overturning Stability Criteria	4-9	4-15
Section IV.	Structure Sliding Stability		
	Overview of Sliding Stability Analysis	4-10	4-15
	Sliding Factor of Safety	4-11	4-17
	Assumptions and Simplifications	4-12	4-18
	General Wedge Equation	4-13	4-20
	Slip-Plane Angle	4-14	4-23
	Single Wedge Analysis	4-15	4-24
	Multiple Wedge Analysis	4-16	4-25
	Sliding Stability Criteria	4-17	4-27
	Design Considerations	4-18	4-27
Section V.	Bearing Capacity Analysis		
	General Computations	4-19	4-28
	Inadequate Bearing Capacity	4-20	4-28
	Bearing Capacity Criteria	4-21	4-28
Section VI.	Summary of Design Procedures		
	Design Procedures	4-22	4-28
CHAPTER 5.	FOUNDATION ANALYSES		
Section I.	Bearing Capacity of Wall Foundations		
	Analysis Principles and Methods	5-1	5-1
	General Bearing Capacity Equation	5-2	5-1
	Bearing Capacity Factors	5-3	5-2
	Embedment Factors	5-4	5-4
	Inclination Factors	5-5	5-4
	Base Tilt Factors	5-6	5-7
	Ground Slope Factors	5-7	5-7
	Effective Overburden Pressure	5-8	5-7
	Combination of Factors	5-9	5-8
	Example	5-10	5-8
Section II.	Other Considerations		
	Settlement	5-11	5-8
	Deep-Seated Sliding	5-12	5-8
	Liquefaction Susceptibility	5-13	5-11
CHAPTER 6.	DESIGN AND CONSTRUCTION DETAILS AND CAUSES OF UNSATISFACTORY PERFORMANCE		
	Foundation Preparation	6-1	6-1
	Concrete Mixture Proportions	6-2	6-1
	Constructability	6-3	6-1
	Joints	6-4	6-1
	Soil Backfill	6-5	6-3
	Drainage	6-6	6-4
	Causes of Unsatisfactory Performance	6-7	6-15

	<u>Subject</u>	<u>Paragraph</u>	<u>Page</u>
CHAPTER 7.	SPECIAL CONSIDERATIONS FOR FLOOD WALLS		
Section I.	General Characteristics		
	Introduction	7-1	7-1
	Rationale for Loading Cases	7-2	7-1
Section II.	Seepage Control		
	General Considerations	7-3	7-3
	Underseepage Control	7-4	7-3
Section III.	Foundation Considerations		
	Base Types	7-5	7-10
	Horizontal Water and Earth Loads on Keys	7-6	7-10
	Unsuitable Foundation Material and Bank Stability	7-7	7-10
	Scour Protection	7-8	7-13
Section IV.	Types of Monoliths		
	Change-of-Alignment Monoliths	7-9	7-13
	Closure and Abutment Monoliths	7-10	7-13
	Drainage Structure Monoliths	7-11	7-13
	Transition Sections Between Flood Walls and Levees	7-12	7-13
Section V.	Water Stops and Joints		
	Water Stops	7-13	7-17
	Contraction and Expansion Joints	7-14	7-17
Section VI.	Site Considerations		
	Adjacent Structures and Rights-of-Way	7-15	7-21
	Architectural and Landscaping Considerations	7-16	7-22
Section VII.	Instrumentation		
	General and Specific Considerations	7-17	7-22
	Types of Instrumentation	7-18	7-23
Section VIII.	Operation and Maintenance Manual Requirements		
	General Coverage	7-19	7-24
Section IX.	Review of Existing Flood Walls		
	Inspection	7-20	7-24
	Repair Measures	7-21	7-26
CHAPTER 8.	CONCRETE GRAVITY WALLS		
	General Factors	8-1	8-1
	Foundation Investigation	8-2	8-1
	Materials	8-3	8-1
	Design	8-4	8-1
CHAPTER 9.	CANTILEVER REINFORCED CONCRETE WALLS		
	General Characteristics	9-1	9-1
	Foundation Investigation	9-2	9-1
	Materials	9-3	9-1
	Reinforcement Cover	9-4	9-1

Subject		Paragraph	Page
	Load Cases	9-5	9-1
	Structural Stability	9-6	9-1
	Structural Design	9-7	9-1
	Reinforced Concrete Design	9-8	9-3
	Foundation Analyses	9-9	9-11
CHAPTER 10.	ALTERNATE TYPES OF RETAINING WALLS		
Section I.	Introduction		
	Classes of Retaining Walls	10-1	10-1
	Alternate Types of Retaining Walls	10-2	10-1
Section II.	Mechanically Stabilized Backfill Systems		
	General Background	10-3	10-1
	Available Systems	10-4	10-1
	Advantages and Disadvantages	10-5	10-2
	Cost Considerations	10-6	10-7
	Mechanisms and Behavior	10-7	10-7
	Materials	10-8	10-9
	Design Considerations	10-9	10-10
	Construction Considerations	10-10	10-12
	Instrumentation and Monitoring	10-11	10-13
	Maintenance and Repair	10-12	10-13
Section III.	Precast Concrete Modular Systems		
	Background	10-13	10-14
	Basic Components	10-14	10-14
	Advantages and Disadvantages	10-15	10-14
	Design Considerations	10-16	10-14
	Construction Considerations	10-17	10-19
	Instrumentation and Monitoring	10-18	10-20
	Maintenance and Repair	10-19	10-20
APPENDIX A.	REFERENCES		A-1
APPENDIX B.	BIBLIOGRAPHY		B-1
APPENDIX C.	NOTATION FOR CHAPTERS 3, 4, and 5		C-1
APPENDIX D.	NOTATION FOR CHAPTER 9		D-1
APPENDIX E.	COMPARISON OF DANISH CODE AND JAKY EQUATIONS FOR AT-REST COEFFICIENT WITH COULOMB COEFFICIENT FOUND USING REDUCED SHEAR STRENGTH PARAMETER ϕ_d		E-1
APPENDIX F.	DERIVATION OF GENERAL WEDGE EQUATION FOR SINGLE WEDGE ANALYSIS (EQUATION 3-23)		F-1

	<u>Subject</u>	<u>Paragraph</u>	<u>Page</u>
APPENDIX G.	DERIVATION OF EQUATIONS FOR CRITICAL SLIP- PLANE ANGLE (α) FOR DRIVING AND RESISTING WEDGES		G-1
APPENDIX H.	DERIVATION OF PRESSURE COEFFICIENTS FOR SOLUTION OF LATERAL EARTH PRESSURE PROBLEMS		H-1
APPENDIX I.	DERIVATION OF EQUATION FOR DEPTH OF CRACK d_c IN COHESIVE SOIL		I-1
APPENDIX J.	LATERAL PRESSURES DUE TO COMPACTION		J-1
APPENDIX K.	DERIVATION OF VERTICAL SHEAR FORCE FOR UPWARD SLOPING BACKFILL		K-1
APPENDIX L.	DERIVATION OF GENERAL WEDGE EQUATION FOR MULTIPLE WEDGE ANALYSIS		L-1
APPENDIX M.	LATERAL EARTH PRESSURE COMPUTATIONS, EXAMPLES		M-1
APPENDIX N.	STABILITY, BEARING CAPACITY, AND REINFORCEMENT COMPUTATIONS, EXAMPLES		N-1
APPENDIX O.	COMPUTER PROGRAM ABSTRACTS FOR REFERENCED PROGRAMS		O-1
GLOSSARY		Glossary	1

LIST OF FIGURES

<u>Figure</u>		<u>Page</u>
2-1	Types of retaining walls	2-2
2-2	Types of flood walls	2-3
2-3	Less commonly used flood wall types	2-5
2-4	Drained friction angle versus plasticity index	2-9
2-5	SPT correction to 1 tsf (2 ksf)	2-13
2-6	ϕ' versus N' for granular materials	2-13
2-7	q_c/N versus D_{50}	2-14
2-8	Soil classification from cone penetrometer	2-14
2-9	Friction angle of granular backfills	2-16
3-1	Development of earth pressures for a cohesionless material	3-3
3-2	Relationship of earth pressures to wall movements	3-4
3-3	Vertical and horizontal pressures in a cohesionless soil mass	3-7
3-4	Forces on base of wall	3-10
3-5	Base pressures	3-12
3-6	At-rest earth pressure coefficients	3-14
3-7	Application of the strength mobilization factor	3-15
3-8	Mohr-Coulomb failure criterion	3-16
3-9	Comparison of active earth pressures	3-20
3-10	Variables used in Coulomb equation	3-21
3-11	Comparison of passive earth pressures	3-24
3-12	Wedge method on driving side	3-27
3-13	Force polygon for wedge method on driving side	3-28
3-14	Wedge analysis for irregular backfill	3-30
3-15	Surcharge effect on critical slip plane	3-32
3-16	Wedge analysis in layered soil	3-33
3-17	Wedge method for resisting-side wedge	3-36
3-18	Passive earth pressure coefficients	3-38
3-19	Lateral pressures, one soil completely above water table or completely below water table	3-40
3-20	Lateral pressures, one soil, water, finite surcharge	3-41
3-21	Lateral pressures, three soils, water	3-43
3-22	Pressure distribution due to irregular backfill	3-44
3-23	Lateral pressure distribution; active case, soil with cohesion	3-46
3-24	Lateral pressure distribution; passive case, soil with cohesion	3-47
3-25	Increase in pressure due to point load	3-48
3-26	Increase in pressure due to line load	3-49
3-27	Increase in pressure due to strip load	3-50
3-28	Resultant forces, point and line loads	3-51
3-29	Approximate line of action for line loads	3-52
3-30	Design pressure envelope for nonyielding walls with compaction effects	3-54

LIST OF FIGURES (Continued)

<u>Figure</u>		<u>Page</u>
3-31	Water pressures from flow net	3-56
3-32	Water pressure by line-of-creep method	3-57
3-33	Seepage path for line of creep	3-58
3-34	Driving and resisting seismic wedges, no saturation	3-63
3-35	Influence of k_v and β on magnification factor	3-66
3-36	Seismic wedges, water table within wedge	3-70
3-37	Static and dynamic pressure diagrams, water table within wedge	3-71
3-38	Static and dynamic pressure diagrams, cohesive fill, water table within wedge	3-75
3-39	Hydrodynamic forces for freestanding water	3-78
4-1	Stability considerations for retaining and flood walls	4-4
4-2	Forces for overturning analysis for wall with horizontal base	4-8
4-3	Forces for overturning analysis for wall with a sloping base	4-9
4-4	Relationship between base width in compression and resultant location	4-11
4-5	Forces for overturning analysis for wall with horizontal base and key	4-12
4-6	Forces for overturning analysis for wall with sloping base and key	4-13
4-7	Shear force for upward sloping backfill	4-14
4-8	Typical soil/structure system with an assumed failure surface	4-16
4-9	Free-body diagram of i^{th} wedge	4-19
4-10	Geometry of typical i^{th} wedge and adjacent wedges	4-21
4-11	Single wedge analysis of sliding stability	4-26
4-12	Wall design flowchart	4-29
5-1	Terms used in bearing capacity equation	5-3
5-2	Deep-seated sliding analysis with vertical face of driving wedge at heel	5-9
5-3	Deep-seated sliding analysis with vertical face of driving wedge at toe	5-10
5-4	Shallow shear surface	5-11
6-1	Inclined drainage blanket	6-4
6-2	Effect of drain location on excess hydrostatic pressures on the failure plane	6-6
6-3	Drainage blanket located adjacent to retaining wall	6-7
6-4	Prefabricated drainage composite used as drain adjacent to retaining wall	6-8
6-5	Drainage system to prevent frost penetration behind retaining wall	6-8
6-6	Drainage system to use with clay backfill	6-9
6-7	Inspection hole for longitudinal drain	6-10

LIST OF FIGURES (Continued)

<u>Figure</u>		<u>Page</u>
6-8	Vertical check valve at end of longitudinal drain	6-11
6-9	Approximation for estimating reduction in permeability of narrow size-ranged aggregate caused by turbulent flow	6-14
6-10	Summary of experience with unsatisfactory retaining walls	6-16
7-1	Flow around interior embedded water stop in the base	7-4
7-2	T-type flood wall--horizontal base	7-5
7-3	Uplift pressures for a wall with a sheet pile cutoff	7-7
7-4	T-type flood wall--sloped base	7-11
7-5	Removal limits of unsuitable foundation material	7-12
7-6	Return keys on reentrant monolith	7-14
7-7	Flood wall-levee transitions	7-15
7-8	Typical detail of joint between I-wall and T-wall	7-16
7-9	Typical joint and water stop details	7-18
7-10	Emergency measures to control piping	7-27
7-11	Permanent water stop repair measures	7-28
9-1	Shear force for upward-sloping backfill	9-2
9-2	Rectangular beam, simple bending with no compression reinforcement	9-7
9-3	Rectangular member, bending with small axial compression load, no compression reinforcement	9-8
9-4	Rectangular member, bending with axial tensile load, where $M_u/P_u \geq (d - h/2)$	9-9
9-5	Rectangular member, bending with axial tensile load, where $M_u/P_u < (d - h/2)$	9-10
10-1	Schematic diagram of reinforced earth retaining wall	10-3
10-2	Schematic diagram of reinforced soil embankment retaining wall	10-4
10-3	VSL retained earth retaining wall	10-5
10-4	Tensar geogrid retaining wall	10-6
10-5	Schematic diagram of Doublewal retaining wall	10-15
10-6	Materials used to construct Doublewal retaining wall	10-16
10-7	Schematic diagram of Criblock retaining wall	10-17
10-8	Schematic diagram of Evergreen retaining wall	10-18

CHAPTER 1

INTRODUCTION

1-1. Purpose.

a. General. This manual provides guidance for the safe design and economical construction of retaining and flood walls. This manual is intended primarily for retaining walls which will be subjected to hydraulic loadings such as flowing water, submergence, wave action, and spray, exposure to chemically contaminated atmosphere, and/or severe climatic conditions. For the design of retaining walls which will not be subjected to hydraulic loadings or severe environmental conditions as described above, TM 5-818-1 may be used for computing the loadings and evaluating the stability of the structure.

b. Variations from Guidance. For the evaluation of existing retaining and flood walls which have been loaded up to or above the design loads and show no displacement problems or any other sign of weakening, consideration can be given to reducing the conservatism of the criteria contained in this manual. If variations from the guidance are necessary, justification for the variations should be submitted to HQUSACE to the attention of CECW-E for approval.

1-2. Applicability. This manual applies to all HQUSACE/OCE elements and to all field operating activities having responsibilities for the design of civil works projects.

1-3. References and Bibliography. References and computer program user guides cited in this manual are listed in Appendix A. Additional reference materials pertaining to the subject matter addressed in this manual are included in Appendix B, "Bibliography." Computer program abstract descriptions are shown in Appendix O.

1-4. Terms. Special terms used in this manual are explained in the glossary.

1-5. Scope.

a. Types of Walls. This manual presents design guidance for retaining walls and inland and coastal flood walls. Retaining walls are defined as any wall that restrains material to maintain a difference in elevation. A flood wall is defined as any wall having as its principal function the prevention of flooding of adjacent land. Not specifically covered in this manual are seawalls which are defined as structures separating land and water areas, primarily designed to prevent erosion and other damage due to wave action. They are frequently built at the edge of the water, but can be built inland to withstand periods of high water. Seawalls are generally characterized by a massive cross section and a seaward face shaped to dissipate wave energy. Coastal flood walls, however, are generally located landward of the normal high water line so that they are inundated only by hurricane or other surge tide and have the smooth-faced cantilever stems shown in this manual.

29 Sep 89

b. Types of Foundations. This manual describes procedures for the design of retaining and flood walls on shallow foundations, i.e., bearing directly on rock or soil. The substructure design of pile-founded walls is not included, but is covered in EM 1110-2-2906.

c. Flood Wall Guidance. A flood wall is treated as a special case of a retaining wall. Unless specifically noted, the guidance herein applies to both retaining and flood walls.

d. Geotechnical and Structural Aspects. Both geotechnical and structural aspects of wall design are included. Coordination between geotechnical engineers, structural engineers, and geologists in the design of retaining and flood walls is essential.

CHAPTER 2

GENERAL DESIGN CONSIDERATIONS

Section I. Types of Retaining Walls

2-1. Common Types of Retaining Walls. The most common types of retaining walls are gravity concrete, cantilever T-type reinforced concrete, and cantilever and anchored sheet pile walls. Gravity and cantilever reinforced concrete walls are covered in this manual and illustrated in Figure 2-1. Alternate types of retaining walls, including mechanically stabilized backfill and precast modular gravity walls, are covered in Chapter 10. An example of one type of alternate retaining wall is shown in Figure 2-1. Counterfort and buttressed reinforced concrete walls are less commonly used and are not specifically discussed in this manual. Much of the conceptual information and the information in Chapters 3 and 9 is applicable to all types of walls.

2-2. Gravity Concrete Wall. A gravity wall (Figure 2-1) consists of mass concrete, generally without reinforcement. It is proportioned so that the resultant of the forces acting on any internal plane through the wall falls within, or close to, the kern of the section. A small tensile stress capacity is permissible for localized stresses due to extreme and temporary loading conditions.

2-3. Cantilever Reinforced Concrete Wall. A cantilever T-type reinforced concrete wall (Figure 2-1) consists of a concrete stem and base slab which form an inverted T. The structural members are fully reinforced to resist applied moments and shears. The base is made as narrow as practicable, but must be wide enough to ensure that the wall does not slide, overturn, settle excessively, or exceed the bearing capacity of the foundation. The bottom of the base should be below the zone subject to freezing and thawing or other seasonal volume changes. The T-type wall is usually the most economical type of conventional wall and is more widely used than any other type for common retaining wall heights.

2-4. Alternate Types of Retaining Walls. Retaining walls using mechanically stabilized backfill (Figure 2-1) and precast modular gravity walls can be substantially more economical to construct than conventional walls (Leary and Klinedinst 1984). However, a short life, serious consequences of failure, or high repair or replacement costs could offset a lower first cost. In addition, the design engineer must assure the overall adequacy of the design since the manufacturer of the wall may provide only that part of the design above the foundation. Chapter 10 covers mechanically stabilized backfill systems and precast modular gravity walls.

Section II. Types of Flood Walls

2-5. Common Types of Flood Walls. The most common types of flood walls are cantilever T-type and cantilever I-type walls. Examples of these walls are shown in Figure 2-2.

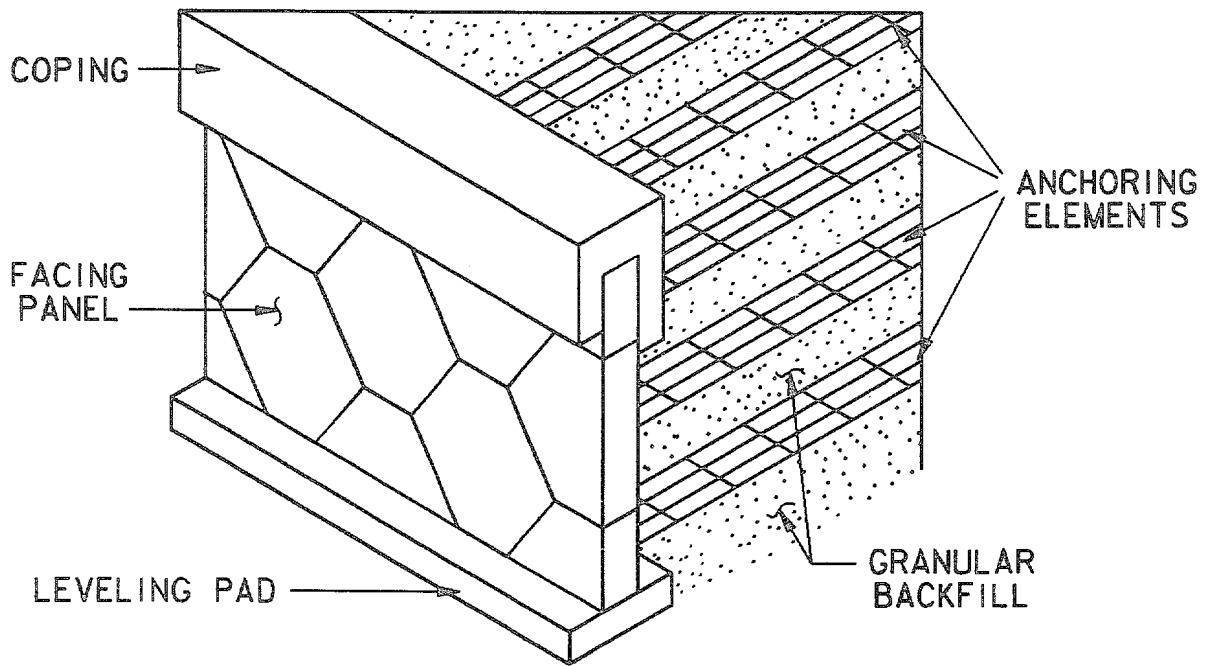
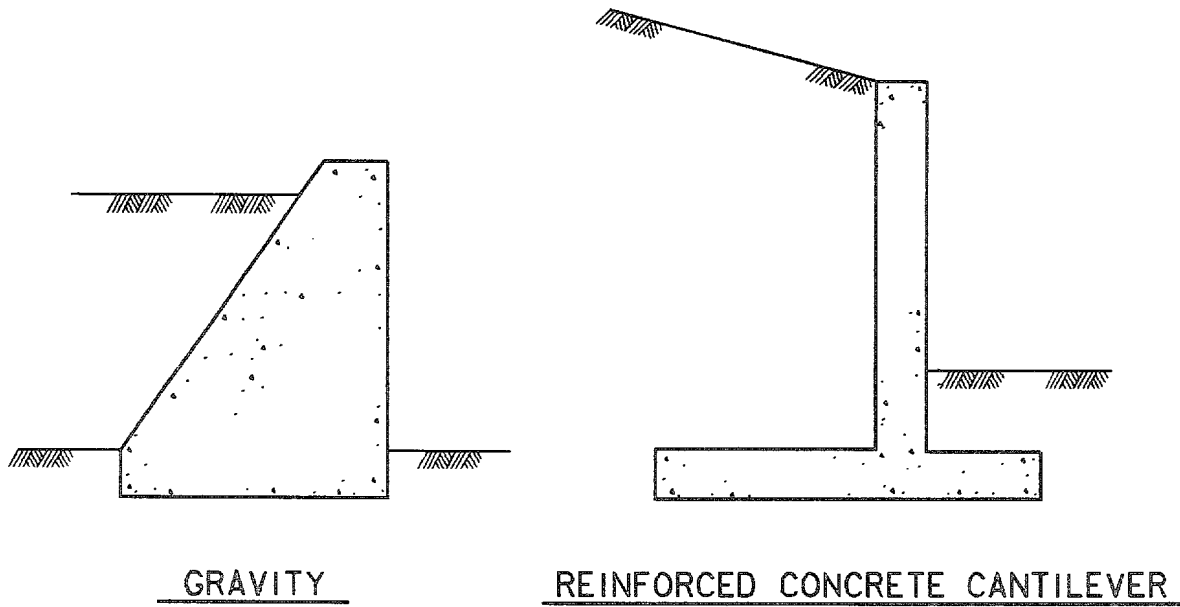

MECHANICALLY STABILIZED BACKFILL

Figure 2-1. Types of retaining walls

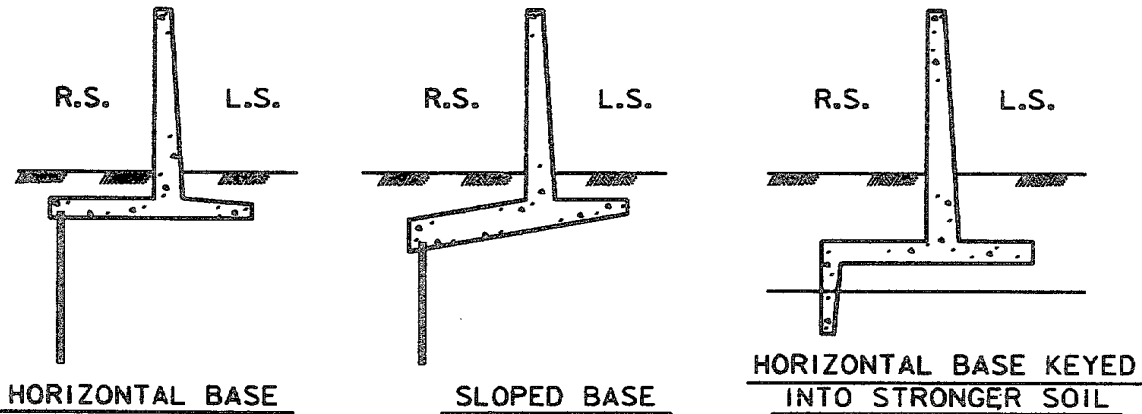

NOTE: R.S.= RIVER SIDE (OR SEAWARD, UNPROTECTED SIDE)
L.S.= LAND SIDE (OR PROTECTED SIDE)

INVERTED T-TYPE CANTILEVER WALLS



CANTILEVER I-TYPE SHEET PILE WALLS *

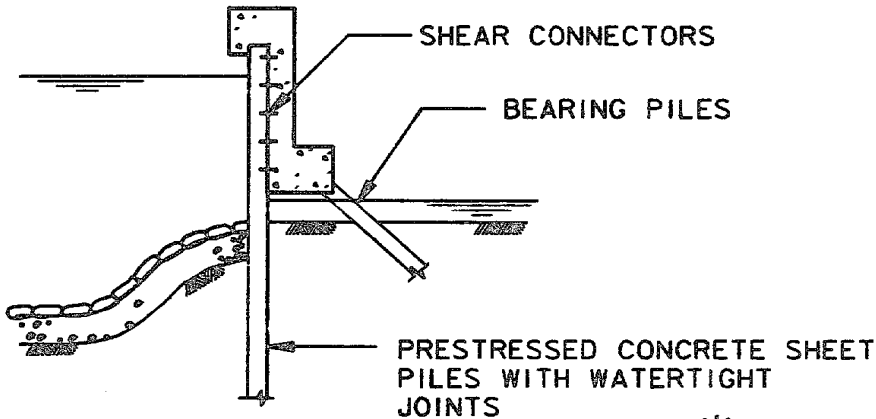

BRACED SHEET PILE COASTAL FLOOD WALL *

* Analysis of this type of walls beyond the scope of this manual.

Figure 2-2. Types of flood walls

29 Sep 89

2-6. Cantilever T-Type Wall. Most flood walls are of the inverted T-type (Figure 2-2). These walls are discussed in detail in Chapter 7. The cross bar of the T serves as a base and the stem serves as the water barrier. When founded on earth, a vertical base key is sometimes used to increase resistance to horizontal movement. If the wall is founded on rock, a key is usually not provided. Where required, the wall can be supported on piles. A sheet pile cutoff can be included to control underseepage or provide scour protection for the foundation. T-type walls may be provided with a horizontal or sloped base. The advantages of sloped and horizontal bases are discussed in paragraph 7-5.

2-7. Cantilever I-Type Wall. I-type flood walls consist of driven sheet piles capped by a concrete wall (Figure 2-2). I-walls are most often used in connection with levee and T-wall junctions or for protection in narrow restricted areas where the wall height is not over 8 to 10 feet, depending on soil properties and geometry. The design of these types of walls is beyond the scope of this manual.

2-8. Other Types of Flood Walls.

a. Braced Sheet Pile Flood Wall. This wall consists of a row of vertical prestressed concrete sheet piles, backed by batter piles connected to the sheet piles by a cast-in-place horizontal concrete beam with shear connectors as required to resist the vertical component of load in the batter pile (Figure 2-2). This type of wall has been used for coastal flood walls. It is ideal for wet areas because no excavation or dewatering is required to construct the wall. The disadvantage is that it is more indeterminate than other wall types. The design of this wall is beyond the scope of this manual.

b. Less Commonly Used Types. There are various other types of walls that may be used for flood walls such as: buttress, counterfort, gravity, cellular, and cellular sheet pile, some of which are shown in Figure 2-3. These walls, except for the gravity wall, are beyond the scope of this manual.

Section III. Differences Between Retaining and Flood Walls

2-9. Purpose of Walls. A retaining wall is any wall that retains material to maintain a change in elevation whereas the principal function of a flood wall is to prevent flooding (inundation) of adjacent land. A floodwall is subject to water force on one side which is usually greater than any resisting earth force on the opposite side. A wall may be a retaining wall for one loading condition and a flood wall for another loading condition. The flood loading (surge tide, river flood, etc.) may be from the same or the opposite direction as the higher earth elevation.

2-10. Seepage and Leakage Control Requirements. All water-retaining structures may be subject to seepage through, under, and around them. Inadequate control of seepage may affect the stability of a flood wall regarding uplift or loss of support resulting from erosion. Properly controlled seepage, even if quantities of flow remain large, presents little or no hazard. Control of

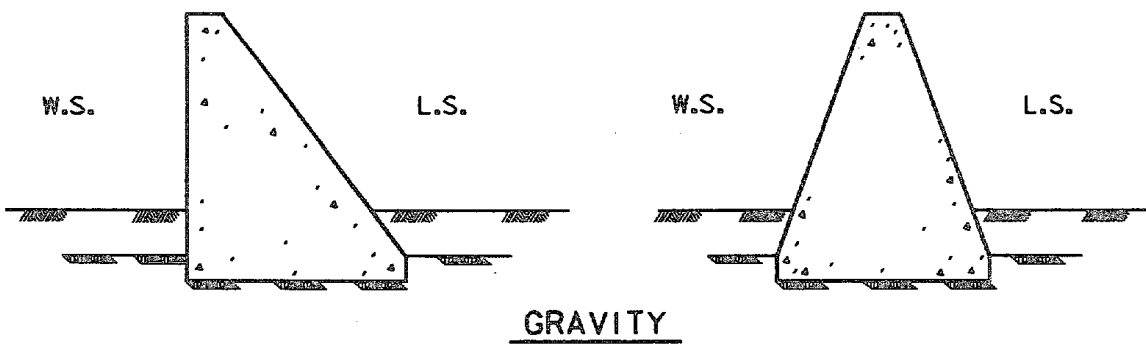
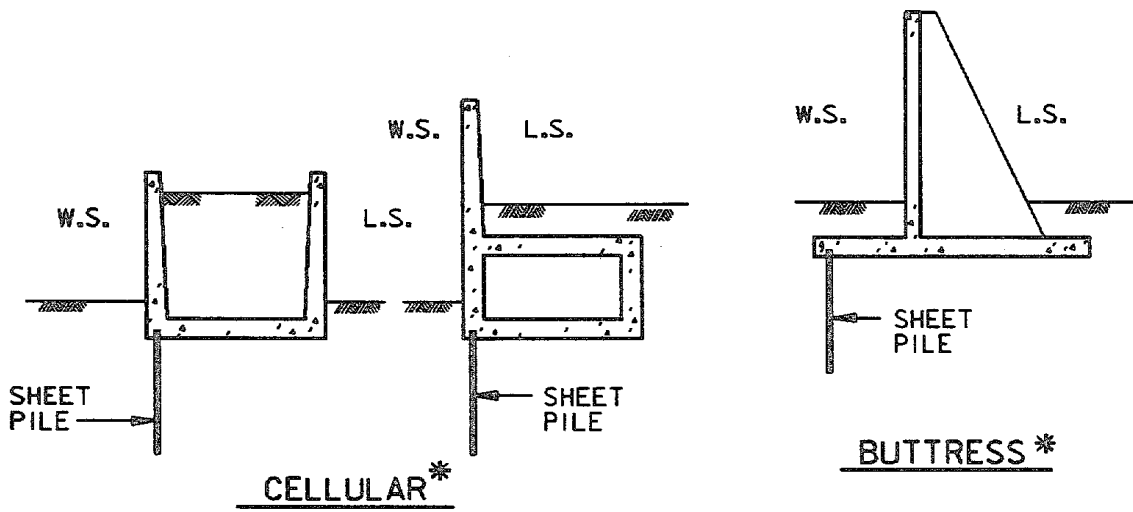
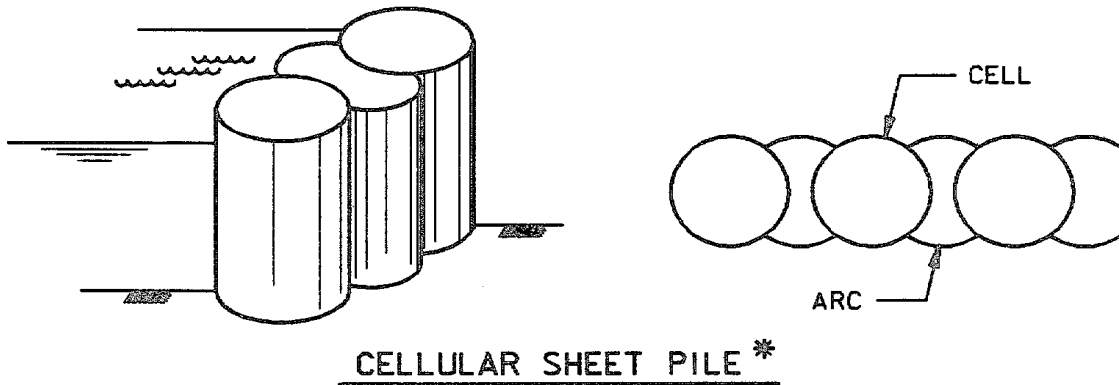

NOTES: W.S.= WATER SIDE (OR SEAWARD, UNPROTECTED SIDE)
L.S.= LAND SIDE (OR PROTECTED SIDE)

* Analysis of this type wall is beyond the scope of this manual.

Figure 2-3. Less commonly used flood wall types

29 Sep 89

through-seepage is provided by water stops. Retaining walls rarely need seepage protection other than to relieve the hydrostatic load on the fill side of the wall. Water stops are used in retaining walls to prevent water passage from the backfill through the vertical joints. Seepage control and water stops are more fully discussed in paragraphs 3-23, 6-4e, 6-6, 7-4, and 7-13.

2-11. Wall Stability. Generally, it is more difficult to design stable flood walls than retaining walls. By their very nature, flood walls are usually built in a flood plain which may have poor foundation conditions. Uplift is always a critical item with flood walls but seldom a problem with retaining walls since the loads acting on a retaining wall are usually soil backfills. The water load on a flood wall can be more severe, especially when wave loadings are applicable. When the ground-water surface is near or above the wall footing, a common occurrence with flood walls, the allowable bearing capacity of the soil is reduced. The reduction of stability, due to the erosion of the earth cover over and beyond the base, must be considered.

2-12. Special Flood Wall Monoliths. Careful attention must be given to wall monoliths that have loading, support, or other conditions that vary along the length of the monolith. These monoliths, which may include closure structures, pipeline crossings, corner structures, etc., must be analyzed as complete three-dimensional entities instead of the usual two-dimensional unit slices.

2-13. Design Philosophy. Retaining walls are normally built as an appurtenance to other structures: dams, hydroelectric power houses, pump stations, etc. The consequences of failure of a retaining wall are often lower than for flood walls. Also, retaining walls are seldom more than a few hundred feet long; if they are designed conservatively, the added costs are of limited significance. Flood walls, on the other hand, are usually the primary feature of a local protection project. They must be designed for the most economical cross section per unit length of wall, because they often extend for great distances. Added to this need for an economical cross section is the requirement for safety. The consequences of failure for a flood wall are normally very great since it protects valuable property and human life. Thus, the design of retaining and flood walls is a complex process involving safety and economy factors, and design must be executed in a logical, conservative manner based on the function of the wall and the consequences of failure. Design documents should describe the decisions leading to the final degree of conservatism.

2-14. Stability Considerations. An adequate assessment of stability must include a rational assessment of loads and must account for the basic structural behavior, the mechanism of transmitting compressive and shearing loads to the foundation, the reaction of the foundation to such loads, and the secondary effects of the foundation behavior on the structure.

Section IV. Coordination Between Disciplines

2-15. Engineering Team. A fully coordinated team of geotechnical and structural engineers, and hydraulic engineers where applicable, should ensure that all pertinent engineering considerations are properly integrated into the

overall design of a structure. Some of the critical aspects of design which require coordination are:

a. Preliminary estimates of geotechnical and hydraulic data, subsurface conditions, and types of structures which are suitable for the foundation.

b. Selection of design parameters, loading conditions, loading effects, potential failure mechanisms, and other related features of the analytical models.

c. Evaluation of the technical and economic feasibility of alternative types of structures.

d. Constructability reviews in accordance with ER 1110-1-803.

e. Refinements of the preliminary structure configuration to reflect the results of detailed site explorations, material availability studies, laboratory testing, and numerical analysis.

f. Modification to the structure configuration during construction due to unexpected variations in the foundation conditions.

Section V. Geotechnical Investigations

2-16. Planning the Investigation.

a. Purpose. The purpose of the geotechnical investigation for wall design is to identify the type and distribution of foundation materials, to identify sources and characteristics of backfill materials, and to determine material parameters for use in design analyses. Specifically, the information obtained will be used to select the foundation type and depth, design the foundation, estimate backfill pressures, locate the ground-water level, estimate settlements, and identify possible excavation problems. For flood walls, foundation underseepage conditions must also be assessed. Detailed information regarding subsurface exploration techniques may be found in EM 1110-1-1804 and EM 1110-2-1907.

b. Review of Existing Information. The first step in an investigational program is to review existing data so that the program can be tailored to confirm and extend the existing knowledge of soil and rock conditions. EM 1110-1-1804 provides a detailed listing of possible data sources; important sources include air photographs, geologic maps, surficial soil maps, and logs from previous borings. In the case of flood walls, study of old topographic maps can provide information on past riverbank or shore geometry and identify likely fill areas.

2-17. Foundation Exploration and Site Characterization.

a. Preliminary Exploration. Where possible, exploration programs should be accomplished in phases, so that information obtained in each phase may be

29 Sep 89

used advantageously in planning later phases. The results of each phase are used to "characterize" the site deposits for analysis and design by developing idealized material profiles and assigning material properties. For long, linear structures like flood walls, geophysical methods such as seismic and resistivity techniques often provide an ability to rapidly define general conditions during the preliminary phase at a modest cost. In alluvial floodplains, air photograph studies can often locate recent channel fillings or other potential problem areas. A moderate number of borings should be obtained at the same time to refine the site characterization and to "calibrate" geophysical findings. Borings should extend deep enough to sample any materials which may affect wall performance; a depth of twice the wall height below the ground surface can be considered a conservative "rule of thumb." For flood walls where underseepage is of concern, a sufficient number of the borings should extend deep enough to establish the thickness of any pervious strata.

b. Detailed Exploration. The purpose of this phase is the development of detailed material profiles and quantification of material parameters. The number of borings should typically be two to five times the number of preliminary borings. No exact spacing is recommended, as the boring layout should consider geologic conditions and the characteristics of the proposed structure. Based on the preliminary site characterization, borings should be situated to confirm the location of significant changes in foundation conditions as well as to confirm the continuity of apparently consistent foundation conditions. At this time, undisturbed samples should be obtained for laboratory testing and/or in situ tests should be performed.

c. Additional Exploration. In some cases, additional exploration phases may be useful to resolve questions arising during detailed design, and/or to provide more detailed information to bidders in the plans and specifications.

2-18. Testing of Foundation Materials.

a. General. Procedures for testing soils are described in EM 1110-2-1906. Procedures for testing rock specimens are described in the Rock Testing Handbook (U. S. Army Engineer Waterways Experiment Station (WES) 1980). Much of the discussion on use of laboratory tests in EM 1110-1-1804 and EM 1110-2-1913 also applies to wall design. For wall design, classification and index tests (water content, Atterberg limits, grain size) should be performed on most or all samples and shear tests should be performed on selected representative undisturbed samples. Where settlement of fine-grained foundation materials is of concern, consolidation tests should also be performed. The strength parameters ϕ and c are not intrinsic material properties but rather are parameters that depend on the applied stresses, the degree of consolidation under those stresses, and the drainage conditions during shear. Consequently, their values must be based on laboratory tests that appropriately model these conditions as expected in the field.

b. Coarse-Grained Materials. Coarse-grained materials such as clean sands and gravels are sufficiently pervious that excess pore pressures do not

29 Sep 89

develop when stress conditions are changed. Their behavior can be modeled for static analyses (earth pressure, sliding, bearing) using parameters from consolidated-drained (S) tests. Failure envelopes plotted in terms of total or effective stresses are the same, and typically exhibit a zero c value and a ϕ value in the range of 25 to 40 degrees. Because of the difficulty of obtaining undisturbed samples of coarse-grained foundation materials, the ϕ value is usually inferred from in situ tests or conservatively assumed based on material type. Where site-specific correlations are desired for important structures, laboratory tests may be performed on samples recompacted to simulate field density.

c. Fine-Grained Materials.

(1) When fine-grained materials such as silts and clays are subjected to stress changes, excess (positive or negative) pore pressures are induced because their low permeability precludes an instantaneous water content change. Undrained (Q or R) tests model such behavior. Shear strength envelopes for undrained tests plotted in terms of total stresses exhibit a non-zero c parameter. However, if plotted in terms of effective stresses, the c parameter is small (zero for all practical purposes) and the friction angle will be essentially equal to that from a drained test. Reasonable estimates of the drained friction angle ϕ' can often be made using correlations with the plasticity index (Figure 2-4).

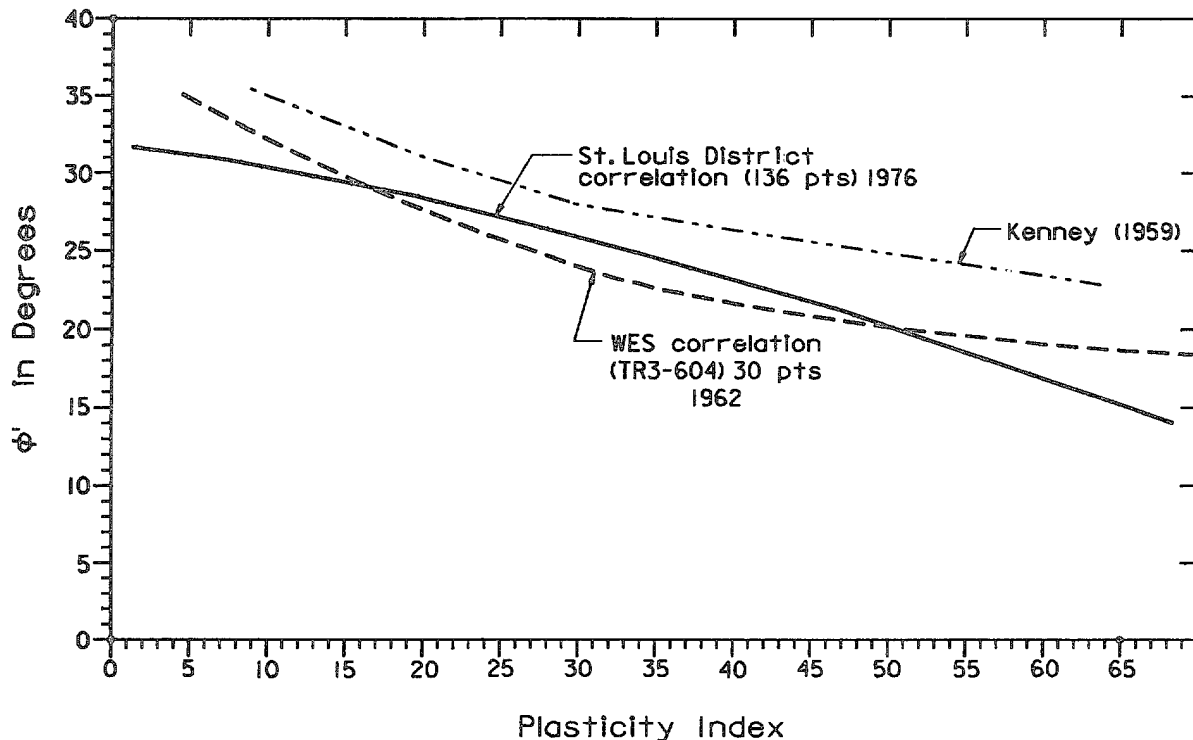

Figure 2-4. Drained friction angle versus plasticity index

29 Sep 89

(2) At low stress levels, such as near the top of a wall, the undrained strength is greater than the drained strength due to the generation of negative pore pressures which can dissipate with time. Such negative pore pressures allow steep temporary cuts to be made in clay soils. Active earth pressures calculated using undrained parameters are minimum (sometimes negative) values that may be unconservative for design. They should be used, however, to calculate crack depths when checking the case of a water-filled crack.

(3) At high stress levels, such as below the base of a high wall, the undrained strength is lower than the drained strength due to generation of positive pore pressures during shear. Consequently, bearing capacity and sliding analyses of walls on fine-grained foundations should be checked using both drained and undrained strengths.

(4) Certain materials such as clay shales exhibit greatly reduced shear strength once shearing has initiated. For walls founded on such materials, sliding analyses should include a check using residual shear strengths.

2-19. In Situ Testing of Foundation Materials.

a. Advantages. For designs involving coarse-grained foundation materials, undisturbed sampling is usually impractical and in situ testing is the only way to obtain an estimate of material properties other than pure assumption. Even where undisturbed samples can be obtained, the use of in situ methods to supplement conventional tests may provide several advantages: lower costs, testing of a greater volume of material, and testing at the in situ stress state. Although numerous types of in situ tests have been devised, those most currently applicable to wall design are the standard penetration test, the cone penetration test, and the pressuremeter test.

b. Standard Penetration Test. The standard penetration test or SPT (ASTM D-1586) is routinely used to estimate the relative density and friction angle of sands using empirical correlations. To minimize effects of overburden stress, the penetration resistance, or N value, is usually corrected to an effective vertical overburden stress of 1 ton per square foot using an equation of the form:

$$N' = C_N N \quad [2-1]$$

where

N' = corrected resistance

C_N = correction factor

N = measured resistance

Table 2-1 and Figure 2-5 summarize the most commonly proposed values for C_N . The drained friction angle ϕ' can be estimated from N' using Figure 2-6. The relative density of normally consolidated sands can be estimated from the correlation obtained by Marcuson and Bieganousky (1977):

$$D_r = 11.7 + 0.76 \left[\left| 222(N) + 1600 - 53(p'_{vo}) - 50(C_u)^2 \right| \right]^{1/2} \quad [2-2]$$

where

p'_{vo} = effective overburden pressure in pounds per square inch

C_u = coefficient of uniformity

Correlations have also been proposed between the SPT and the undrained strength of clays. However, these are generally unreliable and should only be used for very preliminary studies and for checking the reasonableness of SPT and lab data.

c. Cone Penetration Test. The cone penetration test, or CPT (ASTM D 3441-79), is widely used in Europe and is gaining considerable acceptance in the United States. The interpretation of the test is described by Robertson and Campanella (1983). For coarse-grained soils, the cone resistance q_c has been empirically correlated with standard penetration resistance (N value). The ratio (q_c/N) is typically in the range of 2 to 6 and is related to median grain size (see Figure 2-7). The undrained strength of fine-grained soils may be estimated by using a modification of bearing capacity theory:

$$s_u = \frac{q_c - p_o}{N_k} \quad [2-3]$$

where

p_o = the in situ total overburden pressure

N_k = empirical cone factor typically in the range of 10 to 20

The N_k value should be based on local experience and correlation to laboratory tests. Cone penetration tests also may be used to infer soil classification to supplement physical sampling. Figure 2-8 indicates probable soil type as a function of cone resistance and friction ratio. Cone penetration tests may produce erratic results in gravelly soils.

Table 2-1
SPT Correction to 1 tsf (2 ksf)

Effective Overburden Stress (kips/sq ft)	Correction Factor C_N		
	Seed, Arango, and Chan (1975) Seed	Peck and Bazaraa (1969) P & B	Peck, Hanson, and Thornburn (1974) PH & T
0.20	2.25	2.86	
0.40	1.87	2.22	1.54
0.60	1.65	1.82	1.40
0.80	1.50	1.54	1.31
1.00	1.38	1.33	1.23
1.20	1.28	1.18	1.17
1.40	1.19	1.05	1.12
1.60	1.12	0.99	1.08
1.80	1.06	0.96	1.04
2.00	1.00	0.94	1.00
2.20	0.95	0.92	0.97
2.40	0.90	0.90	0.94
2.60	0.86	0.88	0.91
2.80	0.82	0.86	0.89
3.00	0.78	0.84	0.87
3.20	0.74	0.82	0.84
3.40	0.71	0.81	0.82
3.60	0.68	0.79	0.81
3.80	0.65	0.78	0.79
4.00	0.62	0.76	0.77
4.20	0.60	0.75	0.75
4.40	0.57	0.73	0.74
4.60	0.55	0.72	0.72
4.80	0.52	0.71	0.71
5.00	0.50	0.70	0.70

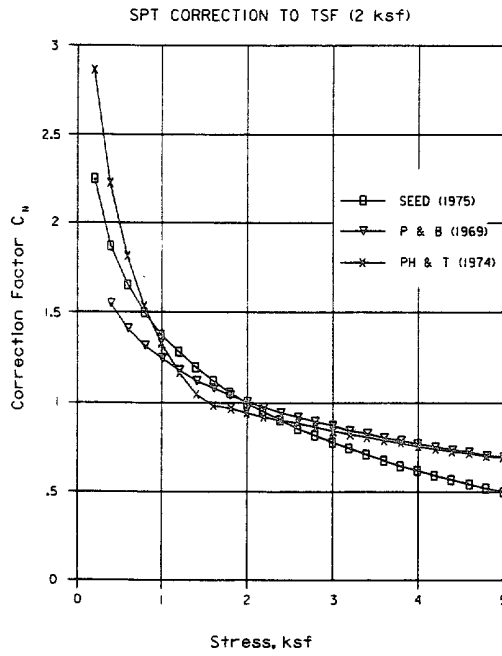

Figure 2-5. SPT correction to 1 tsf (2 ksf)

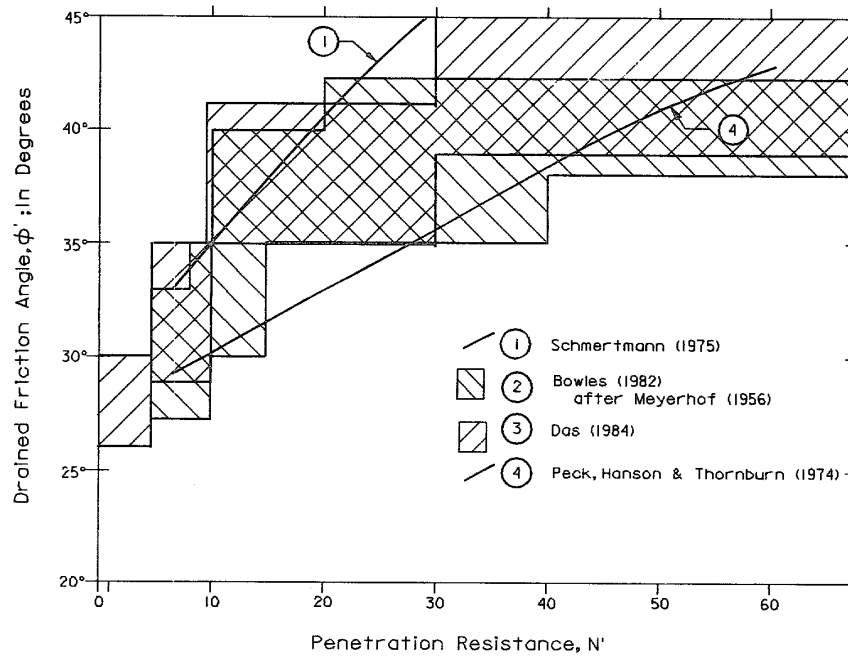

Figure 2-6. ϕ' versus N' for granular materials

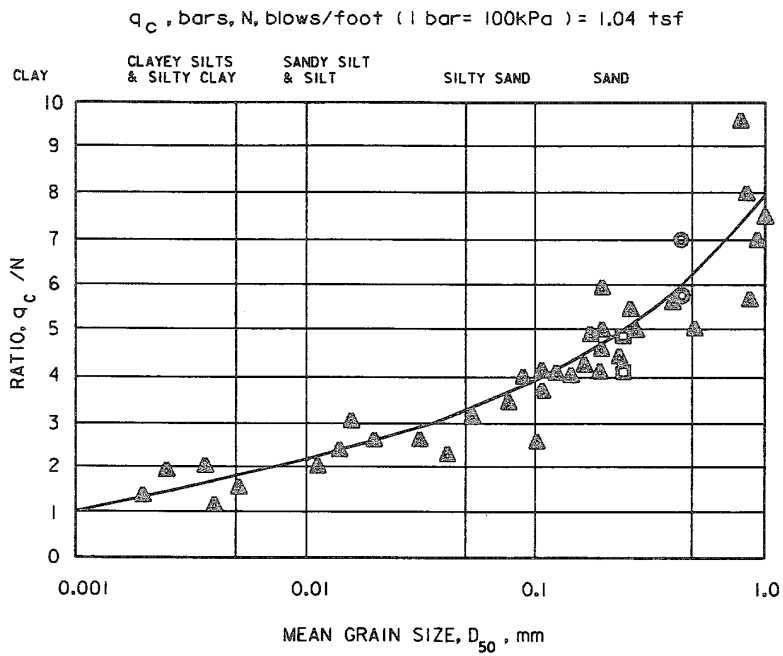

Figure 2-7. q_c/N versus D_{50} (after Robertson and Campanella 1983)

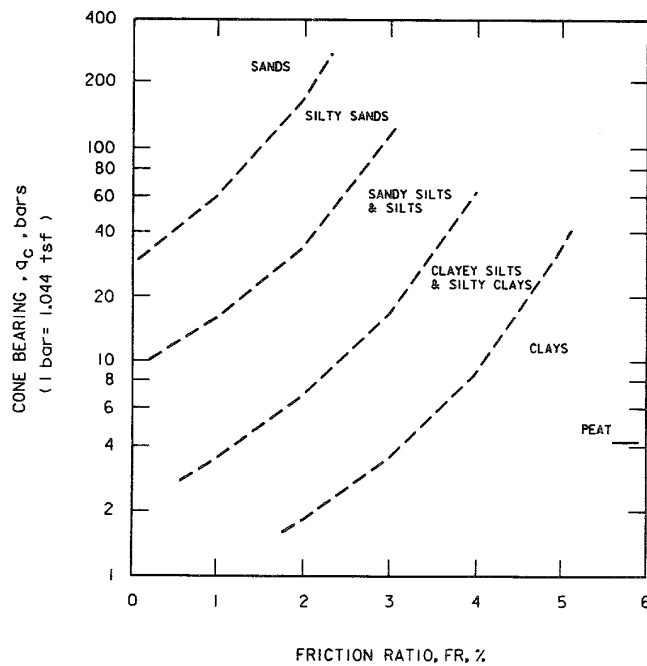

Figure 2-8. Soil classification from cone penetrometer (after Robertson and Campanella 1983)

d. Pressuremeter Test. The pressuremeter test, or PMT, also originated in Europe. Its use and interpretation are discussed by Baguelin, Jezequel, and Shields (1978). Test results are normally used to directly calculate bearing capacity and settlements, but the test can be used to estimate strength parameters. The undrained strength of fine-grained materials is given by:

$$s_u = \frac{p_1 - p'_{ho}}{2K_b} \quad [2-4]$$

where

p_1 = limit pressure

p'_{ho} = effective at-rest horizontal pressure

K_b = a coefficient typically in the range of 2.5 to 3.5 for most clays.

Again, correlation with laboratory tests and local experience is recommended.

2-20. Backfill Materials. Selection of backfill materials is discussed in Chapter 6. Every effort should be made to provide clean, free-draining backfill materials. Density and strength parameters should be determined from tests on laboratory-compacted samples over a range of densities consistent with expected specification requirements. Development of a local data base and correlations for the properties of locally obtained backfill materials may significantly reduce the need for testing. Figure 2-9 provides typical values of the friction angle for use in preliminary designs. The soil type codes are taken from the Unified Soil Classification System, shown in Technical Memorandum 3-357, prepared by the U. S. Army Engineer Waterways Experiment Station in 1960. The data for this figure were assembled from a wide variety of design references.

2-21. Design Strength Selection. As soils are heterogeneous (or random) materials, strength tests invariably exhibit scattered results. The guidance contained in EM 1110-2-1902 regarding the selection of design strengths at or below the thirty-third percentile of the test results is also applicable to walls. For small projects, conservative selection of design strengths near the lower bound of plausible values may be more cost-effective than performing additional tests. Where expected values of drained strengths (ϕ values) are estimated from correlations, tables, and/or experience, a design strength of 90 percent of the expected (most likely) value will usually be sufficiently conservative. In the case of rock foundations, the strength of intact rock, the strength and orientation of discontinuities, and the orientation of joints relative to the possible failure modes must all be considered in selecting design strengths.

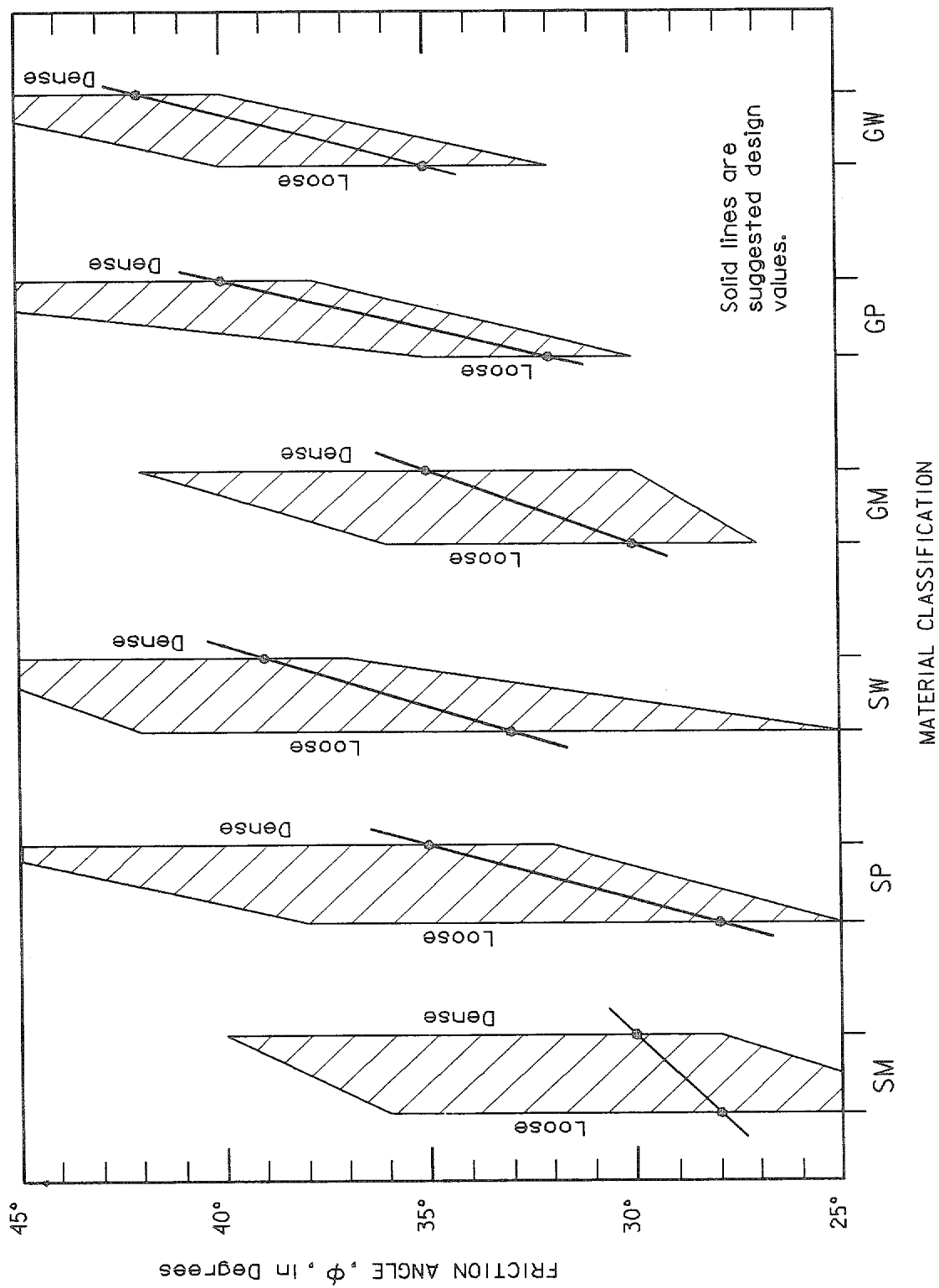

Figure 2-9. Friction angle of granular backfills

CHAPTER 3

FORCES ON WALLS

Section I. Introduction

3-1. General. Retaining walls and flood walls accommodate a difference in soil or water elevation over a typically short horizontal distance. On one side of the wall, the driving side, lateral forces exceed those on the opposite, resisting side; the force difference and resulting moment are accommodated by forces and pressures developed along the base. Lateral forces may be related to gravity, water seepage, waves, wind, and earthquakes. This chapter presents methods for calculating pressures and resulting forces on the driving and resisting sides of walls. These are necessary to calculate the magnitude and location of the base resultant force for overturning and bearing capacity analysis. They are also required for the design of the structural elements of the wall.

3-2. Limit-Equilibrium Analysis. The forces and pressures acting on a wall are in fact highly indeterminate. Static equilibrium equations are insufficient to obtain a solution for lateral forces; additional assumptions must be incorporated in the analysis. For nonlinear materials such as soils, this is commonly and conveniently done by assuming that a "limit" or failure state exists along some surface and that the shear force along the surface corresponds to the shear strength of the material. With these assumptions, equilibrium equations can be solved. Hence, this approach is commonly called "limit-equilibrium analysis." To assure that the assumed failure does not in fact occur, a factor (safety factor or strength mobilization factor) is applied to the material strength. It should be noted that this solution approach differs significantly from that commonly used for indeterminate structural analysis, where stress-strain properties and deformations are employed. This limit-equilibrium approach provides no direct information regarding deformations; it is implied that deformations are sufficient to induce the failure condition. Deformations are indirectly limited to tolerable values by judicious choice of a safety factor.

3-3. Relationship of Forces to Sliding Analysis. Forces calculated in accordance with this chapter are not always equal to those calculated in a sliding analysis (Chapter 4). The methods in this chapter are intended to produce reasonable and somewhat conservative estimates of actual forces operative on the wall. They can be used to perform a quick check on sliding stability as described in paragraph 4-15. The sliding analysis for general cases (paragraph 4-16) considers shear failure along the bases of a collection of interacting free bodies (or wedges) that include both the wall and surrounding soil. Sliding failure is prevented by applying a factor of safety on shear strength equally on all segments of the failure surface. The lateral forces calculated in the sliding analysis are a function of the sliding factor of safety.

Section II. Earth Pressures and Forces

3-4. Cohesionless Materials.

a. Active Earth Pressure. Cohesionless materials such as clean sand are the recommended backfill for retaining walls. Large-scale tests (e.g., Terzaghi 1934; Tschebatarioff 1949; Matsuo, Kenmochi, and Yagi 1978) with cohesionless ($c = 0$) backfills have shown that horizontal pressures are highly dependent on the magnitude and direction of wall movement. The minimum horizontal pressure condition, or active earth pressure, develops when a wall rotates about its base and away from the backfill an amount on the order of 0.001 to 0.003 radian (a top deflection of 0.001 to 0.003h, where h is the wall height). As the wall moves, horizontal stresses in the soil are reduced and vertical stresses due to backfill weight are carried by increasing shear stresses until shear failure is imminent (see Figure 3-1a).

b. Passive Earth Pressure. If a wall is moved toward the backfill, horizontal stresses increase and shear stresses reverse direction, first decreasing and then increasing to a maximum at failure (see Figure 3-1b). Because the horizontal stress component along the shear planes is resisted by both shear stress and vertical stress components, higher horizontal stresses can be developed than for the active pressure case. Development of the maximum possible horizontal stress, or passive pressure, requires much larger wall rotations than for the active case, as much as 0.02 to 0.2 radian. It should be noted that the deformation required to mobilize one-half of the passive pressure is significantly smaller than that required for full mobilization.

c. At-Rest Earth Pressure. If no wall movement occurs, the lateral pressure condition is termed the at-rest pressure.

d. Lateral Earth Pressure Coefficient K. The ratio of the horizontal effective stress to the vertical effective stress in a cohesionless soil mass can be expressed by the earth pressure coefficient K. Typical relationships between the K value and wall movements are shown in Figure 3-2. The value of K can be obtained for active (K_A) and passive (K_P) conditions using limit-equilibrium methods. Empirical equations are available for the at-rest value (K_0) as described in paragraph 3-10.

e. Conditions Affecting Earth Pressure. For complicated backfill conditions, at-rest earth forces can be estimated using the general wedge method combined with factored soil strengths as described in paragraph 3-13. If the mode of wall movement is other than base rotation, the earth pressure and its distribution may differ considerably from any solutions herein and other analysis techniques are required (see paragraph 3-15g). Also, compaction of the backfill behind a wall can produce horizontal pressures in excess of at-rest pressures near the top of a wall as discussed in paragraph 3-17.

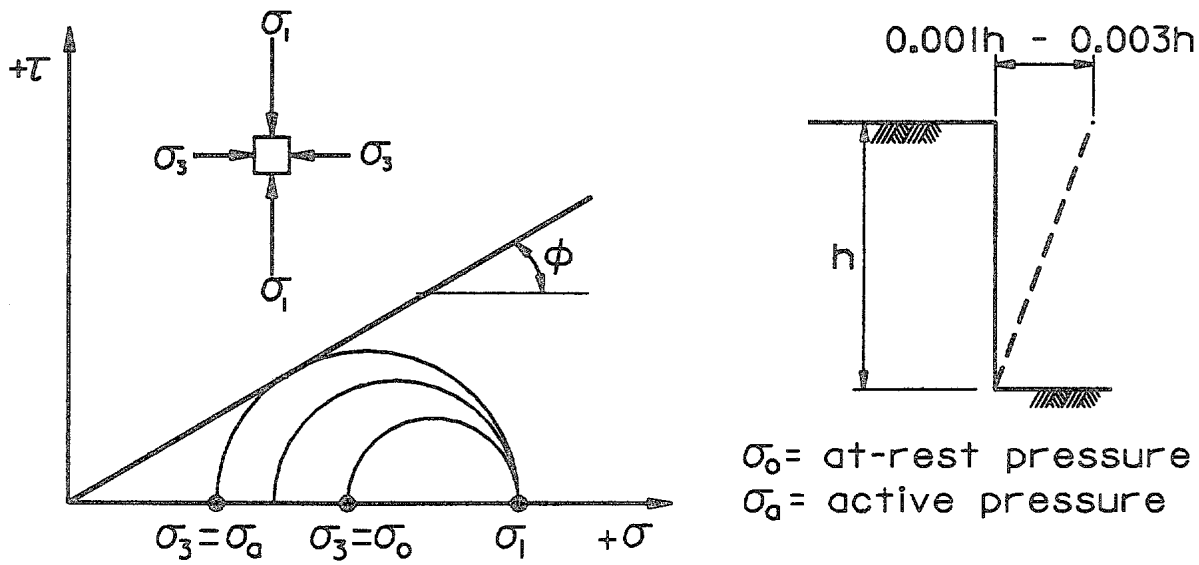

a. Development of active earth pressure

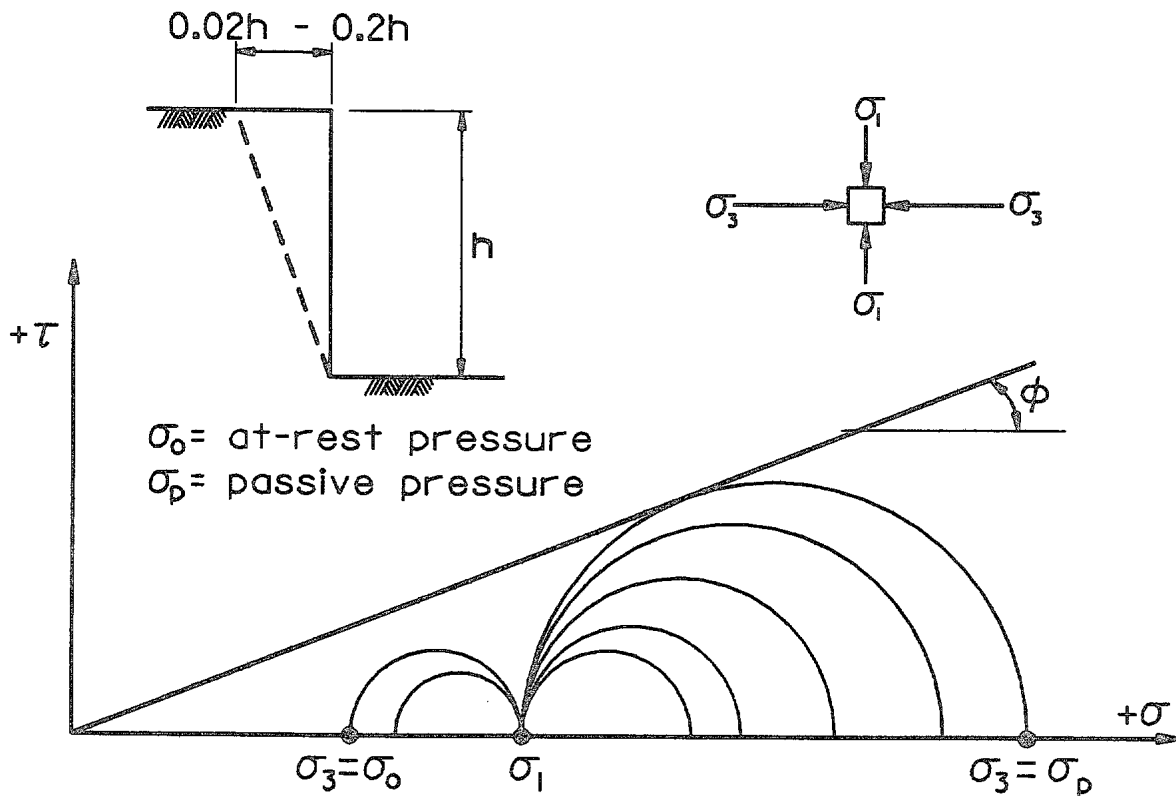

b. Development of passive earth pressure

Figure 3-1. Development of earth pressures for a cohesionless material

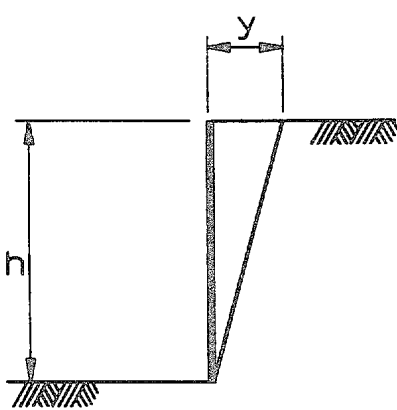
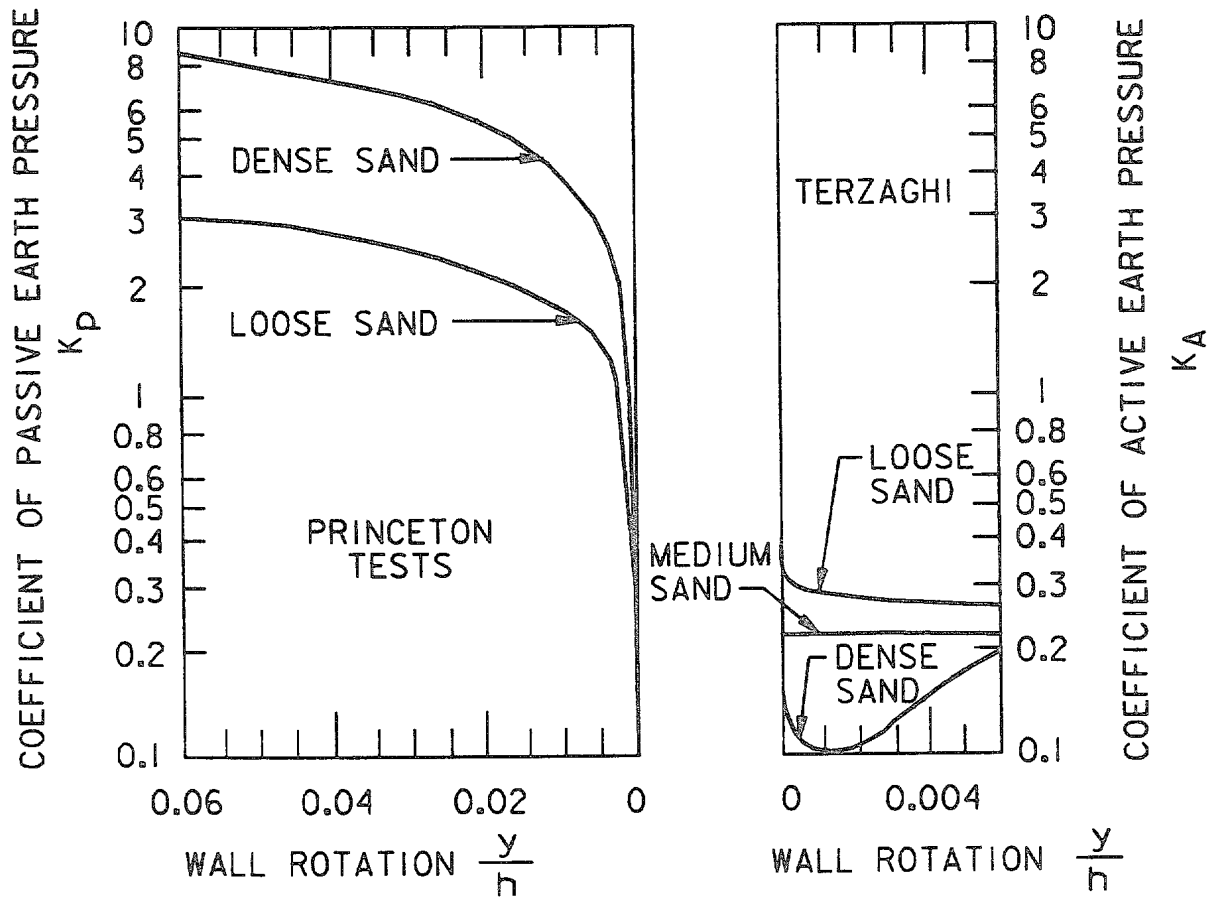

PASSIVE CASE

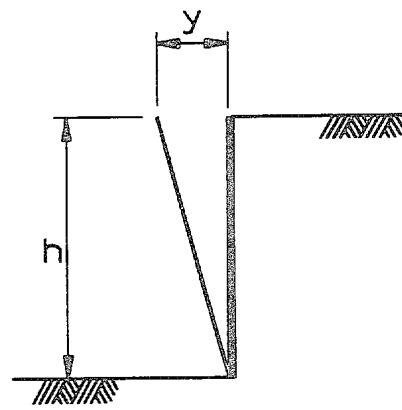

ACTIVE CASE

Figure 3-2. Relationship of earth pressures to wall movements (after Department of the Navy 1982b)

3-5. Cohesive Materials.

a. Strength Properties. So-called cohesive materials, typically fine-grained soils such as clay, exhibit shear strength under zero confining stress when loaded rapidly. The strength at zero confinement is expressed by the parameter c , or cohesion. Cohesive materials are usually saturated or nearly saturated because their small pore diameter attracts capillary water. When stress changes are imposed (such as by wall movement) the soil attempts to change volume. If low permeability prevents volume change from keeping pace with the external stress change, pressure changes are induced in the pore water. What appears to be stress-independent strength (cohesion) is, for the most part, the combined effects of frictional resistance between soil particles and induced pore pressure changes. Pore water tension at low stresses permits vertical cuts in clay; however, such cuts eventually fail as negative pore pressures dissipate and water content increases. Horizontal pressures in cohesive materials are related to the soil's permeability and pore pressure response during shear in addition to wall movement. Therefore they are time dependent.

b. Use as a Backfill Material. It is strongly recommended that cohesionless materials such as clean sands be used for wall backfill materials. Cohesionless materials have more predictable properties than cohesive materials, are less frost susceptible, and provide better drainage. However, there are certain instances (such as walls adjacent to impervious clay cutoffs in flood-control structures) where clay backfills may be unavoidable.

c. Short- and Long-Term Analyses. Solutions are included herein for earth pressures in the terms of the general case involving both the c and ϕ parameters. Where cohesive backfills are used, two analyses (short-term and long-term) are usually required with different sets of strength parameters in order to model conditions that may arise during the life of the wall. Strength tests are further discussed in Chapter 2, Section V.

(1) Short-Term Analyses. These analyses model conditions prevailing before pore pressure dissipation occurs, such as the end-of-construction condition. For these analyses, unconsolidated-undrained (Q) test parameters are appropriate. Often these tests yield a relatively high c value and a low or zero ϕ value. Calculations may indicate that the soil is in tension to significant depths and exerts zero pressure on the wall; thus, the short-term analysis alone will seldom govern wall design. However, the zone of theoretically negative soil pressure may correspond to cracking and should be assumed to crack as described in paragraphs 3-15f and 4-18. Water entering these cracks may exert significant horizontal pressure on a wall. Therefore, short-term stability analyses should include a check of the effect of water pressure in tension cracks.

(2) Long-Term Analyses. These analyses model conditions prevailing after shear-induced excess pore pressures have dissipated. (Dissipation herein includes negative pore pressures increasing to zero.) For long-term analysis, consolidated-drained (S) test parameters are appropriate. These

29 Sep 89

tests usually yield a relatively high ϕ value and a relatively low or zero c value.

d. Overconsolidated "Swelling" Clay Soils. For highly overconsolidated and/or "swelling" clay soils, lateral pressures may be developed in excess of those calculated using drained or undrained strength parameters. These pressures cannot generally be determined using limit-equilibrium techniques (see, e.g., Brooker and Ireland 1965). The use of such soils around retaining walls should be avoided.

3-6. Pressures in Soil-Water Systems. Soil grains are able to transmit shear stresses; water cannot. Consequently, effective pressures in soil may differ on horizontal and vertical planes but water pressures cannot. Effective soil pressures are therefore separated from water pressures in calculations. If the value of K is established, horizontal effective stresses may be calculated by multiplying the effective vertical stress at any point by the corresponding K value (see Figure 3-3). To obtain the total horizontal pressure, the effective horizontal pressure is added to the water pressure. Where more than one soil layer is present, vertical pressures increase continuously with depth but the horizontal pressure diagrams may be discontinuous as shown. Combining water pressures with effective earth pressures is further discussed in paragraphs 3-15 and 3-18.

3-7. Design Earth Pressures and Forces, Driving Side.

a. Use of At-Rest Earth Pressures. The driving side of a retaining wall or flood wall is defined as that side on which soil and/or water exerts a horizontal force tending to cause instability. Designers have often assumed active earth pressure on the driving side because movements required to develop active pressures are small. However, several reasons exist to design walls for at-rest pressures. Because designs incorporate factors of safety, walls may be quite rigid and pressures may be greater than active. Hydraulic structures in particular are designed using conservative criteria that result in relatively stiff wall designs. Walls founded on rock or stiff soil foundations may not yield sufficiently to develop active earth pressures. Even for foundations capable of yielding, certain experiments with granular backfill (Matsuo, Kenmochi, and Yagi 1978) indicate that, following initial yield and development of active pressures, horizontal pressures may in time return to at-rest values. Another reference (Casagrande 1973) states that the gradual buildup of the backfill in compacted lifts produces greater-than-active pressures as do long-term effects from vibrations, water level fluctuations, and temperature changes.

b. Estimation of Operative Pressures. Design analyses require an estimate of the expected "operative" (nonfailure) pressures on the wall for overturning and bearing capacity analyses and structural design. Therefore, walls should be designed to be safe against overturning and bearing failure for at-rest earth pressure conditions, and structural elements should be designed assuming at-rest earth pressures on the driving side. The lateral soil forces calculated using the multiple wedge sliding analysis described in Chapter 4

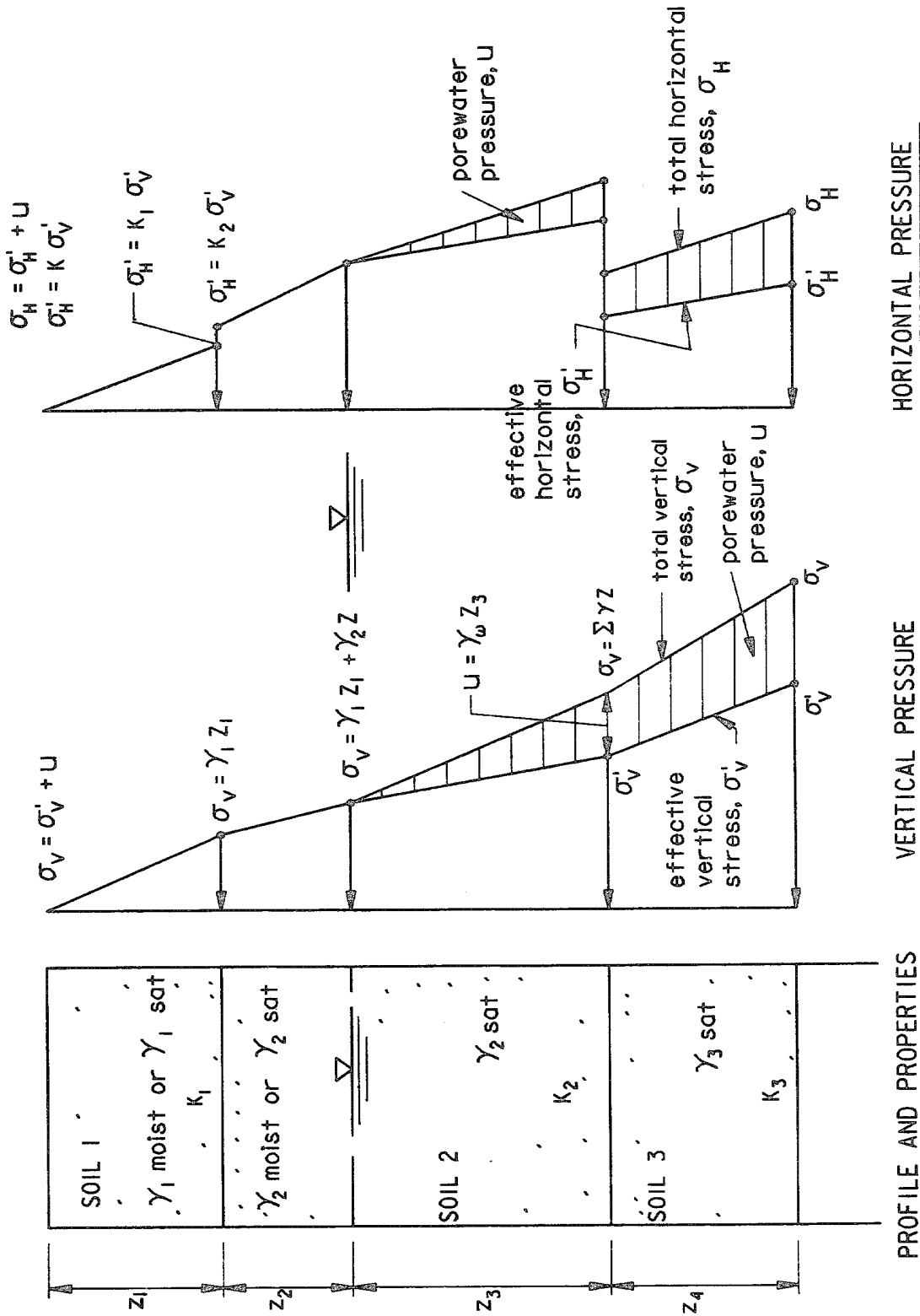

Figure 3-3. Vertical and horizontal pressures in a cohesionless soil mass

are in the at-rest pressure range when a safety factor of 1.5 is obtained.

c. Compaction and Surcharge Effects. Where significant compaction effort is specified for the backfill, design earth pressures should be increased beyond the at-rest values for depths above a "critical" depth as described in paragraph 3-17. Where surcharges are expected above the backfill (in stockpiles, rails, footings, etc.), the additional horizontal earth pressure due to the surcharge should be determined as discussed in paragraph 3-16 and superimposed on the at-rest pressure diagram. Examples of these effects are given in Appendix M.

3-8. Design Earth Pressures and Forces, Resisting Side.

a. Background. The resisting side of a wall is defined as that side where soil and/or water provide a lateral reaction tending to resist instability. The maximum earth force that can be developed is the passive earth force. However, for a wall in equilibrium, the actual resisting-side force will typically be smaller than the passive force as the forces on the driving side, base, and resisting side taken together must satisfy static equilibrium. The resistances to the driving-side force provided by the resisting-side force and the base shear force, respectively, are indeterminate. Allocation of the total resistance between these two forces is judgmental.

b. Estimation of Passive Resistance. A conservative and convenient design approach is to assume the resisting-side force is zero for overturning and bearing capacity analyses and for structural design. However, in some cases, such as walls with relatively deep foundations, it may be desirable to consider some lateral resistance for these analyses. To justifiably assume a non-zero resisting-side force, the material must not lose its resistance characteristics with any probable change in water content or environmental conditions and must not be eroded or excavated during the life of the wall. If such assumptions can be justified, at-rest conditions may be conservatively assumed on the resisting side. Resisting-side pressures and forces generally should not be assumed to exceed at-rest conditions when calculating the base resultant force and location and when designing structural components. However, if the driving-side earth force exceeds the sum of the resisting side at-rest earth force (if present) and the maximum available base shear force calculated using unfactored shear parameters, the additional required resistance should be assumed to be provided by additional resisting-side pressure. In no case should the resisting-side earth pressure exceed one-half the passive pressure calculated using unfactored shear strengths for overturning and bearing capacity analyses and structural design.

c. Horizontal Force Allocation. To summarize, the horizontal force allocation for overturning analysis, bearing capacity analysis, and design of structural components should be computed as follows:

(1) Calculate the at-rest effective earth force on the driving side (paragraphs 3-10 through 3-13). Superimpose surcharge effects if present (paragraph 3-16). Add water pressures, if present.

(2) Assume that the resisting-side earth force equals zero or calculate and apply the at-rest earth force on the resisting side of the wall, if justified (paragraphs 3-10 through 3-13). Add water forces if present.

(3) Assume that the horizontal component of the base resultant is equal to the difference between the horizontal forces from (1) and (2).

(4) If the maximum available base shear force is exceeded, assume that the remaining horizontal force is resisted by mobilizing a greater fraction of passive pressure so long as not more than one-half the available passive force is used. (This may occur where the resisting-side soil is strong relative to the driving-side and base soils.)

d. Sliding Stability Check. Sliding stability should be checked using the single or multiple wedge methods found in paragraphs 4-15 and 4-16, respectively.

3-9. Design Earth Pressures and Forces on the Base.

a. Calculation of Resultant Force on Base. The resultant force on the base, its direction, and its location must be such that the wall is in static equilibrium for the "operative" loads (see Figure 3-4). In Figure 3-4a, the vertical component of the resultant is equal and opposite the summed weights of the "structural wedge" and the horizontal component is equal to the difference of the driving-side and resisting-side forces. Figure 3-4b illustrates a more complicated example including water and a sloping base with a key. The vertical and horizontal components of the base uplift force are calculated from base water pressures obtained from a seepage analysis. The remaining vertical and horizontal forces required for equilibrium are provided by components of the base shear force T and effective normal force N' . An overturning analysis as described in Chapter 4 must be performed in order to determine the effective normal force N' and its location.

b. Computation of Base Pressures. The effective earth pressure on the base is assumed to vary linearly and N' is applied at the centroid of the pressure diagram. When the resultant falls within the middle one-third of the base, the effective base pressures q' are calculated by the following equation:

$$q' = \left(\frac{N'}{B}\right)\left(1 \pm \frac{6e}{B}\right) \quad [3-1]$$

where

N' = effective normal force on base of structure

B = width of base of structure

e = eccentricity of N' from center of base

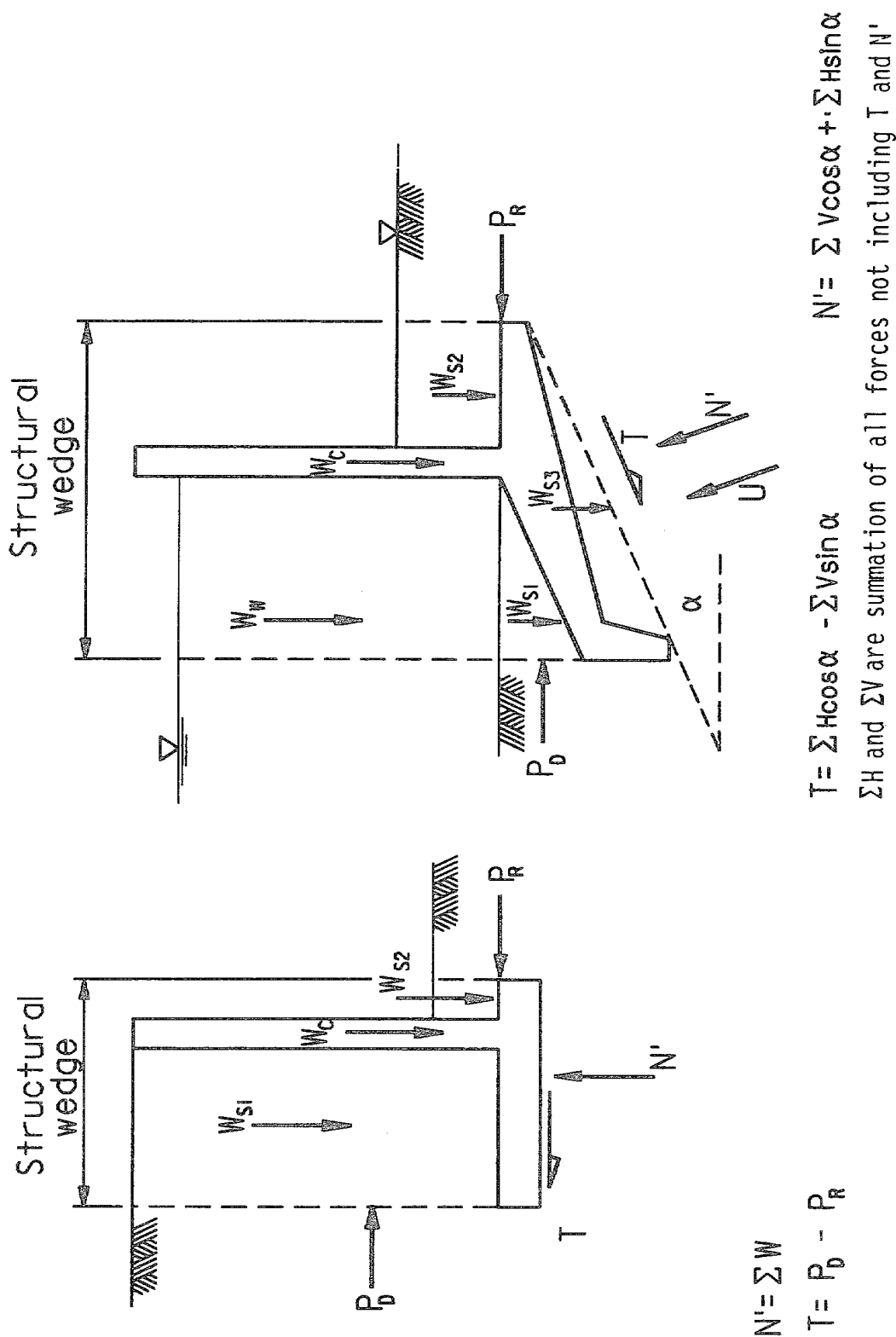

a. Simple retaining wall

b. Flood wall with sloping base and key

Figure 3-4. Forces on base of wall

This is shown in Figure 3-5, a and b. If the resultant falls outside the middle one-third of the base, i.e., e is greater than $B/6$, as shown in Figure 3-5c, the pressure distribution is triangular with a maximum pressure equal to

$$q'_{\max} = \frac{4}{3} \left(\frac{N'}{B - 2e} \right) \quad [3-2]$$

The base will be in compression over a distance b from the toe computed as

$$b = \frac{3}{2} (B - 2e) \quad [3-3]$$

Refer to Appendix N for example computations.

3-10. At-Rest Earth Pressure Equations.

a. Horizontal Backfill. For the special case of a horizontal backfill surface and a normally consolidated backfill (no compaction or other prestress effects) the at-rest pressure coefficient K_o can be estimated from Jaky's (1944) equation

$$K_o = 1 - \sin \phi' \quad [3-4]$$

and the lateral earth pressure computed by

$$P_o = \gamma' K_o z$$

where

ϕ' = drained internal friction angle

γ' = effective unit weight (moist or saturated above water table, submerged or buoyant below water table)

z = depth below surface of backfill along a vertical plane

b. Sloping Backfills. For normally consolidated sloping backfills, results of experiments to measure K_o are quite variable. The following equation proposed by the Danish Code (Danish Geotechnical Institute 1978) is recommended:

$$K_{o\beta} = K_o (1 + \sin \beta) \quad [3-5]$$

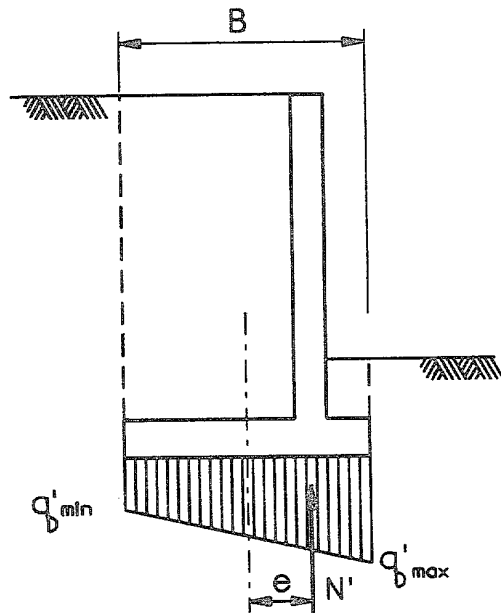

$$q'_b = \frac{N'}{A} \pm \frac{Mc}{I}$$

$$q'_{b\max} = \left(\frac{N'}{B}\right)\left(1 + \frac{6e}{B}\right)$$

$$q'_{b\min} = \left(\frac{N'}{B}\right)\left(1 - \frac{6e}{B}\right)$$

a. Simple wall, resultant in middle one-third of base

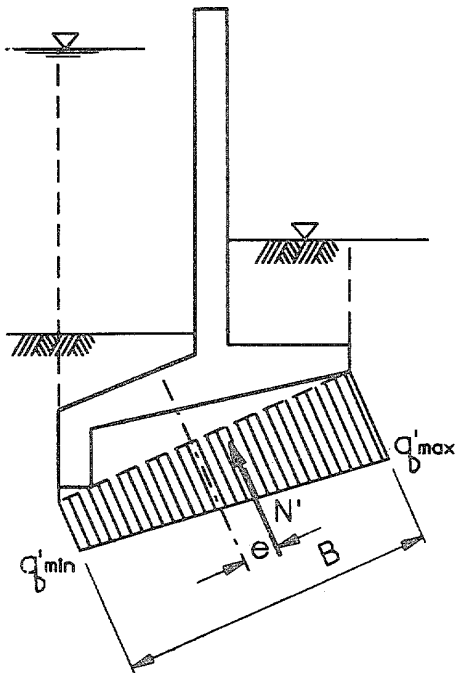

b. Flood wall with sloping base

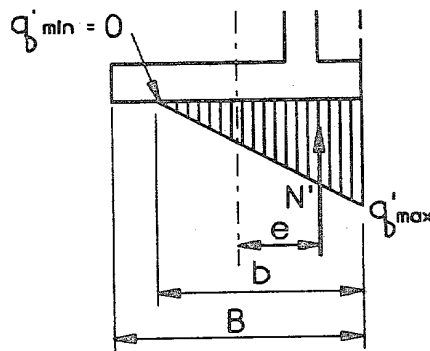

$$q'_{b\max} = \left(\frac{4}{3}\right)\left(\frac{N'}{B - 2e}\right)$$

$$b = \left(\frac{3}{2}\right)(B - 2e)$$

c. Pressure for resultant outside middle one-third

Figure 3-5. Base pressures

Substituting Equation 3-4 in 3-5 gives:

$$K_{o\beta} = (1 - \sin \phi') (1 + \sin \beta) \quad [3-6]$$

and the lateral earth pressure computed by

$$P_o = \gamma' K_{o\beta} z$$

where β is the slope angle from the horizontal. β is positive for a soil layer that slopes upward and away from the structure. Values for K_o and $K_{o\beta}$ are given in Appendix E.

c. General Conditions. For walls with irregular backfill surfaces, non-homogeneous backfills, surcharge loadings, and/or other complicating conditions, empirical relationships for the at-rest pressure are not generally available. For routine designs, an approximate solution for the horizontal earth force may be obtained using Coulomb's active force equation or the general wedge method with values of c and $\tan \phi$ multiplied by a strength mobilization factor (defined in paragraph 3-11). Because this is an empirical approach, results will differ slightly from calculations using Equations 3-4 through 3-6 where companion solutions can be obtained. Appendix E includes a comparison of K_o values so obtained for both horizontal and sloping backfills. Figure 3-6 shows a comparison of Jaky's equation with Coulomb's equation for a horizontal backfill.

d. Resisting Side. Jaky's equation and the Danish Code equation may be used to compute at-rest pressures for the resisting side for horizontal and sloping soil surfaces, respectively. Example computations are shown in example 7 of Appendix M and in Appendix N.

3-11. Strength Mobilization Factor.

a. Definition. The strength mobilization factor (SMF) is defined as the ratio of the assumed mobilized or developed shear stress τ along an assumed slip surface to the maximum shear strength τ_f of the soil material at failure. If an appropriate SMF value is assumed and applied to c and $\tan \phi$, it allows calculation of greater-than-active earth pressures using Coulomb's active force equation (paragraph 3-12) or the general wedge equation (paragraph 3-13). Alternatively, the safety against sliding may be assessed by calculating the average SMF along an assumed sliding surface from an equilibrium analysis and comparing it to a recommended maximum value. These concepts are illustrated in Figure 3-7. In equation form, the strength mobilization factor may be expressed as:

$$SMF = \frac{\tau}{\tau_f} \quad [3-7]$$

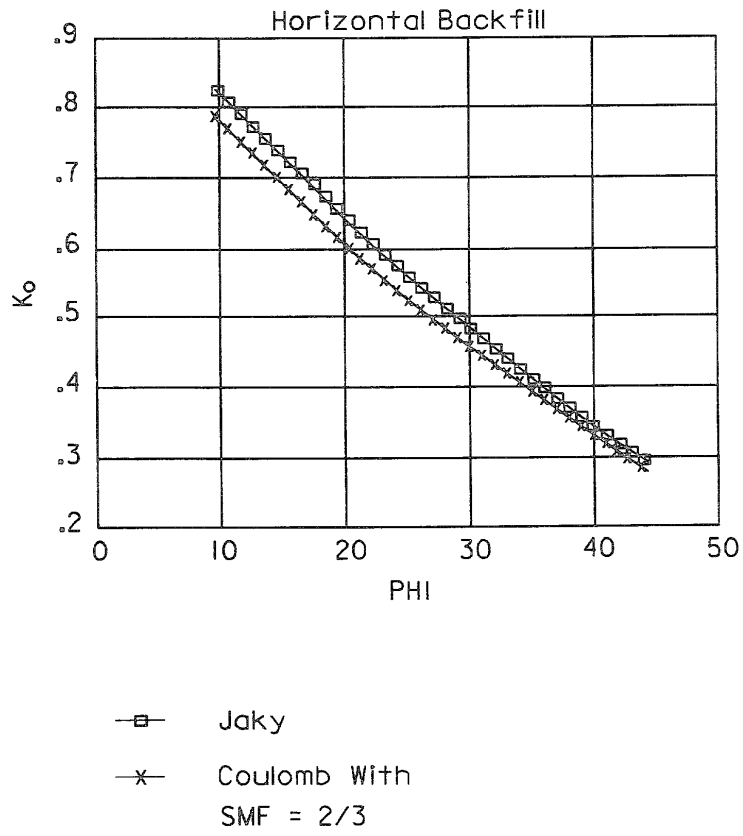
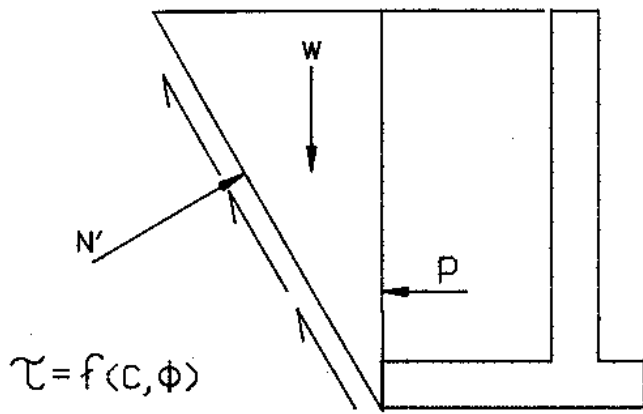
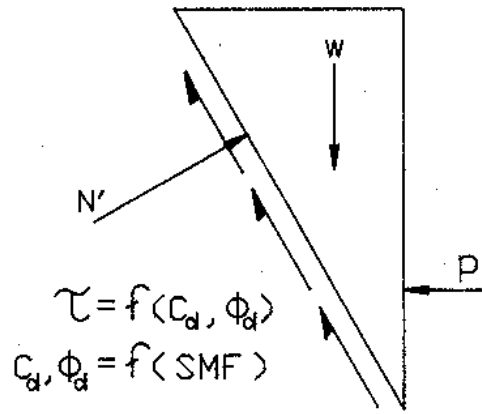

Figure 3-6. At-rest earth pressure coefficients



Solve for P

ACTIVE EARTH FORCE



Assume $SMF = 2/3$

Solve for P

AT-REST EARTH FORCE

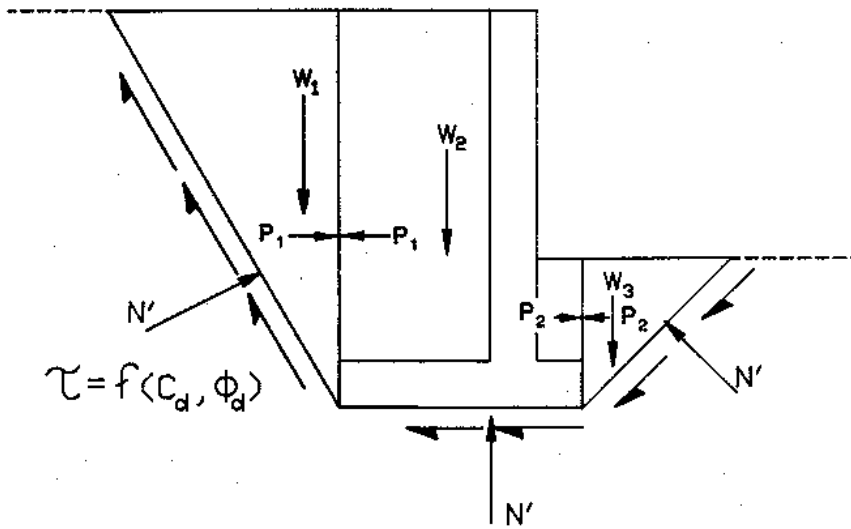

Assume global equilibrium

Solve for SMF

SLIDING

Figure 3-7. Application of the strength mobilization factor

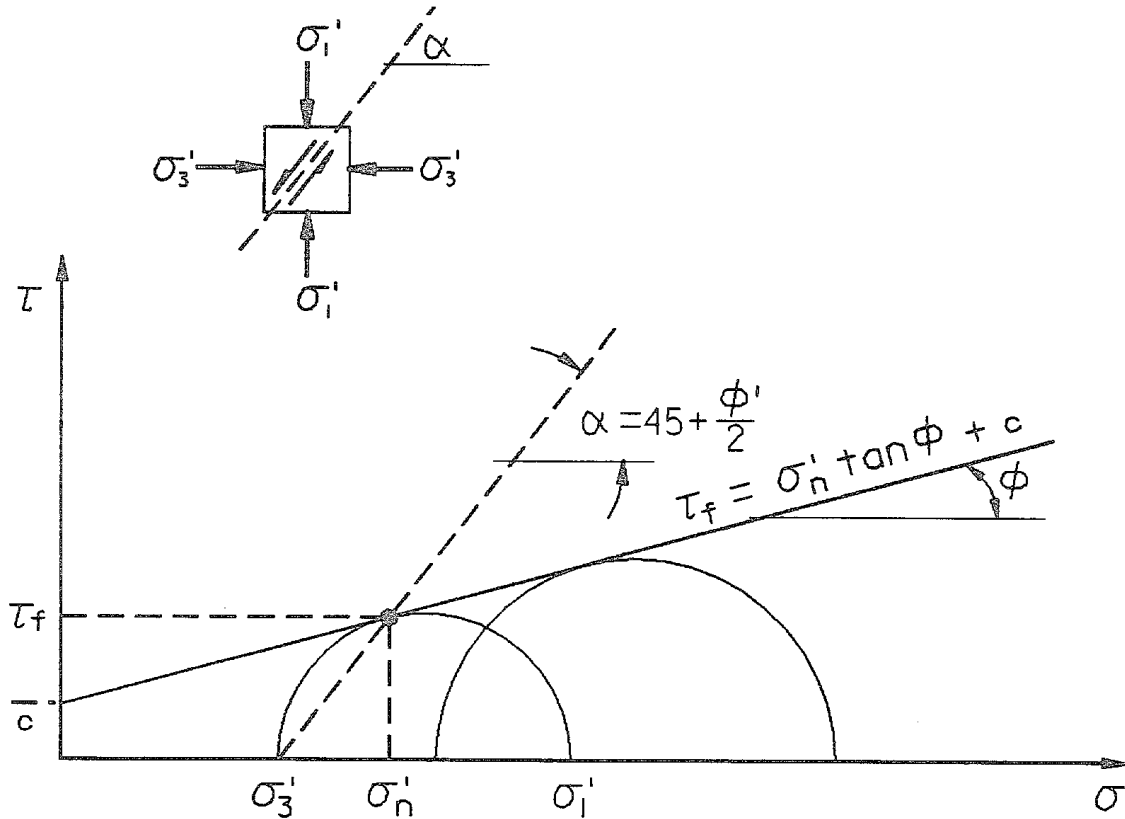

Figure 3-8. Mohr-Coulomb failure criterion

b. Developed Shear Stress. According to the Mohr-Coulomb failure criterion (Figure 3-8) the shear strength on the failure plane is defined as

$$\tau_f = \sigma_n' \tan \phi + c \quad [3-8]$$

where

σ_n' = effective normal stress

ϕ, c = shear strength parameters of soil (where ϕ and c in the above equation are drained strengths ($\phi = \phi'$, $c = c'$) for long-term analysis and undrained ($\phi = 0$, $c = S_u$) for short-term analysis of cohesive materials).

The failure plane is inclined $45 + \phi/2$ degrees from the plane of the major principal stress. For limit-equilibrium analyses to be valid, the assumed slip surface must be inclined at this angle relative to the principal stresses. In the Coulomb and general wedge methods, a plane slip surface is assumed. Discontinuities in the backfill surface, surcharges, and wall friction all cause variation in the principal stress directions and induce

curvature in the slip surface. Assuming that the plane slip surface approximation is valid and is properly oriented relative to the principal stresses, the shear stress on it is:

$$\tau = \text{SMF} (c) + \sigma'_n \text{SMF} (\tan \phi) \quad [3-9]$$

Thus, the shear stress on a presumed slip surface is taken to be a function of the shear strength parameters, the effective normal stress, and the strength mobilization factor.

c. Developed Shear Strength Parameters. Multiplying the shear strength parameters (c and $\tan \phi$) by the appropriate SMF reduces them to the "developed" values (c_d and $\tan \phi_d$) assumed to be operative in equilibrium conditions. The developed shear strength parameters, the actual shear strength parameters, and the SMF are related as follows:

$$\text{SMF} = \frac{\tan \phi_d}{\tan \phi} = \frac{c_d}{c} \quad [3-10]$$

To estimate at-rest pressures for design using Coulomb's active earth pressure equation or the general wedge equation, the SMF should be taken as 2/3 (0.667). K_o values so obtained are compared with Jaky's equation in Figure 3-6. The Coulomb equation with an SMF of 2/3 is compared to the Danish Code and Jaky equations in Appendix E. It should be noted that as the ratio, $\tan \beta / \tan \phi$, exceeds 0.56, the lateral earth force computed by the Coulomb or general wedge equations using an SMF = 2/3 will be increasingly larger than that given by computing the earth force using a K_o given by the Danish Code equation, for those conditions where the Danish Code equation applies. Therefore, computing at-rest earth loadings using the Coulomb or general wedge equations for a sloping backfill when $\tan \beta / \tan \phi$ exceeds 0.56 will be conservative (see Appendix E).

3-12. Earth Force Calculation, Coulomb's Equations.

a. General.

(1) Coulomb's equations solve for active and passive earth forces by analyzing the equilibrium of a wedge-shaped soil mass. The mass is assumed to be a rigid body sliding along a plane slip surface. Design (at-rest) earth pressures and forces may be estimated using developed shear strength parameters (Equation 3-10) corresponding to an SMF of 2/3 in the Coulomb active earth force equation. The Coulomb equations have the advantage of providing a direct solution where the following conditions hold:

(a) There is only one soil material (material properties are constant). There can be more than one soil layer if all the soil layers are horizontal.

(b) The backfill surface is planar (it may be inclined).

(c) The backfill is completely above or completely below the water table, unless the top surface is horizontal, in which case the water table may be anywhere within the backfill.

(d) Any surcharge is uniform and covers the entire surface of the driving wedge.

(e) The backfill is cohesionless, unless the top surface is horizontal, in which case the backfill may be either cohesionless or cohesive.

(2) Although Coulomb's equation solves only for forces, it is commonly expressed as the product of a constant horizontal pressure coefficient K and the area under a vertical effective stress diagram. Assuming the concept of a constant K is valid, horizontal earth pressures can be calculated as the product of K times the effective vertical stress. The variation of the Coulomb solution from a more rigorous log-spiral solution is generally less than 10 percent, as shown in Figure 3-9.

b. Driving-Side Earth Force.

(1) The total active force P_A on a unit length of wall backfilled with a cohesionless material ($c = 0$) is given by:

$$P_A = \frac{1}{2} \gamma' \frac{1}{\sin \theta \cos \delta} K_A h^2 \quad [3-11]$$

and acts at an angle δ from a line normal to the wall. In the above equation (refer to Figure 3-10):

γ' = effective unit weight (moist or unsaturated unit weight if above the water table, submerged or buoyant unit weight if below the water table)

θ = angle of the wall face from horizontal (90 degrees for walls with a vertical back face or structural wedge)

δ = angle of wall friction

K_A = active earth pressure coefficient

h = height of fill against gravity wall or height of fill at a vertical plane on which the force is being computed

where

$$K_A = \frac{\sin^2 (\theta + \phi) \cos \delta}{\sin \theta \sin (\theta - \delta) \left[1 + \sqrt{\frac{\sin (\phi + \delta) \sin (\phi - \beta)}{\sin (\theta - \delta) \sin (\theta + \beta)}} \right]^2} \quad [3-12]$$

Examples 1 and 2 in Appendix M and the examples in Appendix N demonstrate the use of Equation 3-12.

(2) When wall friction is neglected ($\delta = 0$), Equation 3-12 reduces to:

$$K_A = \frac{\sin^2 (\theta + \phi)}{\sin^2 \theta \left[1 + \sqrt{\frac{\sin \phi \sin (\phi - \beta)}{\sin \theta \sin (\theta + \beta)}} \right]^2} \quad [3-13]$$

(3) For the case of is no wall friction ($\delta = 0$) and a vertical wall ($\theta = 90$ degrees),

$$K_A = \frac{\cos^2 \phi}{\left[1 + \sqrt{\frac{\sin \phi \sin (\phi - \beta)}{\cos \beta}} \right]^2} \quad [3-14]$$

(4) For the special case of no wall friction, horizontal backfill surface, and a vertical wall, Coulomb's equation for K_A reduces to:

$$K_A = \frac{1 - \sin \phi}{1 + \sin \phi} = \tan^2 \left(45^\circ - \frac{\phi}{2} \right) \quad [3-15]$$

which is identical to Rankine's equation for this special case.

(5) As stated in paragraph 3-11c and demonstrated in Figure 3-6 and Appendix E, a developed ϕ angle computed by Equation 3-10 using an SMF of 2/3 can be used in Coulomb's equation to compute an earth pressure coefficient close to that given by the Jaky or Danish Code equations.

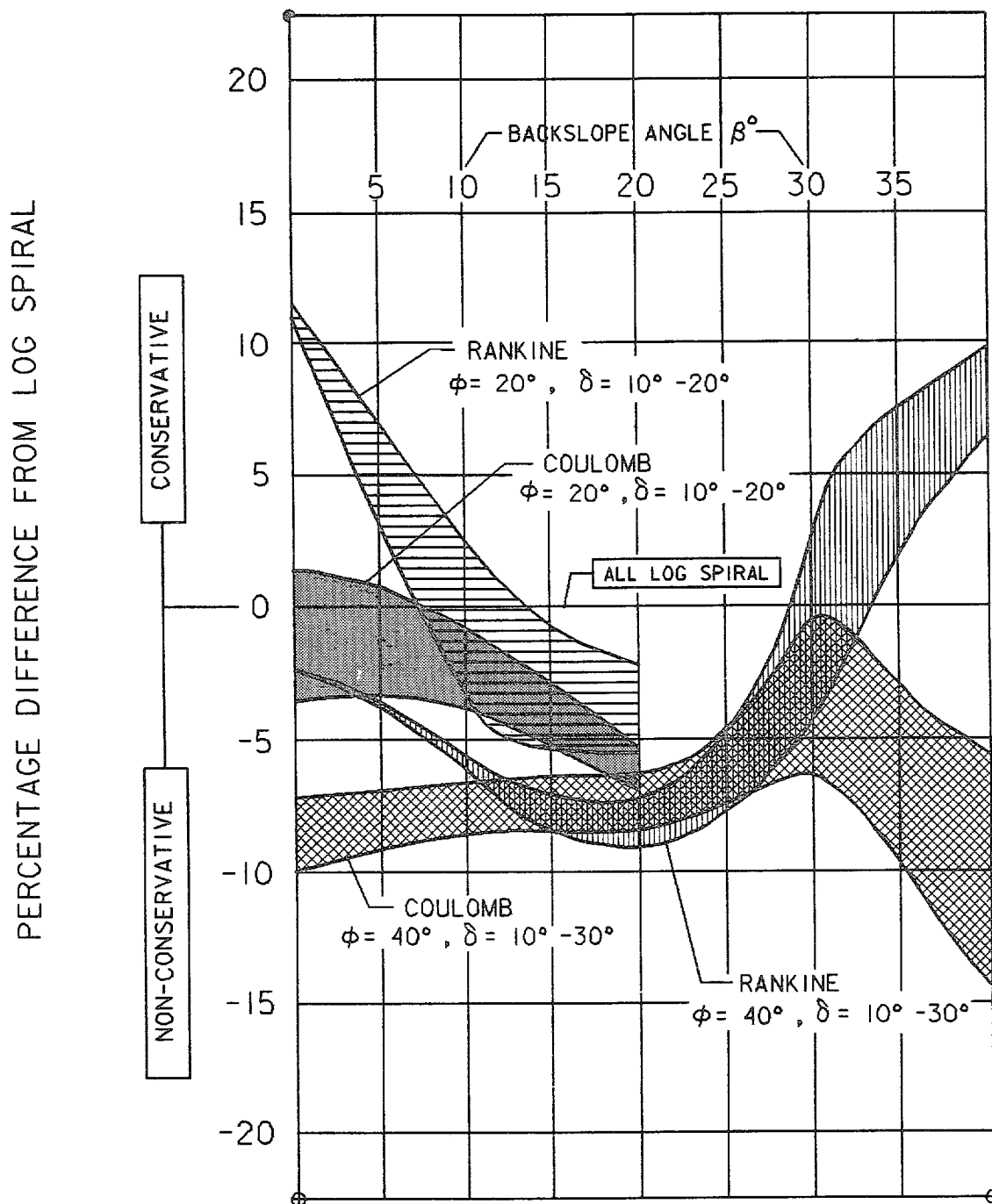

NOTE: Log spiral calculations based upon Caquot and Kerisel coefficients. Range of values for Rankine is from influence of wall friction on log spiral.

Figure 3-9. Comparison of active earth pressures (after Driscoll 1979)

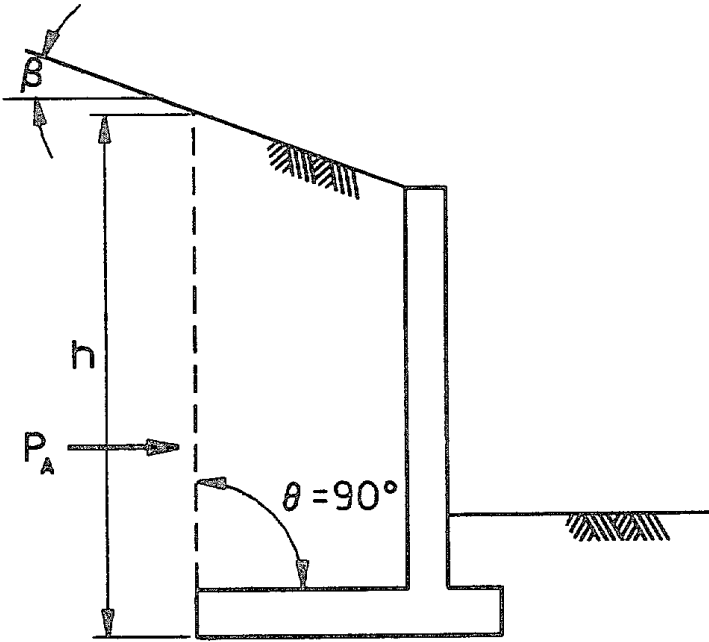
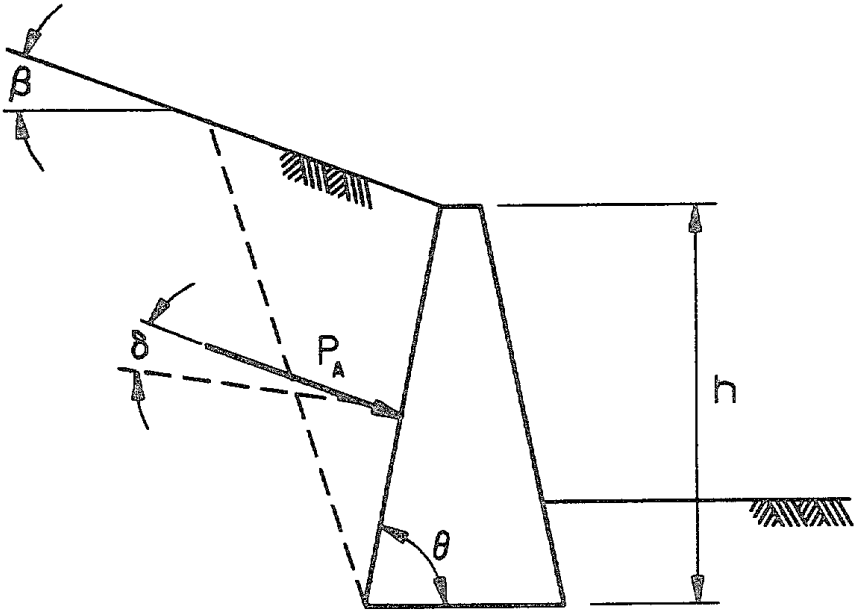

Figure 3-10. Variables used in Coulomb equation

(6) For the horizontal component of the earth force acting on a vertical plane, with no wall friction, the term $(1/\sin \theta \cos \delta)$ in Coulomb's equation is equal to unity. Thus, Equation 3-11 reduces to

$$P_{AH} = \left(\frac{1}{2}\right) K_A \gamma' h^2 \quad [3-16]$$

(7) If total stress or undrained strength parameters are used and there is a cohesion term c it has the effect of reducing the active earth force P_{AH} :

$$P_{AH} = \left(\frac{1}{2}\right) K_A \gamma' h^2 - 2c\sqrt{K_A} h + \frac{2c^2}{\gamma'} \quad [3-17]$$

For a backfill with a horizontal surface, K_c given in Appendix H, paragraph H-2c, equals $\sqrt{K_A}$. The second term is the reduction in the active force due to the effect of cohesion on the slip plane and the third term accounts for the shortened length of slip plane due to the effect of a tension crack. If the third term is neglected, and K is assumed constant with depth, the active pressure can be obtained as the derivative of P_{AH} with respect to the depth from the top of the wall z :

$$P_{AH} = K_A \gamma' z - 2c\sqrt{K_A} \quad [3-18]$$

Refer to examples 5 and 8 of Appendix M for examples involving cohesion.

(8) Estimation of at-rest pressures using the SMF concept with Coulomb's equation may give unreliable results for medium to highly plastic cohesive materials. If these materials cannot be avoided in the area of the driving side wedge, the at-rest pressure should be taken as the overburden pressure times an empirical K value, such as from Massarsch's (1979) or Brooker and Ireland's (1965) correlation of K with the plasticity index. Because of the number of uncertainties about the behavior of cohesive materials, a degree of conservatism should be exercised in the selection of the K values. Also, the effects of short and long term conditions (paragraph 3-5c) and compaction (paragraph 3-17) should be included in estimating the at-rest pressure.

c. Resisting-Side Earth Force.

(1) The Coulomb and general wedge equations assume a plane slip surface. However, wall friction effects cause the actual slip surface at failure to be curved. For active pressure calculations, the magnitude of error introduced by the plane surface assumption is not significant, as shown in Figure 3-9 (Driscoll 1979). Coulomb's passive force equation, however, is grossly unconservative where wall friction is present as shown in Figure 3-11 (Driscoll 1979). However, where δ is less than about one-third ϕ , the error is small. If wall friction is neglected, Coulomb's equation is therefore acceptable. The Coulomb passive pressure coefficient for the case of no wall friction ($\delta = 0$) and a vertical wall ($\theta = 90$ degrees) is:

$$K_P = \frac{\cos^2 \phi}{\left[1 - \sqrt{\frac{\sin \phi \sin (\phi + \beta)}{\cos \beta}} \right]^2} \quad [3-19]$$

For a horizontal backfill ($\beta = 0$), this reduces to

$$K_P = \frac{1 + \sin \phi}{1 - \sin \phi} = \tan^2 \left(45^\circ + \frac{\phi}{2} \right) = \frac{1}{K_A} \quad [3-20]$$

(2) If total stress or undrained strength parameters are used and there is a cohesion term c , it has the effect of increasing the passive earth force p_{PH} :

$$p_{PH} = \frac{1}{2} K_P \gamma' h^2 + 2c\sqrt{K_P} h \quad [3-21]$$

By differentiating p_{PH} with respect to the depth from the top of the resisting wedge z , the passive pressure may be obtained as:

$$p_{PH} = K_P \gamma' z + 2\sqrt{K_P} c \quad [3-22]$$

3-13. Earth Force Calculation, General Wedge Method.

a. General. The general wedge method refers to a limit equilibrium analysis of a set of assumed rigid bodies (soil and/or structural elements)

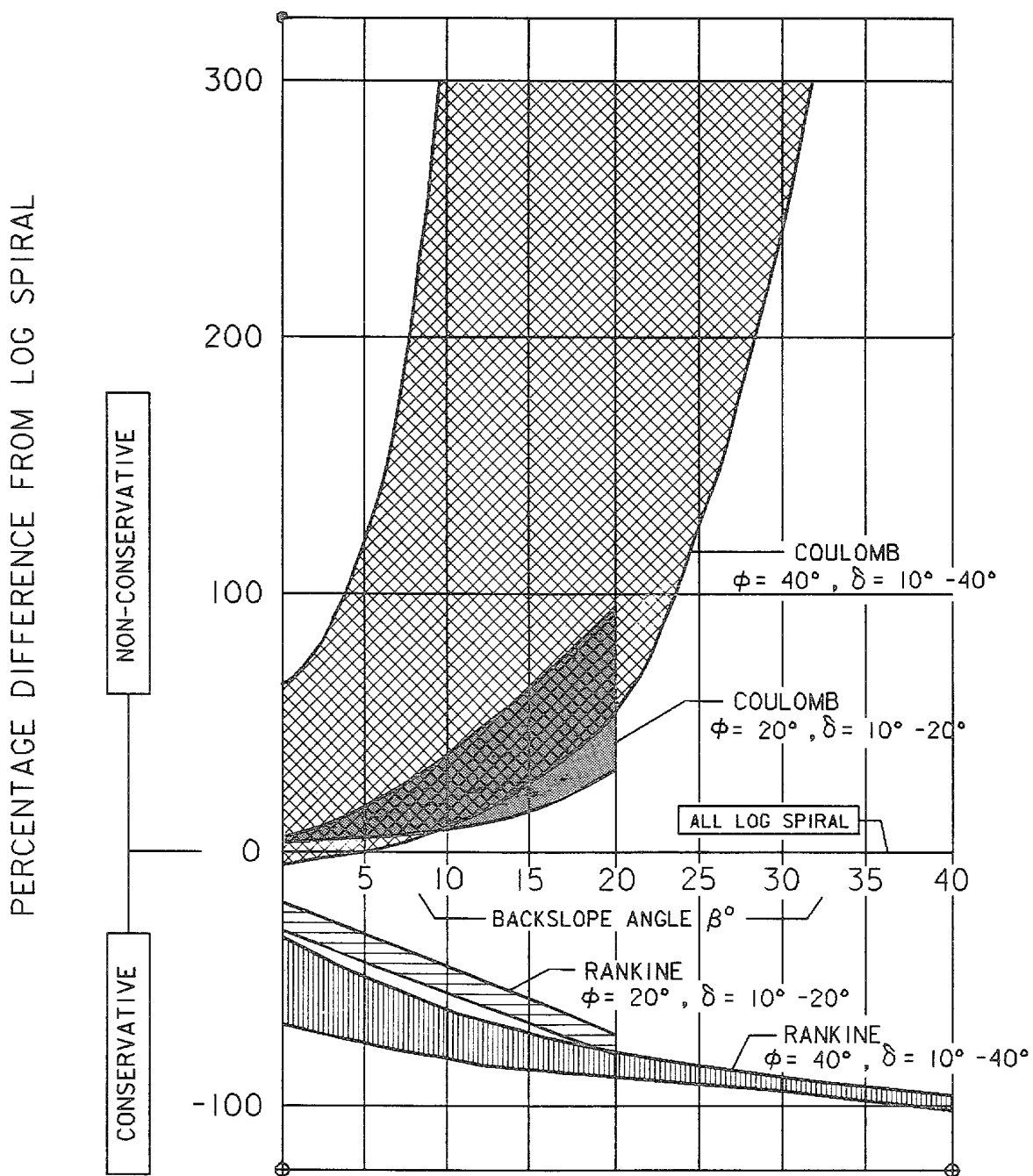

NOTE: Log spiral calculations based upon Caquot and Kerisel coefficients.

Figure 3-11. Comparison of passive earth pressures (after Driscoll 1979)

termed wedges. The horizontal earth force on the driving or resisting side of a retaining structure may be estimated by such an analysis employing properly chosen strength parameters. Where the special conditions listed in paragraph 3-12a(1) apply, the weight of the sliding mass and orientation of the critical sliding plane are unique functions of the backfill geometry and soil properties, and Coulomb's equations provide direct solutions for the driving and resisting earth forces. Where one or more of the variables in Coulomb's equation cannot be accommodated as a single value (such as the case with multiple soils where not all of the soil layers are horizontal, location of the water table, irregular backfills or where nonuniform surcharges are present), the critical inclination of the sliding surface and, in turn, the gravity forces (weight plus surcharges) on the sliding mass must be solved in order to calculate the horizontal earth force. In these cases, this requires a trial and error solution using the general wedge equation.

b. Use in Practice. When used with unfactored soil strength parameters, the general wedge equations yield the active and passive earth forces. When c and $\tan \phi$ are factored by an SMF value of 2/3, solution of the driving-side wedge provides an estimate of the at-rest earth forces (see paragraph 3-12). An SMF of 2/3 is not used to compute the resisting wedge force for the overturning, bearing, and structural design of the wall since a larger resisting force than is acceptable would be computed. See paragraph 3-8 for the procedure recommended to determine the resisting force for overturning and bearing capacity analyses and structural design of the wall.

c. Driving Side Earth Force, General Wedge Method.

(1) Wedge Geometry and Forces. The geometry of a typical driving-side wedge and its free-body diagram are shown in Figure 3-12. The angle of wall friction and the shear force between vertical wedge boundaries are assumed to be zero. The inclination of the slip surface α is that which maximizes the earth force. Calculation of α is discussed in paragraphs 3-13c(2) and 3-13c(4). If force equilibrium is satisfied, the forces on the wedge form a closed-force polygon as shown in Figure 3-13. The equation for the effective horizontal earth force P_{EE} exerted by a driving-side wedge on a wall or an adjacent wedge is given by the general wedge equation as:

$$P_{EE} = \frac{(W + V) (1 - \tan \phi_d \cot \alpha) \tan \alpha}{1 + \tan \phi_d \tan \alpha} + \frac{U \tan \phi_d - c_d L}{\cos \alpha (1 + \tan \phi_d \tan \alpha)} + H_L - H_R - P_W \quad [3-23]$$

where

- P_{EE} = effective horizontal earth force contributed by wedge or wedge segment
- W = total wedge weight, including water
- V = any vertical force applied to wedge
- α = angle between slip plane and horizontal
- U = uplift or buoyancy force acting on and normal to wedge slip plane
- L = length along the slip plane of the wedge
- H_L = any external horizontal force applied to the wedge from the left, acting to the right
- H_R = any external horizontal force applied to the wedge from the right, acting to the left
- P_W = internal water force acting on the side of the wedge free body (P_W is equal to the net difference of the water force for wedge segments with water on two vertical sides as shown in Figures 3-12 and 3-13.)

The developed strength parameters $\tan \phi_d$ and c_d are as defined in paragraph 3-11. Equation 3-23 is derived for failure occurring from left to right. All values are positive in the directions indicated in Figure 3-12. Refer to Appendix M for examples using Equation 3-23.

(2) Critical Value of Slip-Plane Angle.

(a) The critical value of α for a driving-side wedge with a horizontal top surface and a uniform surcharge or no surcharge is:

$$\alpha = 45^\circ + \frac{\phi_d}{2} \quad [3-24]$$

(b) For the special case of a backfill with a planar (flat or inclined) top surface and a strip surcharge V , the following equation can be used to compute the critical α value:

$$\alpha = \tan^{-1} \left(\frac{c_1 + \sqrt{c_1^2 + 4c_2}}{2} \right) \quad [3-25]$$

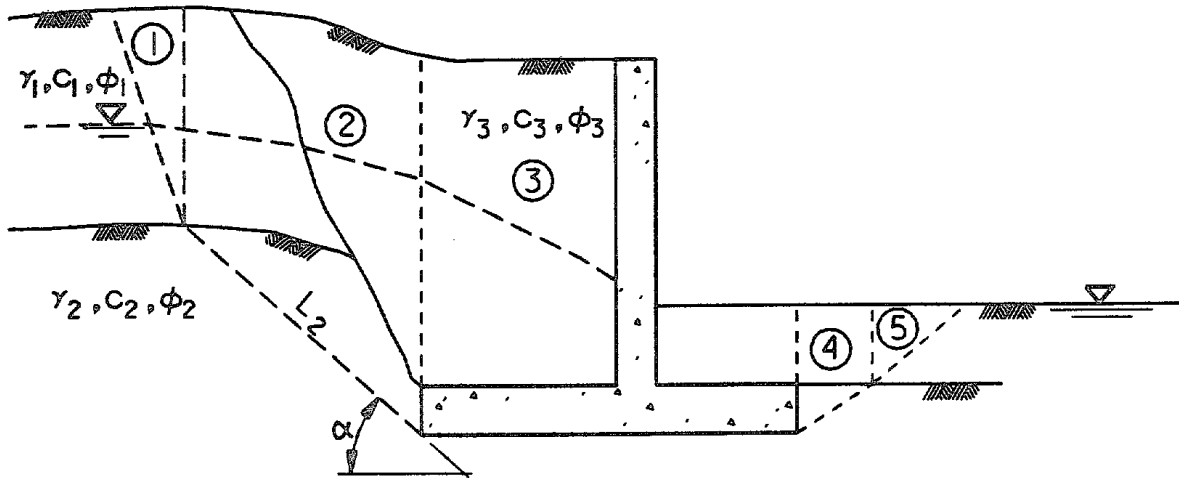

a. Estimation of forces using slices

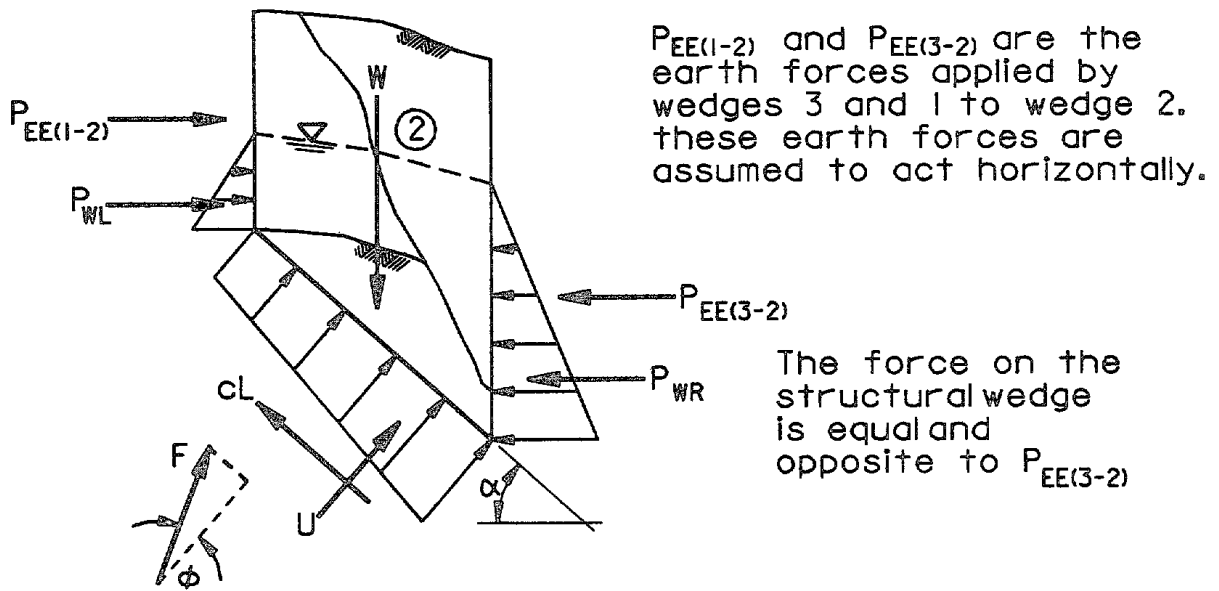

b. Free body of wedge 2

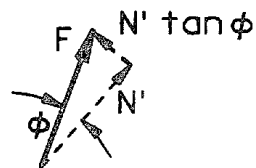

c. Derivation of force F

Figure 3-12. Wedge method on driving side

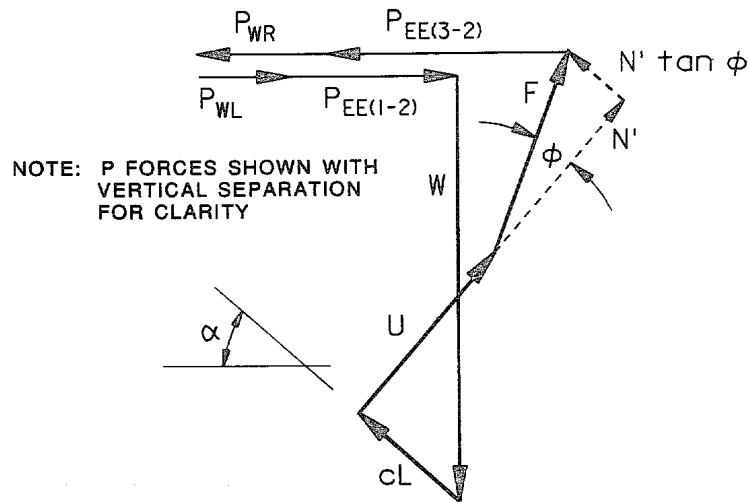

Force on driving side of structural wedge (slice 3) is equal and opposite to $P_{EE(3-2)}$. The force P_{EE} added by the wedge is $(P_{EE(3-2)} - P_{EE(1-2)})$ and acts to the right. The force P_W is equal to $P_{WR} - P_{WL}$ and acts to the right.

Figure 3-13. Force polygon for wedge method on driving side

The above equation for α assumes that the backfill is completely above or completely below the water table, but can be used when the water table is anywhere within the backfill with sufficient accuracy for design. The surcharge V can have any arbitrary shape but must be contained entirely within the driving wedge. The equations for c_1 and c_2 are:

(i) For a cohesionless backfill without a strip surcharge:

$$c_1 = 2 \tan \phi_d \quad [3-26]$$

$$c_2 = 1 - \tan \phi_d \tan \beta - \left(\frac{\tan \beta}{\tan \phi_d} \right) \quad [3-27]$$

(ii) For a cohesive or a cohesionless backfill with a strip surcharge:

$$c_1 = \frac{2 \tan^2 \phi_d + \frac{4c_d (\tan \phi_d + \tan \beta)}{\gamma(h + d_c)} - \frac{4V \tan \beta (1 + \tan^2 \phi_d)}{\gamma(h^2 - d_c^2)}}{A} \quad [3-28]$$

$$c_2 = \frac{\tan \phi_d (1 - \tan \phi_d \tan \beta) - \tan \beta + \frac{2c_d (1 - \tan \phi_d \tan \beta)}{\gamma(h + d_c)} + \frac{2V \tan^2 \beta (1 + \tan^2 \phi_d)}{\gamma(h^2 - d_c^2)}}{A} \quad [3-29]$$

where

$$A = \tan \phi_d + \frac{2c_d (1 - \tan \phi_d \tan \beta)}{\gamma(h + d_c)} - \frac{2V (1 + \tan^2 \phi_d)}{\gamma(h^2 - d_c^2)} \quad [3-30]$$

These equations when applied to a cohesive backfill are subject to the limitations described in paragraph 3-12b(8). The derivation of these equations is shown in Appendix G. Examples using these equations are shown in Appendix M.

(c) For irregular backfills, obtaining the critical inclination of the driving-side slip surface may require a trial-and-error solution. As a first approximation, the backfill surface may be bounded by two inclined lines originating from the top of the wall and the value of α may be calculated using an "average" β value between the two bounding lines (Figure 3-14), or by introducing a surcharge as shown in Example 9 of Appendix M.

(3) Limitations of Critical Slip Plane Equations. The equations for c_1 and c_2 are valid except when the strip surcharge V is too large or when the slope of the top surface is too great. The maximum value for the strip

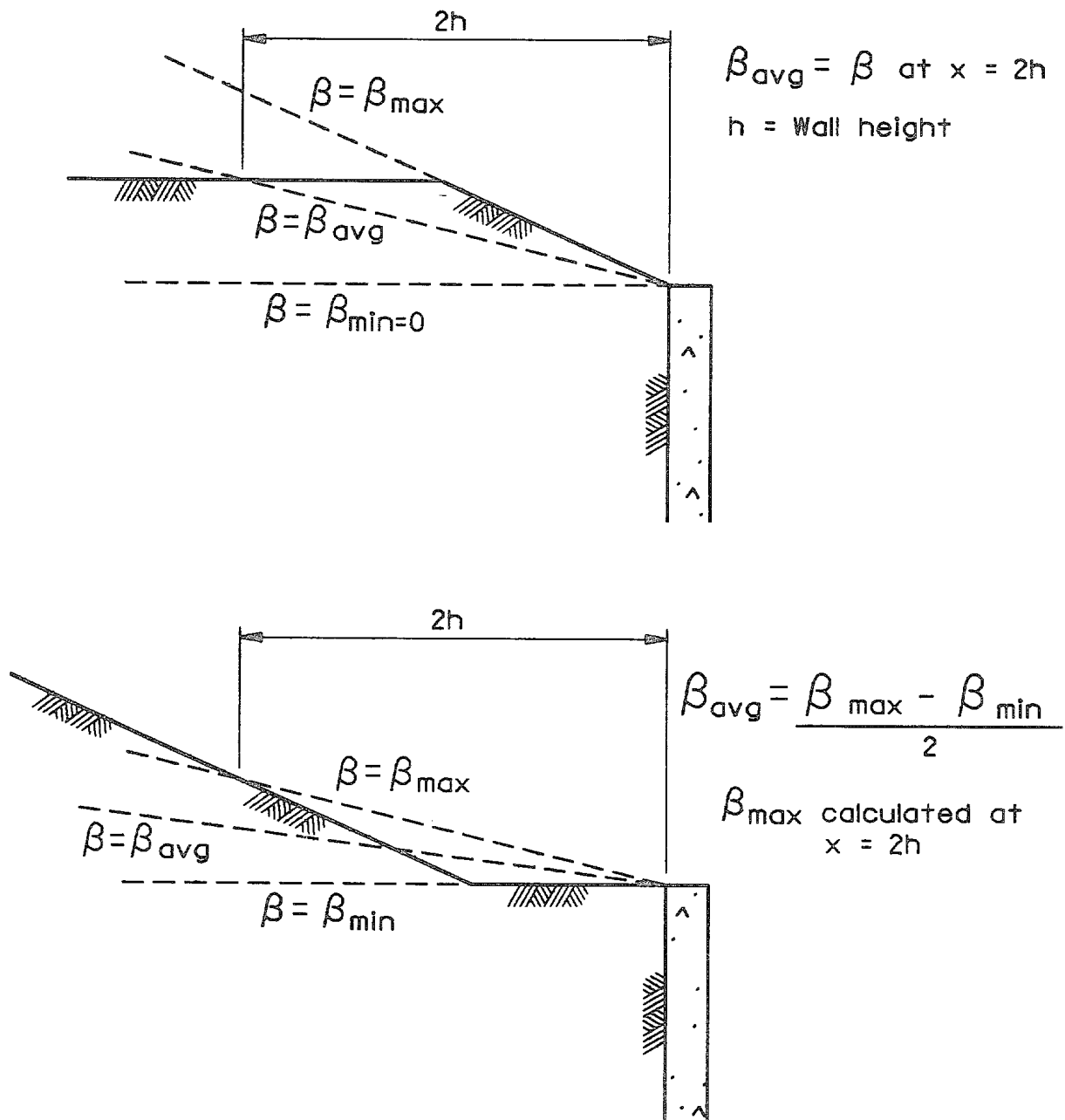

Critical value of α is between α calculated using β_{min} and β_{max} . Use β_{avg} for first trial.

Figure 3-14. Wedge analysis for irregular backfill

surcharge is determined by setting the denominator of the equation for c_1 or c_2 equal to zero and solving for V . This value is:

$$V_{\max} = \frac{\gamma(h^2 - d_c^2) \tan \phi_d + 2c_d(h - d_c)(1 - \tan \phi_d \tan \beta)}{2(1 + \tan^2 \phi_d)} \quad [3-3]$$

When $V \geq V_{\max}$ the value of α is set by the location of the strip surcharge as shown in Figure 3-15, and given by the equation

$$|\alpha| = \tan^{-1} \frac{h - d_c + (S) \tan \beta}{S} \quad [3-32]$$

Even when $V < V_{\max}$, a check should be made to be certain that the entire strip surcharge lies on the top surface of the wedge as defined by the calculated value of α . Also, when $c_1^2 + 4c_2 < 0$, α is indeterminate. This is an indication that the slope of the top surface is too great to be sustained by the developed strength parameters $\tan \phi_d$ and c_d . See example 8 in Appendix M for a solution to this problem.

(4) Layered Soils. The wedge equations imply a single set of strength parameters along the wedge base. For layered soils, the wedge must be divided into wedge segments, each with its base in a single soil. The wedge base inclinations α are theoretically different in every soil (Figure 3-16a); calculation of an optimum solution (maximized earth force) for the set of α values is tedious and cumbersome. Three approximate methods may be used:

(a) The critical inclination in each layer may be calculated according to Equation 3-25 using the developed shear strength parameters for the soil along the wedge base and using the slope angle β at the top of each wedge segment (see Figure 3-16a).

(b) The wedge segment bases may be assumed to have a constant inclination α through all materials and the critical value (corresponding to the maximum driving side force) may be calculated by trial using Equation 3-23 (see Figure 3-16b).

(c) Alternatively, the critical slip-plane angle may be calculated (for each layer below the top layer) by using the procedure presented in paragraph G-7 of Appendix G (see example 6 in Appendix M).

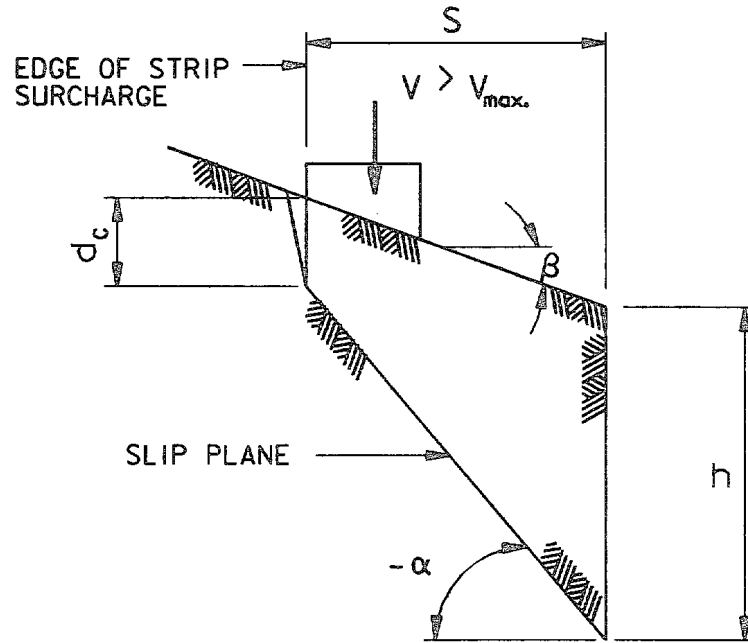

$$S = \frac{h - d_c}{\tan \alpha - \tan \beta}$$

$$\tan \alpha = \frac{h - d_c}{S} + \tan \beta = \frac{h - d_c + S \tan \beta}{S}$$

$$|\alpha| = \tan^{-1} \left(\frac{h - d_c + S \tan \beta}{S} \right)$$

Figure 3-15. Surcharge effect on critical slip plane

$$\alpha_1 = f(\phi_{a1}, \beta_1)$$

etc....

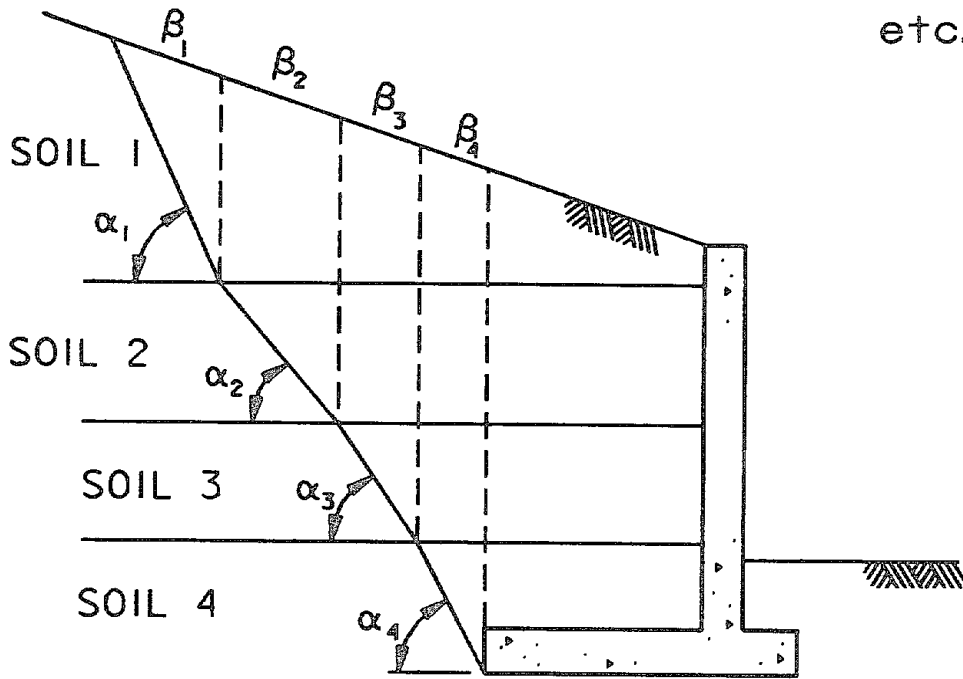

a. Wedge 1

$$\alpha = f(P_{max})$$

Found by trial

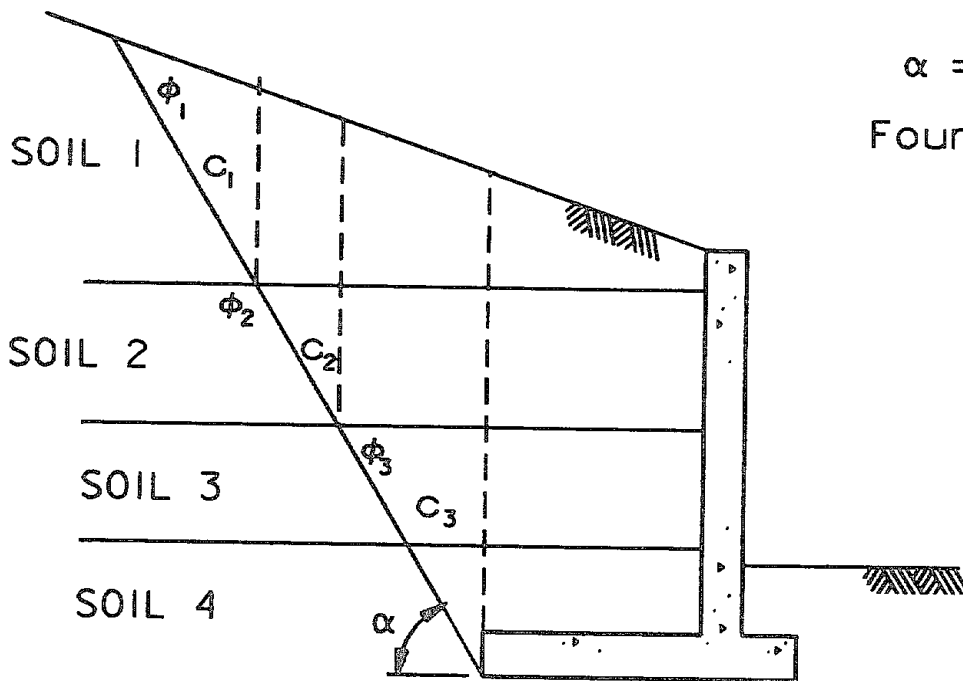

b. Wedge 2

Figure 3-16. Wedge analysis in layered soil

29 Sep 89

If the surfaces of all layers are horizontal, the critical slip plane may be determined using Equation 3-24.

(5) Surcharges. The wedge method incorporates surcharge effects into the resultant earth force if the surcharge force is added to the wedge weight. However, it is preferable to calculate horizontal pressures due to surcharges separately for the following reasons:

(a) The presence of a nonuniform surcharge alters the principal stress directions, increasing the curvature of the slip surface, and increasing the error associated with assuming a plane surface.

(b) Stresses induced by surcharges are distributed throughout a soil mass in a manner that may considerably alter the point of application and distribution of earth pressure as further described in paragraph 3-16. Limit-equilibrium techniques and the earth pressure coefficient concept do not accurately predict such distributions.

(c) The additional pressures developed on the wall depend on the amount of wall movement and may be twice as great for nonyielding walls as for yielding walls.

The intent of this manual is to consider walls to be relatively rigid and to design for at-rest conditions. Therefore, pressures and forces due to non-uniform surcharges should be calculated in accordance with paragraph 3-16, adding the results to the pressures and/or forces obtained from Coulomb's equation or the general wedge equation. For the sliding analysis, surcharge effects may be included directly in the wedge method weight calculations because the sliding analysis considers only force equilibrium; thus, the point of application of the forces does not matter. Examples 4 and 10 of Appendix M demonstrate the calculation of horizontal pressures involving surcharges.

(6) Pressure Coefficients.

(a) Structural engineers are familiar with the use of Coulomb's equations (paragraph 3-12) for the determination of earth pressure coefficients and the use of these coefficients in determining pressures and forces acting on retaining walls. These equations suffer from several limitations as discussed in paragraph 3-12a(1). The general wedge equation (Equation 3-23) is not subject to any of the limitations of Coulomb's equations and may be used to solve for the lateral earth force on a wedge due to complicated geometry and surface loading. If lateral earth pressure coefficients are derived from the general wedge equation, these coefficients may be used in a rather simple manner to solve complex earth pressure problems.

(b) Earth pressures can be calculated from general wedge method solutions by assuming that pressures vary in a piecewise linear fashion and that the slopes of the pressure diagrams are the product of densities and pressure coefficients (K). The slopes may be considered the density of an "equivalent fluid" loading the wall. These pressure coefficients are dependent on the

problem geometry and are derived in Appendix H. It should be noted that pressure coefficients (K values) below the water table may differ from those above the water table in the same material as shown in Appendix H. One example where the K value is different above and below the water table is the case of a sloping backfill. Examples using pressure coefficients are shown in Appendix M.

d. Resisting Side Earth Force, General Wedge Method.

(1) Wedge Geometry and Forces. The geometry of a typical resisting-side wedge and its free-body diagram are shown in Figure 3-17. The angle of wall friction and the shear force between vertical wedge boundaries are assumed to be zero. The inclination of the slip surface α is that which minimizes the earth force. Calculation of α is discussed in paragraph 3-13d(2). If force equilibrium is satisfied, the forces on the wedge form a closed force polygon as shown in Figure 3-17. The equation for the horizontal effective earth force P_{EE} exerted by a resisting-side wedge on a wall or an adjacent wedge is:

$$P_{EE} = \frac{(W + V)(1 + \tan \phi_d \cot \alpha) \tan \alpha}{1 - \tan \phi_d \tan \alpha} - \frac{U \tan \phi_d - c_d L}{\cos \alpha (1 - \tan \phi_d \tan \alpha)} - H_L + H_R - P_W \quad [3-33]$$

where the terms are the same as for the driving-side wedge equation (Equation 3-23). Equation 3-33 is derived for failure occurring from left to right. All values are positive in the directions indicated in Figure 3-17.

(2) Critical Value of Slip-Plane Angle.

(a) For a resisting-side wedge with a horizontal top surface, α can be computed as follows:

$$\alpha = 45^\circ - \frac{\phi_d}{2} \quad [3-34]$$

(b) The critical angle α for a resisting-side wedge with a planar (flat or inclined) top surface, with no surcharge or with a strip surcharge V , is given by the equation:

$$\alpha = \tan^{-1} \left[\frac{-c_1 + \sqrt{c_1^2 + 4c_2}}{2} \right] \quad [3-35]$$

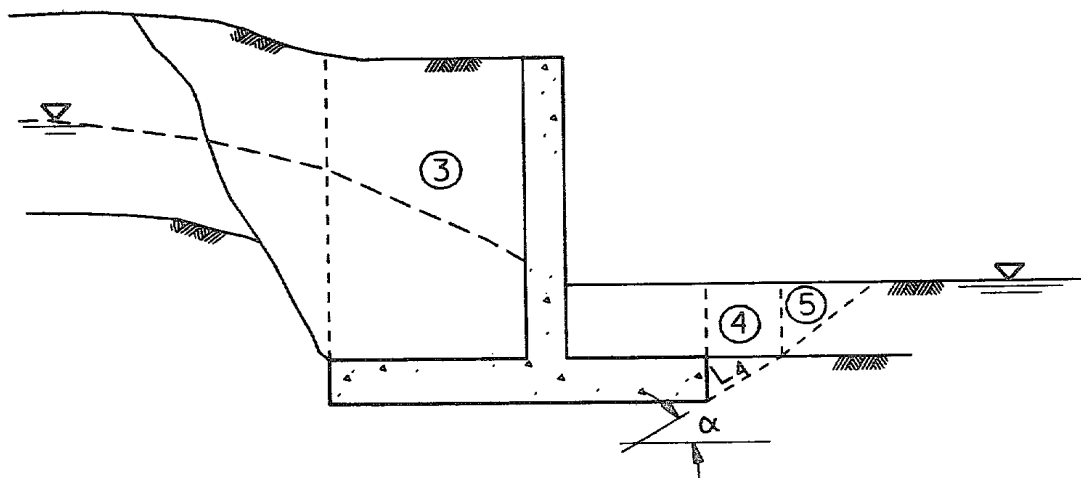

a. Estimation of forces using slices

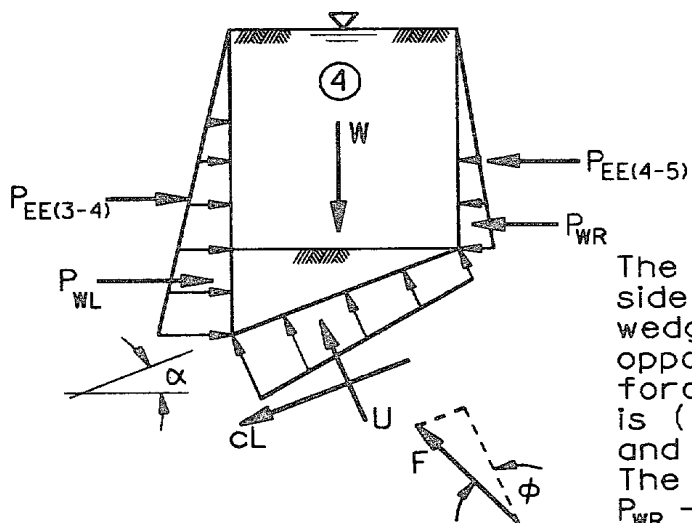

The force on the resisting side of the structural wedge is equal and opposite to $P_{EE(3-4)}$. The force P_{EE} added by the wedge is $(P_{EE(3-4)} - P_{EE(4-5)})$ and acts to the left. The force P_W is equal to $P_{WR} - P_{WL}$ and acts to the left.

b. Free-body diagram of slice 4

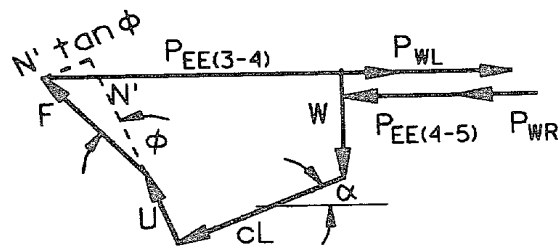

c. Force polygon for slice 4

Figure 3-17. Wedge method for resisting-side wedge

For a resisting-side wedge, the equations for c_1 and c_2 are

$$c_1 = \frac{2 \tan^2 \phi_d + \frac{4c_d (\tan \phi_d - \tan \beta)}{\gamma h} - \frac{4V \tan \beta (1 + \tan^2 \phi_d)}{\gamma h^2}}{A} \quad [3-36]$$

$$c_2 = \frac{\tan \phi_d (1 + \tan \phi_d \tan \beta) + \tan \beta + \frac{2c_d (1 + \tan \phi_d \tan \beta)}{\gamma h} - \frac{2V \tan^2 \beta (1 + \tan^2 \phi_d)}{\gamma h^2}}{A} \quad [3-37]$$

$$A = \tan \phi_d + \frac{2c_d (1 + \tan \phi_d \tan \beta)}{\gamma h} + \frac{2V (1 + \tan^2 \phi_d)}{\gamma h^2} \quad [3-38]$$

(3) Surcharges. The comments regarding surcharges in paragraph 3-13c(5) relative to analysis of driving-side wedges also apply in general to resisting-side wedges. However, surcharges on resisting-side wedges tend to enhance stability and therefore it is conservative to neglect them in analysis. If resisting-side surcharges are not neglected, it must be assured that the surcharge loading will be in place for the condition analyzed.

(4) Pressure Coefficients. Earth pressures for the resisting side may be calculated as equivalent fluid pressures in a manner similar to that for the driving side. See paragraph 3-13c(6) and Appendix H for further discussion.

3-14. Earth Pressure Calculations Including Wall Friction.

a. Driving Side. Friction between the backfill and wall, or on a plane within the backfill, of up to one-half of the internal friction angle (unfactored) of the backfill material may be used in the design.

b. Resisting Side. When wall friction is included in the analysis, assuming the slip surface to be a log-spiral or other curved surface provides lower and more reasonable values for the passive force and passive pressure coefficient K_p (see Figure 3-11). Although the angle of wall friction should generally be taken as zero, it may be assumed greater than zero where movement and settlement of the wall are expected and permissible. Figure 3-18 provides earth pressure coefficients for horizontal backfills based on the work of Caquot and Kerisel (1948) and Shields and Tolunay (1973).

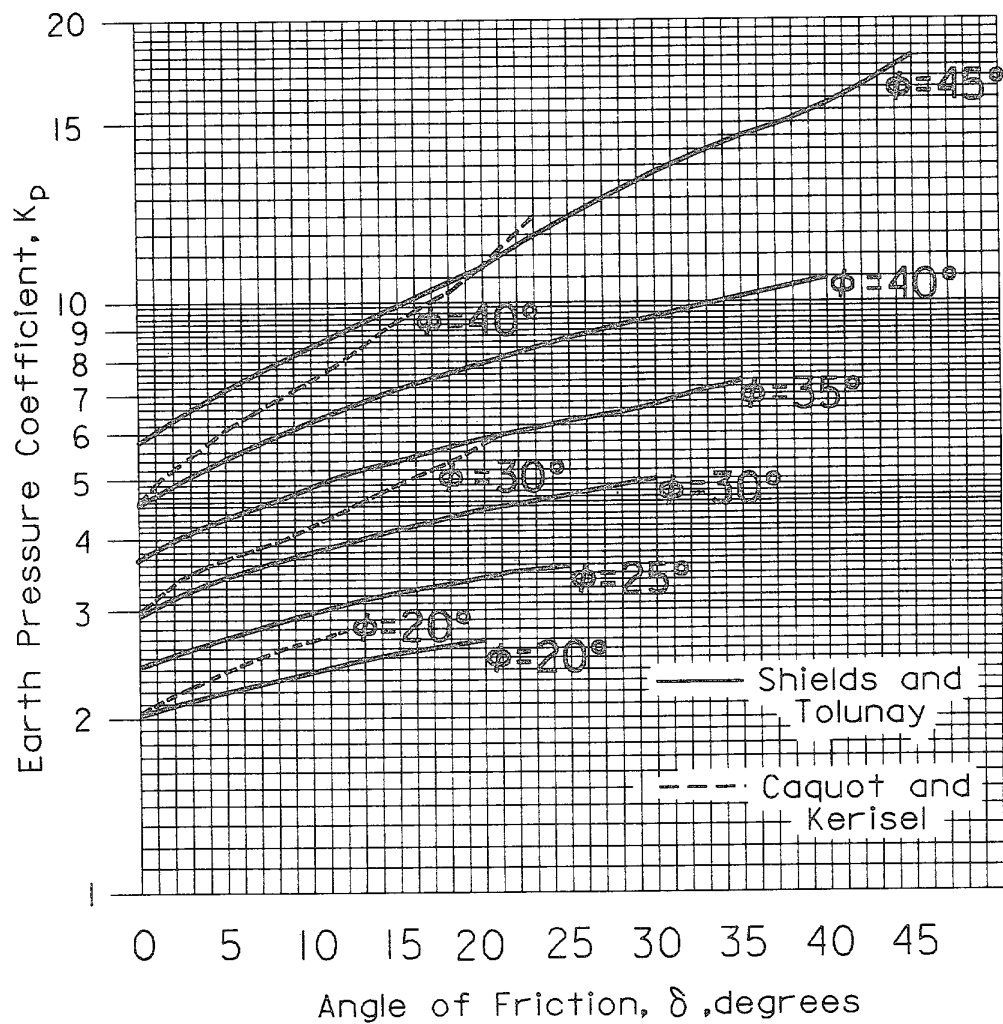

Figure 3-18. Passive earth pressure coefficients

3-15. Distribution of Horizontal Earth Pressure.

a. Superposition of Pressures. The distribution of total horizontal pressure on the driving or resisting side is obtained by superposing the distributions due to horizontal effective earth pressure, water, and surcharges. Where compaction efforts are specified, horizontal earth pressures should be calculated in accordance with paragraph 3-17.

b. Soils Completely Above or Completely Below the Water Table. The effective earth pressure may be assumed to have a triangular distribution when all of the following conditions hold:

- (1) The wall will not move or it will rotate about the base.

- (2) The water table is at or below the base of the wall or at or above the top of the wall (submerged soil).
- (3) Water conditions are hydrostatic (no seepage).
- (4) There is only one soil material.
- (5) There is no cohesion ($c = 0$).
- (6) The backfill surface is plane (it may be inclined).

The distribution is given by:

$$p'_{hz} = K\gamma'z \quad [3-39]$$

where

$K = K_o$ on the driving side. K for the resisting side could vary between K_p and K_o or could be taken as zero

γ' = the effective unit weight (total, saturated or moist unit weight if above the water table, buoyant or submerged unit weight if below the water table)

z = vertical distance measured down from the backfill surface

See Figure 3-19 for an example.

c. Partly Submerged Soils. Where the water table occurs between the top and the base of the wall, and only one soil is present, the top portion of the pressure diagram is a triangle given by Equation 3-39 and the bottom is a trapezoid given by:

$$p'_{hz} = K[\gamma z_w + \gamma' (z - z_w)] \quad [3-40]$$

where

z_w = depth to water table

$\gamma' = (\gamma - \gamma_w)$ below the water table

An example is shown in Figure 3-20. See Appendix H where water table and backfill surface are not parallel.

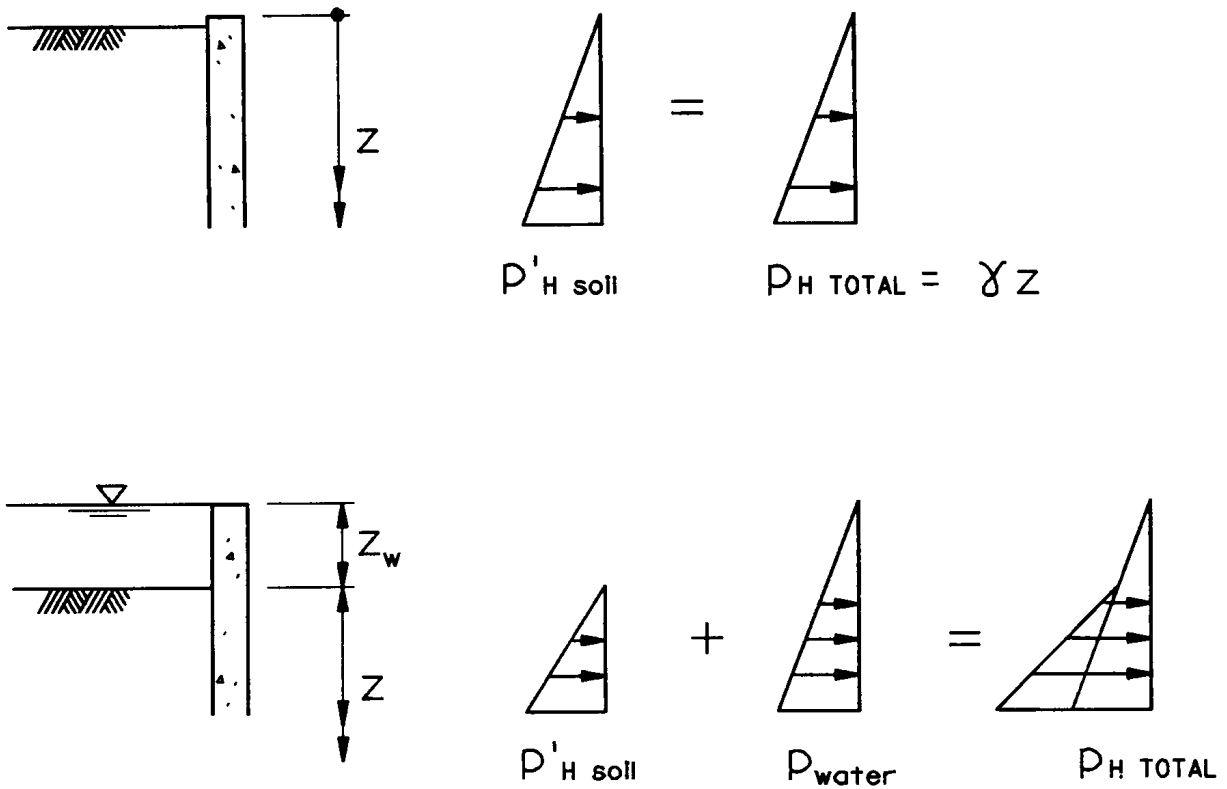

$$\begin{aligned}
 P_v &= P_v + P_{\text{water}} \\
 &= \gamma_w z_w + \gamma z \\
 P'_v &= P_v - P_{\text{water}} \\
 &= \gamma_w z_w + \gamma z - \gamma_w (z_w + z) \\
 &= (\gamma - \gamma_w) z \\
 &= \gamma' z \\
 P'_H &= K \gamma' z
 \end{aligned}$$

Figure 3-19. Lateral pressures, one soil completely above water table or completely below water table

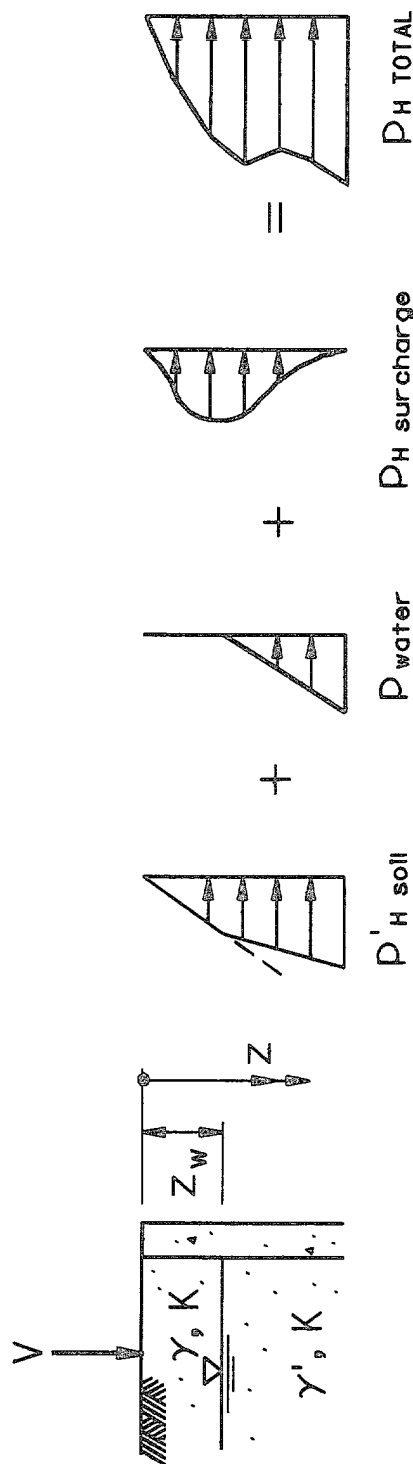

Figure 3-20 Lateral pressures, one soil, water, finite surcharge

d. Layered Soils. Where layered soils are present, the pressure diagram is a triangle underlain by a series of trapezoids given by:

$$p'_{hz} = K_i (p'_{vi} + \gamma'_i z_i) \quad [3-41]$$

where

- K_i = horizontal earth pressure coefficient for the i^{th} layer
- p'_{vi} = vertical effective earth pressure at the top of the i^{th} layer
- γ'_i = effective unit weight of the i^{th} layer
- z_i = vertical distance measured down from the top of the i^{th} layer

An example is shown in Figure 3-21.

e. Irregular Backfills. Where the backfill is irregular, the pressure diagram may be estimated by performing successive wedge analyses at incremental depths from the top of the wall and applying the force difference from successive analyses over the corresponding vertical area increment (Agostinelli et al. 1981). Since this procedure is approximate, increasing the number of calculation points does not necessarily increase accuracy. An example of this procedure is shown in Figure 3-22. The pressure diagram may also be estimated by the use of pressure coefficients (see paragraphs 3-13c(6)) as shown in examples 7, 8, and 9 of Appendix M.

f. Cohesion Effects.

(1) Where the backfill is horizontal and where cohesion is present, its theoretical effect is to reduce the driving side earth pressure by $2c \sqrt{K_A}$ for the entire depth of the soil layer (see Equation 3-18). This infers tension in the soil to a "crack depth" d_c where

$$d_c = \frac{2c_d}{\gamma' \sqrt{K_A}} \quad [3-42]$$

Consequently there is zero load on the wall in this region. For sloping backfills, see Appendixes H and I. Where cohesion is present, a water-filled tension crack should be considered in the inferred tension zone. The maximum crack depth using the unfactored c value should also be checked. Where the horizontal earth force is calculated from a pressure diagram that includes negative pressure, the force reduction due to the inferred negative pressure zone should be taken as zero. The pressure on the driving side should be

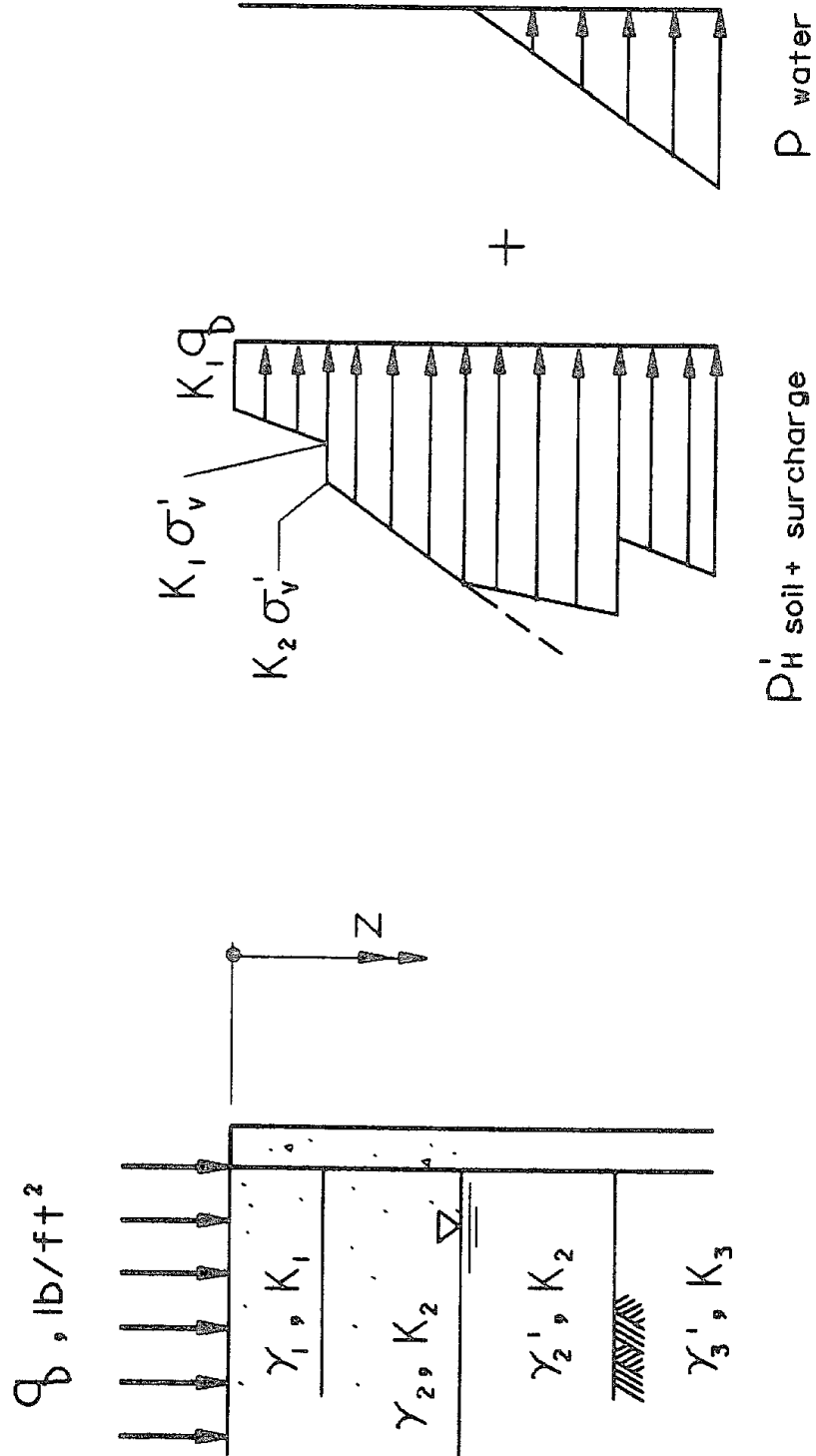

Figure 3-21. Lateral pressures, three soils, water

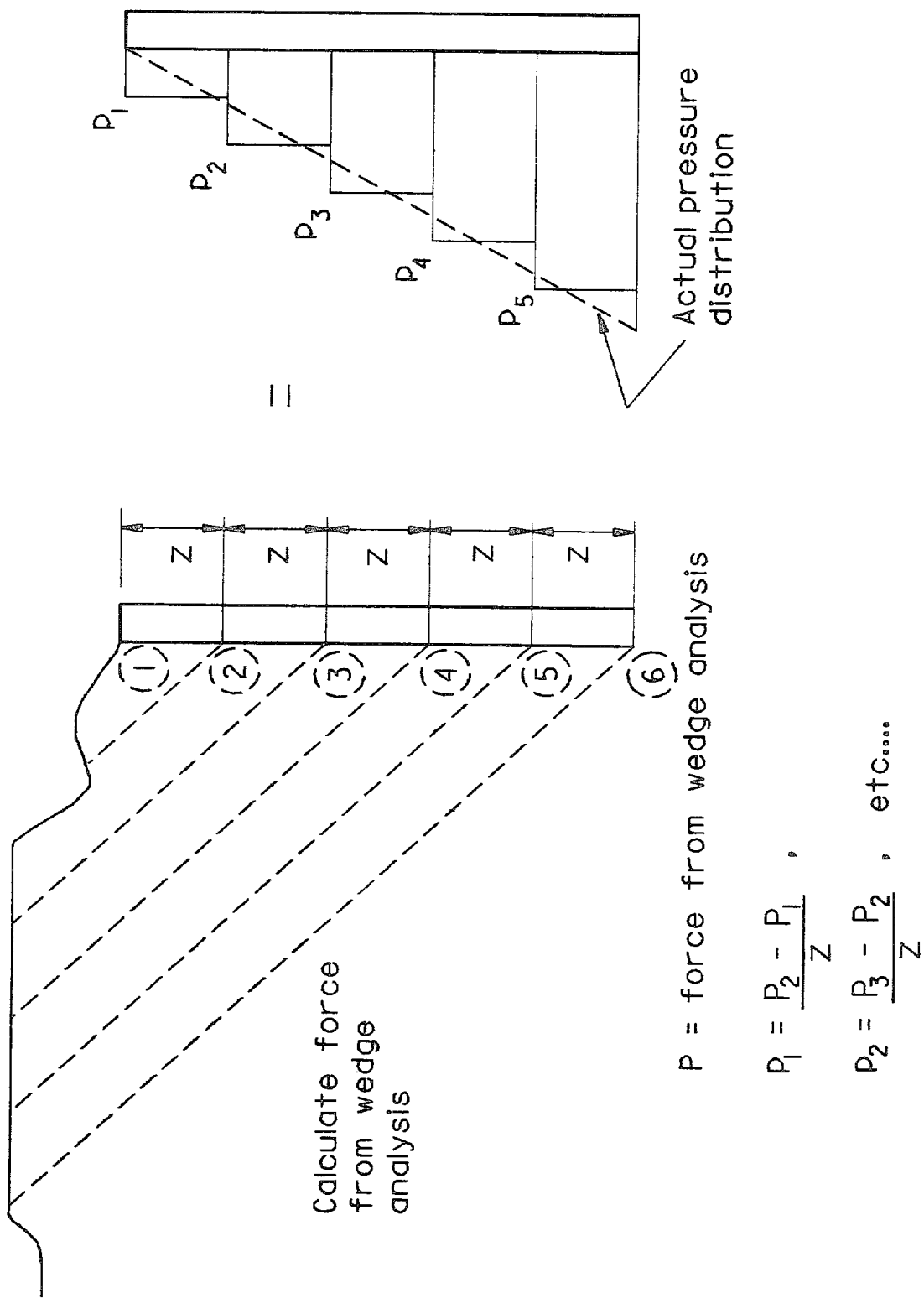

Figure 3-22. Pressure distribution due to irregular backfill

computed using Equation 3-18 by setting the 2nd term equal to 0 and K_A equal to K_O and using the pressure distribution as shown in Figure 3-23.

(2) For the resisting side, passive pressure theory indicates no tension crack will form and the pressure would be calculated using Equation 3-22. The pressure distribution for a cohesive soil on the resisting side of a structure is shown in Figure 3-24. However, for operating conditions without movement, a tension crack may form due to moisture loss reducing or eliminating the resisting side pressure. See paragraph 3-8 for resisting pressure to be used for design.

(3) Refer to guidance on use of cohesive materials in paragraph 3-5.

g. Wall Movement Effects.

(1) Where the expected mode of wall movement is translation and/or rotation about a point other than the base (such as for braced walls) the value of K varies with depth and the horizontal earth pressure distribution will be parabolic rather than triangular. Solution methods for such conditions are less reliable than those for rotation about the base. Available methods include Rendulic's procedure (Winterkorn and Fang 1975), Dubrova's procedure (Harr 1977), and a procedure given by Wu (1966).

(2) Where the expected mode of wall movement is translation and/or rotation about a point other than the base, the force may be assumed the same as that obtained for rotation about the base, but the point of application should be taken at 45 percent of the wall height above the base.

3-16. Surcharge Effects.

a. Uniform Surcharges. Where uniform surcharges (q) are present, the vertical effective stress increases by the amount of the surcharge and the horizontal earth pressure diagram is a trapezoid given by:

$$p'_{hz} = K(q + \gamma'z) \quad [3-43]$$

An example is shown in Figure 3-21.

b. Finite Surcharges.

(1) Pressure Increase Due to Finite Surcharges. The distribution of the horizontal pressure increase due to finite surcharges should be calculated using experimentally modified elastic theory where expected (or allowable) strains due to the surcharge are small. Pressures due to point and line loads can be calculated using Figures 3-25 and 3-26, respectively. The resulting pressures are about twice as great as would be obtained from either unadjusted elastic solutions or limit-equilibrium solutions. This difference is due to wall rigidity not considered in elastic or limit-equilibrium methods. Pressures due to strip loads can be calculated using Figure 3-27. Pressures due

$$P_{HZ} = P'_{H \text{ soil}} + P_{\text{water}}$$

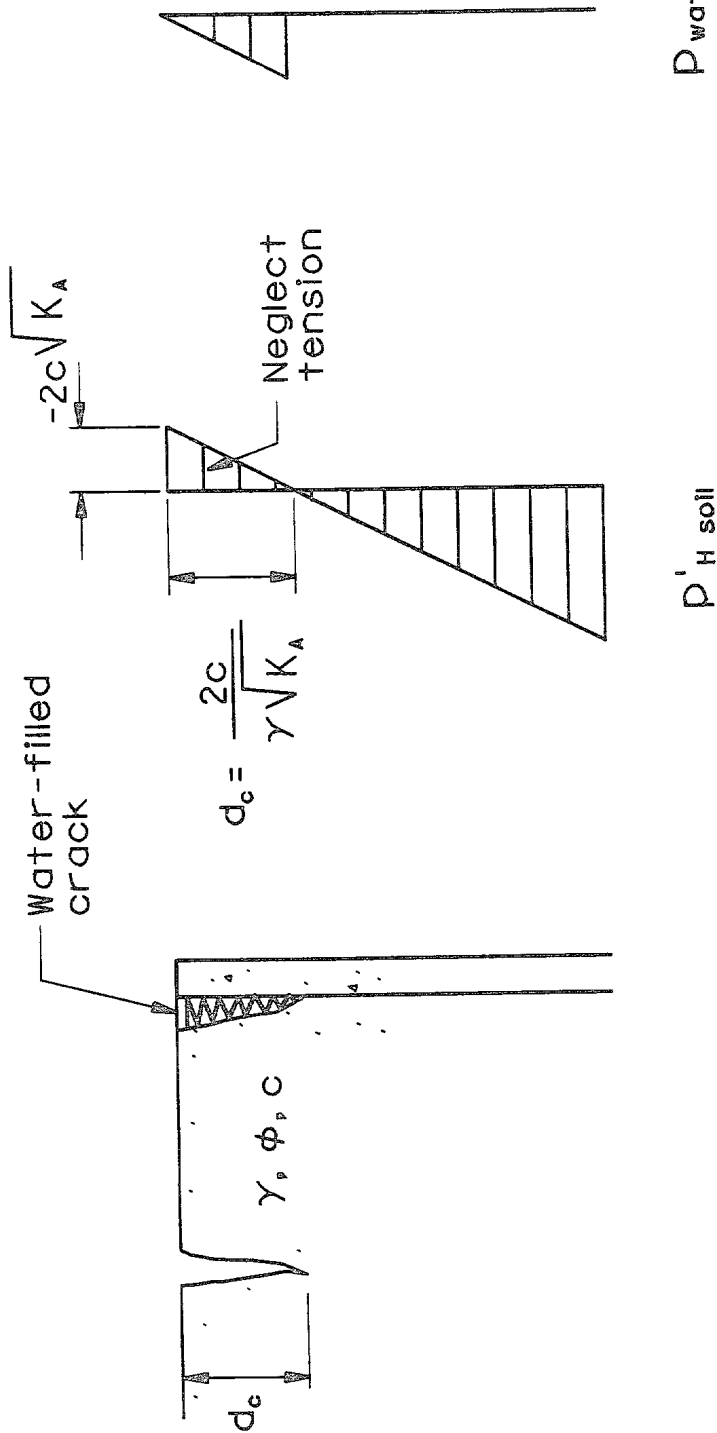
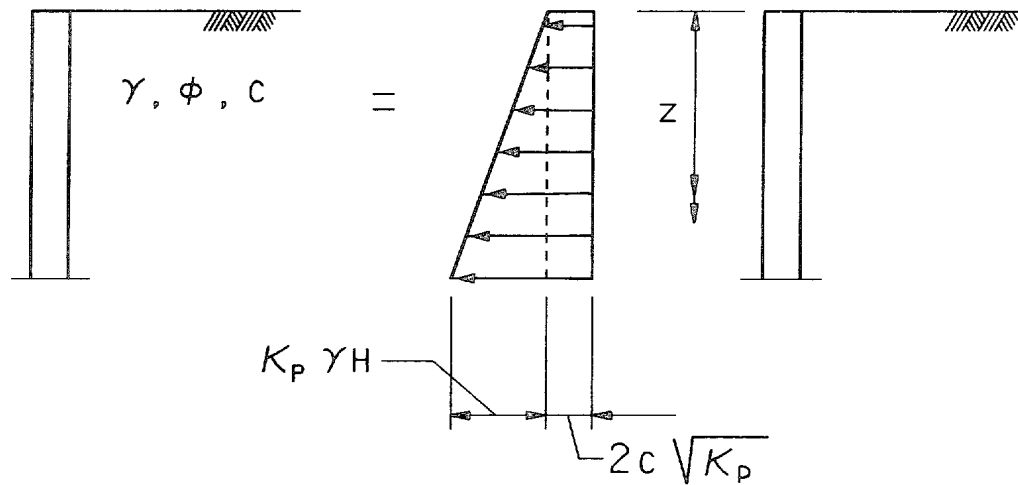

Figure 3-23. Lateral pressure distribution; active case, soil with cohesion



$$P_{PH} = K_p \gamma' z + 2c \sqrt{K_p}$$

Figure 3-24. Lateral pressure distribution; passive case, soil with cohesion

to strip surcharge loads of more general shapes can be calculated by applying the principle of superposition to these solutions; a pressure-intensity curve of any shape can be modeled to any desired degree of accuracy as the sum of point, line, or strip loads. Example computations involving surcharges are shown in examples 4 and 10 of Appendix M.

(2) Force Due to Finite Surcharges. Point, line, or nonuniform (finite) surcharge loads are supported by distribution or "diffusion" of stresses within the backfill material. These result in a curved pressure diagram; the point of application for the horizontal force resultant due to point or line loads is given in Figure 3-28. Where surcharge pressure distributions of a general shape have been modeled by superposition of these basic solutions, the point of application is found by dividing the total moment due to the surcharge resultants by the sum of the surcharge resultants. Where surcharge loadings are included in a wedge-method analysis, the difference in resultant force due to the surcharge (ΔP_H) should be applied at a different point on the wall from the resultant due to backfill weight. An approximate method for locating the line of action for a line load (Terzaghi 1943) is shown in Figure 3-29. An example using this approximate method is shown in example 4 of Appendix M.

3-17. Earth Pressures Due to Compaction. The use of heavy rollers for compaction adjacent to walls can induce high residual pressures against the wall. Although a reasonable degree of compaction is necessary to provide adequate shear strength and minimize settlement, excess backfill compaction should be avoided. Ingold (1979a,b) proposed a procedure for estimating lateral pressures due to compaction that has been modified herein (Appendix J) to account

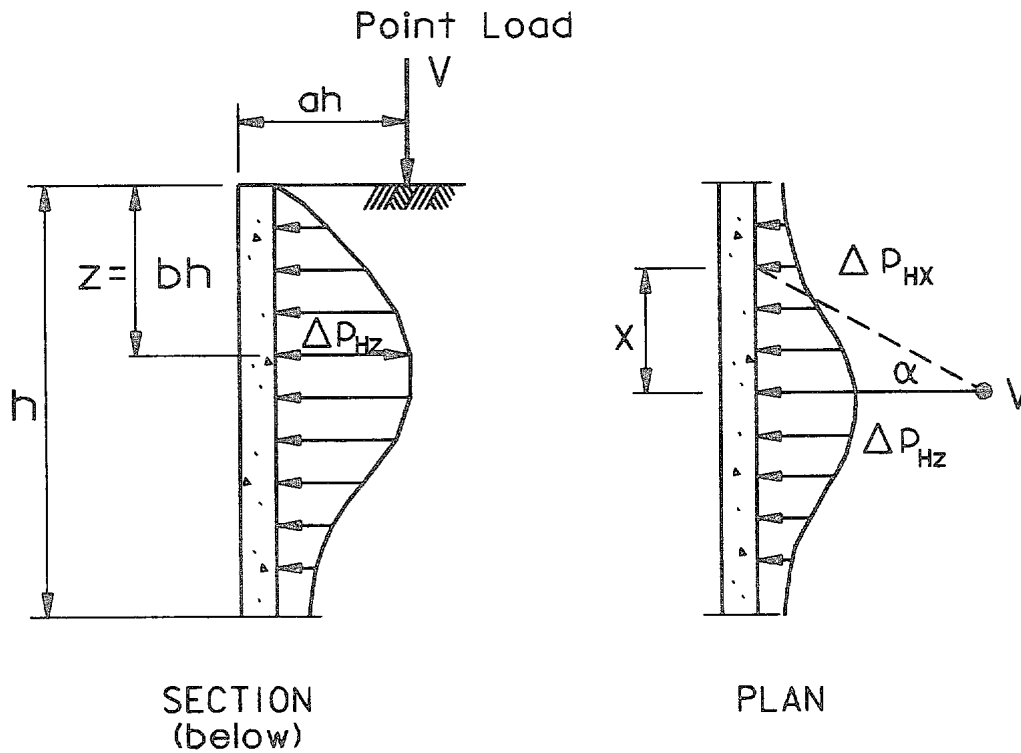

Increase in horizontal pressure, ΔP_{HZ} , on a section through point load, V

$$\Delta P_{HZ} = \left(\frac{V}{h^2} \right) \left(\frac{a^2 b^2}{(a^2 + b^2)^3} \right) \quad \text{for } a > 0.4$$

$$\Delta P_{HZ} = \left(\frac{0.28V}{h^2} \right) \left(\frac{b^2}{(0.16 + b^2)^3} \right) \quad \text{for } a \leq 0.4$$

Increase in horizontal pressure, ΔP_{HX} , at distance X from plane of load, V

$$\alpha = \tan^{-1} \left(\frac{X}{ah} \right)$$

$$\Delta P_{HX} = \Delta P_{HZ} \cos^2 (1.1 \alpha)$$

Figure 3-25. Increase in pressure due to point load (after Spangler 1956)

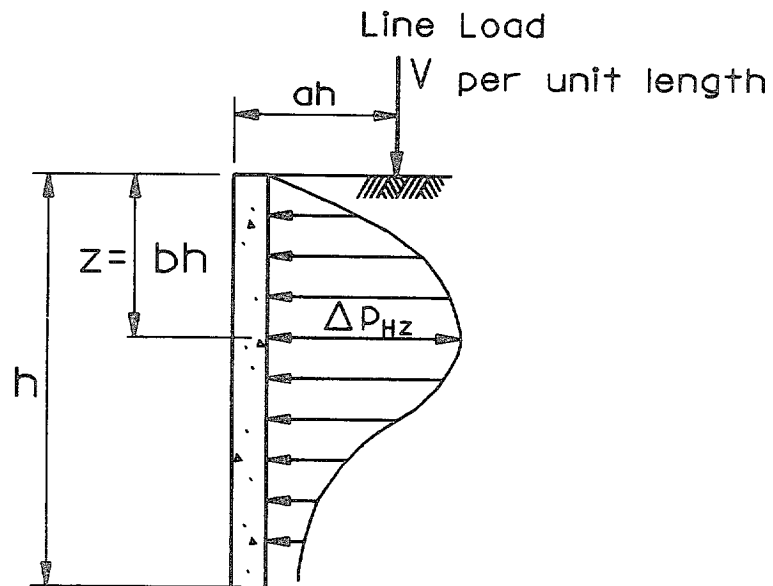

Increase in horizontal pressure, ΔP_{Hz} , at depth bh due to line load, V/ft at distance ah from wall.

$$\Delta P_{Hz} = \left(\frac{4V}{\pi h} \right) \left(\frac{a^2 b}{(a^2 + b^2)^2} \right) \quad \text{for } a > 0.4$$

$$\Delta P_{Hz} = \left(\frac{V}{h} \right) \left(\frac{0.203 b}{(0.16 + b^2)^2} \right) \quad \text{for } a \leq 0.4$$

Figure 3-26. Increase in pressure due to line load (after Spangler 1956)

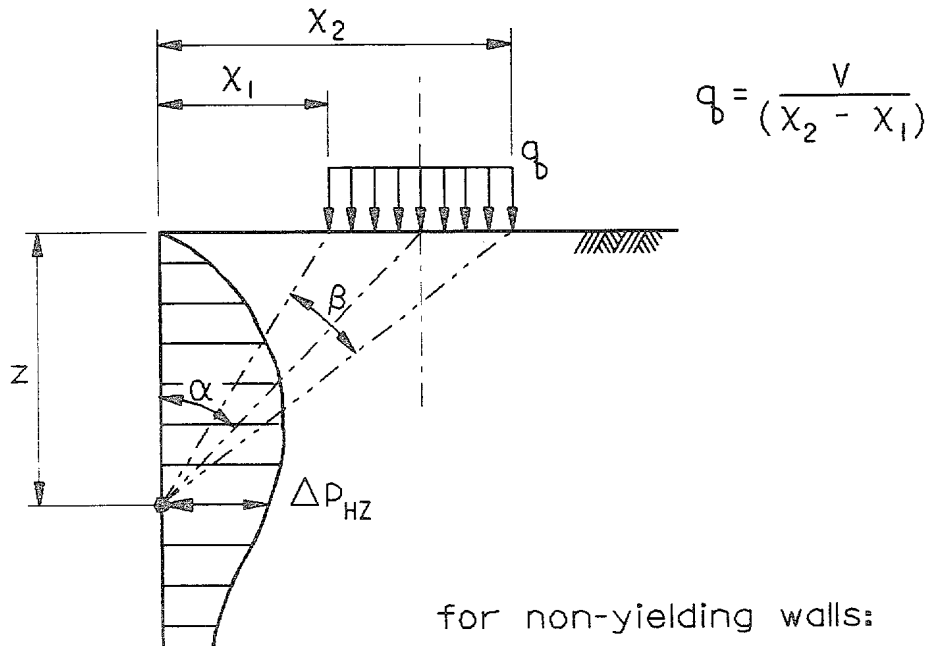

for non-yielding walls:

$$\Delta P_{HZ} = \frac{2q_b}{\pi} (\beta - \sin \beta \cos 2\alpha)$$

for yielding walls,
(walls at failure):

$$\Delta P_{HZ} = \frac{q_b}{\pi} (\beta - \sin \beta \cos 2\alpha)$$

β in radians

$$\beta = \tan^{-1} \left(\frac{x_2}{z} \right) - \tan^{-1} \left(\frac{x_1}{z} \right)$$

$$\alpha = \tan^{-1} \left(\frac{x_2 + x_1}{2z} \right)$$

Figure 3-27. Increase in pressure due to strip load

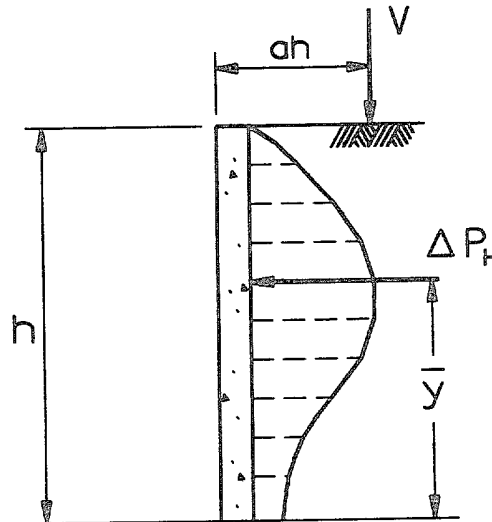

Point Load, V

a	ΔP_H	\bar{y}
0.4	0.78 (V/h)	.59 h
0.5	0.60 (V/h)	.54 h
0.6	0.46 (V/h)	.48 h

Line Load, V/ft

for $a \leq 0.4$ $\Delta P_H = 0.55 V$

for $a > 0.4$ $\Delta P_H = \frac{0.64 V}{(a^2 + 1)}$

a	\bar{y}
0.4	0.60 h
0.5	0.56 h
0.6	0.52 h
0.7	0.48 h

Figure 3-28. Resultant forces, point and line loads (after Spangler 1956)

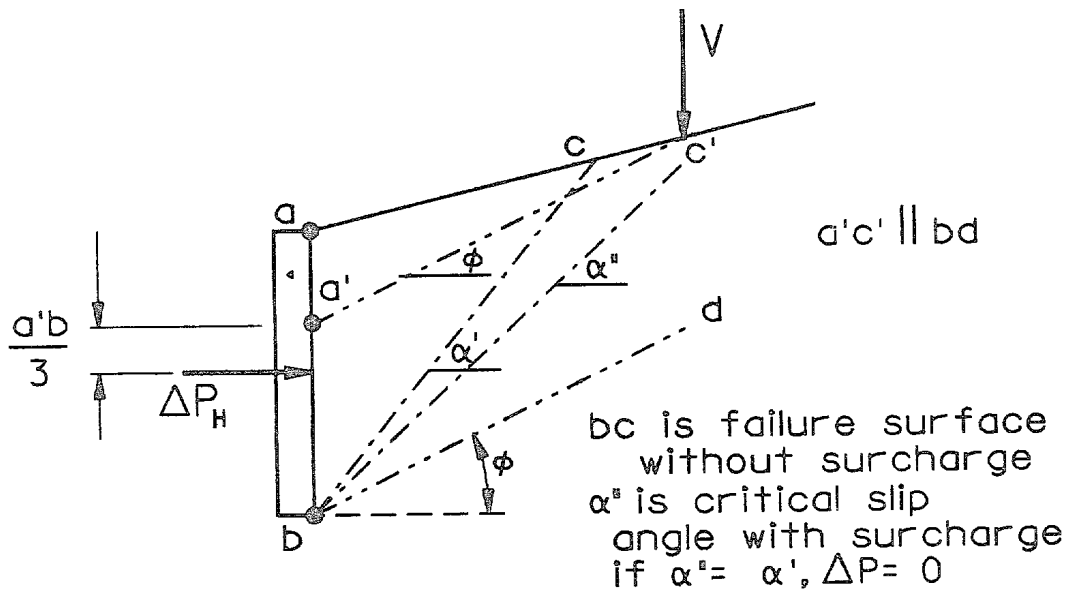
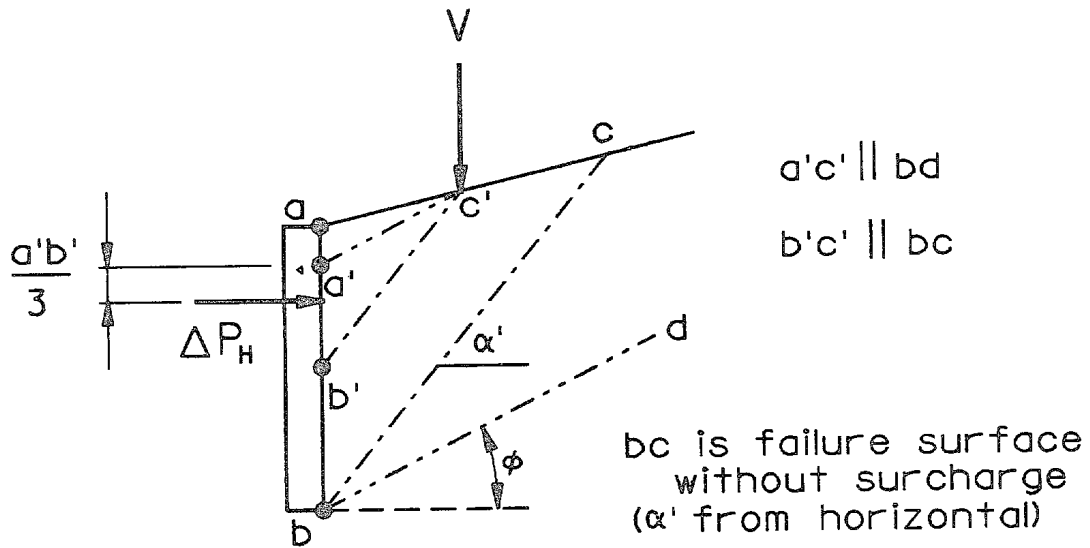

$$\Delta P_H = P (\gamma_s V) - P (\gamma)$$

Figure 3-29. Approximate line of action for line loads (Terzaghi 1943)

for walls designed for at-rest conditions. The roller is assumed to exert a line load of P lb/ft obtained from the roller weight and drum dimensions; double this value is recommended for vibratory rollers. The design pressure diagram (Figure 3-30) is composed of three linear segments:

a. Starting at the top of the wall, the pressure increases linearly to a value of p'_{hm} at a depth z_{cr} . In this region, the horizontal stress is increased during compaction due to the roller pressure but then the horizontal stress is reduced by passive failure when the roller is removed.

b. The horizontal pressure is constant with depth from z_{cr} to z_2 and is compaction induced.

c. At depth z_2 , the compaction-induced pressure equals the horizontal pressure due to soil weight (at-rest pressure). The pressure increases linearly below this depth according to the equations in paragraph 3-15.

Compaction-induced pressures need only be considered for structural design. For overturning, bearing, and sliding analyses, any wall movement due to compaction-induced pressures would be accompanied by a reduction in the pressure. As shown by the calculations in Appendix J, horizontal pressures due to compaction may exceed the at-rest pressure in only the upper few feet unless roller loads are particularly high. The effects of compaction are shown in example 1 of Appendix M.

Section III. Water Pressures

3-18. Pressure Calculations. In all cases, water pressures at a point may be calculated by multiplying the pressure head at the point by the unit weight of water (62.4 lb/cu ft). As water has no shear strength, water pressures are equal in all directions ($K = 1.0$). The pressure head is equal to the total head minus the elevation head. The pressure head at a point is the height water would rise in a piezometer placed at the point. The elevation head is the height of the point itself above an arbitrary datum. Water pressures must be added to effective earth pressures to obtain total pressures.

a. Static Pressures. For static water (no seepage) above or below the ground surface, the total head is constant and the pressure head at any point is the difference in elevation between the water surface and the point.

b. Water Pressures with Earth Pressure Equations. Where Coulomb or at-rest equations are used to calculate the driving-side earth pressures for a totally submerged soil mass, the buoyant soil weight ($\gamma' = \gamma_{sat} - \gamma_w$) is used in the earth pressure equations and the calculated effective earth pressures are added to the calculated water pressures.

c. Water Forces with Wedge Analysis. The wedge method (Equations 3-23 and 3-33) uses total densities, uplift forces, and horizontal water forces on

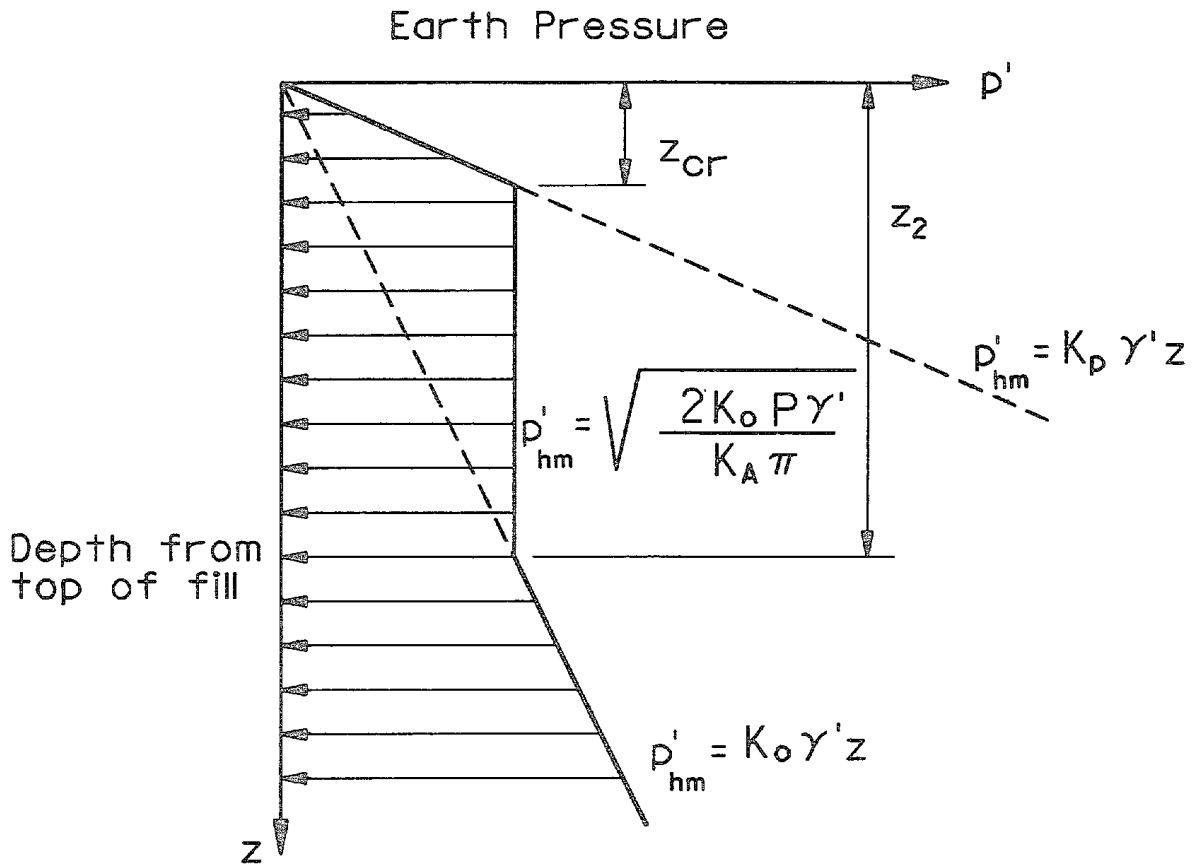

$$z_{cr} = \sqrt{\frac{2K_A K_o P}{\pi \gamma}}$$

$$z_2 = \sqrt{\frac{2P}{K_A K_o \pi \gamma'}}$$

P is roller line load, lb/ft (use twice roller weight for vibratory rollers)

Figure 3-30. Design pressure envelope for nonyielding walls with compaction effects

the vertical sides of the wedge. Consequently, it gives the effective earth force, and water forces must be added to obtain total forces (see example 3 in Appendix M).

d. Water Pressures Where Seepage is Present. Where seepage occurs, the pressure head at points of interest must be obtained from a seepage analysis. Such an analysis must consider the types of foundation and backfill materials, their possible range of horizontal and vertical permeabilities, and the effectiveness of drains. Techniques of seepage analysis are discussed in EM 1110-2-1901, Casagrande (1937), Cedergren (1967), Harr (1962), and other references. Techniques applicable to wall design include flow nets and numerical methods such as the finite element method and the method of fragments. An example of pressure calculations using a flow net is shown in Figure 3-31. Where soil conditions adjacent to and below a wall can be assumed homogeneous (or can be mathematically transformed into equivalent homogeneous conditions) simplified methods such as the line-of-creep method may be used. Simplified methods are advantageous for preliminary studies to size wall elements or compare alternate wall designs; however, designers should ensure that the final design incorporates water pressures based on appropriate consideration of actual soil conditions.

3-19. Seepage Analysis by Line-of-Creep Method. Where soil conditions can be assumed homogeneous, the line-of-creep (or line-of-seepage) method provides a reasonable approximate method for estimating uplift pressures that is particularly useful for preliminary or comparative designs. The line of creep may underestimate uplift pressures on the base and thus be unconservative. Therefore, final design should be based on a more rigorous analysis. The method is illustrated in Figure 3-32. The total heads at the ends of the base (points B and C) are estimated by assuming that the total head varies linearly along the shortest possible seepage path (A'BCD'). Once the total head at B and C is known, the uplift pressures U_B and U_C are calculated by subtracting the elevation head from the total head at each point and multiplying the resulting pressure head by the unit weight of water. The total uplift diagram along the failure surface is completed in a similar manner. Where a key is present (Figure 3-33), point B is at the bottom of the key and line segment BC is drawn diagonally. Examples using the line-of-creep method are contained in Appendix N.

3-20. Seepage Analysis by Method of Fragments. Another approximate method applicable to homogeneous soil conditions is the method of fragments. It is more accurate than the line-of-creep method. The soil is divided into a number of regions or fragments for which exact solutions of the seepage conditions exist. The head loss through each fragment is calculated by mathematically combining the assemblage of fragments. The method assumes that fragment boundaries are equipotential lines (contours of equal total head) and provides an exact solution where this assumption is true (I-walls and single sheet piles). Details of the method and instructions for the computer program CFRAG (Appendix O) are presented by Pace, et al. (1984). Further background on the method is presented by Harr (1962, 1977). Keyed bases should be modeled by treating the key as a sheet pile and the soil below the base as a

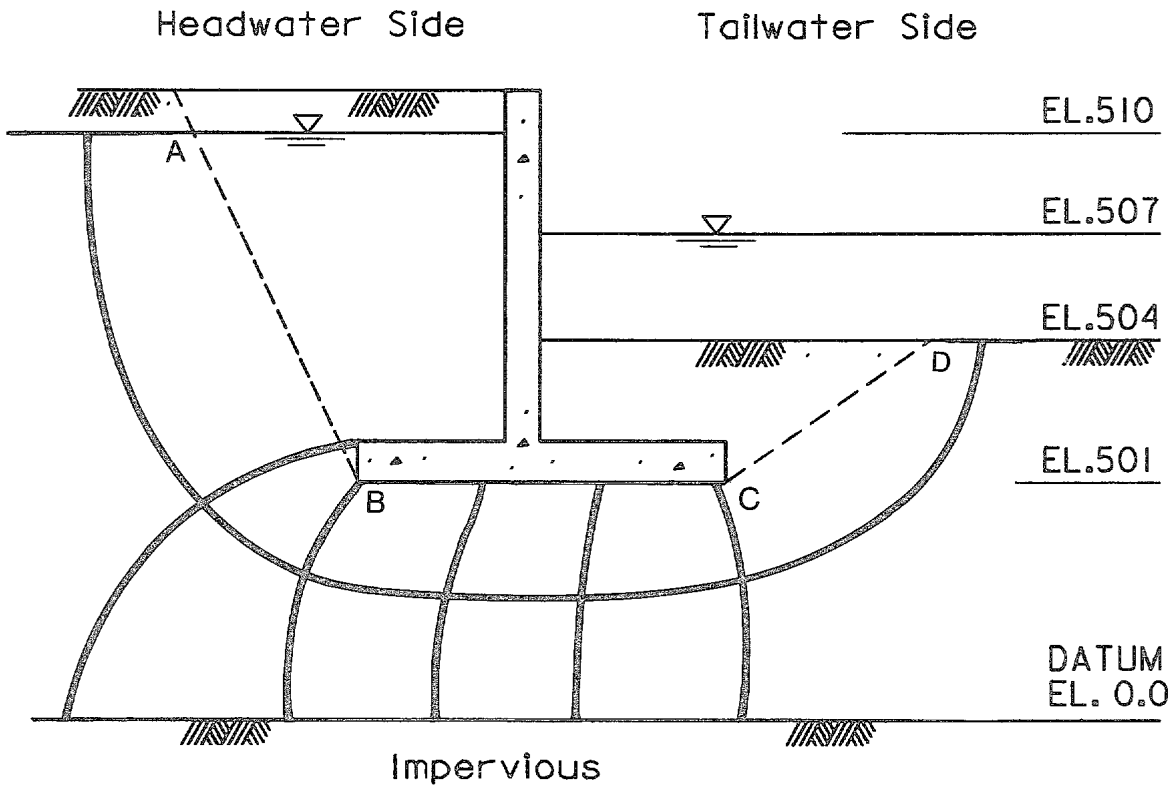

Pt. A Total Head: 510
Elevation Head: 510
Pressure Head: 0
Pressure: 0

Pt. B Total Head: $510 - (2/6)(510 - 507) = 509$
 $507 + (4/6)(3) = 509$

Elevation Head: 501
Pressure Head: $509 - 501 = 8'$

Pressure: $(8)(62.4) = 499.2 \text{ lb/ft}^2$

Figure 3-31. Water pressures from flow net

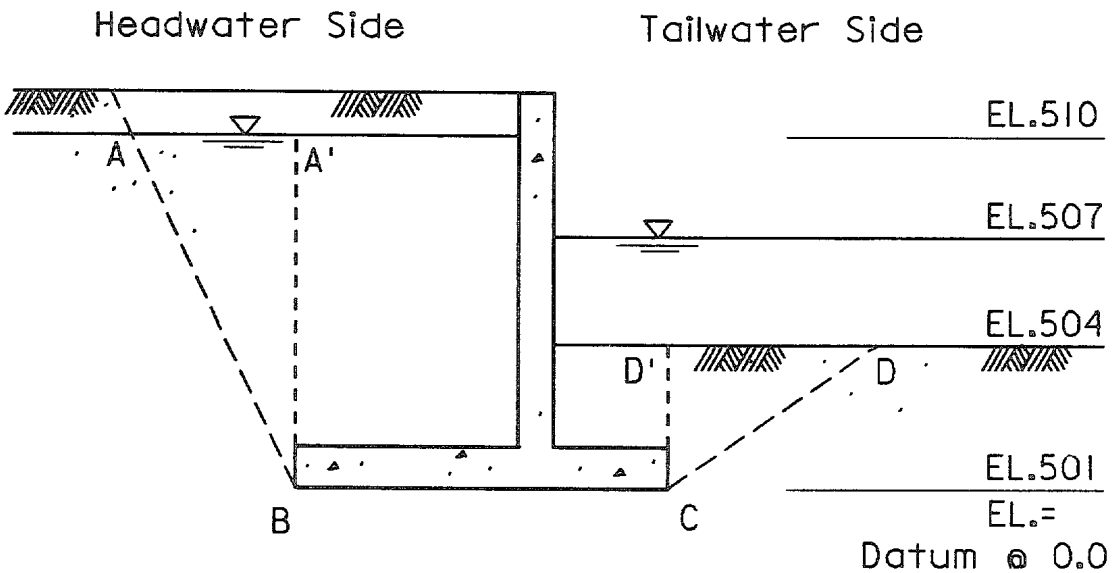

Length of Shortest Seepage Path: A'BCD'

(A') Total Head at A': 510 ft.
Elevation Head at A': 510 ft.
Pressure Head at A': 0 ft.

(B) Total Head at B: $510 - \left[\frac{(A'B)}{(A'BCD')} \right] (510 - 507)$

Elevation Head at B: 501
Pressure Head at B = Total Head - Elevation Head

(C) Total Head at C: $510 - \left[\frac{(A'BC)}{(A'BCD')} \right] (510 - 507)$

Elevation Head at C: 501
etc.

Water Pressure: $P_w = \gamma_w \cdot (\text{Pressure Head})$

Figure 3-32. Water pressure by line-of-creep method

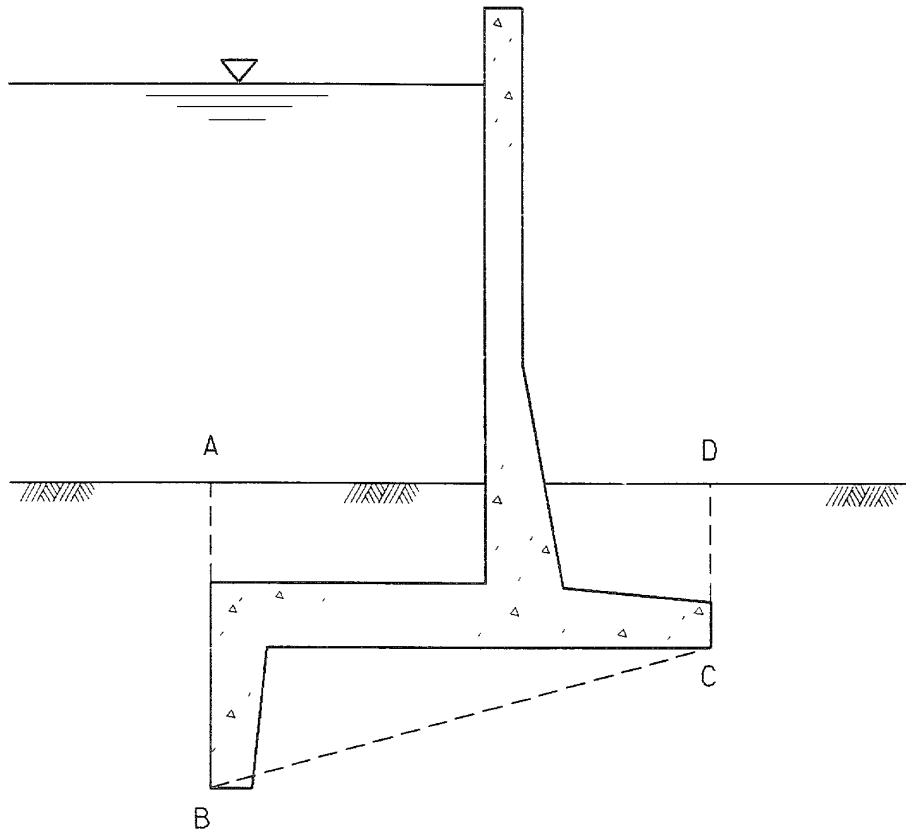

Figure 3-33. Seepage path for line of creep

type IV. Accuracy is improved by minimizing the number of fragments, not by maximizing them to incorporate minor changes in geometry. Where water pressure on the base of a wall is calculated by the method of fragments, the water pressure along the driving-side and resisting-side wedge bases may be taken to vary linearly as described in the preceding paragraph.

3-21. Seepage Analysis by the Finite Element Method. The finite element method provides a powerful tool to solve confined or unconfined seepage problems involving multiple soils with isotropic or anisotropic permeabilities. It is particularly useful for evaluating the effect of drains and analyzing walls with complicated foundation and backfill geometry. The WES computer program for the finite element method is described by Tracy (1983). Pre- and post-processors for the program are also available (Tracy 1977a, 1977b).

3-22. Uplift Calculations for Rock Foundations. Seepage beneath flood walls

founded on competent rock typically occurs in joints and fractures, not uniformly through pores as assumed for soils. Consequently, the assumptions of isotropy and homogeneity and the use of two-dimensional analysis models commonly employed for soil foundations will generally be invalid. Total head, uplift pressure, and seepage quantities may be highly dependent on the type, size, orientation, and continuity of joints and fractures in the rock and the type and degree of treatment afforded the rock foundation during construction. Since any joints or fractures in the rock can be detrimental to underseepage control, the joints and fractures should be cleaned out and filled with grout before the concrete is placed, as discussed in paragraph 7-4g. For walls on a rock foundation, the total seepage path can be assumed to be the length of the base which is in compression. An example of a wall on a rock foundation is shown in example 2 of Appendix N.

3-23. Effect of Drains. Water pressures for design analyses should consider both working drains and blocked drainage conditions. Achieving an adequate factor of safety for an analysis considering blocked drainage is usually not good justification for omitting drains. Preferred practice is to provide drains; lower factors of safety than specified herein may be justified where blocked drainage assumptions are combined with rare and/or conservative loading assumptions. All such deviations from recommended safety factors should be supported by an assessment of expected drain reliability, and a justification that the factor of safety is reasonable in light of the analyzed conditions. Drains are discussed further in paragraphs 6-6 and 7-4.

3-24. Surge and Wave Loads.

a. General Criteria. Wave and water level predictions for the analysis of walls should be determined with the criteria presented in the Shore Protection Manual (U. S. Army Engineer Waterways Experiment Station 1984). Design forces acting on the wall should be determined for the water levels and waves predicted for the most severe fetch and the effects of shoaling, refraction, and diffraction. A distinction is made between the action of nonbreaking, breaking, and broken waves, where the methods recommended for calculation of wave forces are for vertical walls. Wave forces on other types of walls (i.e., sloping, stepped, curved, etc.) are not sufficiently understood to recommend general analytical design criteria. In any event, a coastal engineer should be involved in establishing wave forces for the design of important structures.

b. Wave Heights. Wave heights for design are obtained from the statistical distribution of all waves in a wave train, and are defined as follows:

H_s = average of the highest one-third of all waves

H_1 = $1.67 H_s$ = average of highest 1 percent of all waves

H_b = height of wave which breaks in water depth d_b

c. Nonbreaking Wave Condition. When the depth of water is such that

29 Sep 89

waves do not break, a nonbreaking condition exists. This occurs when the water depth at the wall is greater than approximately 1.5 times the maximum wave height. The H_1 wave shall be used for the nonbreaking condition.

Design nonbreaking wave pressures shall be computed using the Miche-Rudgren Method, as described in Chapter 7 of the Shore Protection Manual (U. S. Army Engineer Waterways Experiment Station 1984). Whenever the maximum stillwater level results in a nonbreaking condition, lower stillwater levels should be investigated for the possibility that shallow water may produce breaking wave forces which are larger than the nonbreaking forces.

d. Breaking Wave Condition. The breaking condition occurs when the steepness of the wave and the bottom slope on the front of the wall have certain relationships to each other. It is commonly assumed that a structure positioned in a water depth d_s will be subject to the breaking wave condition if $d_s \leq 1.3 H$ where H is the design wave height. Study of the breaking process indicates that this assumption is not always valid. The height of the breaking wave and its breaking point are difficult to determine, but breaker height can be equal to the water depth of the structure, depending on bottom slope and wave period. Detailed determination of breaker heights and distances for a sloping approach grade in front of the wall are given in the Shore Protection Manual (U. S. Army Engineer Waterways Experiment Station 1984). Special consideration must be given to a situation where the fetch shoals abruptly (as with a bulkhead wall submerged by a surge tide) near the wall, but at a distance more than an approximate 0.7 wavelength away from the wall, and then maintains a constant water depth from that point to the wall. In this case waves larger than the water depth can be expected to have broken at the abrupt shoaling point, leaving smaller, higher frequency waves to reach the wall. Design breaking wave pressure should be determined by the Minikin method presented in Chapter 7 of the Shore Protection Manual (U. S. Army Engineer Waterways Experiment Station 1984). Breaking wave impact pressures occur at the instant the vertical force of the wave hits the wall and only when a plunging wave entraps a cushion of air against the wall. Because of this dependence on curve geometry, high impact pressures are infrequent against prototype structures; however, they must be recognized and considered in design. Also, since the high impact pressures caused by breaking waves are of high frequency, their importance in design against sliding and overturning may be questionable relative to longer lasting lower dynamic forces. An example involving a breaking wave condition is shown in example 7 of Appendix N.

e. Broken Wave Condition. Broken waves are those that break before reaching the wall but near enough to have retained some of the forward momentum of breaking. The design breaker height in this case (H_b) is the highest wave that will be broken in the break zone. Design wave forces for the height H_b should be determined by the method presented in Chapter 7 of the Shore Protection Manual (U. S. Army Engineer Waterways Experiment Station 1984).

f. Seepage Pressures. Seepage pressures are based on the elevation of the surge stillwater level (paragraph 4-5).

Section IV. Supplemental Forces

3-25. Wind Load. Wind loads should be considered for retaining and flood walls during construction, prior to placing backfill. Wind loads can act any time in the life of a flood wall. In locations subjected to hurricanes, a wind load of 50 lb/sq ft can be used conservatively for walls 20 feet or less in height for winds up to 100 miles per hour (mph). In locations not subjected to hurricanes, 30 lb/sq ft can be used conservatively for the same height of wall and wind velocity conditions. For more severe conditions, the wind loads should be computed in accordance with ANSI A58.1 using a coefficient C_f equal to 1.2.

3-26. Earthquake Forces.

a. General. For retaining walls which are able to yield laterally during an earthquake, the calculation of increased earth pressures induced by earthquakes can be approximated by the Mononobe-Okabe pseudo-static approach outlined below. In addition, the inertial forces of the wall, plus that portion of the adjacent earth and/or water which is assumed to act with the wall, should be included.

b. Mononobe-Okabe Analysis. This analysis is an extension of the Coulomb sliding-wedge theory taking into account horizontal and vertical inertial forces acting on the soil. The analysis is described in detail by Seed and Whitman (1970) and Whitman and Liao (1985).

(1) Assumptions. The following assumptions are made by the Mononobe-Okabe analysis:

(a) The wall is free to yield sufficiently to enable full soil strength or active pressure conditions to be mobilized.

(b) The backfill is completely above or completely below the water table, unless the top surface is horizontal, in which case the backfill can be partially saturated.

(c) The backfill is cohesionless.

(d) The top surface is planar (not irregular or broken).

(e) Any surcharge is uniform and covers the entire surface of the soil wedge.

(f) Liquefaction is not a problem.

(2) Equations. Equilibrium considerations of the soil wedge on the driving and resisting sides lead to the following Mononobe-Okabe equations for computing the active and passive forces exerted by the soil on the wall when the soil mass is at the point of failure (total shear resistance mobilized) along the slip plane of the Mononobe-Okabe wedge shown in Figure 3-34:

For driving (active) wedges (Figure 3-34a),

$$P_{AE} = \frac{1}{2} K_{AE} \gamma (1 - k_v) h^2 \quad [3-44]$$

$$K_{AE} = \frac{\cos^2 (\phi - \Psi - \theta)}{\cos \Psi \cos^2 \theta \cos (\Psi + \theta + \delta) \left[1 + \sqrt{\frac{\sin (\phi + \delta) \sin (\phi - \Psi - \beta)}{\cos (\beta - \theta) \cos (\Psi + \theta + \delta)}} \right]^2} \quad [3-45]$$

For resisting (passive) wedges (Figure 3-34b),

$$P_{PE} = \frac{1}{2} K_{PE} \gamma (1 - k_v) h^2 \quad [3-46]$$

$$K_{PE} = \frac{\cos^2 (\phi - \Psi + \theta)}{\cos \Psi \cos^2 \theta \cos (\Psi - \theta + \delta) \left[1 - \sqrt{\frac{\sin (\phi + \delta) \sin (\phi - \Psi + \beta)}{\cos (\beta - \theta) \cos (\Psi - \theta + \delta)}} \right]^2} \quad [3-47]$$

P_{AE} and P_{PE} are the combined static and dynamic forces due to the driving and resisting wedges, respectively. The equations are subject to the same limitations that are applicable to Coulomb's equations. Definitions of terms are as follows:

γ = unit weight of soil

k_v = vertical acceleration in g's

h = height of wall

ϕ = internal friction angle of soil

$\Psi = \tan \left(\frac{k_h}{1 - k_v} \right)$ = seismic inertia angle

k_h = horizontal acceleration in g's

θ = inclination of wall with respect to vertical (this definition of θ is different from θ in Coulomb's equations)

δ = wall friction angle

β = inclination of soil surface (upward slopes away from the wall are positive)

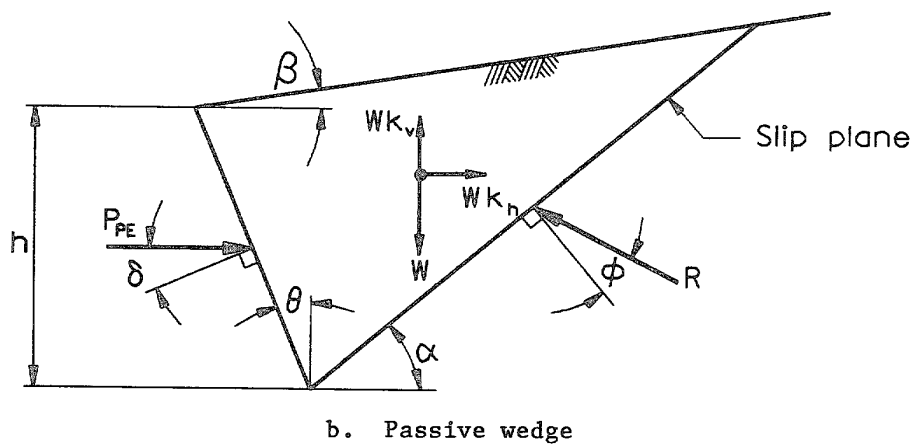
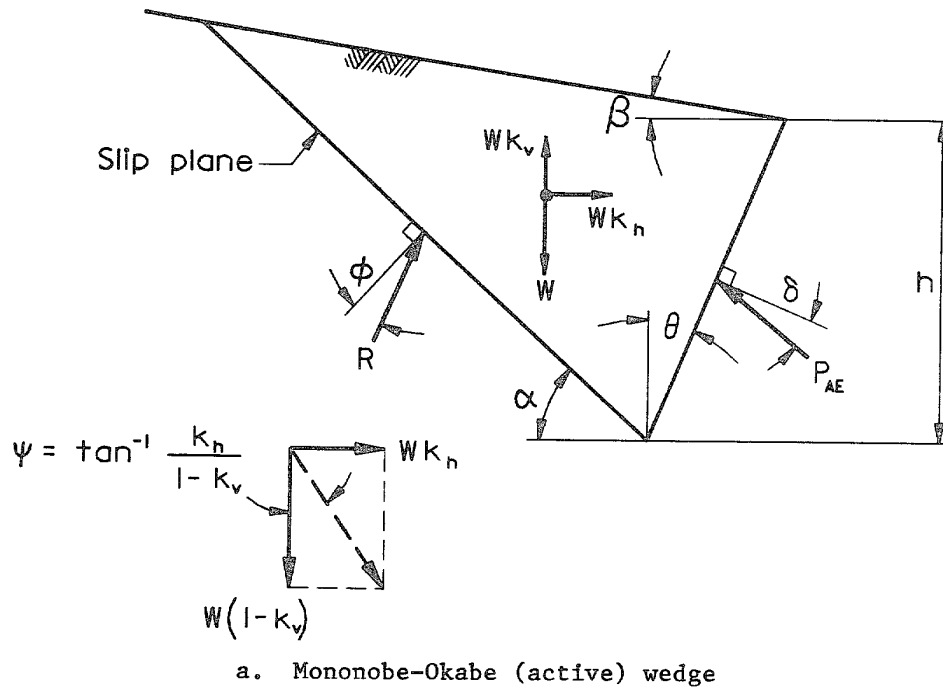

Figure 3-34. Driving and resisting seismic wedges, no saturation

(3) Simplifying Conditions. For the usual case where k_v , δ , and θ are taken to be zero, the equations reduce to:

$$K_{AE} = \frac{\cos^2 (\phi - \Psi)}{\cos^2 \Psi \left[1 + \sqrt{\frac{\sin \phi \sin (\phi - \Psi - \beta)}{\cos \beta \cos \Psi}} \right]^2} \quad [3-48]$$

$$K_{PE} = \frac{\cos^2 (\phi - \Psi)}{\cos^2 \Psi \left[1 - \sqrt{\frac{\sin \phi \sin (\phi - \Psi + \beta)}{\cos \beta \cos \Psi}} \right]^2} \quad [3-49]$$

where

$$\Psi = \tan^{-1} (k_h)$$

and

$$P_{AE} = 1/2 K_{AE} \gamma h^2$$

$$P_{PE} = 1/2 K_{PE} \gamma h^2$$

For the case when the water table is above the backfill, P_{AE} and P_{PE} must be divided into static and dynamic components for computing the lateral forces. Buoyant soil weight is used for computing the static component below the water table, with the hydrostatic force added, and saturated soil weight is used for computing the dynamic component (see paragraph 3-26c(3)).

(4) Observations. General observations from using Mononobe-Okabe analysis are as follows:

(a) As the seismic inertia angle Ψ increases, the values of K_{AE} and K_{PE} approach each other and, for a vertical backfill face ($\theta = 0$), become equal when $\Psi = \phi$.

(b) The locations of P_{AE} and P_{PE} are not given by the Mononobe-Okabe analysis. Seed and Whitman (1970) suggest that the dynamic component ΔP_{AE} be placed at the upper one-third point, ΔP_{AE} being the difference between P_{AE} and the total active force from Coulomb's active wedge without the earthquake. The general wedge earthquake analysis described in paragraph 3-26c places the dynamic component ΔP_{AE} at the upper one-third point also, but computes ΔP_{AE} as being the difference between P_{AE} and the total active

force from the Mononobe-Okabe wedge. The latter method for computing ΔP_{AE} , which uses the same wedge for computing the static and dynamic components of P_{AE} , is preferred.

(c) Another limitation of the Mononobe-Okabe equation is that the contents of the radical in the equation must be positive for a real solution to be possible, and for this it is necessary that $\phi \geq \Psi + \beta$ for the driving wedges and $\phi \geq \Psi - \beta$ for the resisting wedges. This condition could also be thought of as specifying a limit to the horizontal acceleration coefficient that could be sustained by any structure in a given soil. The limiting condition for the driving wedge is:

$$k_h \leq (1 - k_v) \tan (\phi - \beta) \quad [3-50]$$

and for the resisting wedge:

$$k_h \leq (1 - k_v) \tan (\phi + \beta) \quad [3-51]$$

(d) Figure 3-35a (Applied Technology Council 1981) shows the effect on the magnification factor F_T (equal to K_{AE}/K_A) on changes in the vertical acceleration coefficient k_v . Positive values of k_v have a significant effect for values of k_v greater than 0.2. The effect is greater than 10 percent above and to the right of the dashed line. For values of k_h of 0.2 or less, k_v can be neglected for all practical purposes.

(e) K_{AE} and F_T are also sensitive to variations in backfill slope, particularly for higher values of horizontal acceleration. This effect is shown in Figure 3-35b.

c. General Wedge Earthquake Analysis. When the Coulomb wedge assumptions cannot be met, the following wedge analysis can be used. The equations for the dynamic force given below for various conditions are simply the horizontal acceleration coefficient multiplied by the weight of the wedge defined by the critical slip-plane angle. See example 11 of Appendix M for sample calculations.

(1) Assumptions. The equations for determining the critical slip-plane angle for driving and resisting wedges subjected to a horizontal acceleration are developed with the following assumptions:

(a) The shear on the vertical face of the wedge is zero.

(b) The shear strength along the potential slip planes in the soil has not been mobilized to any extent, i.e., for static loading prior to an earthquake.

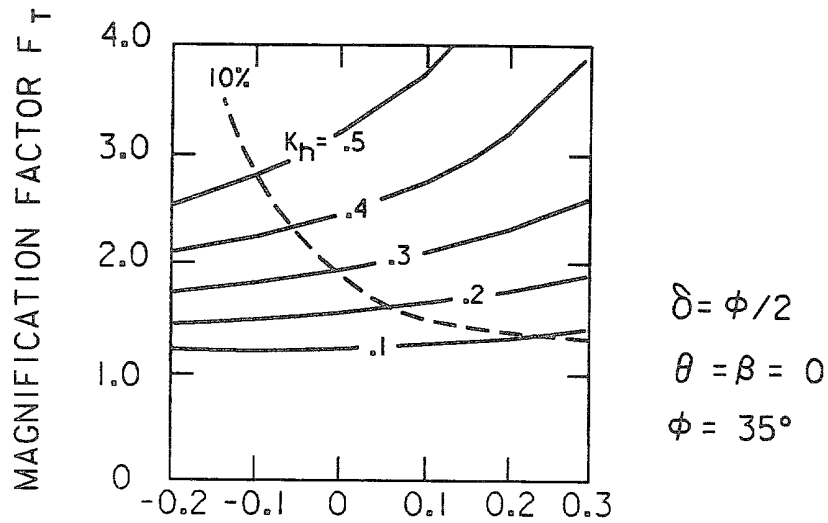

VERTICAL SEISMIC COEFFICIENT k_v

a. Influence of vertical seismic coefficient on magnification factor

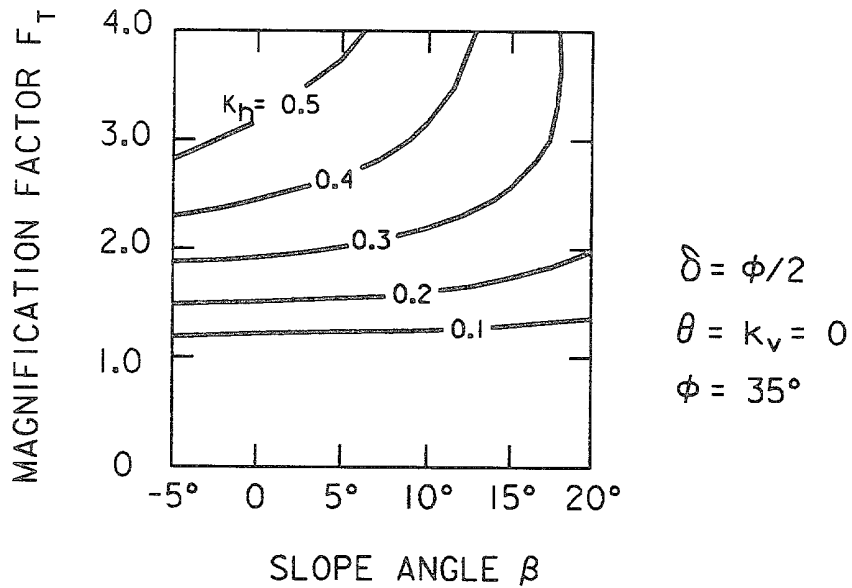

b. Influence of backfill slope angle on magnification factor

Figure 3-35. Influence of k_v and β on magnification factor
 (after Applied Technology Council 1981)

(2) Equations for Cohesionless, Dry Backfill Above the Water Table. Driving and resisting forces for cohesionless, dry, sloping planar-surfaced backfill below the water table where k_v , δ , and $\theta = 0$ can be computed as follows:

(a) Static Components. The static components for a driving and resisting wedge are:

$$P_A = \frac{1}{2} K_A \gamma h^2 \quad [3-52]$$

$$P_P = \frac{1}{2} K_P \gamma h^2 \quad [3-53]$$

where

$$K_A = \left(\frac{1 - \tan \phi \cot \alpha}{1 + \tan \phi \tan \alpha} \right) \left(\frac{\tan \alpha}{\tan \alpha - \tan \beta} \right) \quad [3-54]$$

$$K_P = \left(\frac{1 + \tan \phi \cot \alpha}{1 - \tan \phi \tan \alpha} \right) \left(\frac{\tan \alpha}{\tan \alpha - \tan \beta} \right) \quad [3-55]$$

as derived in paragraph H-2 and H-3, Appendix H.

For an active wedge:

$$\alpha = \tan^{-1} \left(\frac{c_1 + \sqrt{c_1^2 + 4c_2}}{2} \right) \quad [3-56]$$

$$c_1 = \frac{2 (\tan \phi - k_h)}{1 + k_h \tan \phi} \quad [3-57]$$

$$c_2 = \frac{\tan \phi (1 - \tan \phi \tan \beta) - (\tan \beta + k_h)}{\tan \phi (1 + k_h \tan \phi)} \quad [3-58]$$

For a passive wedge:

$$\alpha = \tan^{-1} \left(\frac{-c_1 + \sqrt{c_1^2 + 4c_2}}{2} \right) \quad [3-59]$$

$$c_1 = \frac{2 (\tan \phi - k_h)}{1 + k_h \tan \phi} \quad [3-60]$$

$$c_2 = \frac{\tan \phi (1 + \tan \phi \tan \beta) + (\tan \beta - k_h)}{\tan \phi (1 + k_h \tan \phi)} \quad [3-61]$$

If $k_v > 0$, replace γ with $(1 - k_v)\gamma$.

(b) Dynamic Components. The dynamic component for each wedge is:

$$\Delta P_{AE} = \Delta P_{PE} = k_h \left[\frac{\gamma h^2}{2 (\tan \alpha - \tan \beta)} \right] \quad [3-62]$$

(c) Total Driving Force. The total driving force is:

$$P_{AE} = P_A + \Delta P_{AE} \quad [3-63]$$

which is equal to:

$$P_{AE} = \frac{1}{2} K_{AE} \gamma h^2 \quad [3-64]$$

from the Mononobe-Okabe analysis.

The line of action for P_{AE} may be found as:

$$Y_{AE} = \frac{P_A \left(\frac{h}{3} \right) + \Delta P_{AE} \left(\frac{2h}{3} \right)}{P_{AE}} \quad [3-65]$$

It should be noted that for large values of k_h , which cause α to be small,

P_A can be negative causing the line of action of P_{AE} to lie above the upper third point.

(d) Total Resisting Force. The total resisting force is:

$$P_{PE} = P_P - \Delta P_{PE} \quad [3-66]$$

which is equal to:

$$P_{PE} = \frac{1}{2} K_{PE} \gamma h^2 \quad [3-67]$$

from the Mononobe-Okabe analysis.

The line of action for P_{PE} may be found as:

$$Y_{PE} = \frac{P_P \left(\frac{h}{3}\right) - \Delta P_{PE} \left(\frac{2h}{3}\right)}{P_{PE}} \quad [3-68]$$

(3) Equations for Cohesionless Backfill with Water Table. Driving and resisting forces for cohesionless, sloping, planar-surfaced backfill with water table where k_v , δ , and $\theta = 0$ can be computed as follows:

(a) Driving Force. The static components for a driving wedge are (see Figures 3-36a and 3-37a):

$$P_A = P_{A1} + P_{A2} = \frac{1}{2} K_A \gamma (h - h_s)^2 + \frac{1}{2} h_s \left[2K_A \gamma (h - h_s) + K_b \gamma_b h_s \right] \quad [3-69]$$

$$P_{ws} = \frac{1}{2} \gamma_w h_s^2 \quad [3-70]$$

and the dynamic components are (see Figures 3-36a and 3-37a):

$$\Delta P_{AE} = \Delta P_{AE1} + \Delta P_{AE2} = k_h \left[\frac{\gamma h^2}{2(\tan \alpha - \tan \beta)} \right] + k_h \left[\frac{(\gamma_s - \gamma) h_s^2}{2 \tan \alpha} \right] \quad [3-71]$$

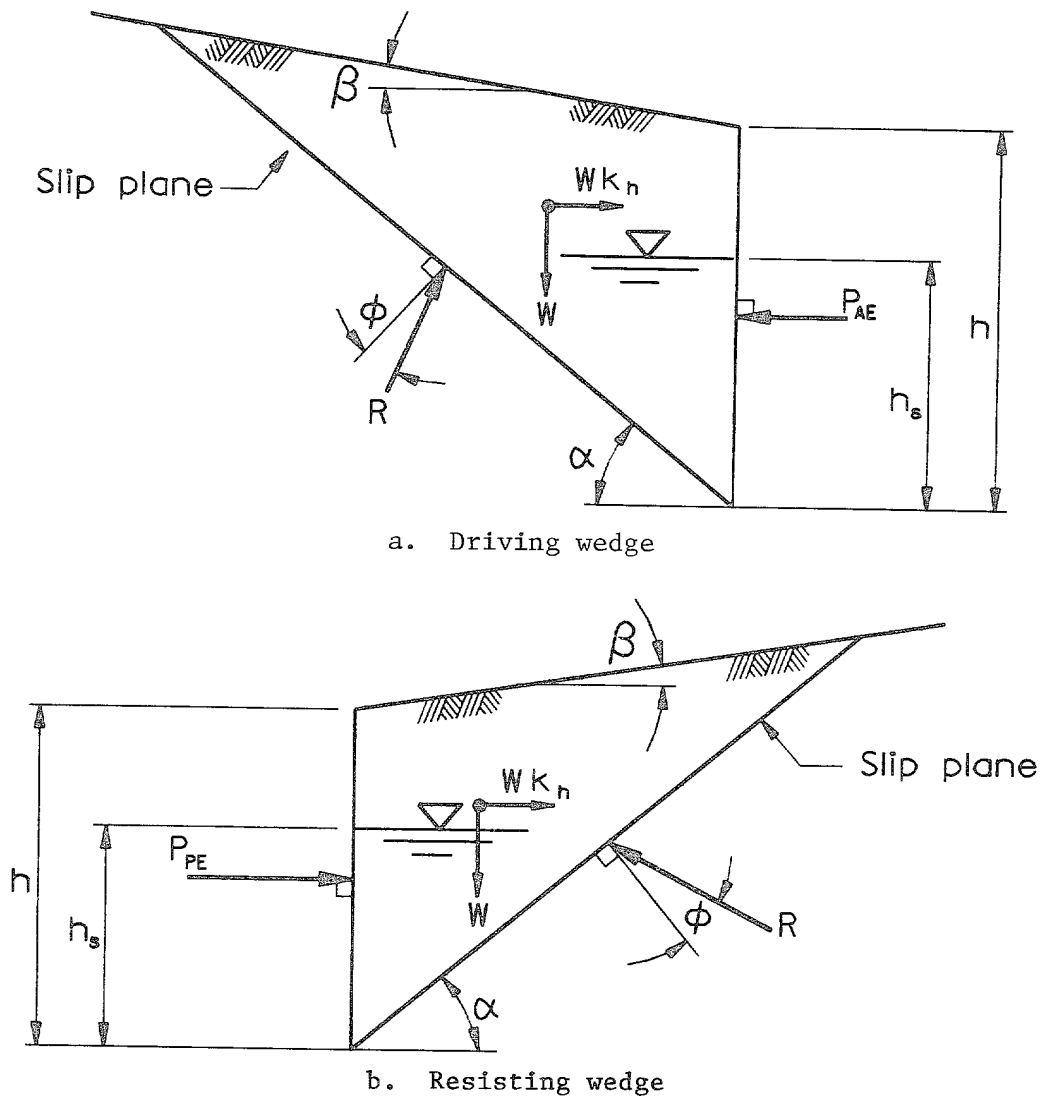
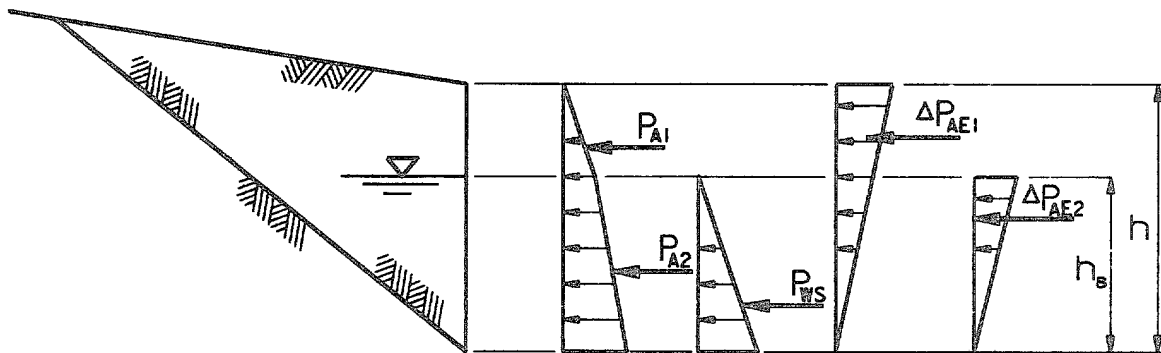
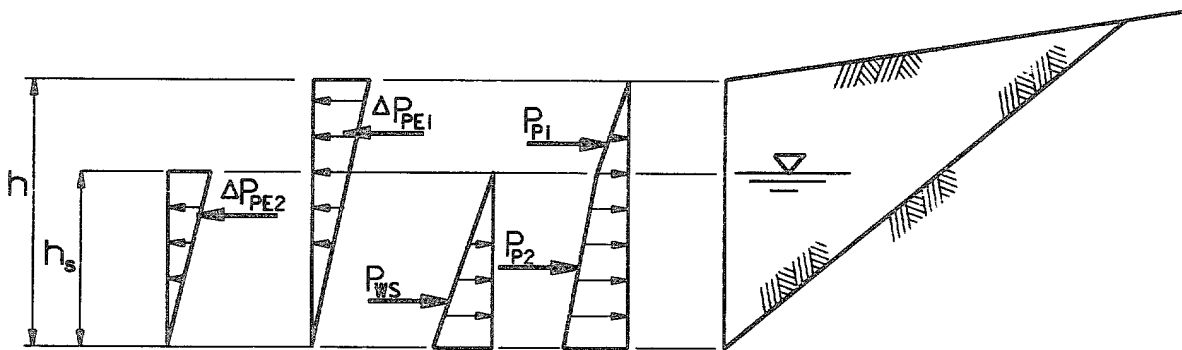

Figure 3-36. Seismic wedges, water table within wedge



a. Driving wedge



b. Resisting wedge

Figure 3-37. Static and dynamic pressure diagrams, water table within wedge

giving a total force of:

$$P_{AE} = P_A + P_{ws} + \Delta P_{AE} \quad [3-72]$$

where

γ_s = saturated unit weight of fill

γ = moist unit weight of fill

γ_b = buoyant unit weight of fill

γ_w = unit weight of water

$$K_A = \left(\frac{1 - \tan \phi \cot \alpha}{1 + \tan \phi \tan \alpha} \right) \left(\frac{\tan \alpha}{\tan \alpha - \tan \beta} \right)$$

$$K_b = \left(\frac{1 - \tan \phi \cot \alpha}{1 + \tan \phi \tan \alpha} \right) \left[1 + \left(\frac{\tan \alpha}{\tan \alpha - \tan \beta} - 1 \right) \frac{\gamma}{\gamma_b} \right]$$

and α is defined in Equation 3-56.

(b) Resisting Force. The static components for the resisting wedge are (see Figures 3-36b and 3-37b):

$$P_P = P_{P1} + P_{P2} = \frac{1}{2} K_P \gamma (h - h_s)^2 + \frac{1}{2} h_s \left[2K_P \gamma (h - h_s) + K_b \gamma_b h_s \right] \quad [3-73]$$

$$P_{ws} = \frac{1}{2} \gamma_w h_s^2 \quad [3-74]$$

and the dynamic components are:

$$\Delta P_{PE} = \Delta P_{PE1} + \Delta P_{PE2} = k_h \left[\frac{\gamma h^2}{2 (\tan \alpha - \tan \beta)} \right] + k_h \left[\frac{(\gamma_s - \gamma) h_s^2}{2 \tan \alpha} \right] \quad [3-75]$$

giving a total force of:

$$P_{PE} = P_P + P_{ws} - \Delta P_{PE} \quad [3-76]$$

where γ , γ_b , γ_s , and γ_w are defined in paragraph 3-26c(3)(a),
and

$$K_P = \left(\frac{1 + \tan \phi \cot \alpha}{1 - \tan \phi \tan \alpha} \right) \left(\frac{\tan \alpha}{\tan \alpha - \tan \beta} \right) \quad [3-77]$$

$$K_b = \left(\frac{1 + \tan \phi \cot \alpha}{1 - \tan \phi \tan \alpha} \right) \left[1 + \frac{\tan \alpha}{\tan \alpha - \tan \beta} - 1 \frac{\gamma}{\gamma_b} \right] \quad [3-78]$$

and the equations for α are given in Equation 3-59.

(4) Equations for Cohesive Backfill with Water Table. Driving and resisting forces for a cohesive, sloping, planar-surfaced backfill with water table where k_v , δ , and $\theta = 0$ can be computed as follows:

(a) Driving Force. The static components for the driving wedge are (see Figure 3-38a):

$$P_A = P_{A1} + P_{A2} = \frac{1}{2} K_A \gamma \left[(h - d_c) - h_s \right]^2 + \frac{1}{2} h_s \left[2K_A \gamma (h - d_c - h_s) + K_b \gamma_b h_s \right] \quad [7-79]$$

$$P_{ws} = \frac{1}{2} \gamma_w h_s^2 \quad [7-80]$$

and the dynamic components are (see Figure 3-38a):

$$\Delta P_{AE} = \Delta P_{AE1} + \Delta P_{AE2} = k_h \left[\frac{\gamma (h^2 - d_c^2)}{2 (\tan \alpha - \tan \beta)} \right] + k_h \left[\frac{(\gamma_s - \gamma)^2 h_s^2}{2 \tan \alpha} \right] \quad [3-81]$$

giving a total force of:

$$P_{AE} = P_A + P_{ws} + \Delta P_{AE} \quad [3-82]$$

29 Sep 89

where

 γ = moist unit weight of fill γ_b = buoyant unit weight of fill γ_s = saturated unit weight of fill γ_w = unit weight of water

$$K_A = \left(\frac{1 - \tan \phi \cot \alpha}{1 + \tan \phi \tan \alpha} \right) \left(\frac{\tan \alpha}{\tan \alpha - \tan \beta} \right) \quad [3-83]$$

$$K_b = \left(\frac{1 - \tan \phi \cot \alpha}{1 + \tan \phi \tan \alpha} \right) \left[1 + \left(\frac{\tan \alpha}{\tan \alpha - \tan \beta} - 1 \right) \frac{\gamma}{\gamma_b} \right] \quad [3-84]$$

$$\alpha = \tan^{-1} \left(\frac{c_1 + \sqrt{c_1^2 + 4c_2}}{2} \right) \quad [3-85]$$

$$c_1 = \frac{2 \tan \phi (\tan \phi - k_h) + \frac{4c (\tan \phi + \tan \beta)}{\gamma(h + d_c)}}{A} \quad [3-86]$$

$$c_2 = \frac{\tan \phi (1 - \tan \phi \tan \beta) - (\tan \beta + k_h) + \frac{2c(1 - \tan \phi \tan \beta)}{\gamma(h + d_c)}}{A} \quad [3-87]$$

$$A = (1 + k_h \tan \phi) \tan \phi + \frac{2c(1 - \tan \phi \tan \beta)}{\gamma(h + d_c)} \quad [3-88]$$

$$d_c = \frac{c/\gamma}{\cos \alpha (\sin \alpha - \tan \phi \cos \alpha)} \quad [3-89]$$

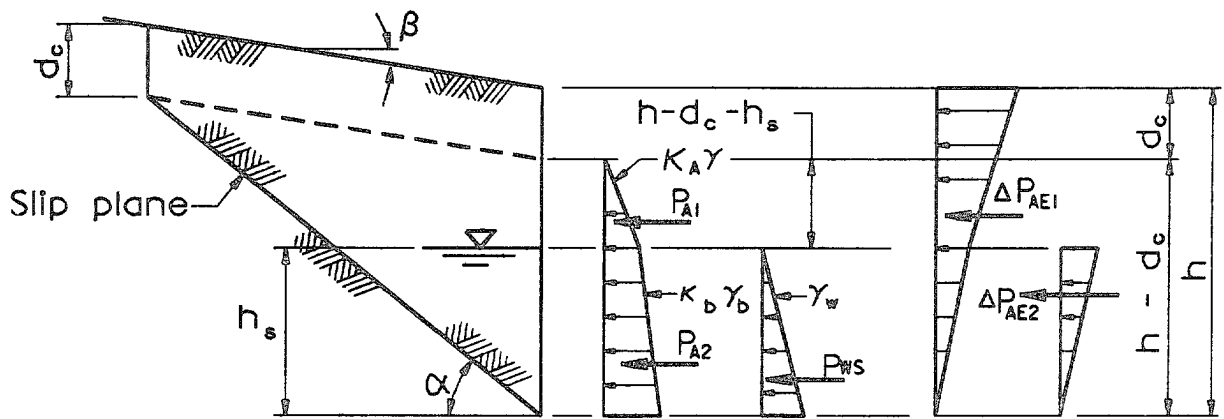

a. Driving wedge

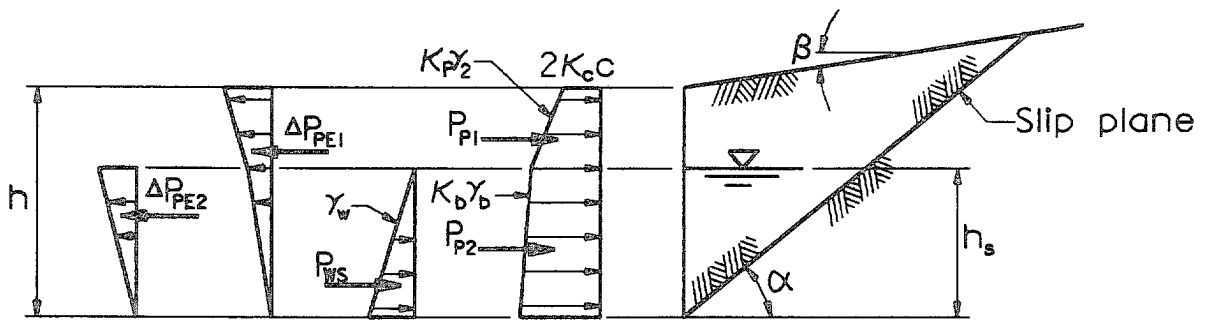

b. Resisting wedge

Figure 3-38. Static and dynamic pressure diagrams, cohesive fill, water table within wedge

(b) Resisting Force. The static components for the resisting wedge are (Figure 3-38b):

$$P_P = P_{P1} + P_{P2} = \frac{1}{2} K_P \gamma (h - h_s)^2 + \frac{1}{2} h_s \left[2K_P \gamma (h - h_s) + K_b \gamma_b h_s \right] + 2K_c ch \quad [3-90]$$

$$P_{ws} = \frac{1}{2} \gamma_w h_s^2 \quad [3-91]$$

and the dynamic components are (see Figure 3-38b):

$$\Delta P_{PE} = \Delta P_{PE1} + \Delta P_{PE2} = k_h \left[\frac{\gamma h^2}{2 (\tan \alpha - \tan \beta)} \right] + k_h \left[\frac{(\gamma_s - \gamma) h_s^2}{2 \tan \alpha} \right] \quad [3-92]$$

giving a total force of:

$$P_{PE} = P_P + P_{ws} + \Delta P_{PE} \quad [3-93]$$

where γ , γ_b , γ_s , and γ_w are defined in paragraph 3-26c(4)(a).

and

$$K_P = \left(\frac{1 + \tan \phi \cot \alpha}{1 - \tan \phi \tan \alpha} \right) \left(\frac{\tan \alpha}{\tan \alpha - \tan \beta} \right) \quad [3-94]$$

$$K_b = \left(\frac{1 + \tan \phi \cot \alpha}{1 - \tan \phi \tan \alpha} \right) \left[1 + \left(\frac{\tan \alpha}{\tan \alpha - \tan \beta} - 1 \right) \frac{\gamma}{\gamma_b} \right] \quad [3-95]$$

$$\alpha = \tan^{-1} \left(\frac{-c_1 + \sqrt{c_1^2 + 4c_2}}{2} \right) \quad [3-96]$$

$$c_1 = \frac{2 \tan \phi (\tan \phi - k_h) + \frac{4c (\tan \phi - \tan \beta)}{\gamma h}}{A} \quad [3-97]$$

$$c_2 = \frac{\tan \phi(1 + \tan \phi \tan \beta) + (\tan \beta - k_h) + \frac{2c(1 + \tan \phi \tan \beta)}{\gamma h}}{A} \quad [3-98]$$

$$A = (1 + k_h \tan \phi) \tan \phi + \frac{2c(1 + \tan \phi \tan \beta)}{\gamma h} \quad [3-99]$$

$$K_c = \frac{1}{2 \sin \alpha \cos \alpha (1 - \tan \phi \cos \alpha)} \cdot \frac{\tan \alpha}{\tan \alpha - \tan \beta} \quad [3-100]$$

d. Inertia Force of Wall. The inertia force of the wall, including that portion of the backfill above the heel or toe of the wall and any water within the backfill which is not included as part of the Coulomb wedge, is computed by multiplying the selected acceleration coefficient by the weight of the wall and backfill. This force is obtained by multiplying the mass by acceleration as follows:

$$F = ma = ma \left(\frac{g}{g} \right) = \frac{a}{g} w = k_h W \quad [3-101]$$

e. Hydrodynamic Force Due to Water Above Ground Level. Water standing above ground can have its static pressure, acting against a wall, increased or decreased due to seismic action. Figure 3-39 shows the pressures and forces due to earthquakes for freestanding water. The dynamic force is given by Westergaard's (1933) equation as:

$$P_E = \left(\frac{2}{3} \right) C_E k_h h^2 \quad [3-102]$$

where C_E is a factor depending upon the depth of water, h , in feet, and the earthquake period of vibration, T , in seconds. Westergaard's approximate equation for C_E in kip-second-foot units is:

$$C_E = \frac{0.051}{\sqrt{1 - 0.72 (h/1000T)^2}} \quad [3-103]$$

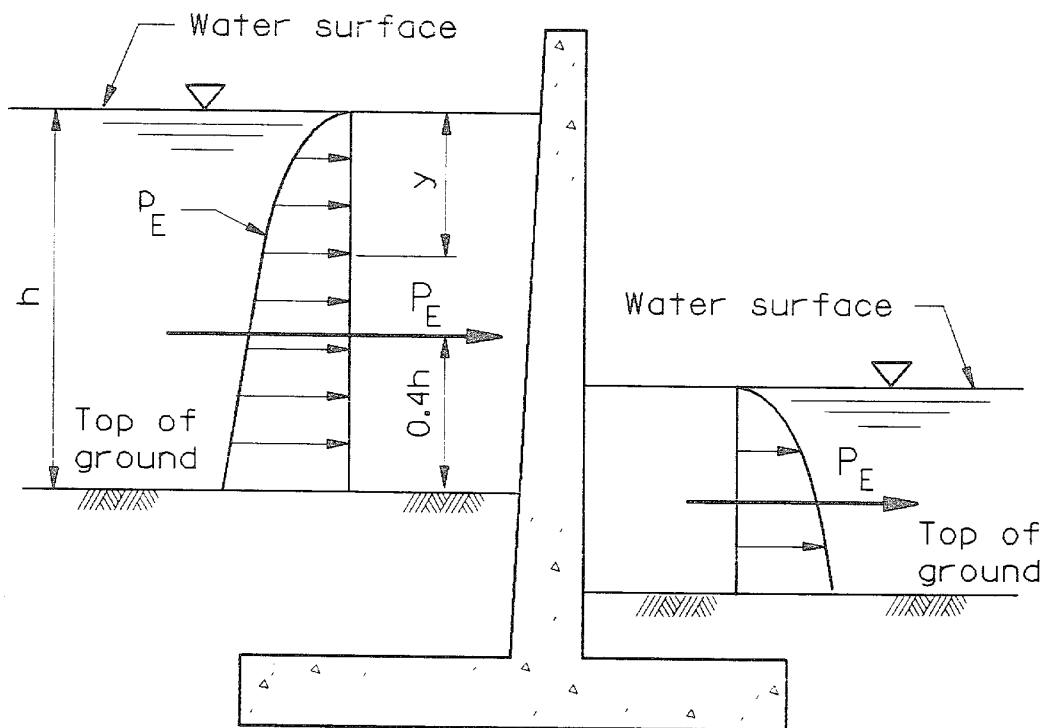

Figure 3-39. Hydrodynamic forces for freestanding water

Normally, for retaining and flood walls, C_E can be taken as 0.051. The pressure distribution is parabolic, and the pressure at any point y below the top surface is:

$$p_E = C_E k_h \sqrt{hy} \quad [3-104]$$

The line of action of force P_E is $0.4h$ above the ground surface.

f. Selection of Acceleration Coefficients.

(1) Minimum Acceleration Coefficients. Minimum horizontal acceleration coefficient values for the United States and its Territories are listed in ER 1110-2-1806. In the absence of more accurate data, these values can be used as a guide for determining the acceleration coefficient to be used in the calculation of lateral earthquake forces on retaining and flood walls. As discussed in paragraph 3-26b(3)(d) where the horizontal ground acceleration is $0.2 g$ or less, the vertical ground acceleration can be neglected for all

practical purposes. When the vertical acceleration coefficient is included in the analysis, it is normally taken as two-thirds of the horizontal acceleration coefficient.

(2) Acceleration Coefficients Greater than 0.2. When the design acceleration coefficient exceeds 0.2, the Mononobe-Okabe analysis may require the size of the wall to be excessively great. To provide a more economical structure, design for a small tolerable lateral displacement rather than no lateral displacement may be preferable (Applied Technology Council 1981). A method for computing the magnitude of relative wall displacement during a given earthquake is described by Whitman and Liao (1985).

(3) Acceleration Coefficients for Walls Forming Part of a Dam. For retaining walls forming part of a dam, where failure of the wall would jeopardize the safety of the dam, the selection of the acceleration coefficients for the design of the wall should be consistent with those used for the stability analyses and concrete design of the dam, where required (ER 1110-2-1806).

CHAPTER 4

STRUCTURE STABILITY

4-1. Scope. This chapter presents information for stability analysis of retaining walls and inland and coastal flood walls. The methods of analysis to determine overturning and sliding stability and to assess bearing capacity are discussed. The forces as determined in Chapter 3 are used to assess overturning stability and bearing capacity. In certain cases as described in this chapter, the same forces computed for overturning may be used to check sliding stability. In other cases, sliding stability should be computed by the multiple wedge iterative method or by an adjustment of the driving and resisting wedge forces based on the factor of safety required, both of which are discussed in this chapter. Loading conditions for the various types of walls and the acceptable criteria for each loading condition are given for each of the stability analyses.

Section I. Loading Conditions

4-2. Representative Loading Conditions. The following loading conditions are generally representative of conditions affecting retaining walls and inland and coastal flood walls. The loading cases for a specific wall should be chosen, as applicable, from the lists below. Loading conditions which are not listed below should be analyzed, where applicable. Note that some walls may require consideration of loadings from both lists, as discussed in paragraph 2-9.

4-3. Retaining Walls.

a. Case R1, Usual Loading. The backfill is in place to the final elevation; surcharge loading, if present, is applied (stability should be checked with and without the surcharge); the backfill is dry, moist, or partially saturated as the case may be; any existing lateral and uplift pressures due to water are applied. This case also includes the usual loads possible during construction which are not considered short-duration loads.

b. Case R2, Unusual Loading. This case is the same as Case R1 except the water table level in the backfill rises, for a short duration, or another type of loading of short duration is applied; e.g., high wind loads (paragraph 3-25), equipment surcharges during construction, etc.

c. Case R3, Earthquake Loading. This is the same as Case R1 with the addition of earthquake-induced lateral and vertical loads, if applicable; the uplift is the same as for Case R1.

4-4. Inland Flood Walls.

a. Case I1, Design Flood Loading. The backfill is in place to the final

elevation; the water level is at the design flood level (top of wall less freeboard) on the unprotected side; uplift is acting.

b. Case I2, Water to Top of Wall. This is the same as Case I1 except the water level is at the top of the unprotected side of the wall.

c. Case I3, Earthquake Loading. The backfill is in place to the final elevation; the water is at the usual level during the non-flood stage; uplift, if applicable, is acting; earthquake-induced lateral and vertical loads, if applicable, are acting. (Note: This case is necessary only if the wall has a significant loading during the non-flood stage.)

d. Case I4, Construction Short-Duration Loading. The flood wall is in place with the loads added which are possible during the construction period, but are of short duration such as from strong winds (paragraph 3-25) and construction equipment surcharges.

4-5. Coastal Flood Walls.

a. Case C1, Surge Stillwater Loading. The backfill is in place to the final elevation; the water is at the surge stillwater level on the unprotected side; wave forces are excluded; uplift is acting.

b. Case C2a, Nonbreaking Wave Loading. This is the same as Case C1 with a nonbreaking wave loading added, if applicable; uplift is the same as for Case C1.

c. Case C2b, Breaking Wave Loading. This is the same as Case C1 with a breaking wave loading added, if applicable; uplift is the same as for Case C1.

d. Case C2c, Broken Wave Loading. This is the same as Case C1 with a broken wave loading added, if applicable; uplift is the same as for Case C1.

e. Case C3, Earthquake Loading. The backfill is in place to the final elevation; water is at the usual (non-storm) level; uplift, if applicable, is acting; earthquake-induced lateral and vertical loads, if applicable, are acting. (Note: If the wall has no significant load during the usual (non-storm) stage, no earthquake case is necessary.)

f. Case C4, Construction Short-Duration Loading. The flood wall is in place with the loads added which are possible during the construction period but are of short duration, such as from strong winds and construction equipment surcharges.

g. Case C5, Wind Loading. The backfill is in place to the final elevation; water is at the usual (non-storm) level on the unprotected side; a wind load of 50 lb/sq ft on the protected side of the wall is applied (paragraph 3-25).

Section II. Stability Considerations

4-6. General Requirements. Figure 4-1 illustrates the potential failure modes for which stability must be analyzed. The basic requirements for the stability of a retaining or flood wall for all loading conditions are discussed below.

a. The wall should be safe against sliding at its base, through any soil layer or rock seam below the base.

b. The wall should be safe against overturning at its base, and, in the case of gravity walls, at any horizontal plane within the wall.

c. The wall should be safe against bearing failure and excessive differential settlement in the foundation.

4-7. Stability Criteria. The stability criteria for retaining walls and inland and coastal flood walls are listed, by loading case, in Tables 4-1 through 4-3.

Section III. Overturning Stability

4-8. Resultant Location.

a. General Computations. To assess the overturning stability of a wall, such as the one with a horizontal base shown in Figure 4-2 (see examples 1, 2, 3, 5, 6, and 7 of Appendix N), all operative forces must be applied to a free body of the structural wedge wall/soil system. Methods to calculate the lateral and uplift forces are discussed in Chapter 3. The moments of these forces are summed about point O as shown in Figure 4-2 and the distance x_R is calculated as:

$$x_R = \frac{\text{summation of moments about Point O}}{\Sigma V} \quad [4-1]$$

where

ΣV = resultant base force required for vertical equilibrium

A ratio defined as the resultant ratio is computed as follows:

$$\text{Resultant ratio} = \frac{x_R}{\text{horizontal width of base}} \quad [4-2]$$

Equations 4-1 and 4-2 are valid for a wall with a horizontal base with or without a key and for a wall with a sloped base and a key. If a wall has only a sloped base (no key), as shown in Figure 4-3 (see example 4 of Appendix N), x_R is calculated as:

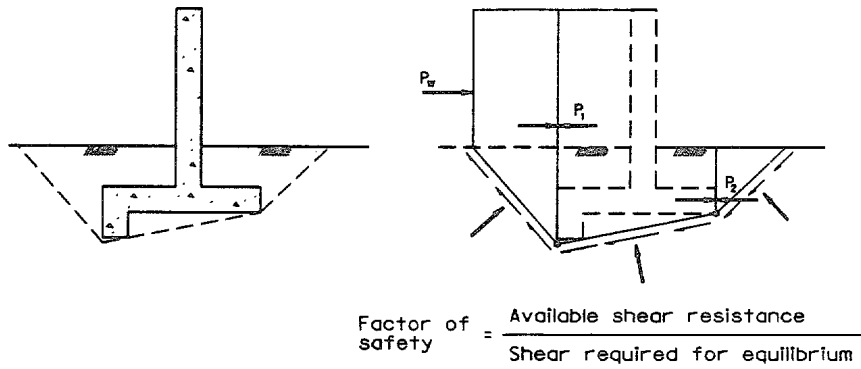

a. Sliding

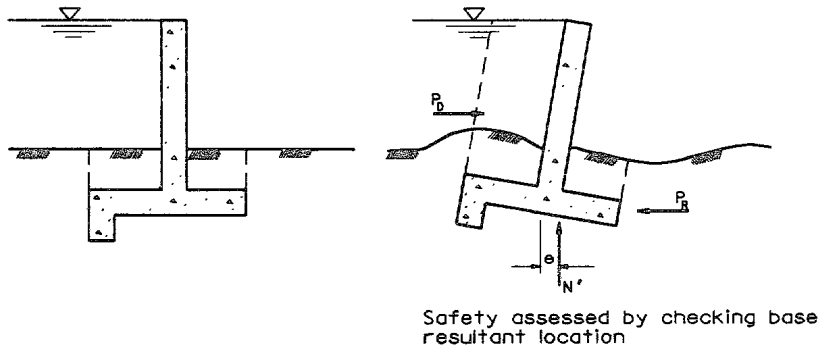

b. Overturning

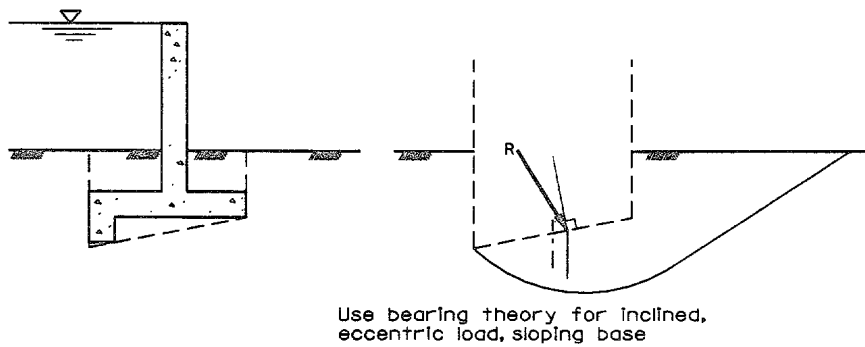

c. Bearing

Figure 4-1. Stability considerations for retaining and flood walls

Table 4-1
Retaining Wall Stability Criteria

Case No.	Loading Condition	Sliding Factor of Safety, FS	Shear Strength Test Required		Overturing Criteria		Minimum Bearing Capacity Safety Factor
			Soil Foundation	Rock Foundation ³	Minimum Base Area in Compression	Minimum Base Rock Foundation	
R1	Usual	1.5	(Q &/or S) ^{2,1}	Direct shear	100% ⁴	75% ⁴	3.0
R2	Unusual	1.33	(Q &/or S) ^{2,1}	Direct shear	75% ⁴	50% ⁴	2.0
R3	Earthquake	1.1	(Q)	Direct shear	Resultant within base	Resultant within base	>1.0

Notes

- For soil foundations which are not free draining (permeability $< 10 \times 10^{-4}$ cm/sec), analyze for both Q and S strengths and design for the worst condition. For free-draining soil foundations (permeability $> 10 \times 10^{-4}$ cm/sec), analyze for S strengths only.
- For construction loadings in Cases R1 and R2, use Q strengths when excess pore water pressure in the soil foundation is anticipated and S strengths when it is not anticipated.
- The sliding analysis of a wall on rock should be based on the frictional resistance ($\tan \phi$) of concrete on rock or rock on rock. The values should be obtained from direct shear tests of pre-cut samples of concrete on rock and rock on rock, or direct shear tests of natural rock joints or bedding planes.
- Less base area in compression than the minimum shown may be acceptable provided adequate safety against unacceptable differential settlement and bearing failure is obtained.

Table 4-2
Inland Flood Wall Stability Criteria

Case No.	Loading Condition	Sliding Factor of Safety, FS	Shear Strength Test Required		Overturning Criteria		Minimum Bearing Capacity	Safety Factor
			Soil Foundation	Rock Foundation ³	Area in Compression Soil Foundation	Area in Compression Rock Foundation		
I1	Design flood	1.5	(Q &/or S) ¹	Direct shear	100% ⁴	75% ⁴	3.0	
I2	Water to top of wall	1.33	(Q &/or S) ¹	Direct shear	75% ⁴	50% ⁴	2.0	
I3	Earthquake	1.1	(Q)	Direct shear	Resultant within base	Resultant within base	>1.0	
I4	Construction	1.33	(Q &/or S) ²	Direct shear	75% ⁴	50% ⁴	2.0	

Notes

- For soil foundations which are not free draining (permeability $< 10 \times 10^{-4}$ cm/sec), analyze for both Q and S strengths and design for the worst condition. For free-draining soil foundations (permeability $> 10 \times 10^{-4}$ cm/sec), analyze for S strengths only.
- For construction loading cases, use Q strengths when excess pore water pressure in the soil foundation is anticipated and S strengths when it is not anticipated.
- The sliding analysis of a wall on rock should be based on the frictional resistance ($\tan \phi$) of concrete on rock or rock on rock. The values should be obtained from direct shear tests of pre-cut samples of concrete on rock and rock on rock, or direct shear tests of natural rock joints or bedding planes.
- Less base area in compression than the minimum shown may be acceptable provided adequate safety against unacceptable differential settlement and bearing failure is obtained.

Table 4-3
Coastal Flood Wall Stability Criteria

Case No.	Loading Condition	Sliding Factor of Safety, FS	Shear Strength Test Required		Overturning Criteria			Minimum Bearing Capacity Safety Factor
			Soil Foundation	Rock Foundation ³	Area in Compression	Soil Foundation	Rock Foundation	
C1	Surge stillwater	1.5	(Q &/or S) ¹	Direct shear	100% ⁵	75% ⁵	3.0	
C2	Wave							
C2a	Nonbreaking	1.33	(Q &/or S) ¹	Direct shear	75% ⁵	50% ⁵	2.0	
C2b	Breaking	1.25	(Q) ⁴	Direct shear	60% ⁵	40% ⁵	1.5	
C2c	Broken	1.33	(Q) ⁴	Direct shear	75% ⁵	50% ⁵	2.0	
C3	Earthquake	1.1	(Q)	Direct shear	Resultant within base	Resultant within base	>1.0	
C4	Construction	1.33	(Q &/or S) ²	Direct shear	75% ⁵	50% ⁵	2.0	
C5	Wind	1.33	(Q &/or S) ²	Direct shear	75% ⁵	50% ⁵	2.0	

Notes

- For soil foundations which are not free draining (permeability $< 10 \times 10^{-4}$ cm/sec), analyze for both Q and S strengths and design for the worst condition. For free-draining soil foundations (permeability $> 10 \times 10^{-4}$ cm/sec), analyze for S strengths only.
- For construction loading cases, use Q strengths when excess pore water pressure in the soil foundation is anticipated and S strengths when it is not anticipated.
- The sliding analysis of a wall on rock should be based on the frictional resistance ($\tan \phi$) of concrete on rock or rock on rock. The values should be obtained from direct shear tests of pre-cut samples of concrete on rock and rock on rock, or direct shear tests of natural rock joints or bedding planes.
- For soil foundations which are not free draining (permeability $< 10 \times 10^{-4}$ cm/sec), analyze for Q test. For free draining soil foundations (permeability $\geq 10 \times 10^{-4}$ cm/sec), analyze for S strengths.
- Less base area in compression than the minimum shown may be acceptable provided adequate safety against unacceptable differential settlement and bearing failure is obtained.

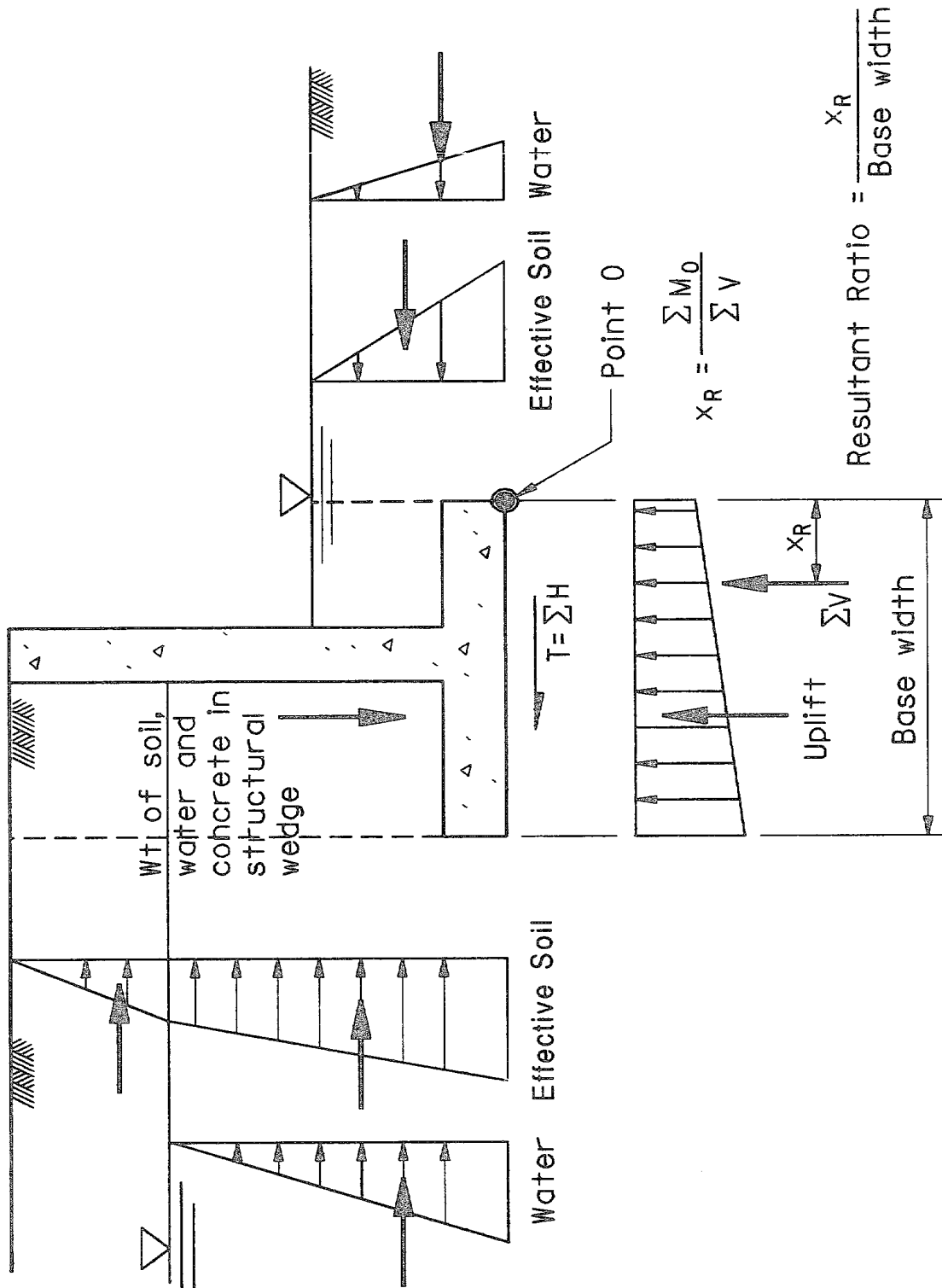

Figure 4-2. Forces for overturning analysis for wall with horizontal base

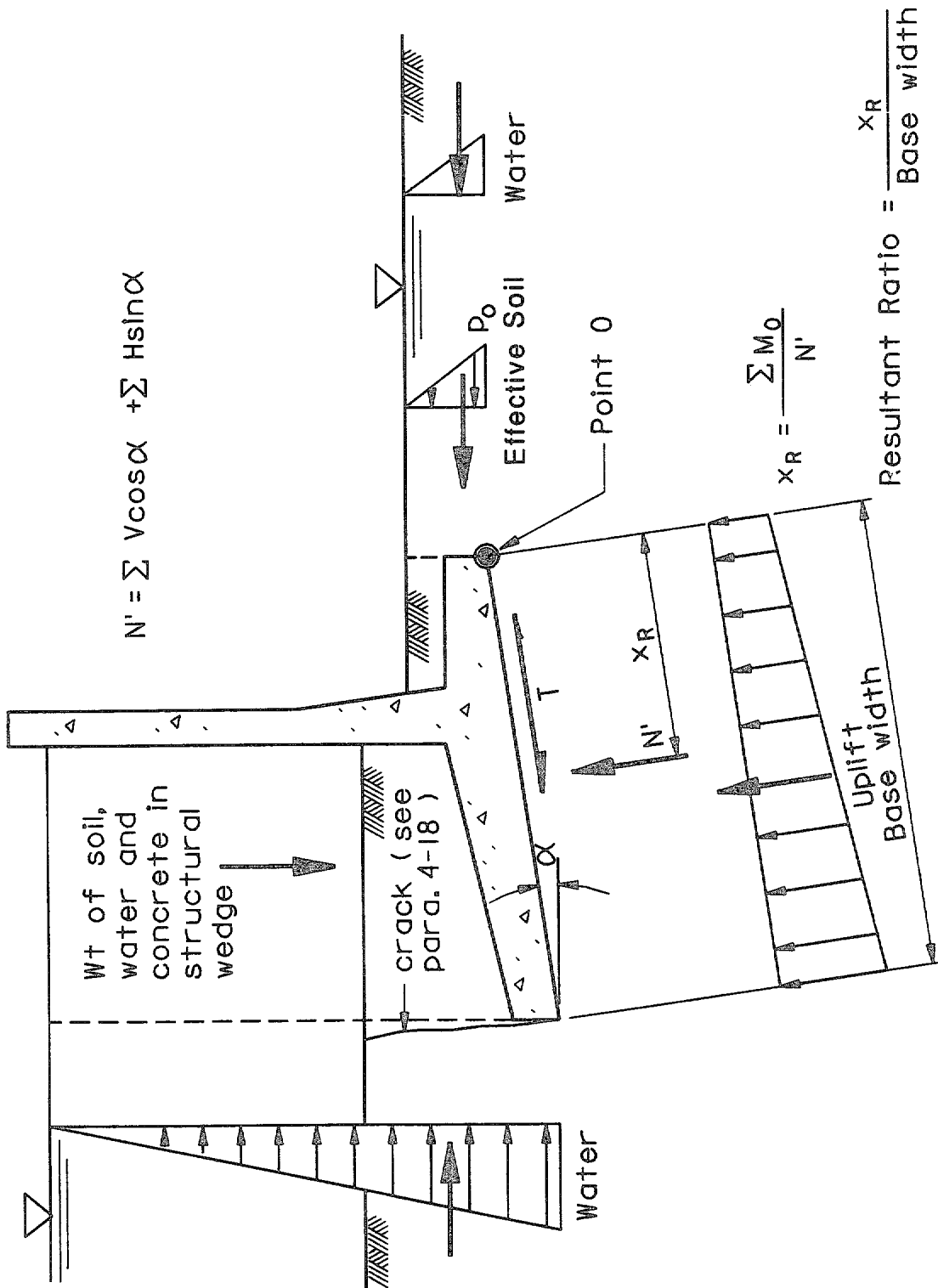

Figure 4-3. Forces for overturning analysis for wall with a sloping base

$$x_R = \frac{\text{summation of moments about Point O}}{\text{effective normal base force, } N'} \quad [4-3]$$

The resultant ratio is defined as:

$$\text{Resultant ratio} = \frac{x_R}{\text{sloped base width}} \quad [4-4]$$

The resultant ratio is related to the percent of the base in compression as shown in Figure 4-4. The percent of the base of the structure which is in compression should be checked for compliance with the overturning stability criteria discussed in paragraph 4-9.

b. Walls with Keys.

(1) Performing an overturning stability analysis on a wall with a key requires determining the resisting forces acting along the key and along the base. Since these forces are indeterminate and cannot be determined by equilibrium methods, the following assumptions are made in order to compute the overturning stability. For a wall with a horizontal base and a key, the shearing resistance of the base is assumed to be zero and the horizontal resisting force acting on the key is that required for equilibrium, as shown in Figure 4-5. For a wall with a sloping base and a key, the horizontal force required for equilibrium is assumed to act on the base and the key, as shown in Figure 4-6. In both cases the resisting soil force down to the bottom of the toe may be computed using at-rest earth pressure if the material on the resisting side will not lose its resistance characteristics with any probable change in water content or environmental conditions and will not be eroded or excavated during the life of the wall. See examples 3 and 6 of Appendix N for stability analyses of walls with keys.

(2) Prior to performing an overturning analysis, the depth of the key and width of the base should be determined from a sliding stability analysis.

c. Sloping Backfills. For an upward-sloping backfill, an additional shear force can be taken advantage of in the overturning analysis. The calculation of this shear force is shown in Figure 4-7. The magnitude of this shear force is just large enough to cause the horizontal forces acting on the stem to be equal to the part of the horizontal wedge force that lies above the heel of the wall. This will cause the force used for the structural design of the stem to be equal to the force used in the stability analyses. This force will also cause the summation of moments about the stem-toe-heel joint to equal zero for the structural design. The derivation of this shear force is given in Appendix K. A wall with a sloping backfill is shown in example 1 of Appendix N.

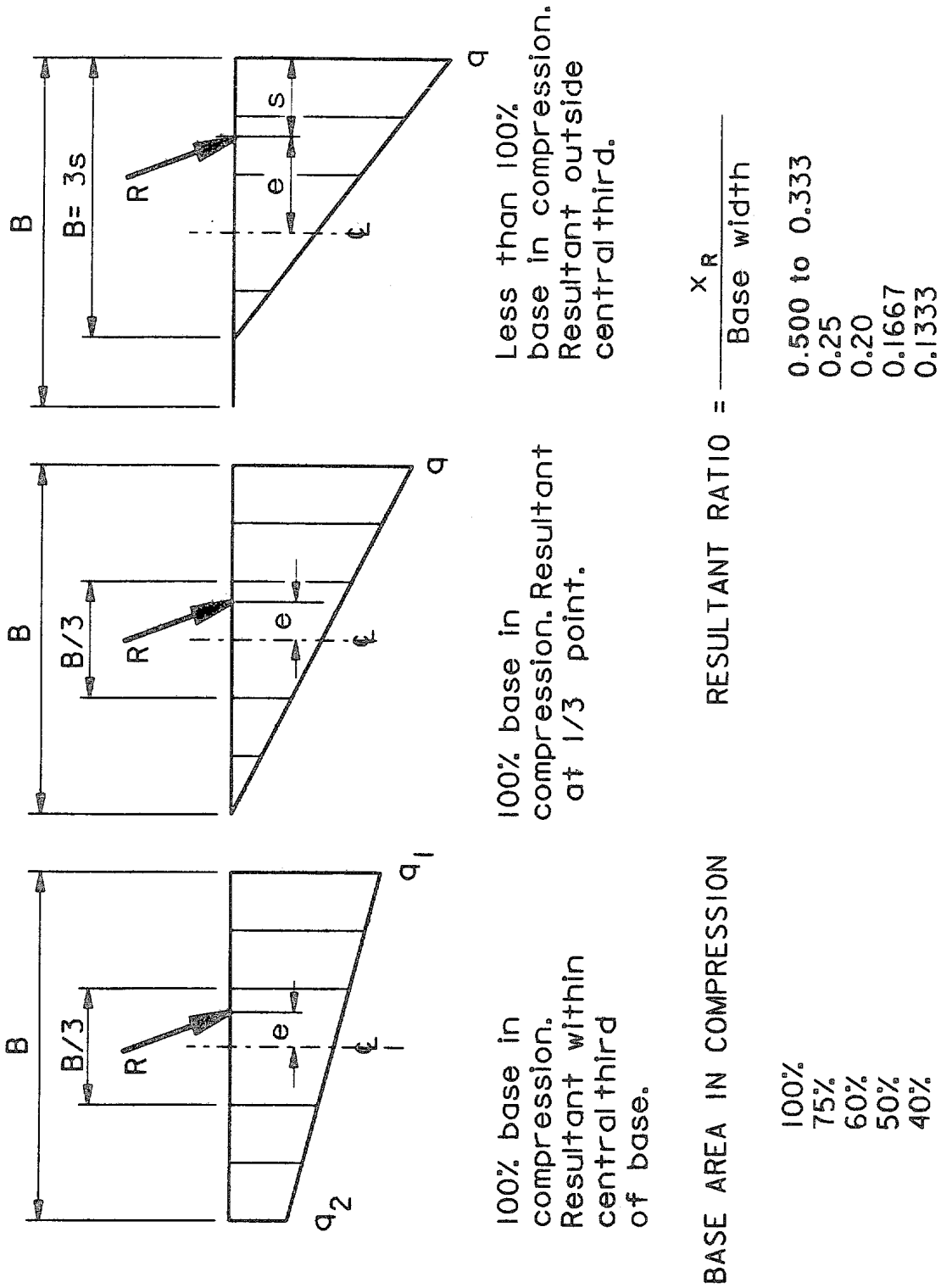

Figure 4-4. Relationship between base width in compression and resultant location

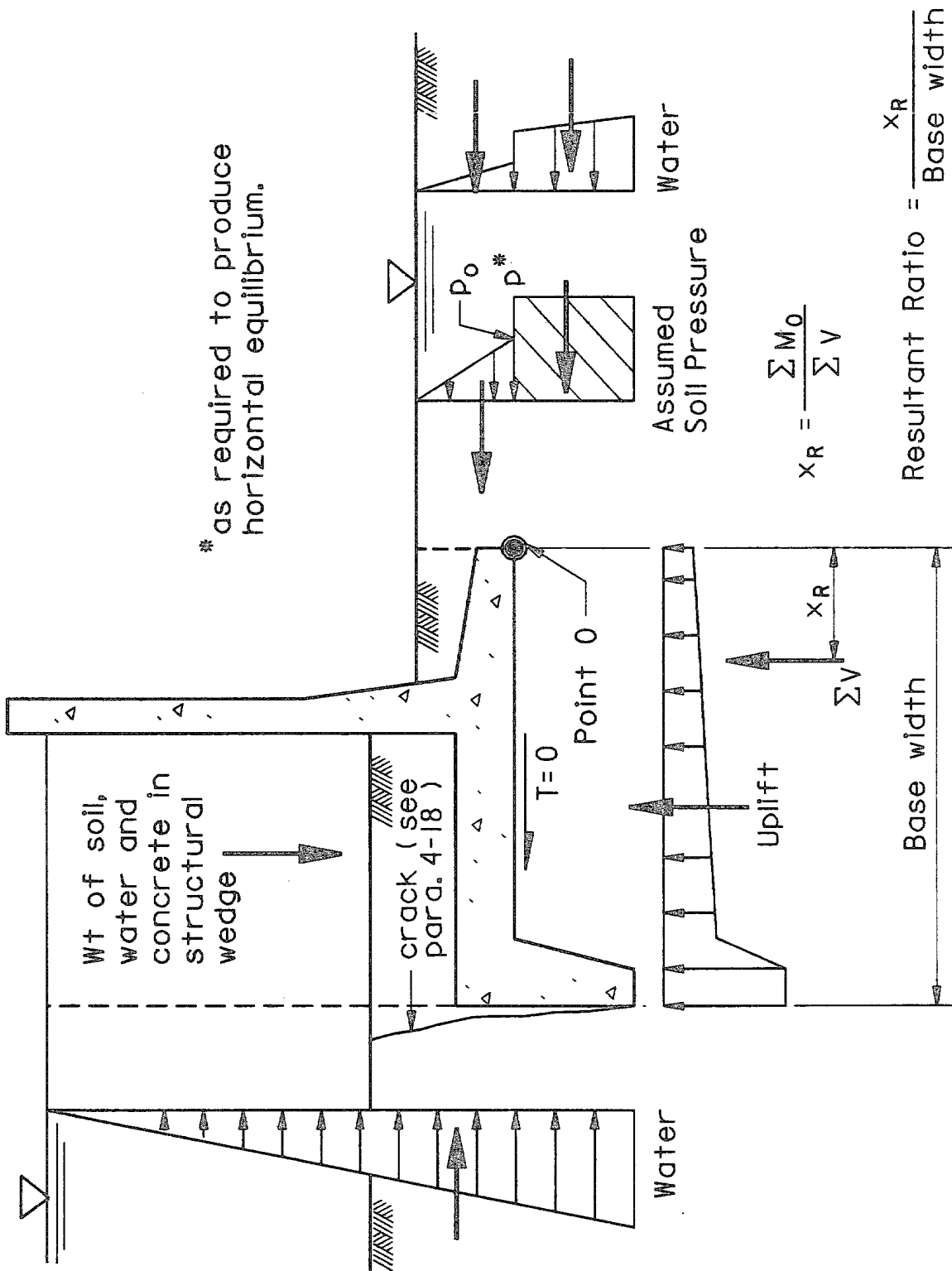

Figure 4-5. Forces for overturning analysis for wall with horizontal base and key

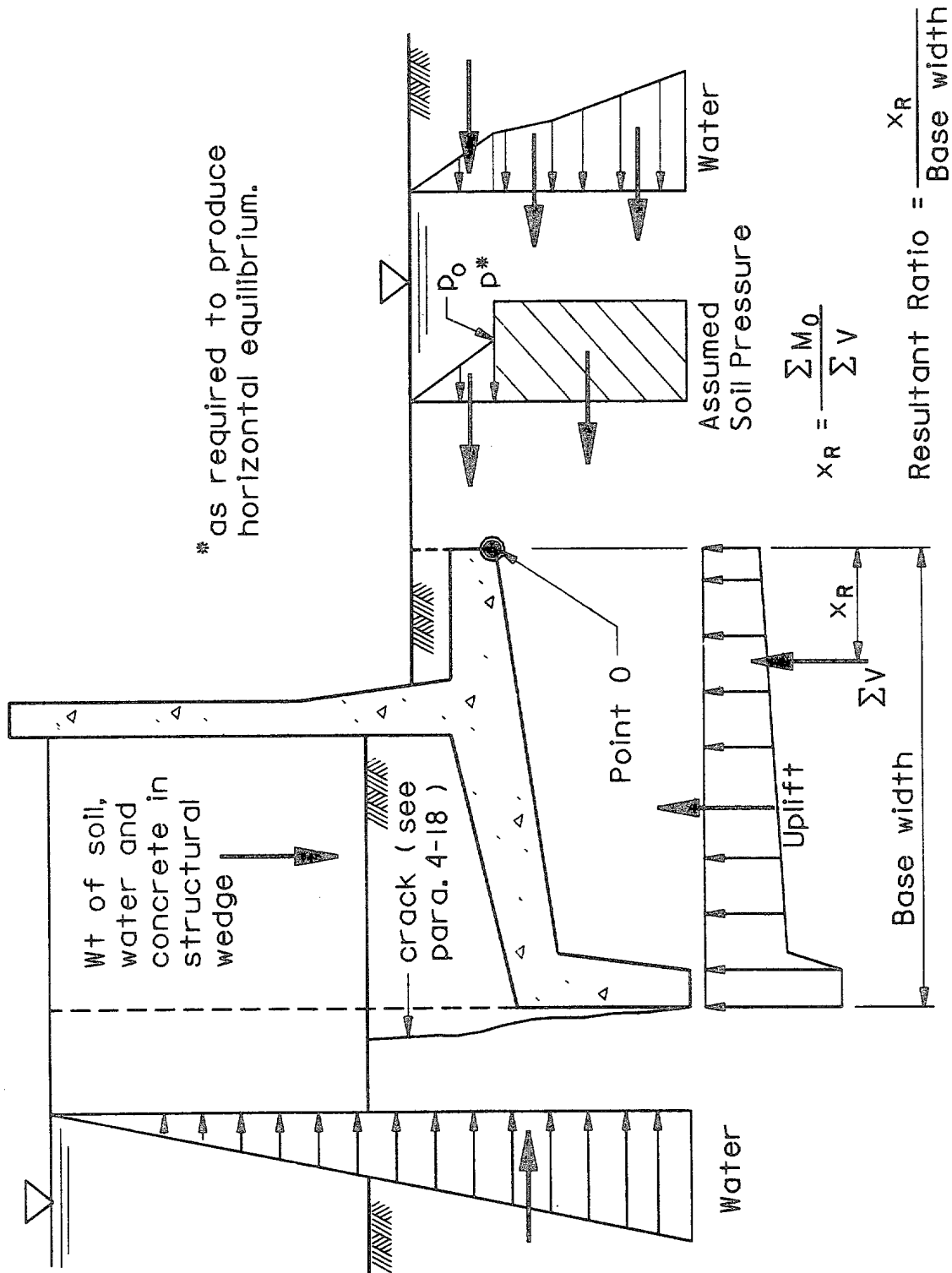
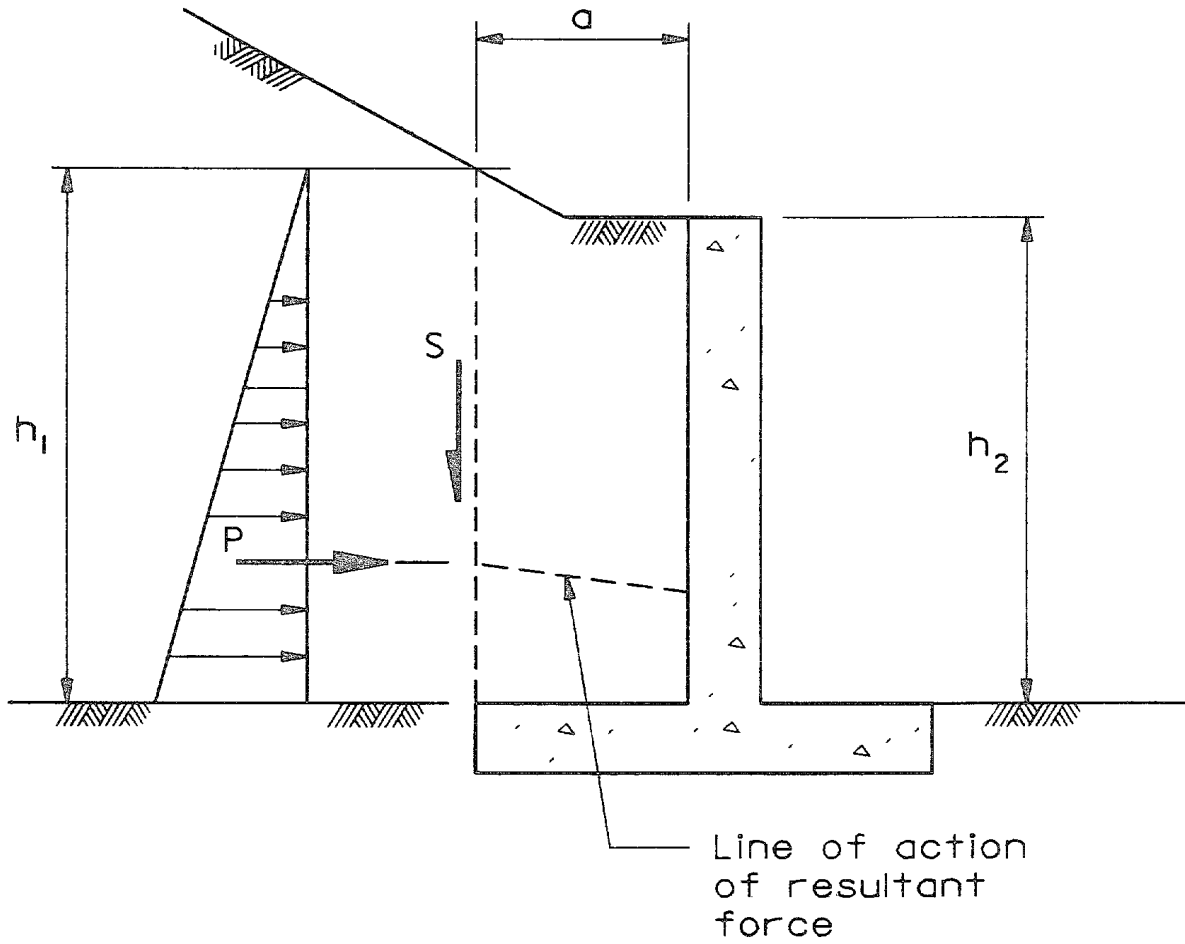

Figure 4-6. Forces for overturning analysis for wall with sloping base and key



$$S = \frac{P (h_1 - h_2)}{3a} = \text{Shear force when } h_1 > h_2$$

Figure 4-7. Shear force for upward sloping backfill

d. Uplift For Walls with Keys. For walls with keys, the soil may be assumed to remain in contact with the key and head loss to occur around the perimeter of the key and along the base even if the overturning analysis shows less than 100 percent of the base in compression.

4-9. Overturning Stability Criteria. The overturning stability requirements in Tables 4-1 through 4-3 are given as minimum percent base areas in compression. Figure 4-4 illustrates the relationship between the percent of the base area in compression and the resultant location.

Section IV. Structure Sliding Stability

4-10. Overview of Sliding Stability Analysis.

a. Purpose. The purpose of a sliding stability analysis is to assess the safety of a structure against a potential failure due to excessive horizontal deformations. The potential for a sliding failure may be assessed by comparing the applied shear forces to the available resisting shear forces along an assumed failure surface. A sliding failure is imminent when the ratio of the applied shear forces to the available resisting shear forces is equal to 1.

b. Analysis Model.

(1) The shape of the failure surface may be irregular depending on the homogeneity of the backfill and foundation material. The failure surface may be composed of any combination of plane and curved surfaces. However, for simplicity all failure surfaces are assumed to be planes which form the bases of wedges as shown in Figure 4-8.

(2) Except for very simple cases, most sliding stability problems encountered in engineering practice are statically indeterminate. To reduce a problem to a statically determinate one, the problem is simplified by dividing the system into a number of rigid body wedges, arbitrarily assuming the direction of the moment equilibrium forces which act between the wedges, and neglecting any frictional forces between adjacent wedges.

(3) Figure 4-8 also illustrates how the failure surface would be divided into wedges. The base of a wedge is formed from either a section of the failure surface that lies in a single soil material or along the base of the structure. The interface between any two adjacent wedges is assumed to be a vertical plane which extends from the intersection of the corners of the two adjacent wedges upward to the top soil surface. The base of a wedge, the vertical interface on each side of the wedge, and the top soil surface between the vertical interfaces define the boundaries of an individual wedge.

(4) In the sliding analysis, the retaining or flood wall and the surrounding soil are assumed to act as a system of wedges as shown in Figure 4-8. The soil-structure system is divided into one or more driving wedges, one structural wedge, and one or more resisting wedges.

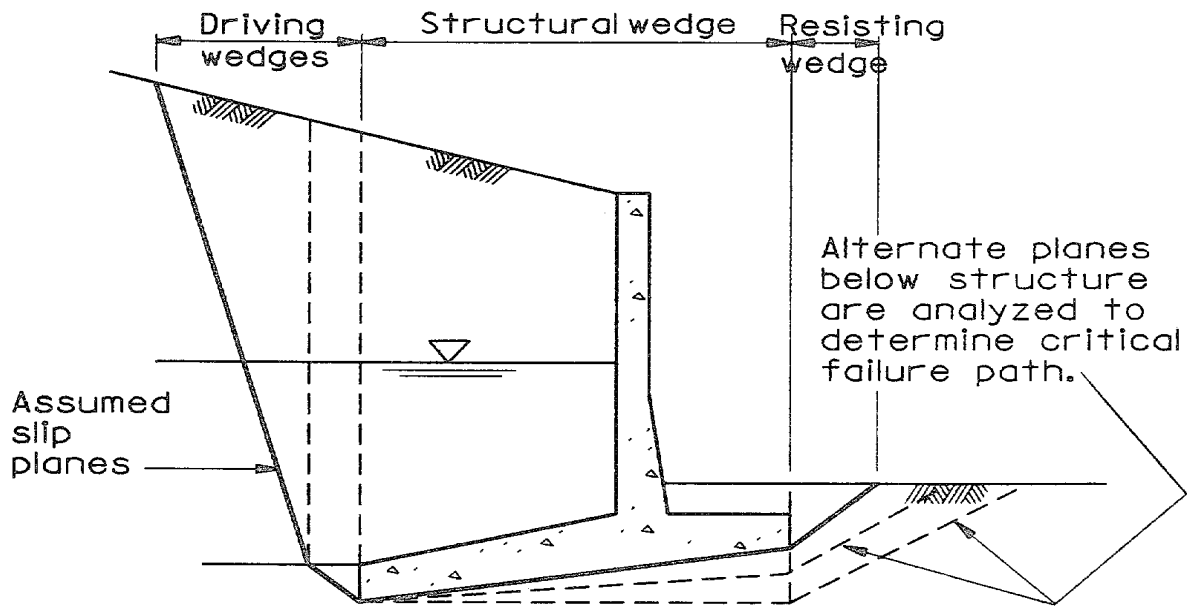

a. Failure plane for wall without a key

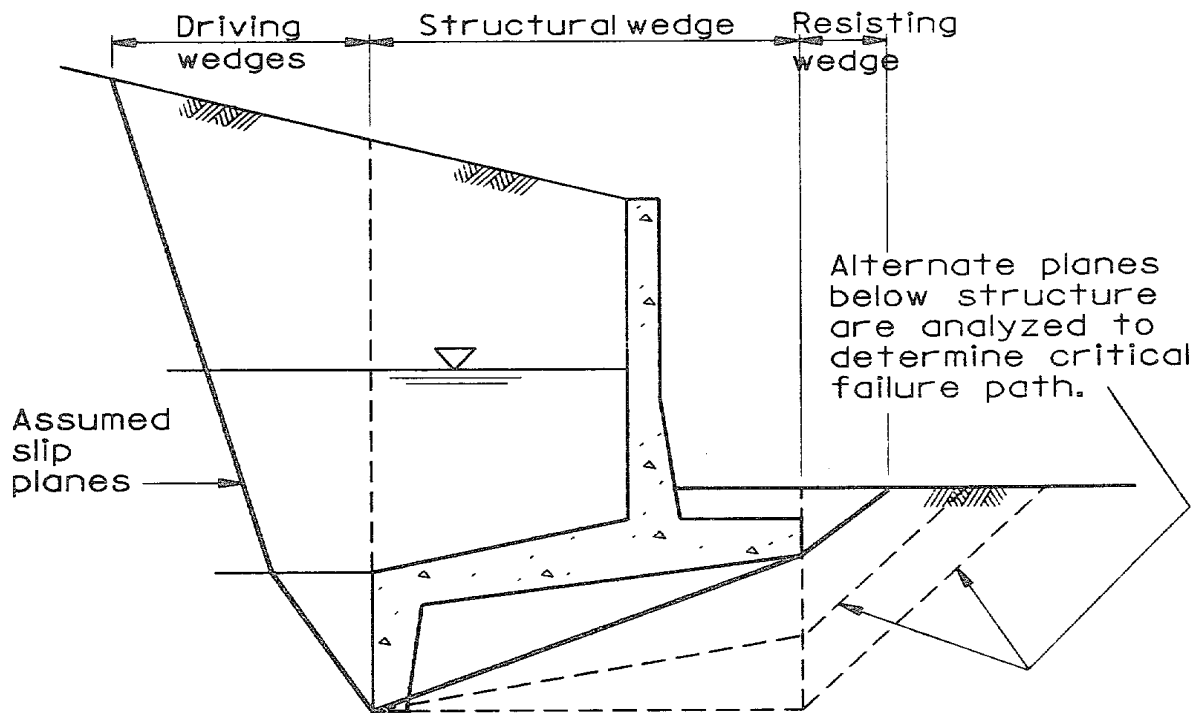

b. Failure plane for wall with a key

Figure 4-8. Typical soil/structure system with an assumed failure surface

(5) Depending on the geologic conditions of the foundation material, the location of the total failure surface or parts of the failure surface may be predetermined. The inclination of some of the failure planes or the starting elevation of the failure planes adjacent to the structure may be known due to natural constraints at the site. Conditions which warrant the predetermination of parts of the failure surface include bedding planes or cracks in a rock foundation.

c. Analysis Procedure of the Soil-Structure System. An iterative procedure can be used to find the critical failure surface. For an assumed factor of safety, the inclination of the base of each wedge is varied to produce a maximum driving force for a driving wedge or a minimum resisting force for a resisting wedge. The assumed factor of safety affects the critical inclination of the base of each wedge. The factor of safety is varied until a failure surface is produced that satisfies equilibrium. The failure surface which results from this procedure will be the one with the lowest factor of safety. Several base inclinations of the structural wedge, such as those shown in Figure 4-8, should be evaluated to determine the failure surface which has the lowest factor of safety.

4-11. Sliding Factor of Safety.

a. General. Limit equilibrium analysis is used to assess the stability against sliding. A factor of safety (FS) is applied to the factors which affect the sliding stability and are known with the least degree of certainty. These factors are the material strength properties. An FS is applied to the material strength properties in a manner that places the forces acting on the structure and soil wedges into equilibrium. Since the in situ strength parameters of rock and soil are never known exactly, one role of the FS is to compensate for the uncertainty that exists in assigning single values to such important parameters. In other words, the FS compensates for the difference between what may be the real shear strength and the shear strength assumed for the analysis.

b. Definition.

(1) A state of limiting equilibrium is said to exist when the applied shear stresses are equal to the maximum shear strength along a potential failure surface. Therefore, a structure is stable against sliding along a potential failure surface when the applied shear stress is less than the available shear strength along that surface. The ratio of the shear strength to the applied shear stress along a potential failure surface is defined as the FS, as shown in Equation 4-5.

$$FS = \frac{\tau_f}{\tau} = \frac{\sigma' (\tan \phi) + c}{\tau} \quad [4-5]$$

where

τ_f = maximum shear strength according to the Mohr-Coulomb failure criterion

τ = applied shear stress

(2) The sliding FS can also be defined as the ratio of the shear force (T_F) that would cause failure along the slip plane to the corresponding shear force (T) along the slip plane at service conditions (see Figure 4-9):

$$FS = \frac{T_F}{T} = \frac{N' \tan \phi + cL}{T} \quad [4-6]$$

where L is the length of base in compression for a 1-foot strip of wall.
For $c = 0$,

$$FS = \frac{N' \tan \phi}{N' \tan \phi_d} = \frac{\tan \phi}{\tan \phi_d} \quad [4-7]$$

or for $\phi = 0$,

$$FS = \frac{cL}{c_d L} = \frac{c}{c_d}$$

where $\tan \phi_d$, c_d is that portion of the shear strength considered to be mobilized or developed along the slip plane(s).

4-12. Assumptions and Simplifications.

a. Slip Surface. The slip surface can be a combination of planes and curved surfaces, but for simplicity, all slip surfaces are assumed to be planes. These planes form the bases of the wedges. It should be noted that for the analysis to be realistic, the assumed slip planes have to be kinematically possible. In rock, the slip planes may be predetermined by discontinuities in the foundation. If alternate planes are possible, all must be considered to find the most critical.

b. Two-Dimensional Analysis. The sliding equilibrium method presented is a two-dimensional analysis. This method should be extended to a three-dimensional analysis if unique three-dimensional geometric features and loads critically affect the sliding stability of a specific structure.

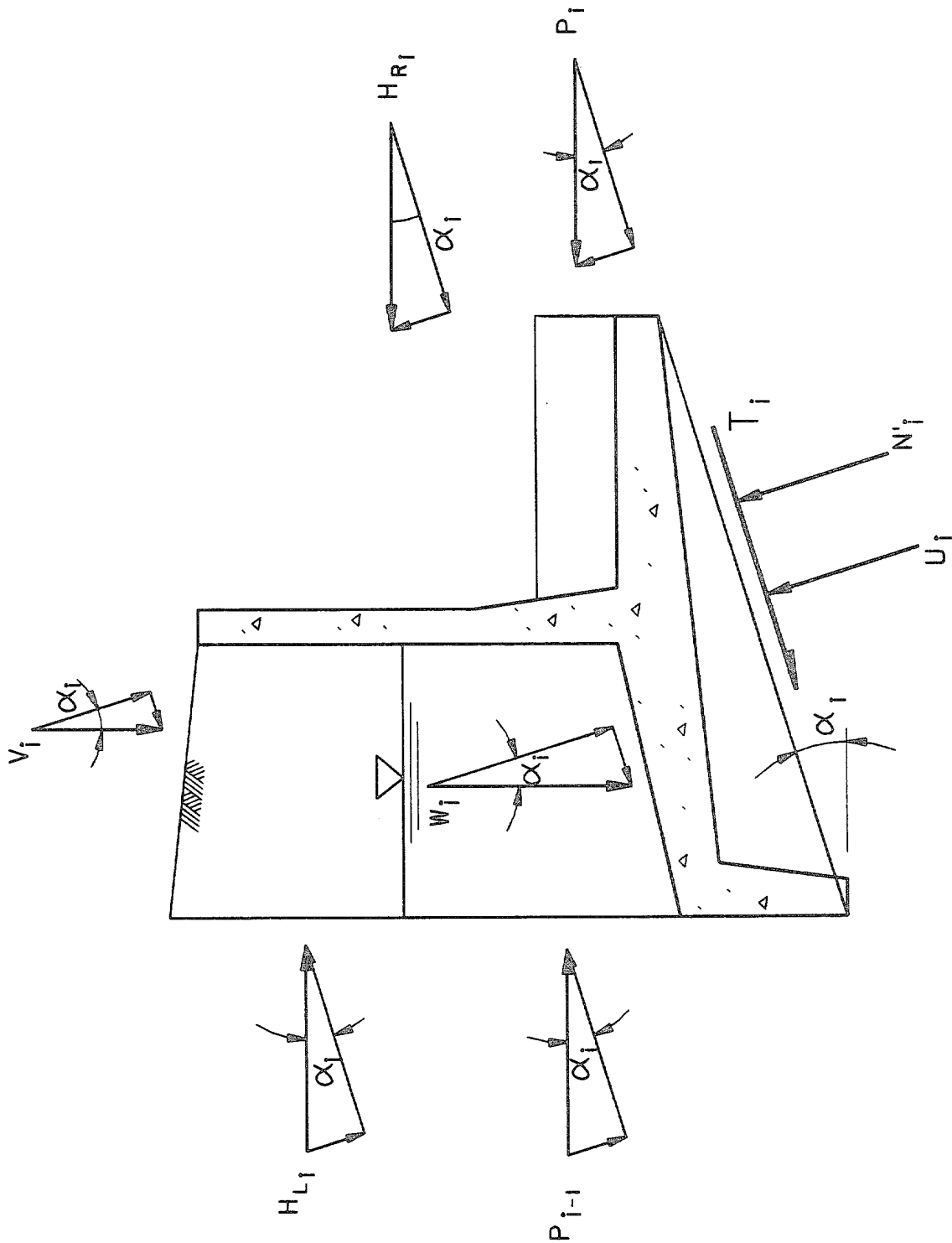

Figure 4-9. Free-body diagram of i th wedge

29 Sep 89

c. Force Equilibrium Only. Only force equilibrium is satisfied. Moment equilibrium is not considered. The shearing force acting parallel to the interface of any two wedges is assumed to be negligible. Therefore, the portion of the slip surface at the bottom of each wedge is loaded only by the forces directly above or below it. There is no interaction of vertical effects between the wedges. The resulting wedge forces are assumed horizontal.

d. Displacements. Considerations regarding displacements are excluded from the limit equilibrium approach. The relative rigidity of different foundation materials supporting the structure and the concrete structure itself may influence the results of the sliding stability analysis. Such complex structure-foundation systems may require a more intensive sliding investigation than a limit equilibrium approach. The effects of strain compatibility along the assumed slip surface may be approximated in the limit equilibrium approach by selecting the shear strength parameters from in situ or laboratory tests consistent with the failure strain selected for the stiffest material.

e. Relationship Between Shearing and Normal Forces. A linear relationship is assumed between the resisting shearing force and the normal force acting on the slip plane beneath each wedge. This relationship is determined by the Mohr-Coulomb failure criterion.

f. Structural Wedge. The general wedge equation is based on the assumption that shearing forces do not act on the vertical wedge boundaries. Hence, there can only be one structural wedge since concrete structures transmit significant shearing forces across vertical internal planes. Discontinuities in the slip path beneath the structural wedge should be modeled by assuming an average slip plane along the base of the structural wedge.

g. Interface of Other Wedges with Structural Wedge. The interface between the group of driving wedges and the structural wedge is assumed to be a vertical plane located at the heel of the structural wedge and extending to the base of the structural wedge. The interface between the group of resisting wedges and the structural wedge is assumed to be a vertical plane located at the toe of the structural wedge and extending to the base of the structural wedge.

4-13. General Wedge Equation.

a. Sign Convention.

(1) The geometry and sign convention of a typical i^{th} wedge and adjacent wedges are shown in Figure 4-10. The equations for the sliding stability of a general wedge system are derived using a right-hand coordinate system. The origin of each wedge is located at the lower left corner of the wedge. The x-axis is horizontal and the y-axis is vertical.

(2) Axes which are tangent (t) and normal (n) to a failure plane are inclined at an angle (α) to the +x- and +y-axes. A negative angle is formed

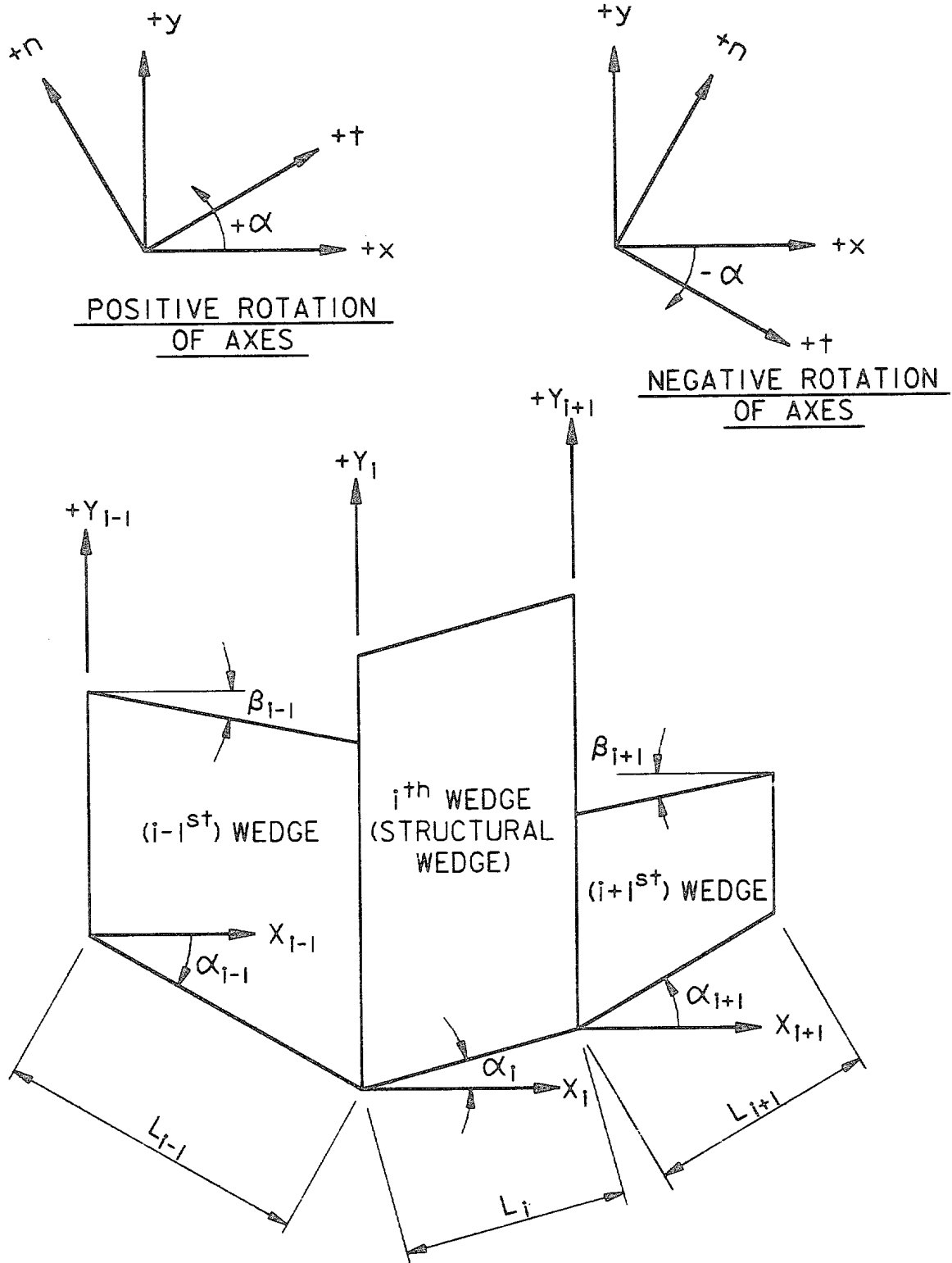

Figure 4-10. Geometry of typical i^{th} wedge and adjacent wedges

from a clockwise rotation of the axes. A positive angle is formed from a counterclockwise rotation of the axes.

b. Derivation.

(1) By writing equilibrium equations normal and parallel to the slip plane for a typical wedge as shown in Figure 4-9, solving for N'_i and T_i , and substituting the expressions for N'_i and T_i into Equation 4-6 for the factor of safety of the i^{th} wedge, the following equation results. (Refer to Appendix L for a detailed derivation.)

$$\begin{aligned}
 \text{FS} = & \left\{ \left[(W_L + V_i) \cos \alpha_i + (H_{Li} - H_{Ri}) \sin \alpha_i \right. \right. \\
 & \left. \left. + (P_{i-1} - P_i) \sin \alpha_i - U_i \right] \tan \phi_i + c_i L_i \right\} / \left[(H_{Li} - H_{Ri}) \cos \alpha_i \right. \\
 & \left. + (P_{i-1} - P_i) \cos \alpha_i - (W_i + V_i) \sin \alpha_i \right] \quad [4-8]
 \end{aligned}$$

solving for $(P_{i-1} - P_i)$ gives the general wedge equation,

$$\begin{aligned}
 (P_{i-1} - P_i) = & \left[(W_i + V_i) (\tan \phi_{di} \cos \alpha_i + \sin \alpha_i) - U_i \tan \phi_{di} \right. \\
 & \left. + (H_{Li} - H_{Ri}) (\tan \phi_{di} \sin \alpha_i - \cos \alpha_i) \right. \\
 & \left. + c_{di} L_i \right] / (\cos \alpha_i - \tan \phi_{di} \sin \alpha_i) \quad [4-9]
 \end{aligned}$$

where

i = number of wedge being analyzed

$(P_{i-1} - P_i)$ = summation of applied forces acting horizontally on the i^{th} wedge. (A negative value for this term indicates that the applied forces acting on the i^{th} wedge exceed the forces resisting sliding along the base of the wedge. A positive value for this term indicates that the applied forces acting on the i^{th} wedge are less than the forces resisting sliding along the base of the wedge.)

W_i = total weight of water, soil, rock, or concrete in the i^{th} wedge

V_i = any vertical force applied above the top of i^{th} wedge

$$\tan \phi_{di} = \tan \phi_i / FS$$

α_i = angle between slip plane of the i^{th} wedge and the horizontal (positive is counterclockwise)

U_i = uplift force exerted along slip plane of the i^{th} wedge

H_{Li} = any horizontal force applied above the top or below the bottom of the left side adjacent wedge

H_{Ri} = any horizontal force applied above the top or below the bottom of the right side adjacent wedge

c_{di} = c/FS

L_i = length along the slip plane of the i^{th} wedge

(2) This equation is used to compute the sum of the applied forces acting horizontally on each wedge for an assumed FS . The same FS is used for each wedge. The system of wedges is in equilibrium if the horizontal forces calculated from Equation 4-9, for all wedges, sum to zero.

4-14. Slip-Plane Angle.

a. Definition of Critical Slip-Plane Angle. The slip-plane angle α varies with the value of the FS . For a driving wedge, the critical α would be the angle that produces a maximum driving force as calculated using Equation 4-9. For a resisting wedge, the critical α would be the angle that produces a minimum resisting force as calculated using Equation 4-9. Since the determination of α is a trial-and-error procedure, for an initial trial the slip-plane angle α for a driving wedge can be approximated by:

$$\alpha = 45^\circ + \frac{\phi_d}{2} \quad [4-10]$$

where $\phi_d = \tan^{-1} (\tan \phi / FS)$. For a resisting wedge, the slip-plane angle can be approximated by:

$$\alpha = 45^\circ - \frac{\phi_d}{2} \quad [4-11]$$

b. Computation of Critical Slip Plane Angle. The above equations for the slip-plane angle are the exact solutions for wedges with a horizontal top surface with or without a uniform surcharge. Other methods to calculate the

critical slip angle, for conditions other than a horizontal top surface with or without a uniform surcharge, may be found in paragraph 3-13.

4-15. Single Wedge Analysis.

a. Introduction. A quick check of the sliding stability of a structure can be obtained by performing a single wedge analysis of the structural wedge using the same loadings computed from an overturning analysis if the minimum required sliding FS is no greater than 1.5. If a minimum sliding FS greater than 1.5 is used, driving forces would be larger than the forces calculated from the overturning analysis, which uses an SMF (paragraph 3-11) of two-thirds. In this case, the single wedge equation might incorrectly indicate the structure to satisfy criteria for the larger FS (see paragraph 4-15b(5) for removing this restraint). Example calculations are shown in Appendix N.

b. Procedure for Single Wedge Analysis.

(1) Compute the sliding resistance required for equilibrium parallel to the assumed sliding plane beneath the structural wedge. Use the forces computed from the overturning analysis for the same loading case being analyzed for sliding. The sliding resistance required for equilibrium is calculated as shown in Figure 4-11.

(2) Compute the total sliding resistance available along the assumed sliding plane beneath the structural wedge using the unfactored shear strength parameters and divide the total sliding resistance by the minimum factor of safety required for the case being analyzed.

(3) If the sliding resistance needed, as computed in step (1), is equal to or less than the available sliding resistance divided by the minimum sliding factor of safety as computed in step (2), a multiple wedge analysis is not required. A multiple wedge analysis would give a sliding FS equal to or greater than the minimum required. This check on the sliding stability can be expressed by:

$$T \leq \frac{N' \tan \phi + cL}{FS} \quad [4-12]$$

where

T = resultant of sliding resistance parallel to the assumed sliding plane required for equilibrium

N' = resultant of forces normal to the assumed sliding plane

$\tan \phi$ and c = unfactored shear strength parameters of the foundation material through which the sliding plane passes

L = length of sliding plane beneath the structure

FS = minimum sliding factor of safety required

If the assumed sliding plane is horizontal, T would equal the resultant of the horizontal forces and N' would equal the resultant of the vertical forces. See example 1 in Appendix N.

(4) If Equation 4-12 is not satisfied, perform a multiple wedge analysis to determine the actual sliding factor of safety (see the following paragraph).

(5) The necessity for a multiple wedge solution may be eliminated if the driving and resisting wedge forces are calculated using the minimum FS required. If Equation 4-12 is not satisfied for the FS required, a multiple wedge solution will show the same results. If Equation 4-12 is satisfied, the system has an FS equal to or greater than the minimum FS required.

4-16. Multiple Wedge Analysis.

a. Procedure.

(1) Divide the assumed sliding mass into a number of wedges, including a single structural wedge, based on the configuration and discontinuities of the backfill, wall proportions, and discontinuities of the foundation.

(2) Estimate the FS for the first trial.

(3) Compute the critical sliding angles for each wedge. For a driving wedge, the critical angle is the angle that produces a maximum driving force. For a resisting wedge, the critical angle is the angle that produces a minimum resisting force.

(4) Compute the uplift pressures, if any, along the slip plane. The effects of seepage should be included.

(5) Compute the weight of the wedges, including any water and surcharges.

(6) Compute the summation of the lateral forces for each wedge using the general wedge equation. In certain cases where the loadings or wedge geometries are complicated, the critical angles of the wedges may not be easily calculated. The general wedge equation may be used to iterate and find the critical angle of a wedge by varying the angle of the wedge to find a minimum resisting or maximum driving force.

(7) Sum the lateral forces for all the wedges.

(8) If the sum of the lateral forces is negative, decrease the FS and recompute the sum of the lateral forces. By decreasing the FS , a greater

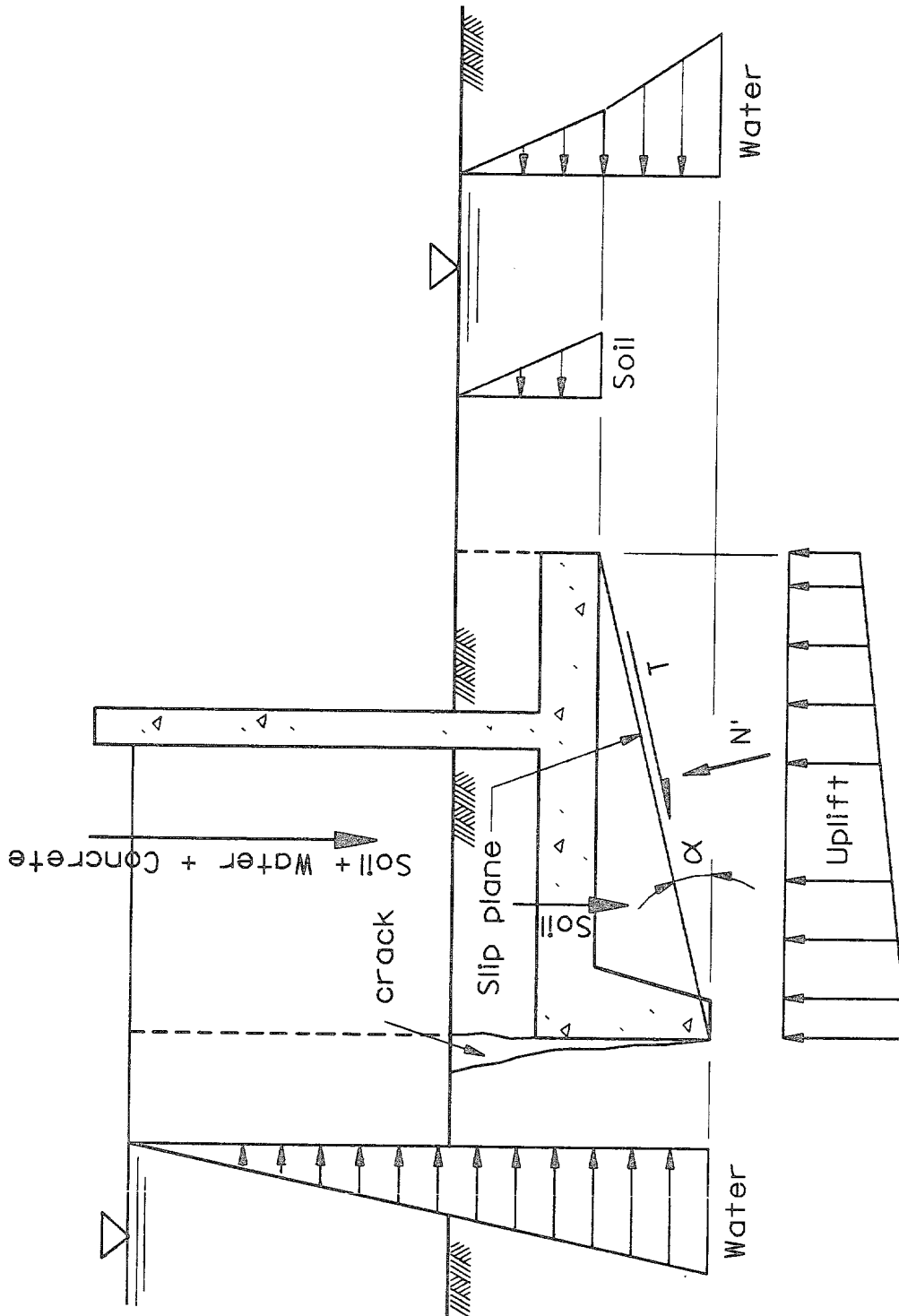

$$N' = \sum V \cos \alpha + \sum H \sin \alpha, \quad T = \sum H \cos \alpha - \sum V \sin \alpha$$

Figure 4-11. Single wedge analysis of sliding stability

percentage of the shearing strength along the slip planes is mobilized. If the sum of the lateral forces is positive, increase the FS and recompute the sum of the lateral forces. By increasing the FS, a smaller percentage of the shearing strength is mobilized.

(9) Continue this trial-and-error process until the sum of the lateral forces is approximately zero for the FS used. This will determine the FS that causes the sliding mass to be in horizontal equilibrium.

(10) If the FS is less than the minimum required, redesign by widening or sloping the base or by providing a key.

b. Computer Program. The computer program CSLIDE (Appendix O) can assist in performing a multiple wedge sliding analysis.

4-17. Sliding Stability Criteria. The sliding stability criteria are given in terms of a minimum factor of safety for the various loading conditions as shown in Tables 4-1 through 4-3. Guidance on deep-seated sliding is given in Chapter 5.

4-18. Design Considerations.

a. Effects of Cracks in Foundation. Sliding analyses should consider the effects of cracks on the active side of the structural wedge in the foundation material due to differential settlement, shrinkage, or joints in the rock mass. The depth of cracking in cohesive foundation material with a plane ground surface can be estimated with the following equations.

$$d_c = \frac{2c_d}{\gamma' \sqrt{K_A}} = \frac{2c_d}{\gamma'} \tan \left(45^\circ + \frac{\phi_d}{2} \right) \quad [4-13]$$

where

$$c_d = c/FS$$

$$\phi_d = \tan^{-1} (\tan \phi/FS)$$

$$\gamma' , K_A \quad (\text{see Equation 3-11})$$

For sloping backfills see Appendix I. The value d_c in a cohesive foundation and the depth of cracking in massive strong rock foundations should be assumed to extend to the base of the structural wedge. The depth of cracking in a level clay blanket should be computed using Equation 4-13. Full hydrostatic pressure should be assumed to act at the bottom of the crack. The hydraulic gradient across the base of the structural wedge should reflect the presence of a crack at the heel of the structural wedge. Examples showing the calculation of d_c are found in Appendix N in examples 3, 4, 5, 6, and 7.

b. Passive Resistance. When passive resistance is used, special considerations must be made. Rock or soil that may be subjected to high velocity water scouring should not be used unless amply protected. Also, the compressive strength of rock layers must be sufficient to develop the wedge resistance. In some cases, wedge resistance should not be assumed without resorting to special treatment, such as rock anchors.

Section V. Bearing Capacity Analysis

4-19. General Computations. The bearing capacity is checked for the same loading conditions as determined by the overturning analysis for each case analyzed. The bearing capacity should be checked along the same plane assumed in the sliding analysis. A normal (N') and tangent (T) force are calculated for the structural wedge along the assumed bearing plane. These forces are shown in Figure 4-11. T and N' are used in combination to check the bearing capacity. The bearing capacity analysis discussed in Chapter 5 and in the CBEAR User's Guide (Mosher and Pace 1982) (see Appendix O) considers both the normal and tangent components of the resultant force at the base of the structure. The factor of safety against a bearing failure can be computed by dividing the normal component of the ultimate bearing capacity by the effective normal force applied to the structural wedge as shown below:

$$FS = \frac{Q}{N'} \quad [4-14]$$

where

Q = normal component of the ultimate bearing capacity

N' = effective normal force applied to the structural wedge

The value computed from the general bearing capacity equation in Chapter 5 is the bearing capacity normal to the base of the structure. The computer program CBEAR (Appendix O) can assist in performing a bearing capacity analysis. Example calculations are shown in Appendix N.

4-20. Inadequate Bearing Capacity. If the factor of safety against bearing failure is insufficient, consideration should be given to increasing the width of the base, lowering the base of the wall, or founding the wall on piles.

4-21. Bearing Capacity Criteria. The criteria for bearing capacity are given in terms of a factor of safety as defined in paragraph 4-19 and shown in Tables 4-1 through 4-3.

Section VI. Summary of Design Procedures

4-22. Design Procedures. Figure 4-12 presents a summary of the design procedures discussed in this chapter.

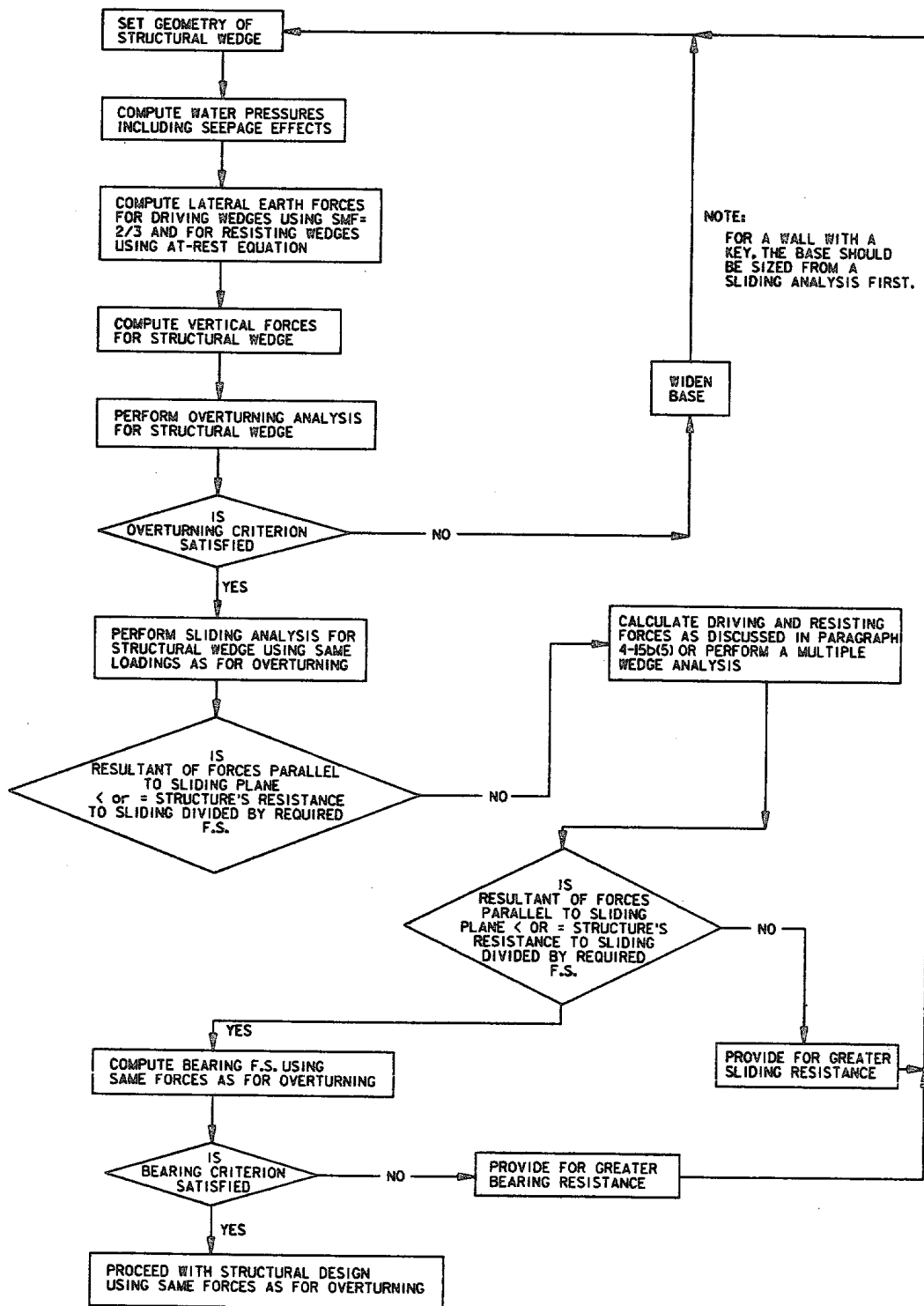

Figure 4-12. Wall design flowchart

CHAPTER 5

FOUNDATION ANALYSES

Section I. Bearing Capacity of Wall Foundations

5-1. Analysis Principles and Methods.

a. EM 1110-2-1903. A discussion of the principles and methods involved in analyzing bearing capacity is contained in EM 1110-2-1903. The manual concludes that Terzaghi's general bearing capacity equation, $q = CN_c + wz N_q + WbN_w$, is preferred. However, the manual does not address modifying the general equation for effects of embedment, inclined loads, sloping bases, passive-type wedges with sloping surfaces, overburden pressure, and eccentric loads (moment-induced stresses), all of which are needed for computing the bearing capacity of retaining and flood walls. The computer program CBEAR (Appendix O) can assist in these computations.

b. Mode of Failure. The mode of failure depends on the relative compressibility of the soil, loading conditions, and geometric considerations (Vesic 1975). This manual is restricted to general shear failure of shallow strip foundations, i.e., those whose widths are greater than their embedment. A general shear failure normally exists for dense sand and stiff clay. However, for loose sand and soft clay, which may occur more frequently for flood walls constructed in a flood plain, the bearing capacity should be computed based upon local shear conditions (Vesic 1975).

c. Factor of Safety. The FS is calculated as follows:

$$FS = \frac{Q}{N'} \quad [5-1]$$

where

N' = effective normal force applied to the base of the structure

Q = normal component to the base of the structure of the ultimate bearing capacity

The minimum acceptable bearing capacity factors for retaining walls and inland and coastal flood walls are listed by loading case in Tables 4-1 through 4-3. For each loading case, the same loadings as determined by the overturning analysis should be used. Options to consider in the event of inadequate bearing capacity have been presented in paragraph 4-20.

5-2. General Bearing Capacity Equation. The general bearing capacity equation for a strip footing is:

$$Q = \bar{B} \left[(\xi_{cd} \xi_{ci} \xi_{ct} \xi_{cg} c N_c) + (\xi_{qd} \xi_{qi} \xi_{qt} \xi_{qg} q_o N_q) + \frac{(\xi_{\gamma d} \xi_{\gamma i} \xi_{\gamma t} \xi_{\gamma g} \bar{B} \gamma N_{\gamma})}{2} \right] \quad [5-2]$$

where

Q = normal component of the ultimate bearing capacity of the foundation

\bar{B} = effective width of the base (B - 2e, as shown in Figure 5-1)

B = width of the geometric base (as shown in Figure 5-1)

e = eccentricity of the load with respect to geometric base width

c = cohesion parameter of the foundation

ξ = factors as explained in paragraphs 5-4 through 5-8

N_c, N_q, N_{γ} = bearing capacity factors for a strip load

q_o = effective overburden pressure on the plane passing through the base of the footing

γ = effective unit weight of the foundation material,
 γ_{buoyant} below water table, γ_{moist} above

Figure 5-1 illustrates the meanings of all of the terms required to use the information given in paragraphs 5-3 through 5-8. The general bearing capacity equation is taken from the CBEAR user's guide (Mosher and Pace 1982) (see also Appendix O). The appropriate soil foundation shear strength for retaining walls and inland and coastal flood walls is listed, by loading case, in Tables 4-1 through 4-3.

5-3. Bearing Capacity Factors. Bearing capacity factors for a horizontal strip footing under vertical loading are:

$$N_q = \left[e^{(\pi \tan \phi)} \right] \tan^2 \left(45^\circ + \frac{\phi}{2} \right) \quad [5-3a]$$

$$N_c = (N_q - 1) \cot \phi \quad (\text{when } \phi > 0) \quad [5-3b]$$

or

$$N_c = 5.14 \quad (\text{when } \phi = 0) \quad [5-3c]$$

$$N_{\gamma} = (N_q - 1) \tan (1.4\phi) \quad [5-3d]$$

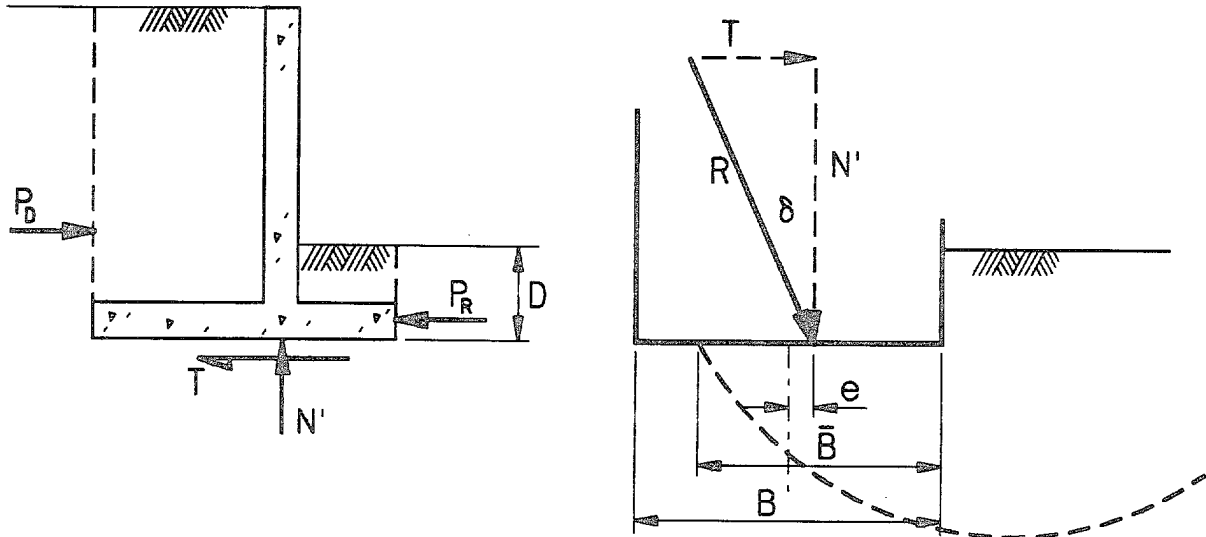

Load inclination, $\delta = \tan^{-1} (T/N')$
 Effective width $\bar{B} = B - 2e$

a. Horizontal base

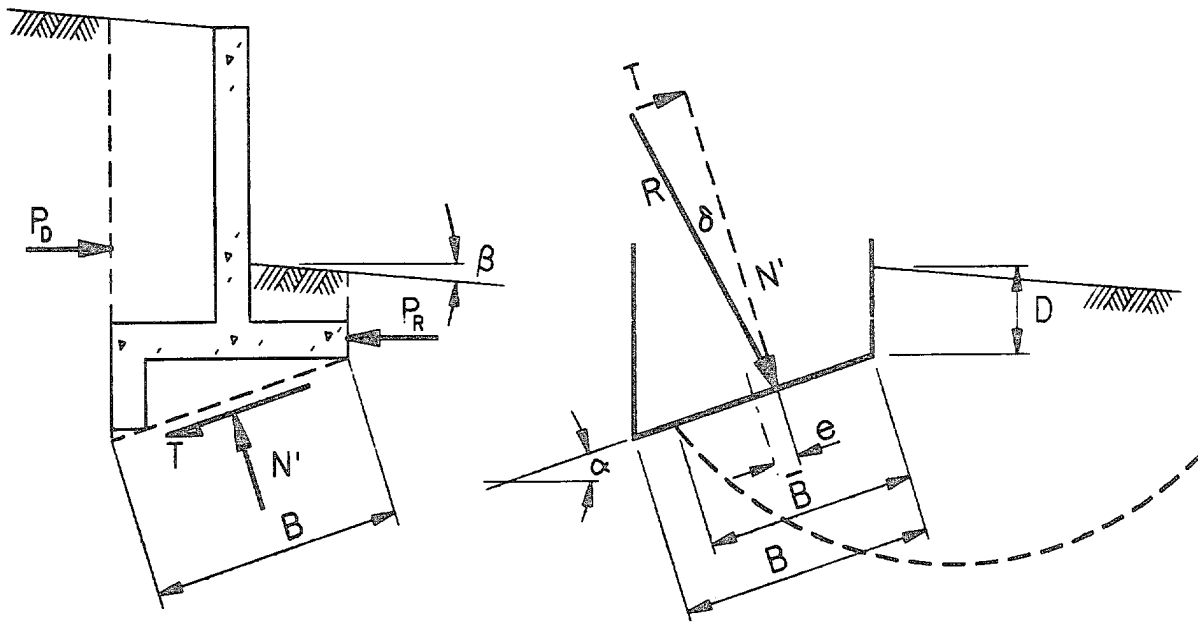

b. Keyed base, sloping ground

Figure 5-1. Terms used in bearing capacity equation

Bearing capacity factor values for ϕ , ranging between 0 and 50 degrees, are given in Table 5-1.

5-4. Embedment Factors. Embedment factors take into consideration the shearing resistance along the foundation slip plane that exists in the soil above the base of the footing, on the toe side of a wall. These factors can be computed as:

$$\xi_{cd} = 1 + 0.2 \left(\frac{D}{B} \right) \tan \left(45^\circ + \frac{\phi}{2} \right) \quad [5-4a]$$

$$\xi_{qd} = \xi_{\gamma d} = 1 \quad (\text{when } \phi = 0^\circ) \quad [5-4b]$$

or

$$\xi_{qd} = \xi_{\gamma d} = 1 + 0.1 \left(\frac{D}{B} \right) \tan \left(45^\circ + \frac{\phi}{2} \right) \quad (\text{when } \phi > 10^\circ) \quad [5-4c]$$

When ϕ lies between 0 and 10 degrees, a linear interpolation can be made for $\xi_{\gamma d}$ between 1 for $\phi = 0^\circ$, and $1 + 0.1(D/B) \tan(45^\circ + \phi/2)$ for $\phi = 10^\circ$.

Embedment factors account for the shear strength above the base of the footing. Their use may be unconservative if the shear strength does not exist.

5-5. Inclination Factors. Inclination factors account for the effect of load inclination for concentrically loaded foundations. They are computed as follows:

$$\xi_{qi} = \xi_{ci} = \left(1 - \frac{\delta^\circ}{90^\circ} \right)^2 \quad [5-5a]$$

$$\xi_{\gamma i} = \left(1 - \frac{\delta^\circ}{\phi} \right)^2 \quad [5-5b]$$

Where δ is the angle that the line of action of the load makes with a line drawn normal to the base. If $\delta > \phi$, $\xi_{\gamma i}$ should be set equal to zero.

Table 5-1
Bearing Capacity Factors (CBEAR User's Guide)*

ϕ	N_c	N_q	N_γ	$\tan \phi$	$\tan^2 \left(45^\circ + \frac{\phi}{2} \right)$
0	5.14	1.00	0.00	0.0000	1.0000
1	5.38	1.09	0.00	0.0175	1.0355
2	5.63	1.20	0.01	0.0349	1.0723
3	5.90	1.31	0.02	0.0524	1.1105
4	6.19	1.43	0.04	0.0699	1.1500
5	6.49	1.57	0.07	0.0875	1.1910
6	6.81	1.72	0.11	0.1051	1.2335
7	7.16	1.88	0.15	0.1228	1.2776
8	7.53	2.06	0.21	0.1405	1.3233
9	7.92	2.25	0.28	0.1584	1.3709
10	8.34	2.47	0.37	0.1763	1.4203
11	8.80	2.71	0.47	0.1944	1.4716
12	9.28	2.97	0.60	0.2126	1.5250
13	9.81	3.26	0.74	0.2309	1.5805
14	10.37	3.59	0.92	0.2493	1.6382
15	10.98	3.94	1.13	0.2679	1.6984
16	11.63	4.34	1.37	0.2867	1.7610
17	12.34	4.77	1.66	0.3057	1.8263
18	13.10	5.26	2.00	0.3249	1.8944
19	13.93	5.80	2.40	0.3443	1.9655
20	14.83	6.40	2.87	0.3640	2.0396
21	15.82	7.07	3.42	0.3839	2.1171
22	16.88	7.82	4.07	0.4040	2.1980
23	18.05	8.66	4.82	0.4245	2.2826
24	19.32	9.60	5.72	0.4452	2.3712
25	20.72	10.66	6.77	0.4663	2.4639
26	22.25	11.85	8.00	0.4877	2.5611
27	23.94	13.20	9.46	0.5095	2.6629
28	25.80	14.72	11.19	0.5317	2.7698
29	27.86	16.44	13.24	0.5543	2.8821

(Continued)

* (Mosher and Pace 1982).

Table 5-1 (Concluded)

ϕ	N_c	N_q	N_γ	$\tan \phi$	$\tan^2 \left(45^\circ + \frac{\phi}{2} \right)$
30	30.14	18.40	15.67	0.5774	3.0000
31	32.67	20.63	18.56	0.6009	3.1240
32	35.49	23.18	22.02	0.6249	3.2546
33	38.64	26.09	26.17	0.6494	3.3921
34	42.16	29.44	31.15	0.6745	3.5371
35	46.12	33.30	37.15	0.7002	3.6902
36	50.59	37.75	44.43	0.7265	3.8518
37	55.63	42.92	53.27	0.7536	4.0228
38	61.35	48.93	64.08	0.7813	4.2037
39	67.87	55.96	77.33	0.8098	4.3955
40	75.31	64.20	93.69	0.8391	4.5989
41	83.86	73.90	113.99	0.8693	4.8149
42	93.71	85.38	139.32	0.9004	5.0447
43	105.11	99.02	171.15	0.9325	5.2893
44	118.37	115.31	211.41	0.9657	5.5500
45	133.88	134.88	262.75	1.0000	5.8284
46	152.10	158.51	328.74	1.0355	6.1260
47	173.64	187.21	414.34	1.0724	6.4447
48	199.26	222.31	526.47	1.1106	6.7865
49	229.93	265.51	674.94	1.1504	7.1536
50	266.89	319.07	873.88	1.1918	7.5486

5-6. Base Tilt Factors. These factors are used to take into account the effect of a sloping base. The base tilt factors are computed as:

$$\xi_{qt} = \xi_{\gamma t} = (1 - \alpha \tan \phi)^2 \quad (\alpha \text{ in radians}) \quad [5-6a]$$

$$\xi_{ct} = 1 - \left(\frac{2\alpha}{\pi + 2} \right) \quad (\alpha \text{ in radians}) \quad (\text{when } \phi = 0^\circ) \quad [5-6b]$$

$$\xi_{ct} = \xi_{qt} - \frac{1 - \xi_{qt}}{N_c \tan \phi} \quad (\text{when } \phi > 0^\circ) \quad [5-6c]$$

where α is the angle the slip plane of the structural wedge makes with the horizontal, measured in radians. The sign of α will follow the sign convention given in Chapter 4.

5-7. Ground Slope Factors. Ground slope factors are used to correct for a sloping ground surface on the toe side of the wall. The factors are computed as:

$$\xi_{\gamma g} = \xi_{qg} = [1 - \tan(\beta)]^2 \quad [5-7a]$$

$$\xi_{cg} = 1 - \left[\frac{2\beta}{(\pi + 2)} \right] \quad (\beta \text{ in radians}) \quad (\text{when } \phi = 0^\circ) \quad [5-7b]$$

$$N_\gamma = -2 \sin \beta \quad (\text{when } \phi = 0^\circ) \quad [5-7c]$$

$$\xi_{cg} = \xi_{qg} - \frac{1 - \xi_{qg}}{N_c \tan \phi} \quad (\text{when } \phi > 0^\circ) \quad [5-7d]$$

where β is the angle the ground surface makes with the horizontal, measured in radians. β is positive when the ground slopes down and away from the footing.

5-8. Effective Overburden Pressure. q_0 is defined as the effective vertical stress due to the soil and/or surface loads above the base of the footing, on the toe side of the wall, as follows:

$$q_o = \gamma' D \quad [5-8a]$$

where

γ' = effective unit weight of the overlying soil

D = depth from the soil surface to the base of the structural wedge

For the special case of a sloping surface, compute q_o as:

$$q_o = \gamma' D \cos [ABS(\beta)] \quad [5-8b]$$

5-9. Combination of Factors. As discussed in the CBEAR user's guide (Mosher and Pace 1982), the correction factors for the load inclination, base tilt, and ground slope and the adjustment for the load eccentricity should only be used in unison when all of these factors tend to produce failure in the same direction.

5-10. Example. Example problems using the general bearing capacity equation are presented in Appendix N.

Section II. Other Considerations

5-11. Settlement.

a. EM 1110-2-1904. A discussion on the various factors involved in the settlement of a structure, on methods for estimating settlements, and on the limitations in the accuracy of conducting settlement analyses from laboratory tests is contained in EM 1110-2-1904. The principles and methods presented are applicable to a majority of civil works projects. Additional information for unique or special projects can be obtained from various texts on soil mechanics. The computer program CSETT (Appendix O) can assist in performing a settlement analysis.

b. Allowable Settlement. The maximum value of angular distortion (settlement/length of structure) which can be tolerated without cracking of reinforced concrete retaining walls is 0.002 to 0.003 radian (Duncan and Buchignani 1976).

5-12. Deep-Seated Sliding. A deep-seated sliding analysis should be performed to check for sliding within weak layers which may exist beneath structures. The analysis should be in accordance with procedures outlined in paragraph 4-16. Active and passive wedges should be located a sufficient distance apart to allow a rotational slip surface to develop. Generally, a slip plane inscribed in an arc with a radius equal to the height of the active wedge will comply with this requirement (Figures 5-2 and 5-3). When the wall is resting on thick strata of weak soils, shallow shear failure should be

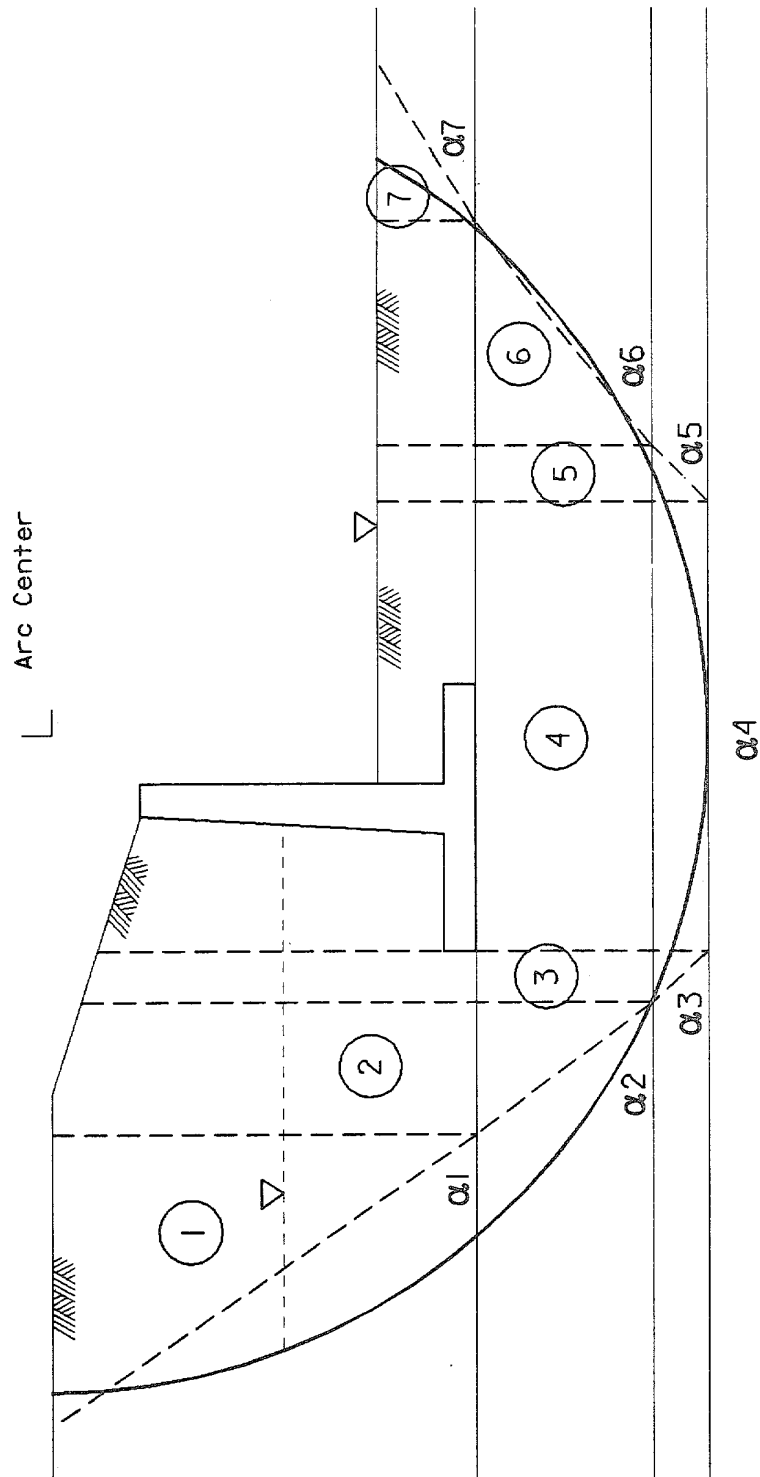

Figure 5-2. Deep-seated sliding analysis with vertical face of driving wedge at heel

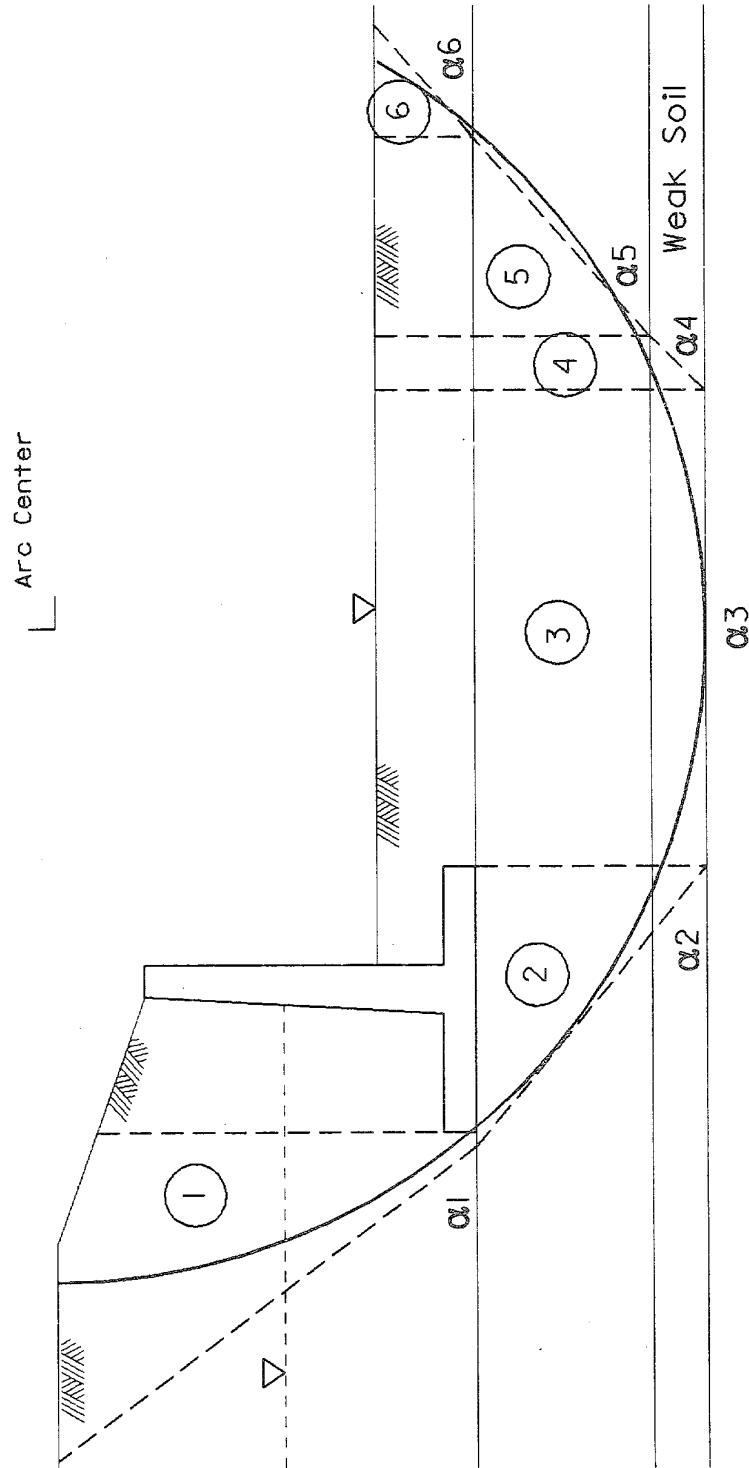

Figure 5-3. Deep-seated sliding analysis with vertical face of driving wedge at toe

investigated. This may be assumed to occur below the base of the retaining or flood wall along a cylindrical surface passing through the heel (Figure 5-4). The minimum factor of safety, which must not be less than 1.5, is determined by trial and error by changing the center of the trial circle.

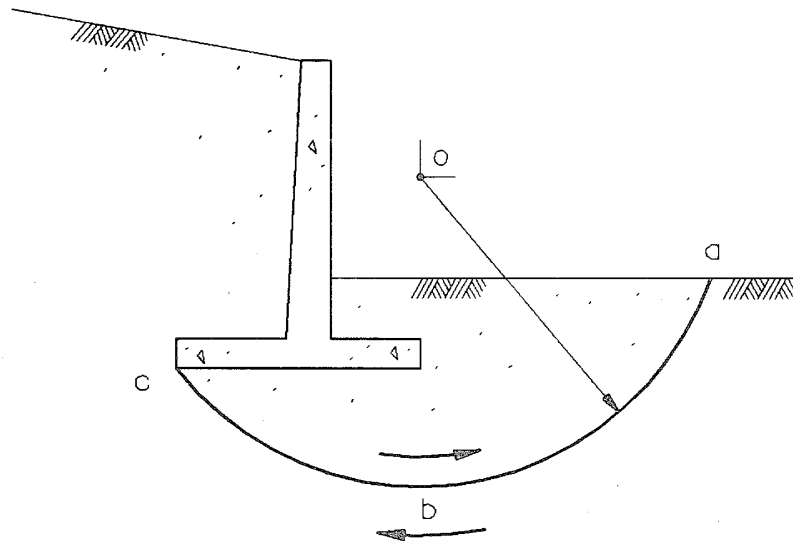

Figure 5-4. Shallow shear surface

5-13. Liquefaction Susceptibility. Where walls are underlain by sands below the water table in seismically active areas, an analysis should be made of the safety against foundation liquefaction. Flood walls in alluvial valleys are particularly likely to be situated over loose, saturated sands that may be liquefiable. A preliminary assessment of liquefaction susceptibility can be made using Seed's simplified method (Seed 1976, Seed and Idriss 1982) which is based on the standard penetration test. If the foundation is found to be non-liquefiable, no further analysis need be made. If liquefaction may occur, an assessment should be made of the risks and consequences of liquefaction failure and the benefits and costs of alleviating the risks. The occurrence of an earthquake during a flood is a case of the joint occurrence of independent rare events. For flood walls, the probability (risk) of an earthquake during a flood will be much smaller than the probability during a non-flood period, but the associated consequences may be much higher. For certain walls, (e.g., a low retaining wall remote from other structures) the probability of liquefaction failure and the related consequences may translate into such a small risk that accepting the risk may be the preferred alternative. Possible alternatives to dealing with potentially liquefiable foundations include:

- a. Changing the proposed location (usually the best alternative, where feasible).

EM 1110-2-2502

29 Sep 89

- b. Removing and replacing the liquefiable materials.
- c. Improving the liquefiable materials in place, by densification or grouting.
- d. Accepting the risks and consequences of liquefaction.

CHAPTER 6

DESIGN AND CONSTRUCTION DETAILS AND CAUSES OF UNSATISFACTORY PERFORMANCE

6-1. Foundation Preparation. Earth foundations should be properly compacted and should be clean and damp before concrete is placed. Rock foundations should be cleaned and given any other necessary treatment to ensure proper bond of concrete to rock. Some rock foundations, primarily shales, require a protective covering such as unreinforced concrete to protect them from deterioration after being exposed and before concrete placement, unless the final excavation can be performed close enough in time to the placement of the structural base slab. When a protective coating is used, it must be such as to ensure proper bond.

6-2. Concrete Materials. Consideration should be given to the materials that are economically available for a particular project. EM 1110-2-2000 describes concrete materials requirements; all options which are applicable to the work and which include available materials should be investigated. Concrete proportions should be selected to satisfy strength and durability requirements.

6-3. Constructability. The dimensions of the wall should be such that reinforcement and concrete can be properly placed. EM 1110-2-2000 provides guidance for concrete placement. Guide specifications CW 03301 and CW 03305 provide detail requirements for concrete placement. The top thickness of the stem for cantilever concrete walls over 8 feet high and for base slabs should be a minimum of 12 inches to facilitate concrete placement. Stems not over 8 feet high with one layer of vertical reinforcement may be 8 inches thick. The wall section should be designed for simplicity and maximum reuse of forms. Any construction constraints due to the location of the wall should be included in the design.

6-4. Joints. Walls are designed with joints to allow for expansion, contraction, and/or to divide the structure into convenient working units. The locations of all horizontal and vertical joints should be shown on the drawings.

a. Expansion Joints.

(1) General Needs and Uses. Expansion joints are designed to prevent the crushing and distortion (including displacement, buckling, and warping) of the abutting concrete structural units that might otherwise occur due to the transmission of compressive forces. Compressive forces may be developed by expansion, applied loads, or differential movements arising from the configuration of the structure or its settlement. In general, expansion joints are needed to prevent spalling and sometimes to break continuity. In relatively thin reinforced concrete walls such joints should be located where considerable expansion or unequal settlement is anticipated, e.g., at changes in alignment or grade, at abrupt changes in section or at intermediate points when needed. In massive reinforced concrete walls and in gravity walls on rock, expansion joints usually are not provided unless required at abrupt

29 Sep 89

changes in section or at angle monoliths to relieve thrust from expected expansion. Otherwise, adequate chamfers on each side of each contraction joint usually are sufficient to prevent spalling. Where temperature variations are extreme, modification of these criteria may be required. Reinforcing steel, corner protection angles, and other fixed metal embedded in or bonded to the surface of the concrete should not extend through an expansion joint. Where water tightness is needed, water stops are provided as outlined in paragraph 6-4e.

(2) Joint Filler. The thickness of joint filler necessary to provide stress relief at a joint should be determined from the estimated initial contraction and subsequent expansion from maximum temperature variation. Pre-molded expansion joint filler and adequate chamfers should be used.

b. Contraction (Monolith) Joints. These are intentional planes of weakness designed to regulate cracking that might otherwise occur due to the unavoidable, often unpredictable, contraction of concrete structural units. Contraction joints also divide the structure into convenient working units and thus also serve as construction joints. Since it is impractical and uneconomical to provide sufficient reinforcement to prevent cracks entirely, it is desirable to control their location, insofar as is practicable, by vertical contraction joints, across which reinforcement does not extend. No exact rules for the location of such joints can be made. Each job must be studied to determine where the joints should be placed, taking into account the requirements of structural design, the volume of concrete which can be placed economically in a single working unit, and the economical use of form units. Typically, contraction joints have been spaced 20 to 30 feet apart. Usually, a contraction joint has a plane surface without a key. For cantilever concrete walls, vertical contraction joints may be located only in the stem, and the footing may be a continuous placement.

c. Horizontal Construction Joints. These joints are provided to divide a wall into convenient working units, but they should be kept to a minimum. Keys are not permitted in horizontal construction joints as they interfere with good cleanup of the concrete surface and because a well-bonded flat surface is more dependable to transfer shear.

(1) Gravity Concrete Walls. For this type of wall the horizontal construction joint locations are dictated by the height of each lift of concrete placement. Concrete for gravity walls is usually placed in lifts up to 10 feet high. The top surface of each lift is cleaned and roughened by high-pressure water jets before placing the next lift.

(2) Cantilever Concrete Walls. For this type of wall a construction joint between the base and the wall stem should be provided. Additional horizontal joints in the wall stem should be provided by lifts approximately 10 feet high. The surface of each joint should be roughened to obtain as much shear strength across the joint as possible.

d. Joint Details for Flood Walls. For expansion and contraction joint details for flood walls, see paragraph 7-14.

e. Water Stops. Water stops are provided across joints where water-tightness is required. Nonmetallic water stops, such as rubber or polyvinyl chloride (PVC) water stops, should be used in accordance with EM 1110-2-2102. For special flood wall water stop details, see Chapter 7, Sections II and V. Careful inspection is required for water stop installation, especially with the type "U" water stop (Figure 7-9b), to see that special reinforcing is properly placed and that concrete is placed under the upper water stop in the base slab.

6-5. Soil Backfill.

a. Material Choice. Many types of material can be used for backfill. It is advisable to use locally available material when possible. Unusually poor foundation material or a need to control piping may require importation of select material.

b. Materials. Clean sands and gravels are the most suitable materials. They drain rapidly, are not susceptible to frost action, and remain stable. Silty sands, silts, and coarse-grained soils containing some clay are less desirable since they drain slowly, are subject to seasonal volume changes, and may lose much of their strength with time. Shrinkage cracks may develop in clay which, when filled with water, can cause full hydrostatic pressures to act on the wall. As mentioned in paragraph 6-7, clay, as backfill or foundation material, is involved in most retaining wall failures. During winter construction, frozen backfill material should not be used under any circumstances. This material may appear satisfactory when put into place, but it can be adversely affected when it thaws.

c. Placing and Compacting. (Refer to Chapter 3 and Appendix J for additional information on compaction.) The backfill material should be carefully selected. It should be compacted to prevent large settlements due to its own weight, with the amount of compaction required depending on the material used and the purpose of the structure. Very strict control of compaction is required when the fill is a cohesive soil. When granular fill is used, the material should be placed in thin lifts with each lift being compacted before the next lift is placed (see EM 1110-2-1911). However, precautions should be taken to prevent overcompaction which will cause excessive lateral forces to be applied on the structure. If heavy compaction rollers are used near the wall, their effect on lateral earth pressures on the wall should be considered in the design. Alternatively, the allowable weight of compactors may be restricted by the specifications to control wall pressures. It is good practice to place a layer of impervious soil that is a minimum of 12 inches thick in the upper lift of the backfill to reduce infiltration of rainwater. Backfill should be brought up equally on both sides until the lower side finished grade is reached.

6-6. Drainage.

a. Need for Drainage System. As mentioned in paragraph 6-7, improper drainage systems are one of the major causes of retaining wall failures. Drainage systems are necessary to eliminate excess hydrostatic pressures on the failure plane and the wall stem due to water seepage and surface infiltration of rainfall. In some cases the drainage system may be needed to prevent pressures from building up due to frost action in the backfill or to minimize pressures due to swelling of cohesive backfills. The kind of drainage system required depends upon the type of soil backfill, amount of rainfall, ground-water conditions, and potential frost action. Regardless of the drainage system used, the wall must have an adequate factor of safety assuming the drainage system is inoperative (see paragraph 3-23).

b. Drainage Control Methods. All retaining walls must have adequate surface drainage to dispose of surface water. As previously mentioned, a layer of impervious soil should be placed on top of the soil backfill to reduce surface infiltration of rainfall. The most effective way to control drainage within the soil backfill is an inclined drainage blanket with longitudinal drain as shown in Figure 6-1. The inclined drainage blanket will

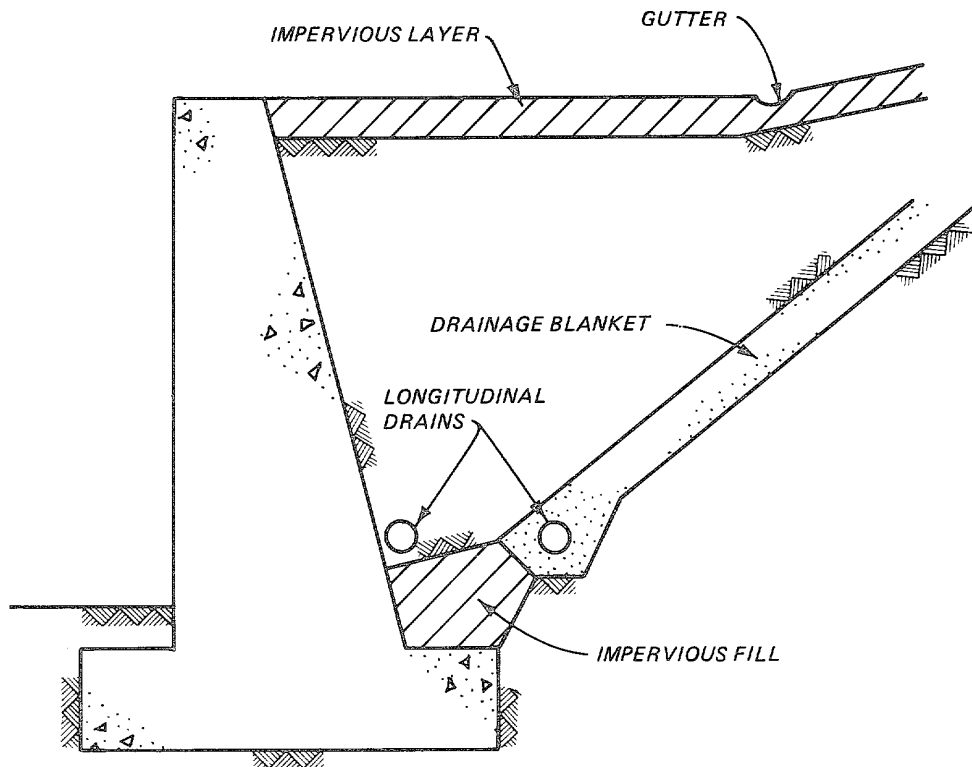

NOT TO SCALE

Figure 6-1. Inclined drainage blanket (after Department of the Navy 1982a)

minimize excess hydrostatic pressures on the failure plane due to groundwater seepage and surface infiltration of rainfall. A drain adjacent to the wall is less effective and will often result in higher loads against the wall (see Figure 6-2). However, for relatively low walls (typically less than 10 feet high), these higher loads may not be significant, and drains adjacent to the wall are often used. Drains adjacent to the wall may be either a drainage blanket (Figure 6-3) or a prefabricated drainage composite* (Figure 6-4). Where frost penetration is a problem, a drainage system as shown in Figure 6-5 should be used. If a cohesive soil backfill is used, a drainage system as shown in Figure 6-6 will prevent changes in moisture content of the clay and hence reduce cracking and swelling potential. Other seepage control methods are discussed in paragraph 7-4.

c. Longitudinal Drains. Longitudinal drains within drainage blankets are used for carrying the discharge from behind the retaining wall to a ditch, manhole, or other free exit. Drains should be large enough to carry the discharge and have adequate slope to provide sufficient velocity to remove sediment from the drain.** To minimize clogging, the drain should have perforations in the bottom half of the pipe at least 22.5 degrees below the horizontal axis. Where the operation of the drains is counted on to reduce the design loadings, manholes and/or inspection holes (see Figure 6-7) should be located at sufficient intervals, and at any sharp bends in the pipe, to facilitate inspection and cleanout. The terminus of the drain should have a vertical check valve (see Figure 6-8) to prevent backflooding. The end section of pipe supporting the check valve should be secured with a coupling band which can be removed for inspection and cleaning of the pipe.

d. Weepholes. Weepholes should consist of a pipe, at least 3 inches in diameter, extending through the stem of the wall. They should be protected against clogging by pockets of gravel in the soil backfill or by the use of filter fabric adjacent to the wall directly behind the weepholes. The weepholes are commonly spaced not more than 10 feet apart vertically and horizontally.

e. Filter Requirements. Drains should be adequately protected by filter layers so that seepage water is admitted freely but movement of the soil backfill into the drain will not occur. The piping or stability criterion is

* Whenever a prefabricated drainage composite is used adjacent to the retaining wall, the crushing strength of the prefabricated drainage composite should be greater than three times the maximum lateral earth pressure acting on the wall. Prefabricated drainage composites are not recommended for inclined drains due to possible damage during compaction of the soil backfill and possible sliding along the plane of the drain (Smith and Kraemer 1987, Kraemer and Smith 1986).

** For a 6-inch-diameter pipe the minimum slope would be about 0.15 percent (Schwab et al. 1981).

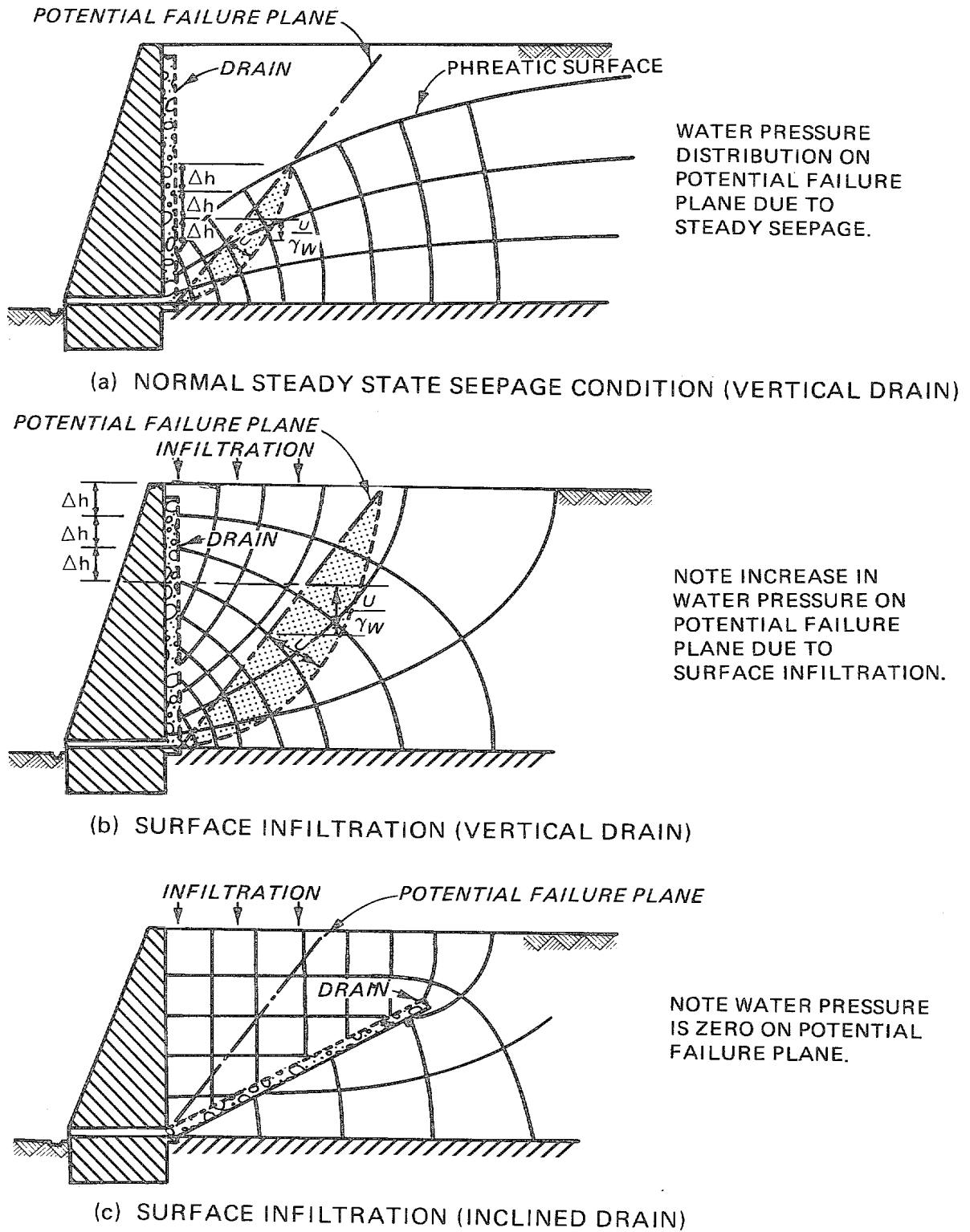

Figure 6-2. Effect of drain location on excess hydrostatic pressures on the failure plane (after Geotechnical Control Office 1982)

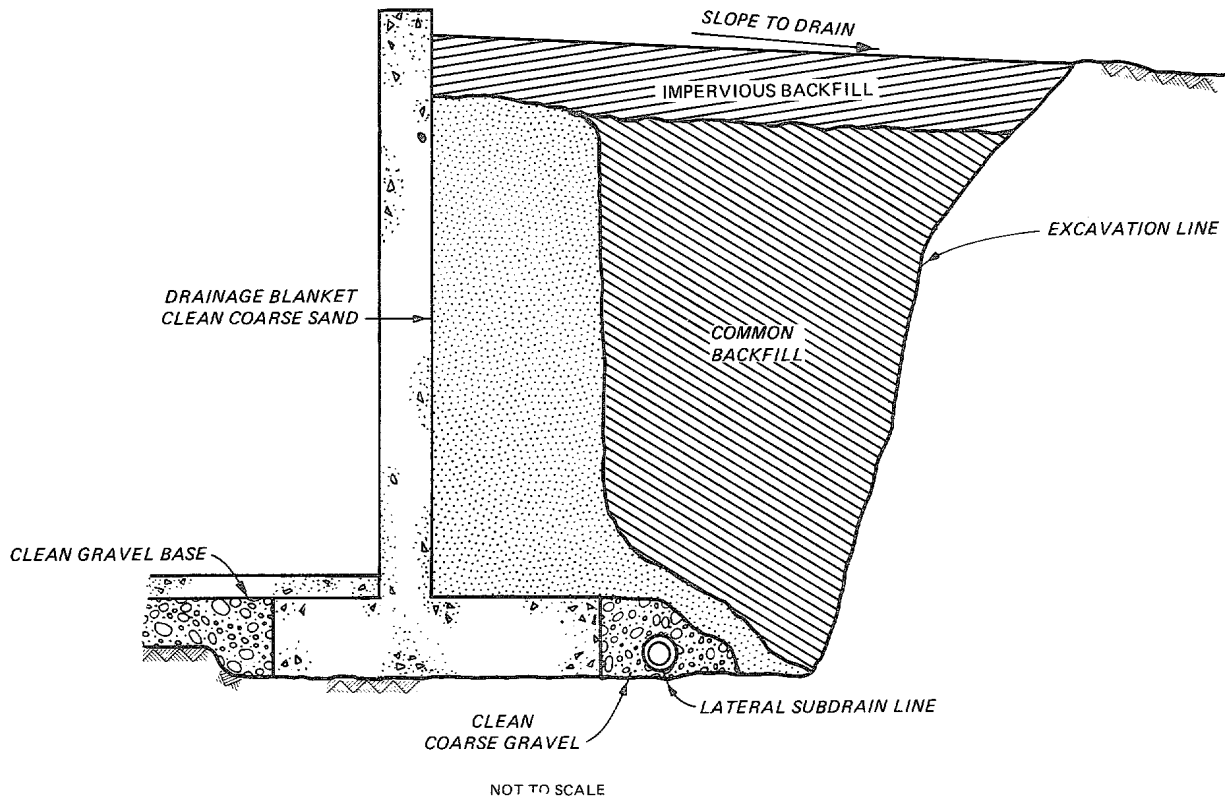

Figure 6-3. Drainage blanket located adjacent to retaining wall
(after Sibley 1967)

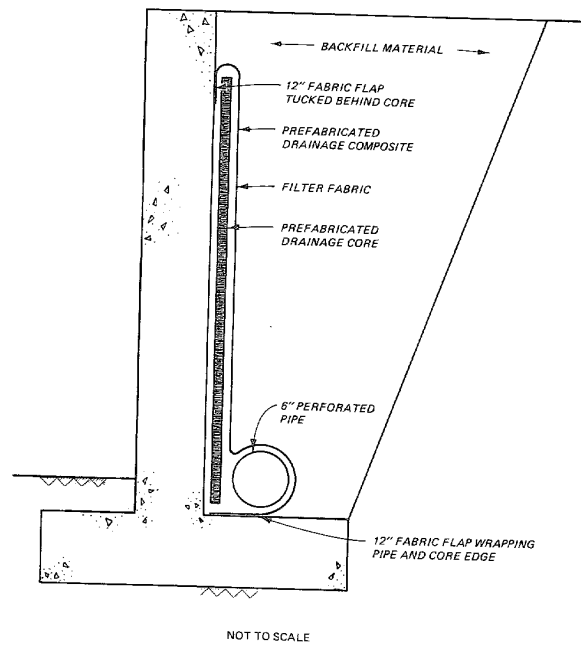

Figure 6-4. Prefabricated drainage composite used as drain adjacent to retaining wall (adapted from Carrol and Murphy 1985)

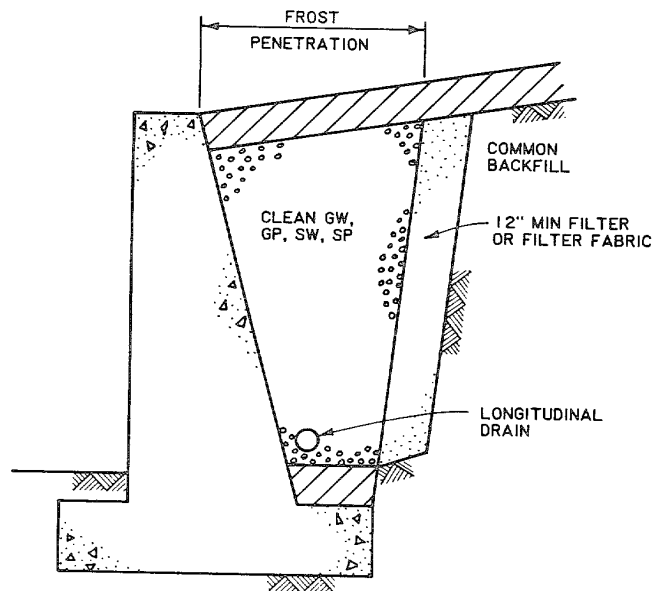
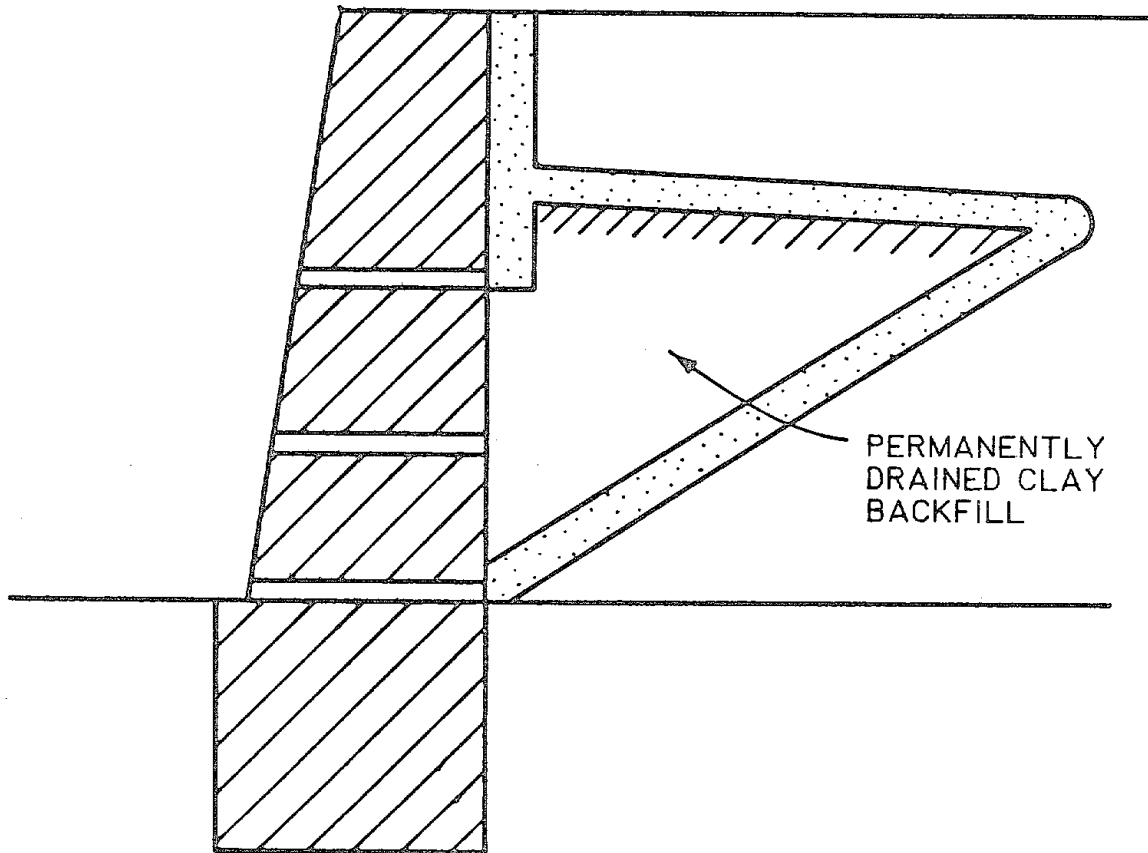

Figure 6-5. Drainage system to prevent frost penetration behind retaining wall (after Department of the Navy 1982a)



NOT TO SCALE

Figure 6-6. Drainage system to use with clay backfill
(after Terzaghi and Peck 1948)

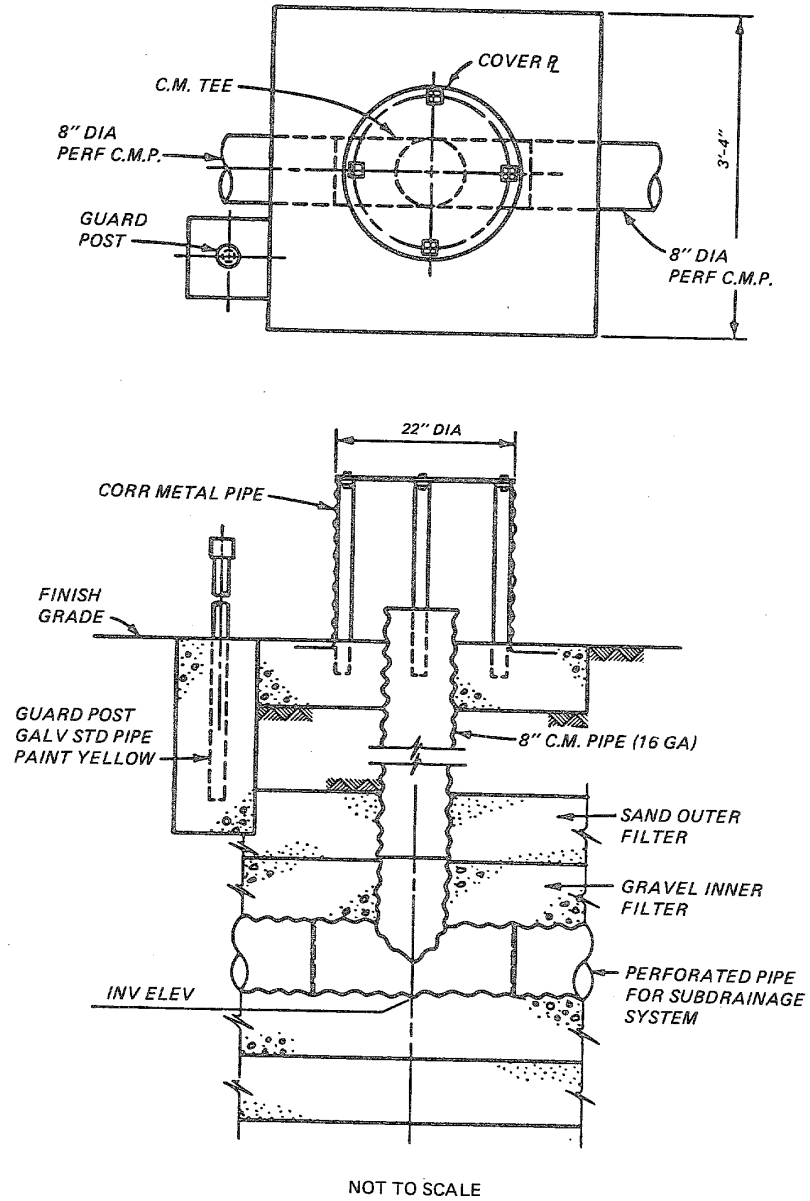
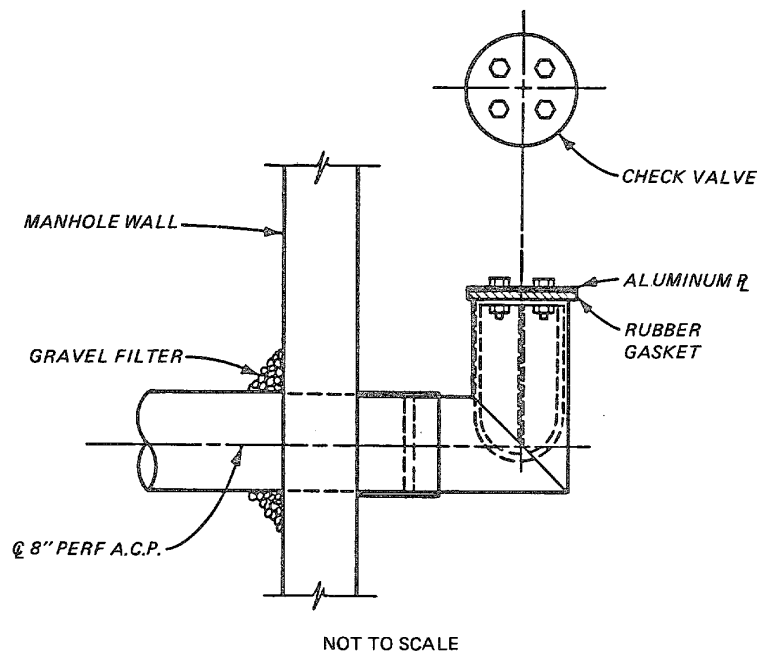

Figure 6-7. Inspection hole for longitudinal drain



TYPICAL VERTICAL CHECK VALVE SEAT

Figure 6-8. Vertical check valve at end of longitudinal drain

based on the grain size relationship between the protected soil and the filter

$$\frac{D_{15_F}}{D_{85_B}} \leq 5 \quad [6-1]$$

where

D_{15_F} = size of filter material at 15 percent passing

D_{85_B} = size of protected soil at 85 percent passing

and

$$\frac{D_{50F}}{D_{50B}} \leq 25 \quad [6-2]$$

where

D_{50F} = size of filter material at 50 percent passing

D_{50B} = size of protected soil at 50 percent passing

To assure that the filter material is more permeable than the material being drained, the following condition must be met:

$$\frac{D_{15F}}{D_{15B}} \geq 5 \quad [6-3]$$

To prevent clogging of perforated longitudinal drains, the following requirement must be satisfied:

Circular openings

$$\frac{D_{50F}}{\text{Hole diameter}} \geq 1.0 \quad [6-4]$$

Slotted openings

$$\frac{D_{50F}}{\text{Slot width}} \geq 1.2 \quad [6-5]$$

The filter material may satisfy the criteria for stability and permeability but may be too fine to meet the criteria for circular or slotted openings. Should this happen, multilayered or graded filters are required. It may be possible to substitute filter fabric for one or more of the granular filters in a multilayered filter system. Filter cloth shall conform to the

requirements of guide specification CW 02215.

f. Drain Requirements. The drain must be able to carry the design flow freely without movement of soil particles. Drainage blankets may be constructed of clean sand and gravel or a prefabricated drainage composite (for certain applications). The design flow can be determined from a flow net (Cedergren 1967). For isotropic soil conditions:

$$q_b = k_b h \frac{n_f}{n_d} \quad [6-6]$$

where

q_b = quantity of discharge through soil backfill per linear foot of retaining wall

k_b = permeability of soil backfill

h = hydrostatic head acting on retaining wall

n_f = number of flow channels in flow net

n_d = number of equipotential drops in flow net

The minimum required permeability of the drain is

$$k_d = \frac{q_d}{i_d A_d} \quad [6-7]$$

where

k_d = minimum required permeability of the drain

q_d = quantity of discharge through drainage blanket or prefabricated drainage composite per linear foot of retaining wall

i_d = gradient of flow in the drain (1 for vertical drain, equal to slope of drain for inclined drain)

A_d = cross-sectional flow area of drain

Seepage in coarse aggregates may be turbulent and a reduction factor should be applied to the permeability as shown in Figure 6-9. The in-place permeability

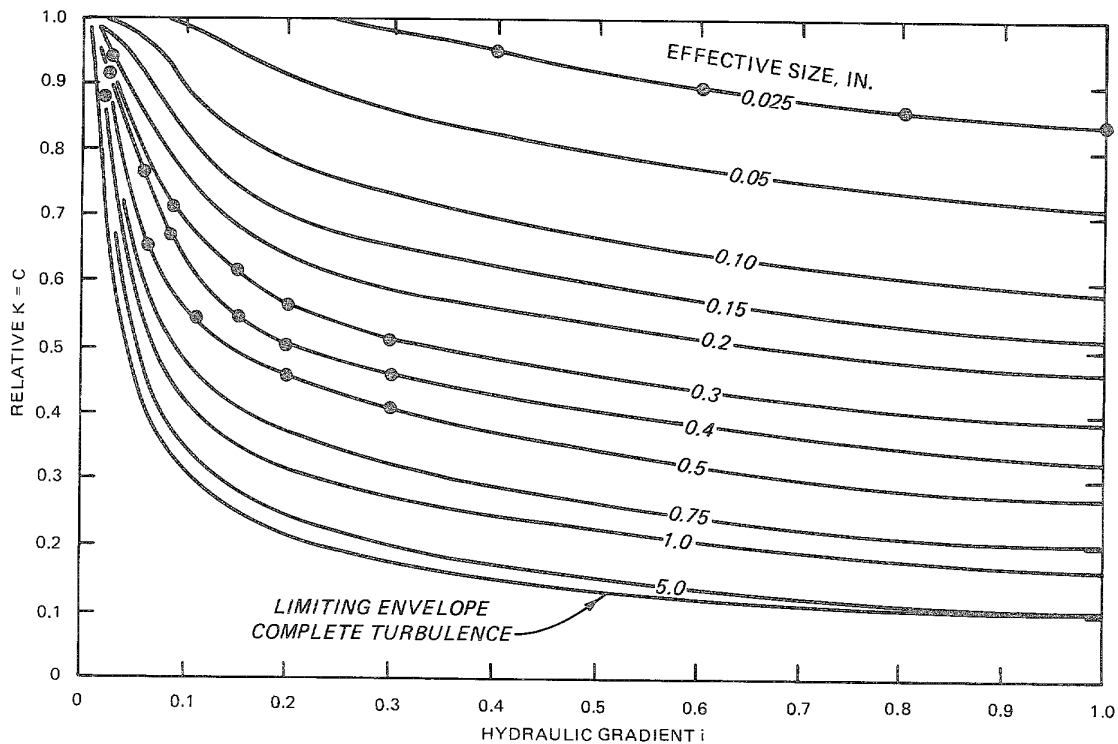

Figure 6-9. Approximation for estimating reduction in permeability of narrow size-ranged aggregate caused by turbulent flow (Cedergren 1967, courtesy of John Wiley and Sons)

should be at least 20 times that calculated theoretically. For prefabricated drainage composites the in-plane permeability will decrease with increase in lateral pressure. Therefore, the in-plane permeability must be taken at the maximum lateral earth pressure acting on the wall.

g. Construction Considerations.

(1) Sand and Gravel. Sand and gravel must not become segregated or contaminated prior to, during, or after installation. Segregation will result in zones of material too fine to meet the permeability requirements and other zones too coarse to meet the stability requirements. Contamination of the filter material from muddy water, dust, etc., during construction may clog the voids in the material and prevent proper drainage. In the event that filter or drain materials are contaminated, they should be replaced. Filter materials subject to cementation should be rejected.

(2) Prefabricated Drainage Composite. Special consideration should be given when compacting soil backfill near prefabricated drainage composites adjacent to retaining walls. Compaction adjacent to the retaining wall will induce high lateral pressures which could crush the prefabricated drainage

composite and/or reduce the inplane permeability. The drainage composite manufacture's recommendations for backfilling and compaction near the composite should be followed. A test section may be required to determine the acceptable operating conditions of the compaction equipment. Where crushed stone is used as the backfill material, a blanket of sand should be provided against the drainage composite to protect it against damage during compaction.

(3) Longitudinal Drains. One bad joint could render an entire drainage system inoperative. Care must be taken in compacting soil backfill over drains to prevent crushing of the pipe. Differential settlement can cause pipe joints to open up, permitting soil backfill to infiltrate. This should be minimized by attaining uniform adequate compaction of the underlying material.

6-7. Causes of Unsatisfactory Performance. The results of two statistical studies of retaining wall failures are given in Figure 6-10 (Tcheng and Iseux 1972, Ireland 1964). It is evident that:

a. Clay, as backfill or foundation material, is involved in most retaining wall failures.

b. Improper design of the drainage system and/or the wall base is the main cause of retaining wall failure.

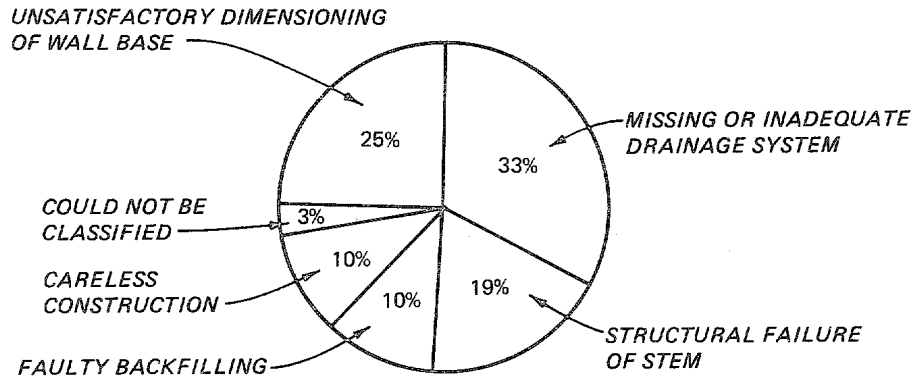

a. Causes of failure of rigid concrete retaining walls (Techeng and Iseux 1972)

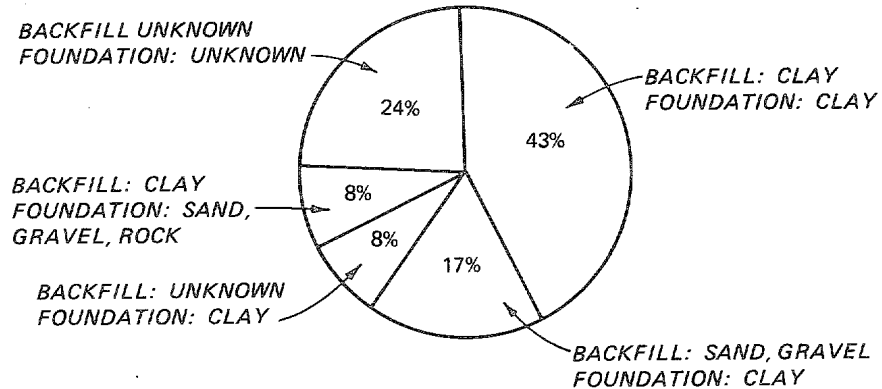

b. Foundation and backfill material of unsatisfactory retaining walls (Ireland 1964)

Figure 6-10. Summary of experience with unsatisfactory retaining walls

CHAPTER 7

SPECIAL CONSIDERATIONS FOR FLOOD WALLS

Section I. General Characteristics

7-1. Introduction. The principal function of a flood wall is to prevent flooding (inundation) of adjacent land. A flood wall is subject to hydraulic loading on one side which is resisted by little or no earth loading on the other side. The two principal types of flood walls are inland and coastal. Inland flood walls typically are installed along a riverbank and are subjected to design loadings (pool to freeboard line) for periods of hours or days (long-term loadings). Coastal flood walls are primarily subjected to short-term loadings (waves from hurricanes along with wind/tide high water surges). The wave loadings are dynamic in nature and act upon the structure for only a few seconds each. Concurrent high winds can prevent any emergency maintenance during a storm. Utility line crossings through a flood wall require careful attention to allow for independent movement of the utility lines and the wall, which requires special expansion joint details.

7-2. Rationale for Loading Cases.a. Design Water Level.

(1) The hydraulic data required for determining the design water level should be listed in the hydrologic/hydraulic appendix of the pertinent planning document for the project. The flow characteristics noted in historical records and indicated from detailed observation of existing conditions will usually be basic to the design of inland flood walls. Coastal flood walls will frequently require hurricane surge simulation studies and wave setup estimates. Wave overtopping can cause severe scour at or near the protected side of the stem. See paragraph 3-24 for information on surge and wave loads.

(2) Factors that influence the water surface profile and level of protection, and that can reasonably be quantified, are included in the design water level; not the freeboard. Some examples of these factors are:

(a) Changed conveyance, due to changing bed form, sedimentation or scour, and vegetation growth or removal.

(b) Dynamic surges, and super elevation.

(c) Ice, debris, and local anomalies.

(d) Transverse slope due to water flowing out of or into the channel or differences in velocity head between the channel and overbank locations.

(e) Profile instabilities associated with braids, meanders, etc.

(f) Energy losses due to changing flow area, e.g. constrictions (bridges), abrupt expansions, and bends.

(g) Future changes in flood flows due to changes in the watershed.

b. Freeboard. The freeboard is the marginal height of wall provided above the design water level. Freeboard is designed to accomplish design objectives and allow for uncertainty in a water surface profile.

(1) Examples of design objectives are:

(a) Assurance of initial overtopping at the most desirable (least hazardous) location.

(b) Reduced volume of wave overtopping.

(c) Extension of interval between major maintenance such as removal of sediment deposition.

(2) Freeboard allowances for water surface uncertainty are allowances that are not otherwise specifically accounted for because they are considered too small to require specific determination or because they are too intractable to be quantified. Those factors that influence the water surface profile, and level of protection, and that can reasonably be quantified are included in the design water level; not the freeboard.

(3) Wall settlement is identified as a separate increment added to the wall height for that purpose and is not included in the freeboard.

(4) Freeboard design should be refined as a study progresses and not left entirely to a detailed design phase. The amount of effort and corresponding refinement for a given phase is a function of the importance and cost of freeboard relative to the overall plan. For an early reconnaissance phase it will generally be satisfactory to use quickly estimated freeboard values of generally accepted default values. Default values of 2 feet on agricultural and 3 feet on urban flood walls have been generally accepted. As the study progresses, these early estimated or default values will be replaced by values arrived at by a design process.

(5) When large non-breaking waves are normal incident to the stem of the flood wall, the amount of freeboard will be determined by the amount of overtopping allowed. It is important to remember that such overtopping can cause significant scour on the protected (toe) side of the wall. This potential for scour can require rigid paving within a 20- to 30-foot area of the wall.

c. Loading Cases. For determining water and soil loads acting on flood walls, refer to Chapter 3. Section I of Chapter 4 discusses loading cases.

Section II. Seepage Control

7-3. General Considerations. Water-retaining structures are subject to through-seepage, underseepage, and seepage around their sides or ends. Seepage control is a primary consideration of flood wall design. Uncontrolled seepage may result in water pressures and uplift forces on the wall base in excess of design assumptions and consequent structural instability. Excessive porewater pressures in foundation materials near the landside toe of a wall may create "quick" conditions evidenced by sand boils or heaving. Emerging seepage may have sufficient velocity to move cohesionless foundation materials and erode the wall foundation (piping). Seepage control entails the design of measures to ensure that seepage pressures and velocities are maintained below tolerable values. Properly controlled seepage, even if quantities are large, presents no hazard. Since flood walls are often built in congested areas, it is often necessary to pump seepage out of the protected area. While the seepage quantity is often small compared to other sources, it is occasionally appropriate to consider seepage control measures for the purpose of reducing seepage quantities. Inadequate seepage control, as shown by one example in Figure 7-1, may jeopardize the stability of a flood wall. In flood walls, control of through-seepage is provided for by water stops (paragraph 7-13). Seepage around the wall is controlled by specially designed and constructed levee wrap-around sections (paragraph 7-12). Flood walls are usually provided with a toe drain to control local underseepage along the flood wall base, as shown in Figure 7-2. As flood walls are usually founded on alluvial materials, pervious zones of significant thickness are often present at some depth below relatively impervious top stratum materials and may be hydraulically connected to the river. Because of the horizontal stratification of alluvial deposits, the horizontal permeability may be greatly in excess of the vertical permeability. The combination of these conditions may allow seepage to be readily conducted landward beneath the flood wall. Where flood walls are underlain by such pervious strata (the usual case), analysis may indicate the need for underseepage controls in addition to the toe drain. Underseepage control measures vary because the selection and design of an appropriate control scheme is highly dependent on site-specific conditions, particularly the stratification and permeability of foundation materials, availability of right-of-way, and local construction practices and costs. Various types of underseepage control measures are discussed in paragraph 7-4.

7-4. Underseepage Control. The focus of underseepage analysis is to calculate the expected exit gradient at the landside toe of a levee or flood wall and compare its value to a theoretically critical value, the critical gradient (typically 0.8 to 1.0). To provide some conservatism, underseepage controls are provided where the calculated gradient exceeds an allowable gradient, typically 0.5 to 0.8. For calculating the exit gradient, assessing the need for underseepage controls, and designing such controls, the foundation conditions are normally assumed to be a two-layer system consisting of a relatively impervious top stratum overlying a pervious substratum. Detailed analysis

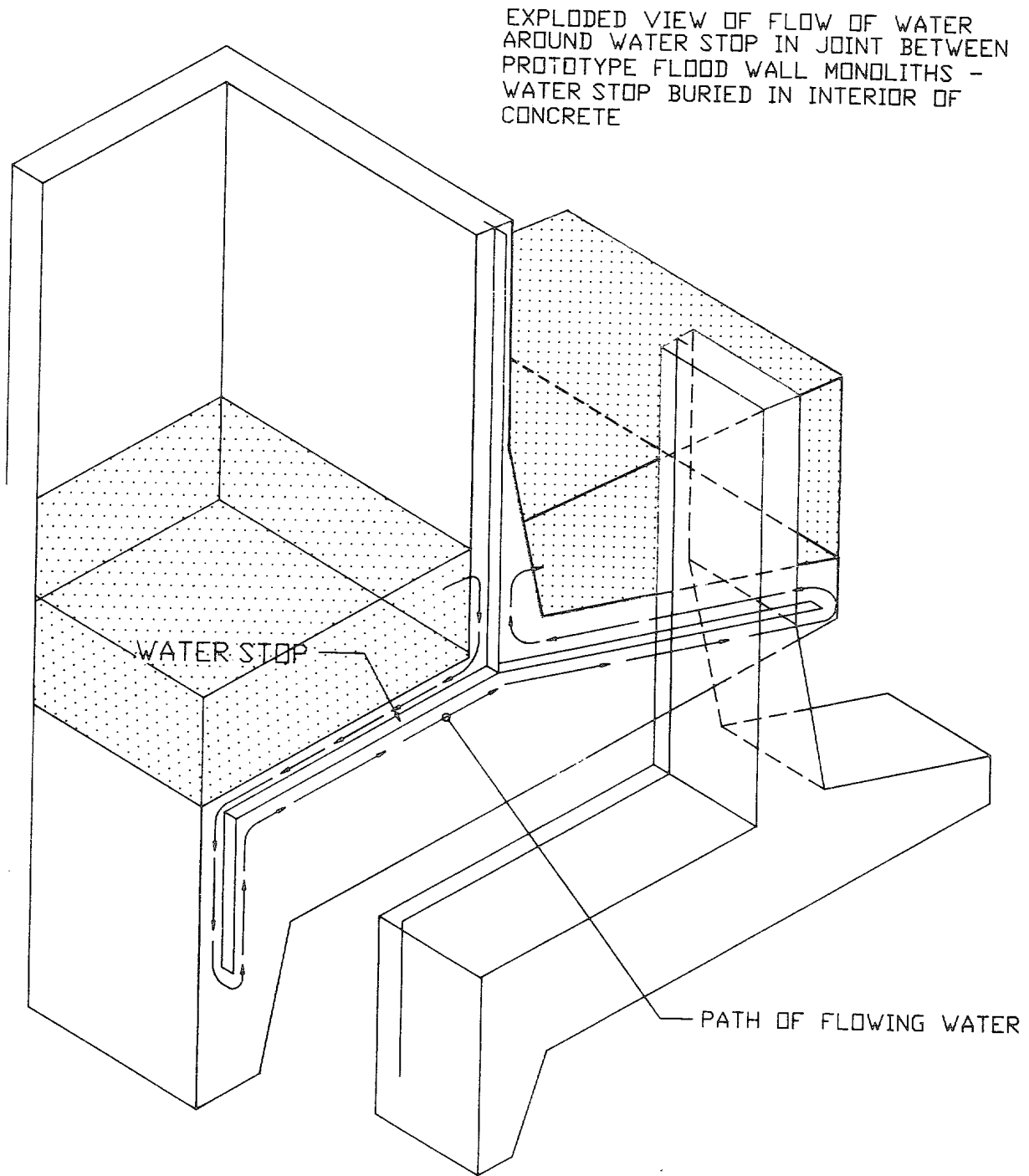

Figure 7-1. Flow around interior embedded water stop in the base

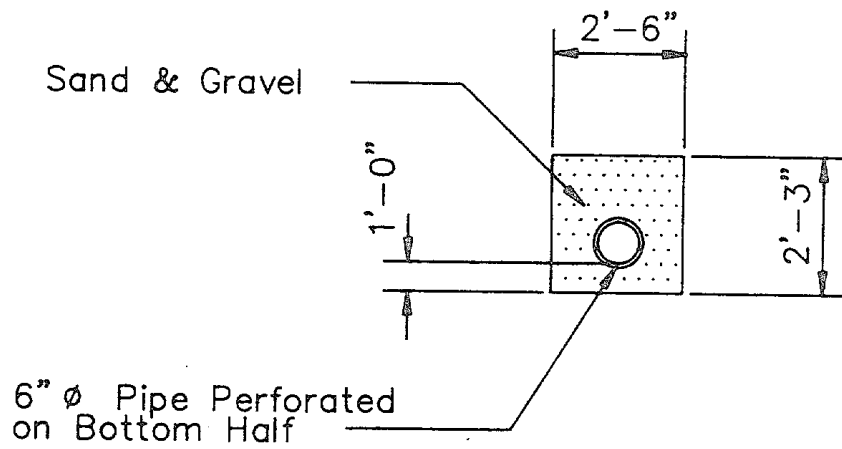
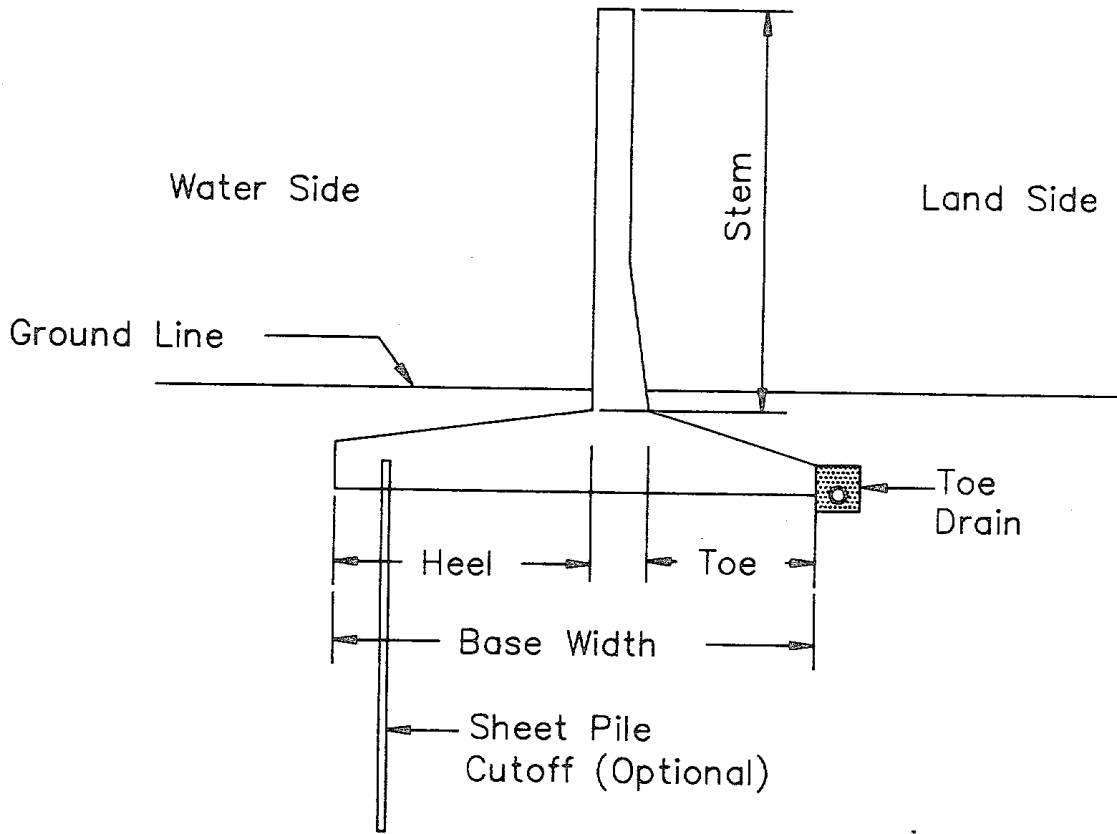

Figure 7-2. T-type flood wall--horizontal base

29 Sep 89

procedures are contained in EM 1110-2-1913 and WES Technical Memorandum 3-424 (US Army Engineer Waterways Experiment Station, 1956). In some instances, where complex problems of geometry, anisotropy, and foundation layering exist, flow nets and/or finite element seepage analyses may be necessary. Types of underseepage control measures are described in the following paragraphs. Additional discussion is given in paragraphs 3-23 and 6-6.

a. Cutoffs. A cutoff penetrating the pervious stratum beneath the wall is the most positive means of controlling seepage. A cutoff can consist of an excavated trench backfilled with impervious compacted earth, a slurry trench, an extension of a concrete shear key, or a sheet pile wall. A cutoff is usually located at the end of the wall footing on the unprotected (heel) side. A cutoff must penetrate approximately 95 percent or more of the pervious strata before significant reductions in the quantity of flow can be realized; however, partial cutoffs can be somewhat effective in reducing uplift pressures on the wall base. Deep cutoffs will often interfere with the normal exchange of groundwater between an aquifer and a river during non-flood periods and should only be considered where detailed hydrogeologic studies have been made in this regard. The decision as to the type and depth of a cutoff should be based on an underseepage analysis considering actual site conditions. A steel sheet pile cutoff is not entirely watertight due to leakage at the interlocks but can significantly reduce the possibility of piping of coarse-grained material in the foundation. The effectiveness of a properly interlocked steel sheet pile cutoff through a coarse-grained stratum in reducing uplift can be assumed to be up to 50 percent. The design uplift diagram, as shown in Figure 7-3, should be drawn with a pressure head at point B on the unprotected side of the the cutoff equal to the full head of water on the unprotected side (neglecting any reduction in pressure due to head loss from seepage effects). The pressure head on the protected side of the cutoff at point B should equal the pressure at point B reduced by up to 50 percent of the difference between the full head value on the unprotected side and the pressure head at the end of the toe of the wall. The pressure head at the toe of the wall can be computed based on the seepage path from the cutoff wall to the saturated level on the protected side. If the effectiveness of the steel sheet pile cutoff is assumed to be greater than 50 percent, it should be based on actual experience of similar conditions and justified accordingly. An example of a flood wall with a sheet pile cutoff is shown in example 5 of Appendix N. A sheet pile cutoff is less effective in fine-grained material than in coarse-grained material because cohesion may allow cracking and separation of the soil away from the sheet pile. Bearing value of steel sheet piling should be neglected.

b. Toe Drains. All inland flood walls should be provided with a land-side toe drain similar to that shown in Figure 7-2. Coastal flood walls should be analyzed to determine if such drains are needed. The toe drain, which runs parallel to the wall at the landside edge of the footing, provides a positive outlet for local underseepage and a check for controlling piping and/or excessive uplift pressure beneath the base slab. For walls on impervious foundations, the toe drain may be adequate to control all underseepage; for walls on pervious foundations, additional seepage control measures will

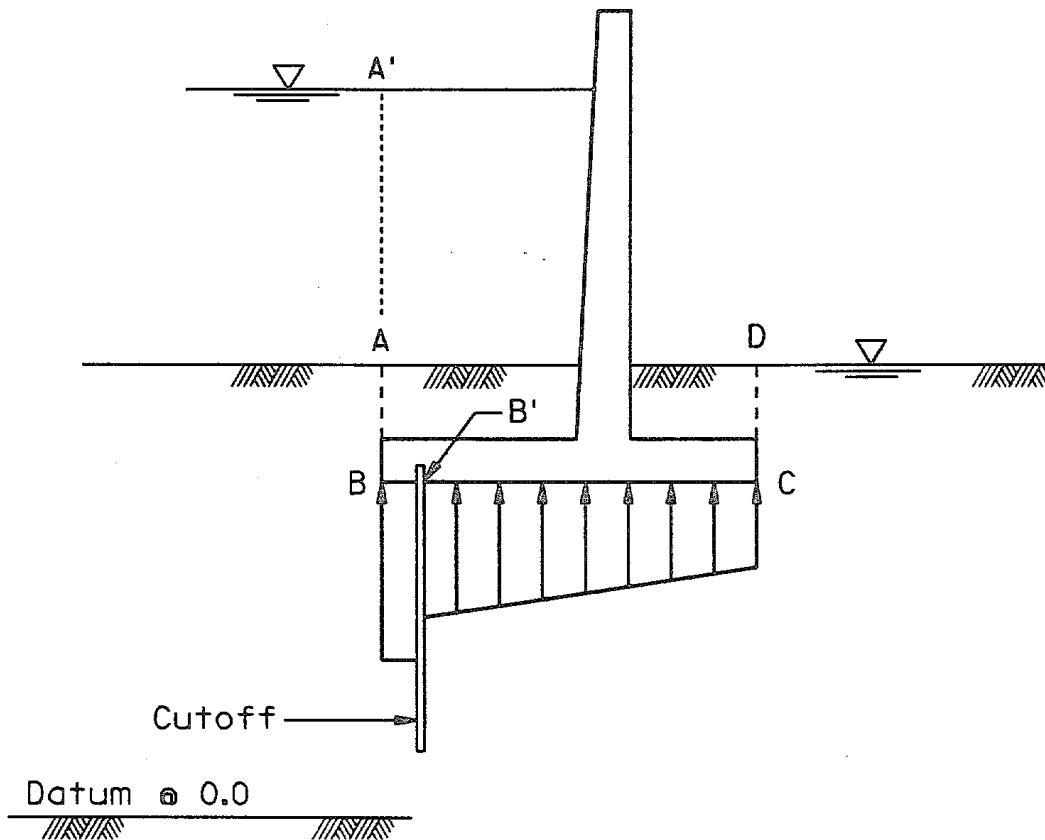

$$\text{Total head at B} = El_{A'}$$

$$\text{Pressure head at B} = El_{A'} - El_B$$

$$\text{Pressure head at B'} = (El_{A'} - El_B) - 0.5 [(\text{Pressure head at B}) - (\text{Pressure head at C})]$$

$$\text{Total head at C} = El_D + \left[\frac{DC}{DCB'} \right] (El_{A'} - El_D)$$

$$\text{Pressure head at C} = \text{Total head at C} - El_C$$

Figure 7-3. Uplift pressures for a wall with a sheet pile cutoff

29 Sep 89

usually be required. In the case of pile-founded walls, the toe drain should be adequate to protect against "roofing," the loss of material from beneath the wall base. The drain should never be located under the wall footing, in order to allow maintenance access and to avoid crushing the drain. A typical toe drain design will consist of a 6- to 8-inch-diameter pipe perforated on the bottom half and surrounded in all directions with 6 to 10 inches of filter material designed by the filter criteria in paragraph 6-6e. The collected water is usually disposed of by gravity outlets into ditches, ponding areas, or pump stations. The toe drain system should provide access for inspection and maintenance at changes in alignment and at intervals not to exceed 500 feet. Discharge pipes should be provided with check valves that will prevent the entrance of surface water.

c. Trench Drains. Where the impervious top stratum is thin or non-existent, a trench drain may be used to control underseepage in the vicinity of the flood wall toe. A trench drain is an enlarged variation of a toe drain. It extends from the ground surface through shallow pervious layers or into a pervious layer underlying a shallow surface blanket. The practical depth for construction of a trench drain depends on available excavation equipment and site dewatering requirements. The excavation, pipeplacement, and backfilling of the trench should always be performed in the dry. To assure adequate capacity, the collector pipe should be sized considerably larger than computations indicate to be necessary. Backfill in a trench drain should conform to the filter criteria in paragraph 6-6e. A trench drain should be provided with inspection and maintenance access and backflow protection as described for toe drains. The seepage calculations for the quantity of flow should assume the tailwater elevation equal to that of the discharge of the trench drain. However, if water can pond on the landside of the wall, the calculations for uplift pressure should check whether a more critical uplift condition can occur for the ponded case.

d. Relief Wells. Pressure relief wells are used to reduce uplift pressures at depths in pervious layers which might otherwise cause sand boils and piping of foundation materials. Wells function to some extent as a controlled sand boil, relieving pressure by discharging water, but retaining materials with a screen and filter. Wells are advantageous where pervious strata are relatively thick or relatively deep. They are particularly useful in controlling large quantities of seepage in strata of pervious material having direct connections with the river. Another advantage of relief wells is the ease with which they can be constructed if piezometric pressures measured during high water indicate the need for additional underseepage control. Design of relief well systems is described in EM 1110-2-1905, EM 1110-2-1901, and WES Technical Memorandum 3-424 (US Army Engineer Waterways Experiment Station, 1956). The design entails selecting a spacing, size, and penetration for a line of wells that will result in acceptable gradients at points midway between the line of wells and at the flood wall toe. Relief wells are usually not very effective in intercepting near-surface seepage, and it is often wise to use them in combination with a toe drain. Relief wells should be pump-tested when installed. Because the efficiency of relief wells may deteriorate with time due to corrosion or bacterial incrustation, considerable monitoring

and maintenance may be required to assure that the relief well system performs acceptably for the project life. To assess possible well deterioration, a representative number of wells should be periodically pump-tested, and the specific capacity (flow/drawdown) should be compared to the initial pump test results. To calculate uplift pressures on the wall, the potential head at the well line should be assumed equal to the average head in the plane of wells, a value obtained as part of the well design procedure in the cited references.

e. Riverside Impervious Blankets. Impervious riverside blankets (natural or constructed) overlying a pervious foundation are effective in reducing the quantity of seepage and to some extent are effective in reducing uplift pressures and gradients landside of the flood wall. Their effects may be analyzed using seepage analysis methods found in EM 1110-2-1913 and WES Technical Memorandum 3-424 (US Army Engineer Waterways Experiment Station, 1956). Riverside blankets may be constructed over thin natural impervious blankets to improve the effects of the natural blankets or they may be constructed directly on pervious material. Excessively steep riverbanks may make blanket construction impractical. Also, it is seldom feasible to construct blankets over exposed portions of the pervious layer under water. A noncontinuous blanket has serious drawbacks, as only a small area of pervious stratum left exposed may significantly reduce the blanket's effectiveness. Riverside impervious blankets need to overlap the riverside base of the flood wall to minimize the potential for rupture of the blanket by landward deflection of the flood wall when loaded. Riverside impervious blankets may be subject to scour at high river stages when they would be most needed, or may crack open if not continuously wet. To prevent such action, blankets should be protected immediately after construction. A well-designed and well-planted vegetative cover is ordinarily sufficient along straight reaches. Along outside curves of the river, the blankets should be protected with riprap or other positive protection.

f. Landside Seepage Berms. Landside seepage berms function by providing an increased landside top blanket thickness, thereby reducing the gradient. The berm also extends the seepage path by forcing the seepage exit landward. Seepage berms are typically 100 to 300 feet wide. As flood walls are usually built in areas where right-of-way cost or availability is insufficient for levee construction, seepage berms are rarely used in conjunction with flood walls. Procedures for seepage berm design are presented in WES Technical Memorandum 3-424 (US Army Engineer Waterways Experiment Station, 1956) and EM 1110-2-1913.

g. Grouting of Open Rock Joints. In cases where rock is shallow enough that flood walls can be founded directly on the rock, close examination of the rock surface is necessary to determine if open joints are present. Such joints can be detrimental to underseepage control and should be cleaned out and filled with grout before the concrete base is placed. If the possibility exists for seepage flow through porous or cavernous rock in the foundation, consideration should be given to installing a grout curtain.

Section III. Foundation Considerations

7-5. Base Types. The T-wall is the most widely used flood wall type. T-walls are normally constructed with horizontal or sloped bases. The advantages of each type of base are as follows:

a. Horizontal Base (Figure 7-2).

(1) The volume of foundation excavation is usually less for a horizontal base and it is simpler to construct.

(2) Bearing values and base pressures for the two base types are not directly comparable. However, for equal heights, base pressures of the horizontal base generally are smaller because of its reduced earth load and slightly wider base.

b. Sloped Base (Figure 7-4).

(1) A sloped base may allow shortening or complete elimination of a key, thereby reducing excavation difficulties. Also, a shorter key will generate less moment in the heel adjacent to the key and will generally allow for a shorter base width to maintain overturning equilibrium.

(2) The deep cover or blanket over the heel of a sloped base lessens the chance of rupturing the cover as the wall moves under load.

(3) The resultant of applied forces is more nearly normal to a sloped base, thereby reducing the tendency of the structure to slide along that plane.

(4) A full-size flood wall test performed by the Ohio River Division (1948-1956) (U. S. Army Engineer Division, Ohio River 1958) indicated that the sloped-base wall moved consistently less than the horizontal-base wall of comparable design.

c. Selection. Both base types have their advantages and disadvantages. Final selection will depend upon the specific site conditions at the project under consideration.

7-6. Horizontal Water and Earth Loads on Keys. For flood walls on clay foundations, full flood head will be conservatively assumed to act at the bottom of the key and the horizontal water load acting on the riverside face of the key will be computed on this basis. The seepage path will then be assumed to begin at the bottom of the key. The landside face of the key will normally be assumed to be in full contact with the earth-resisting movement of the wall.

7-7. Unsuitable Foundation Material and Bank Stability. Foundation material found to be unsuitable may be avoided by a change in alignment or may be removed and replaced with suitable earth fill (Figure 7-5). The wall may also

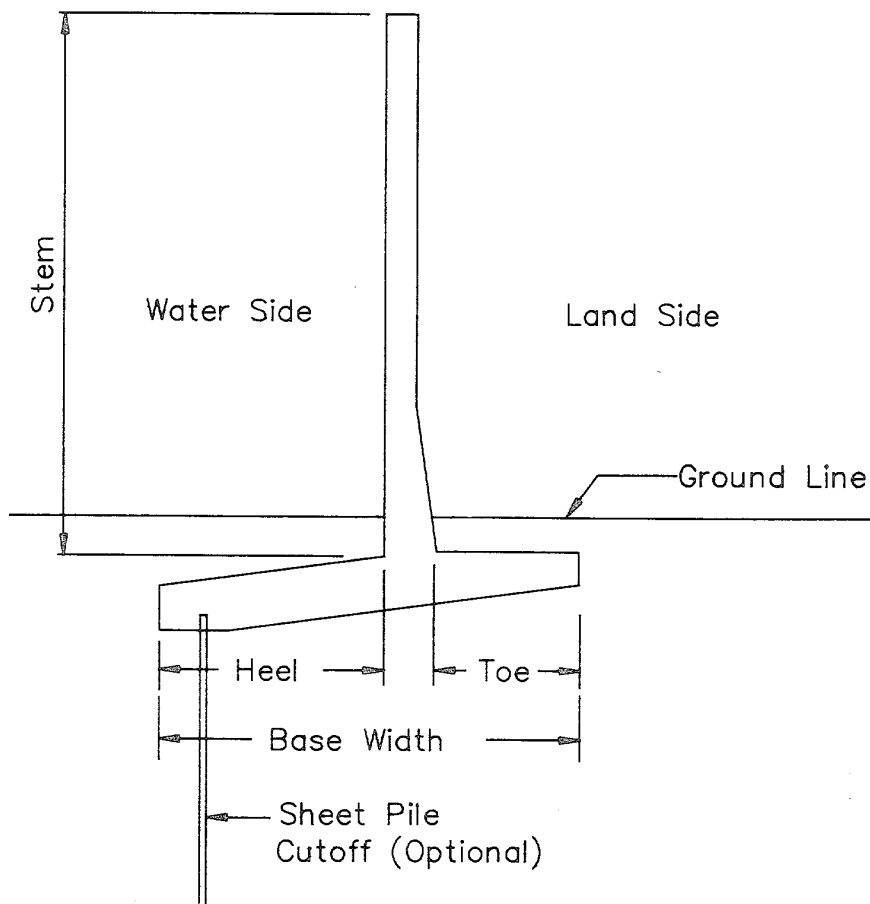
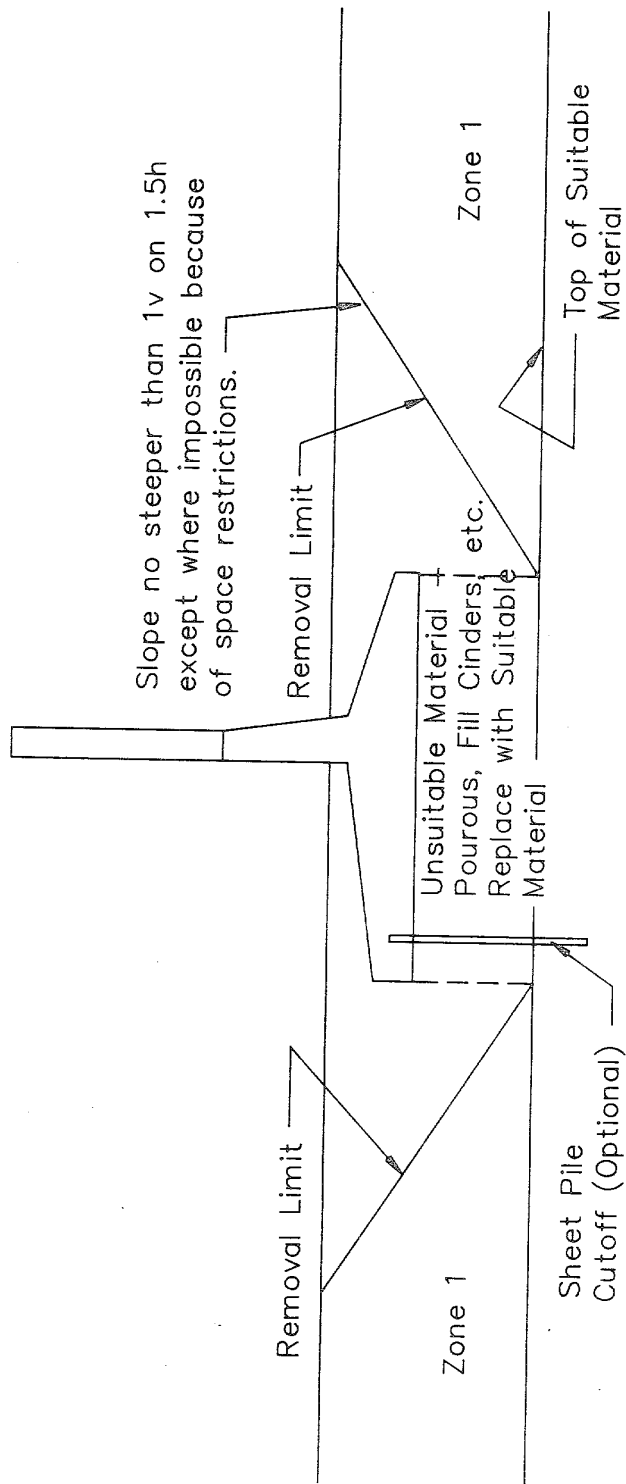

Figure 7-4. T-type flood wall--sloped base

be founded on piles through the unsuitable material. In some cases the removal of unsuitable foundation material involves the removal of or cutting into the existing riverbank on which the flood wall is to be placed. In other cases the right-of-way may be so restricted and confining that the flood wall may have to be placed near the top edge of the bank or even riverward of the bank. In those cases, fill placed riverward of the top bank is permitted, if proper precautionary measures are taken. Careful attention must be paid to the outlining of and removal of unsatisfactory material and to the selection of suitable replacement material. New material must be obtained, placed, and compacted to provide adequate support for the flood wall. Replacement material should undergo the same types of laboratory testing as existing foundation material. Placement and compaction techniques should generally be in accordance with earth dam and levee requirements. Slopes steeper than 1.0V on 1.5H and areas that require hand compaction should be minimized. Slopes on which there is evidence of past instability, or in which fill is a component,



Zone 2 - Suitable Foundation Material

Figure 7-5. Removal limits of unsuitable foundation material

should be investigated for stability. All riverward slopes should be checked for stability if the failure of the bank would jeopardize the stability of the wall.

7-8. Scour Protection. Occasionally a flood wall is exposed to scouring because of the direction, curvature, and velocity of current or waves, characteristics of the soil, topography, etc. Scouring at the wall footing should be considered, and where anticipated, protected with riprap. Design guidance on sizing riprap is given in EM 1110-2-1601.

Section IV. Types of Monoliths

7-9. Change-of-Alignment Monoliths. Changes in alignment require special monoliths (Figure 7-6). Monoliths with less than a 10-degree change (horizontal) do not need to be analyzed as a special category. Monoliths of short length or abrupt alignment changes may require very wide bases. A 90-degree corner monolith is an indeterminate structure. Adjacent monoliths should not be considered to provide resistance in the stability analysis.

7-10. Closure and Abutment Monoliths. A number of openings must be provided in many flood walls. The openings provide access for commerce, safety, and recreation during periods of low river stages. The number and size of openings depend on local requirements. Each opening must be provided with a moveable closure structure. During flood periods, the closure structure is installed on base and abutment monoliths (this combination is a special monolith). These special monoliths must be designed both for the design water load at high water and traffic loads during low-water periods.

7-11. Drainage Structure Monoliths. When topography, foundation conditions, and economics permit, it is preferable that structures housing gates and pumps be designed as integral parts of the flood wall. These special monoliths must be designed to minimize differential settlement across a monolith or between adjacent monoliths. For closure gate requirements and the need for secondary closure gates for drainage outlets, see EM 1110-2-1410.

7-12. Transition Sections Between Flood Walls and Levees.

a. Junctures. A junction between a T-wall and levee is not made directly or abruptly, but with a short transition concrete-capped sheet piling I-wall between the two (Figures 7-7 and 7-8). One of the primary concepts in the development of this transition is to arrange details so there will be a minimum amount of differential movement of joints of monoliths in the transition. The levee end of the transition will usually settle a considerable amount, due primarily to foundation consolidation under the added weight of the levee. The T-wall monolith immediately adjacent to the beginning of the levee adds far less superimposed weight on the foundation. Hence, there is much less settlement at this end of the transition. The I-wall can be satisfactorily adopted as a transition section between levee and T-wall because this type of construction can, and in fact must, be done after completion of the levee. A delay in inserting the I-wall allows for settling of the levee,

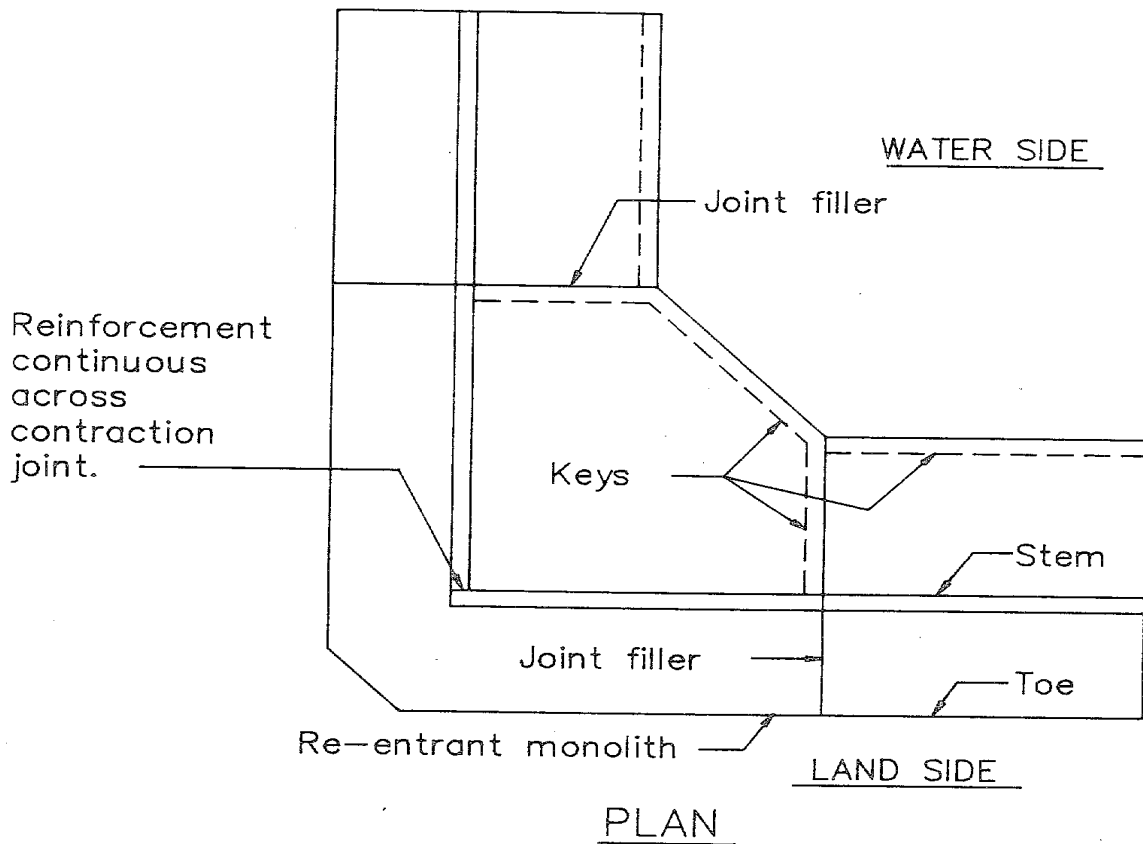
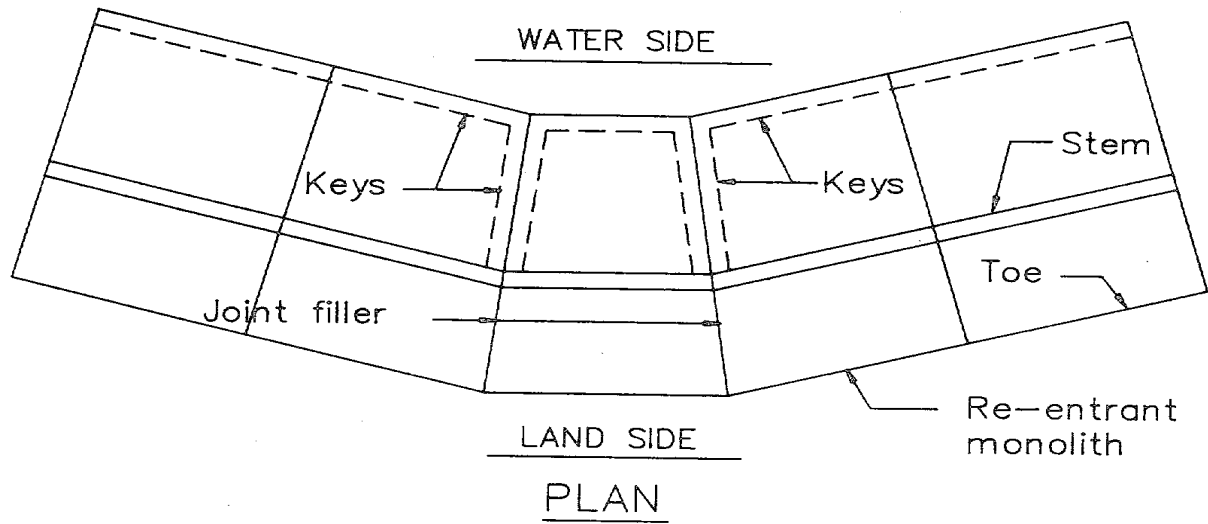

Expansion joint material (paragraph 7-14a) to be used where each end of re-entrant monolith touches the adjacent monoliths (see Figure 7-9a).

Figure 7-6. Return keys on reentrant monolith

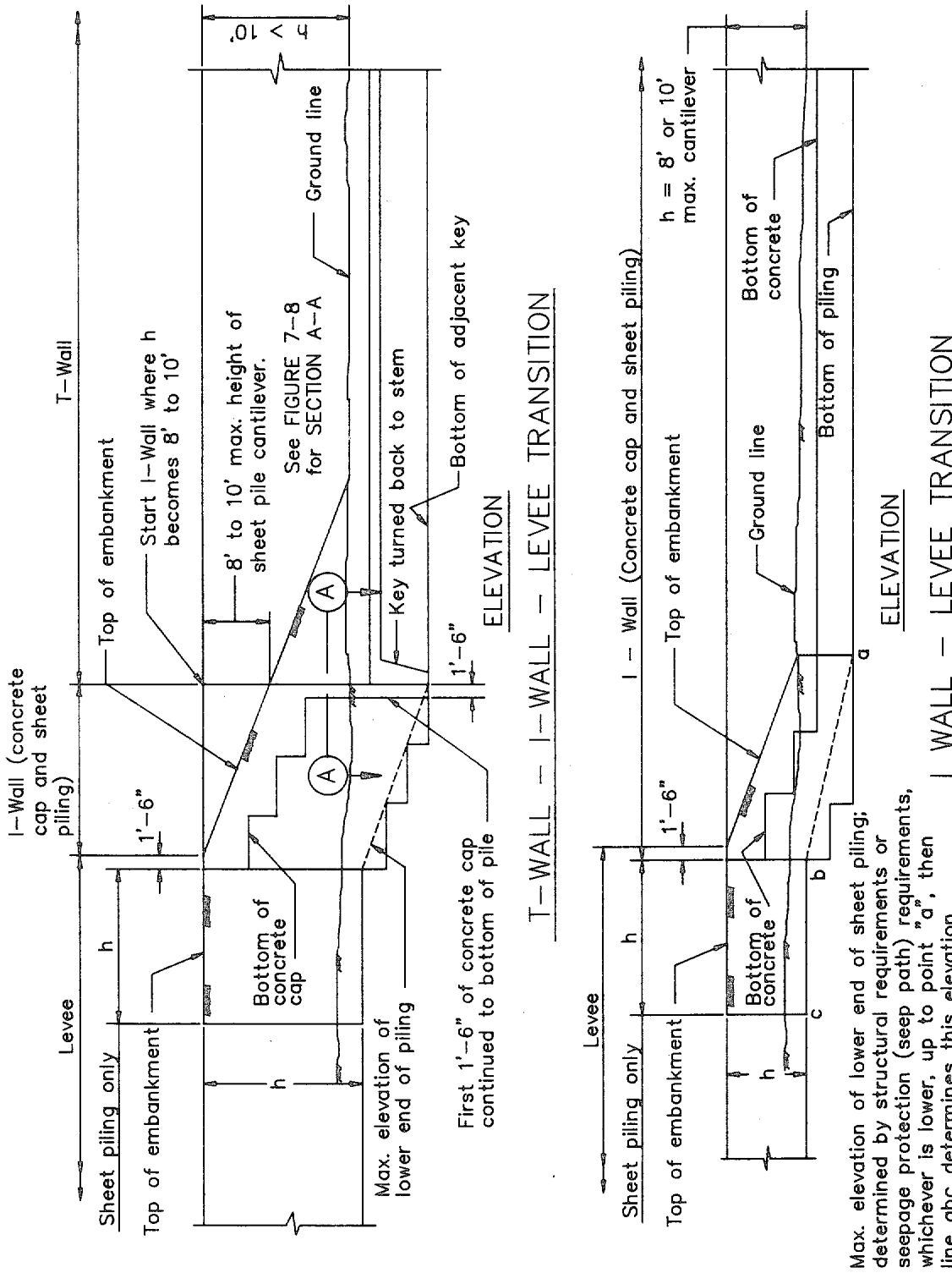
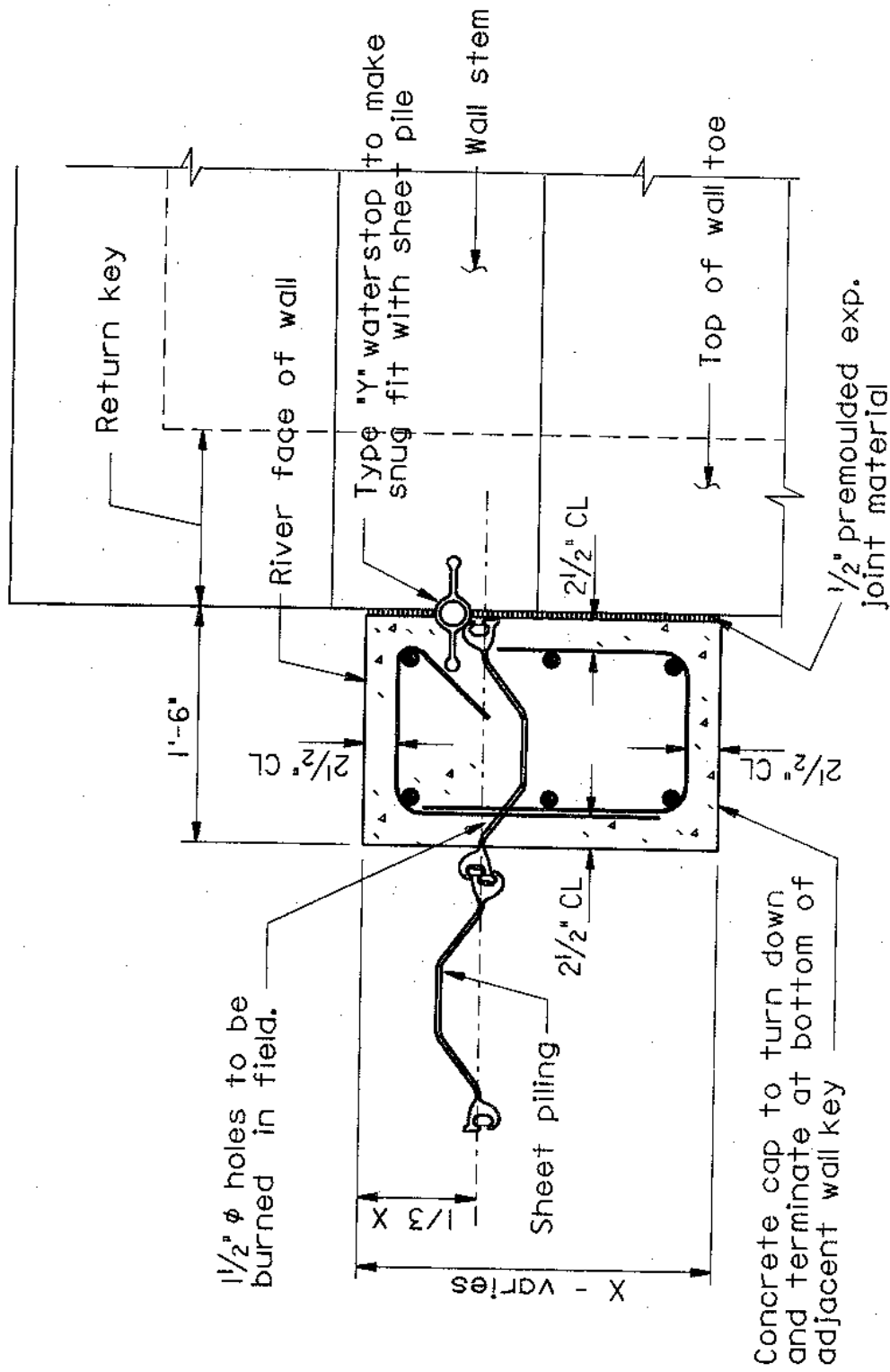

Figure 7-7. Flood wall-levee transitions



Note:
 For location of section A-A,
 see Figure 7-7.

Figure 7-8. Typical detail of joint between I-wall and T-wall

thus lessening the differential settlement between the levee end of the transition and the T-wall. Review by hydraulic engineers is required for inland flood walls to assure that the transition geometry will not create significant flow disturbance with consequent scour.

b. I-wall. The I-wall portion of the transition is begun where the levee slope (parallel to the protection) reaches a point 10 feet below the top of the wall. In cases where protection is already 10 feet or less above the levee, an I-wall, if used, is merely continued into the levee as shown in Figure 7-7.

c. Sheet Piling. It should be noted in Figure 7-7 that the sheet piling is continued into the levee for a specified distance beyond the last concrete cap.

Section V. Water Stops and Joints

7-13. Water Stops. As shown in Figure 7-9a, b, and c, for yielding foundations a U-shaped (type "U") water stop should enclose almost the entire base and a center bulb (type "Y") water stop, located in the stem, is joined to the U-shaped water stop at the bottom of the stem. Experience has shown that a center bulb or dumbbell water stop located within the base section is likely to allow excessive seepage. Between monoliths on a foundation requiring a cutoff, the type Y water stop in the stem should be extended to tie into the cutoff, and the type U water stop around the base should be deleted. The earth surface on which a type U water stop is installed must be firm and smooth, with no chips, sags, humps, clods, or loose debris that would prevent intimate contact between the water stop and soil. See Chapter 6, paragraph 6-4e, for general guidance on water stops. Because field construction problems are common for the type "A" joints shown in Figure 7-9a with the type U water stop shown in Figure 7-9b, and because the buried base slab does not experience wide temperature changes, an optional base slab joint is allowed when the base is placed. This base slab joint uses construction joints without water stops but with the base slab longitudinal reinforcement continuous through the joint. When this option is used, longitudinal reinforcement of at least 0.4 percent of the slab cross-sectional area must be provided in the base slab, half in each face, but with not more than #9 reinforcing bars at 12-inch spacings in each face.

7-14. Contraction and Expansion Joints. Contraction and expansion joint details are illustrated in Figures 7-9a through 7-9c. Contraction joints (type A) should contain a bond-breaker. Expansion joints (type "B") should contain 1/2-inch preformed expansion joint filler in:

a. All protruding (convex on water side) monolith bases, and in selected reentrant monolith bases and stems as shown in Figure 7-6.

b. In bases and stems of alternate monolith joints in straight-line runs, if warranted by previous experience with similar foundation conditions.

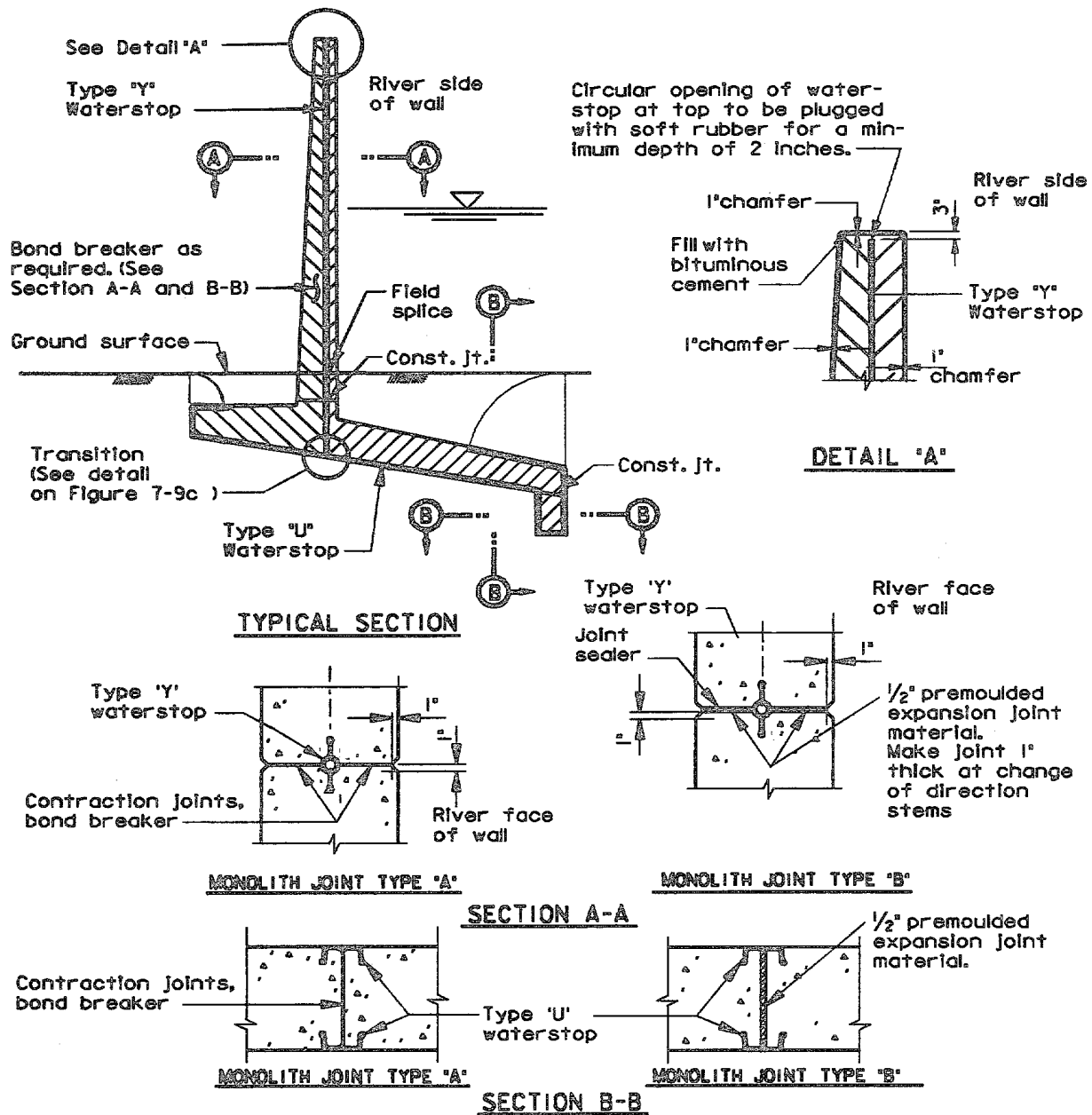

MONOLITH JOINT DETAIL

NOTES:

1. Extreme care should be exercised in placing type 'U' rubber waterstop to insure firm contact with the prepared subgrade throughout its entire contact area.
2. Type 'A' joint used in straight runs of wall, 30 feet spacing
3. Type 'B' joint used in junctures of wall with gate wells, pump stations and gate abutments, and in change of direction monoliths.

a. Monolith joint detail

Figure 7-9. Typical joint and water stop details (Sheet 1 of 3)

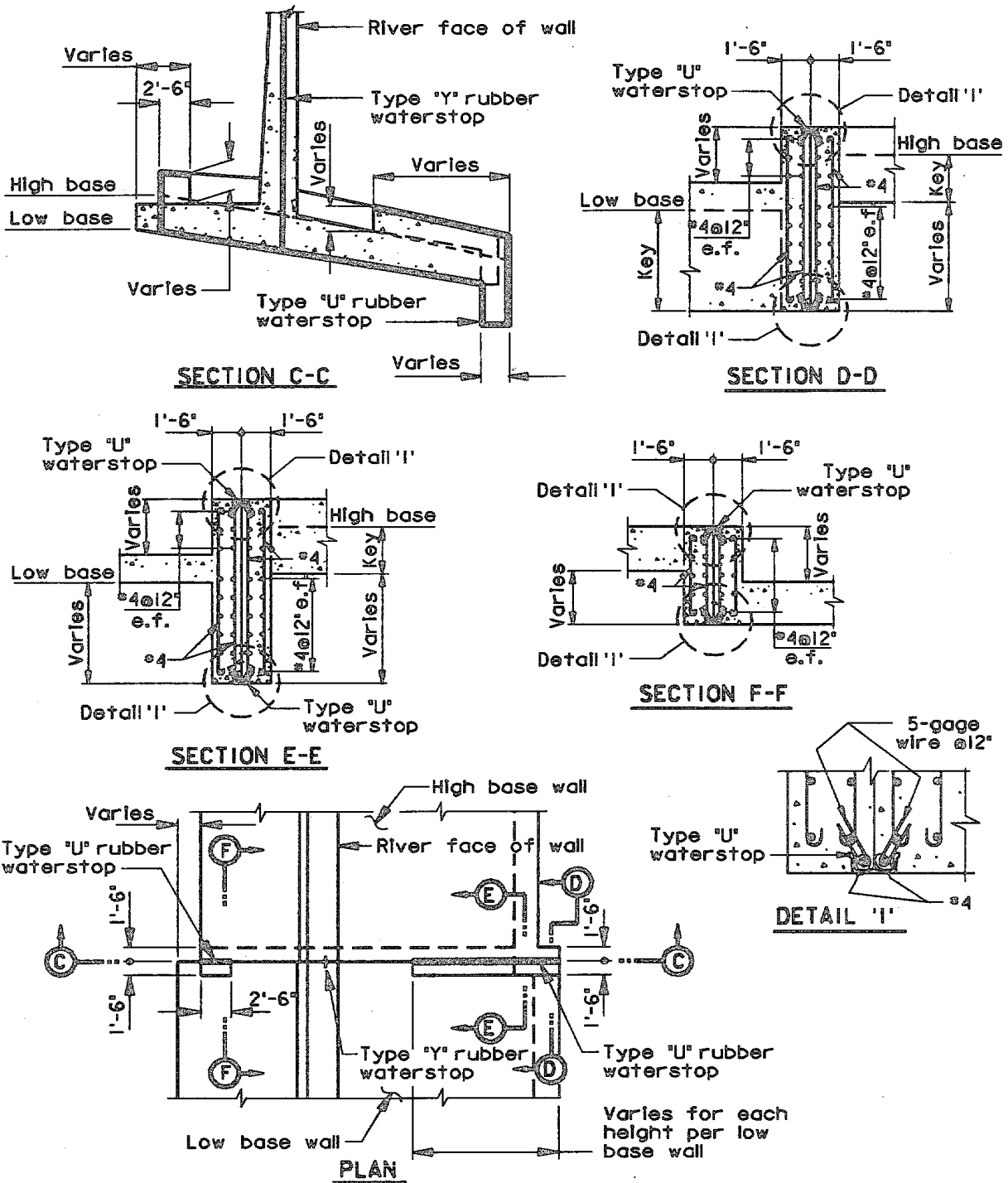

TRANSITIONS AT CHANGES IN WALL HEIGHT

b. Transitions at changes in wall height

Figure 7-9. (Sheet 2 of 3)

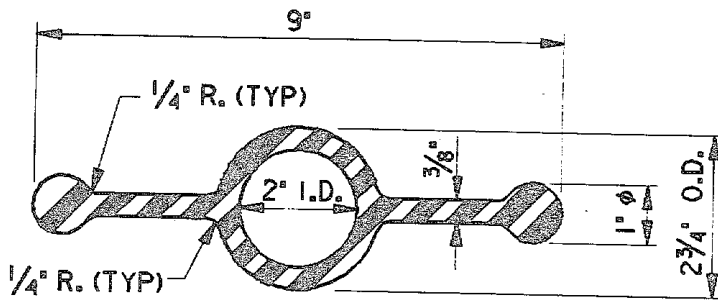

TYPE 'Y'

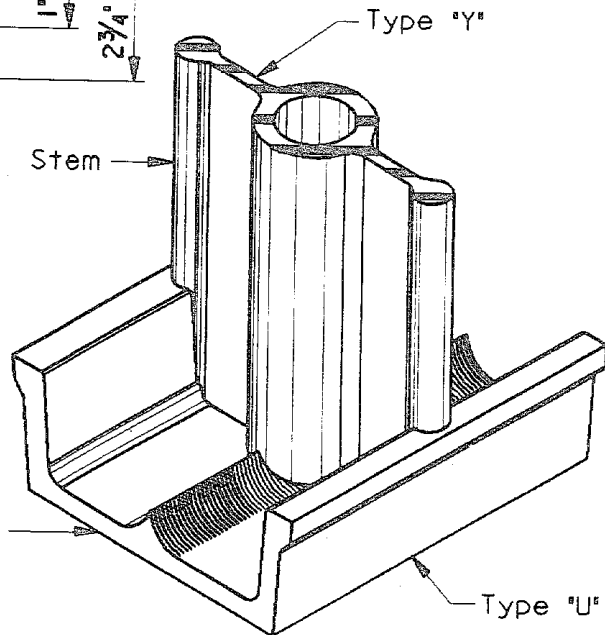

The Type 'Y' and Type 'U' waterstops shall be joined by vulcanizing if rubber waterstops are used ; or by heat sealing the joint if PVC waterstops are used.

TRANSITION BETWEEN STEM AND BASE
ISOMETRIC SKETCH

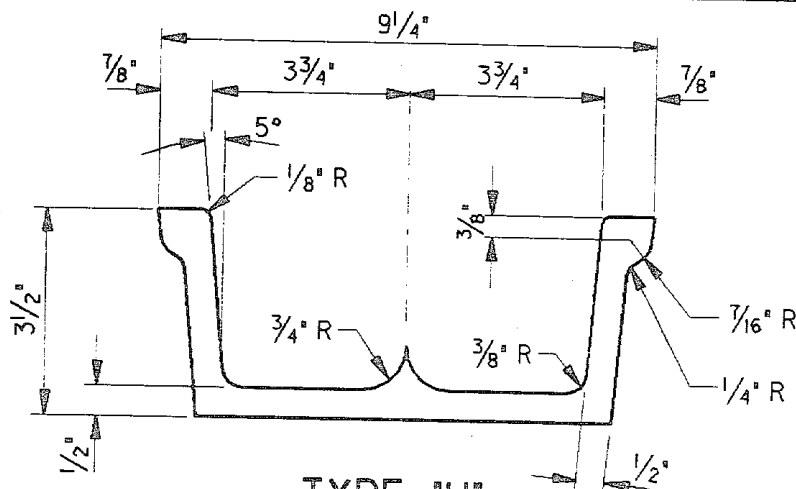

TYPE 'U'

c. Water stop details

Figure 7-9. (Sheet 3 of 3)

c. In bases and stems of junctures of walls with gate wells, pump stations, gate abutments, and similar structures. Nonflexible material in a protruding angle joint is particularly dangerous.

d. See paragraph 6-4 for general guidance on joints.

Section VI. Site Considerations

7-15. Adjacent Structures and Rights-of-Way. Flood walls are usually built because only a narrow right-of-way is available. The presence of existing buildings or other structures is usually the reason for a narrow right-of-way. Sewer pipes with open joints, structures with basements, and excavations close to the wall may create a hazard to the safety of a flood wall. Also, new structures that are built close to existing flood walls can create the same hazards. Present right-of-way acquisition policies do not permit legal restrictions to be placed on future construction; however, local interests should be advised in writing of potential hazards, of required design and construction measures, and should be requested to closely supervise new construction close to the flood wall. Potential hazards can be avoided by proper design and construction measures. One hazard that should be considered is seepage. A basement or other excavation on the landside of the flood wall may result in shortened seepage paths. A basement or excavation on the riverside may also create a safety hazard if it penetrates the impervious blanket or shortens the seepage path. When feasible, the basement or excavation should be backfilled with the same type of material existing in the foundation of the flood wall. If relief wells are selected to control seepage they should be located, if at all possible, between the flood wall toe and the adjacent structure. Protection of the basement area may require lowering of discharge elevations for safeguarding the wall. The location of relief wells within a basement area is not prohibited, but it leads to problems of construction, maintenance, and discharge collection. If the seepage problem is only one of quantity, sump pumping may be used during periods of high water. A second hazard that landside basements and excavations create is to lessen the resistance to sliding along a foundation failure plane. For this reason potential planes of sliding into basements or excavations should be studied. If backfilling is not possible, other measures include the addition of fill between the stem and the building or strengthening the basement to provide the needed resistance. Riverside excavations which contribute to riverward foundation instability should be backfilled, at least to the extent that stability requirements will be satisfied. For the special situation where a wall in a congested location is subjected to an unusually large horizontal force, such as the force of a breaking wave, T-type flood walls are frequently worth the extra cost over other types of construction. This situation requires an unusually wide base for sliding stability, requiring more right-of-way and, hence, more cost for construction. The relatively thin stem of the T-wall does, however, provide the most usable surface area adjacent to the stem after backfilling, in comparison with embankment, braced walls, etc., making the T-wall the preferred solution in spite of the extra construction easement right-of-way. While an I-wall also provides little intrusion on the completed

surface area, its use can be precluded by the pile-driving vibration and consequent chance of damage to adjacent structures.

7-16. Architectural and Landscaping Considerations. Aesthetics should be considered in the design of flood walls, from the standpoint of blending the project with the surroundings. Whenever possible, the wall should appear to be a natural extension of the local topography. The basic design of these structures should be a coordinated effort between the design engineer, the architect, and the landscape architect. While it is seldom feasible to preserve the natural setting intact, design techniques and careful construction methods can be used to protect or even enhance the aesthetic value of the immediate project area. Landscape planting design for project structures should consider the entire area affected by the contemplated construction. Further details may be found in EM 1110-1-2009 and EM 1110-2-301.

Section VII. Instrumentation

7-17. General and Specific Considerations. Flood wall instrumentation should be considered so that performance can be monitored, particularly during periods of high water. The decision on how much, if any, instrumentation is appropriate must be based on these factors:

- a. Who will monitor and evaluate the instruments--Corps of Engineers, local interests, etc., and how meaningful their evaluations are expected to be.
- b. Access to the instruments during flood conditions, especially during hurricane-flood situations where high winds may make accessibility impossible.
- c. Time required for meaningful evaluation, compared with the expected duration of the flooding.
- d. Other particular considerations for specific situations.

The instrumentation descriptions that follow must be implemented in light of the above decision. Specifically, areas with high walls, low embedment ratios, replaced foundation materials, overbank fills, pervious materials in the foundation, and changes in direction should be considered for instrumentation. When founding a flood wall on earth, the distance between monoliths with piezometers should not exceed 1,000 feet unless warranted by site conditions. Properly installed, maintained, and observed instrumentation can forewarn of dangerous conditions that may affect the stability of the structure. All instruments should be read soon after construction is complete. Knowing the as-built conditions of the wall is essential for an accurate determination of later behavior. Initial piezometer readings should be repeated until equalization (steady state) occurs. All instrumentation readings should be made by trained survey or flood-patrol personnel. Ideally, all instruments will be read frequently during high water stages. During design floods, the procedure may prove almost impossible because of the need for trained personnel to direct flood fights; but readings should be made at

certain, previously selected, critical locations during design flood stages. During normal water stages, instruments should be read prior to district periodic inspections so that the inspection party has the necessary evaluation data. Such data also provide a history of flood wall reactions over the years, during both high and normal water. Information concerning frequency and manner of conducting periodic inspections and evaluations is contained in ER 1110-2-100, while ER 1130-2-339 covers local flood protection projects.

7-18. Types of Instrumentation. The principal types of flood wall instrumentation monitor movements, both vertical and horizontal, and hydrostatic pressures in the foundation. The instruments selected should be simple to install and observe, and efficient in performance and functional reliability. The monitoring of the movements provides an indication of possible sliding instability or possible water stop rupture. The piezometers provide a record of hydrostatic pressures in the foundation which can indicate uplift and possible excessive seepage pressures. Instrumentation systems, installations, and devices are discussed in detail in EM 1110-2-4300.

a. Movement Monitoring. All reference points to monitor movements should be tied in to a permanent baseline located so that it is unaffected by movements of the wall. When establishment of a baseline is not feasible, the relative movements observed between monoliths or by means of triangulation can provide valuable data on behavior of the wall. Reference points to monitor the wall movements need to be installed during construction. Noncorrosive metal plugs should be installed in the top surfaces of the stems within 6 inches of each end of each monolith. The reference marks in the plugs of four to six successive monoliths should be placed in a straight line with theodolite or stretched wire. At changes in alignment, the straight line should be continued until it intersects the far side of the next monolith and a reference point for alignment control is placed. Each plug's changes in horizontal movement and elevation should be measured to 0.001 foot. Stations to be read with electronic optical reading devices need to be established at locations near the ground surface level on the landside of the stem. Selection of electronic-optical station locations for the stem should be based on factors such as changes of direction, areas of overbank fill, foundation replacement, high walls, low embedment ratios, and junctures of flood walls with drainage structures. The monitoring system selected should be vandalproof. In many cases the monitoring system can be tied into the same baselines established for the reference markers on top of the wall. Tilting of stems can be measured by a tiltmeter.

b. Foundation Piezometers. Design, installation, and observations of piezometers are described in EM 1110-2-1908, Part I. The simplest, most reliable method of measuring pore water pressures is the open tube piezometer. For impervious soils, the Casagrande type of piezometer with 24-inch-long porous stone is recommended. In order to measure the piezometric pressure at the porous tip, the boring for installation of the Casagrande piezometer must be effectively sealed against migration of seepage along the piezometer riser. For semipervious to pervious soils, a driven wellpoint type of piezometer is recommended. Where possible, the wellpoint should be driven into undersized,

pre-bored holes. More piezometers can be added if foundation conditions warrant.

Section VIII. Operation and Maintenance Manual Requirements

7-19. General Coverage. General coverage of the requirements of local cooperation is contained in EM 1120-2-109. As written, the regulations are general in nature and obviously cannot give detailed instructions for the maintenance and operation of a specific project. Therefore, it is necessary for the district office having jurisdiction over the specific project to issue an adequate operation and maintenance manual for the guidance of local interests.

Section IX. Review of Existing Flood Walls

7-20. Inspection. Flood walls should be examined during scheduled periodic inspections, after major periods of high water, and when special events warrant an inspection (building or excavating near the wall, etc.). A determination of areas which may be weak or critical from the standpoint of leakage and stability should be made. Criteria for this determination are described below. Areas deficient in any of the criteria will be considered weak or critical, depending on the degree of deficiency.

a. Horizontal Movement. Areas in which movement of a straight section of monoliths or differential movement between any two monoliths is greater than expected will be considered critical.

b. Joint Opening or Spreading. Joints referred to in this paragraph are those having a water stop embedded in the interior of the section. Using the results of the full-size flood wall test performed by the Ohio River Division, (ORD) in 1955, expected spreading of joints at 90-degree reentrant corner monoliths (concave on the riverside) will be 42 percent of the expected movement of the straight run walls. Not only may joints at corner monoliths become critical upon application of load, but open joints below ground should be considered critical. Any joint can become open through loss of joint filler or through unequal settlement between adjacent monoliths or structures such as levees, pump houses, gate wells, and gate abutments. Some joints below ground may need to be excavated to determine the adequacy of joint filler. If the expected joint opening is greater than the allowable, the area should be considered critical.

c. Foreign Material in Joints. The presence of inflexible foreign material, such as grout and pieces of aggregate, in expansion joints is dangerous from two standpoints. Grout, particularly if located within the fold of the water stop, destroys the flexibility of the water stop and, upon the occurrence of differential movements, allows the water stop to be torn. Grout and pieces of aggregate anywhere in the joint prevent the joint from fulfilling its expansion function. This condition becomes particularly dangerous at protruding angle locations; i.e., where the wall appears convex when viewed from the river. Here, the wall may be tilted waterward by a wedging action upon expansion of adjacent monoliths in hot weather. This wedging of adjacent

monoliths at changes in alignment is likely to force excessive flexure in the stem, sufficient to cause failure. The same tilting can occur at reentrant monoliths (Figure 7-6), but there the tilting is landward and the reinforcing is more adequate to resist the stress. For angle monoliths protruding toward the river, the landside temperature steel can be quickly overstressed.

d. Water Stops. Joints with torn or parted water stops should be considered critical. Torn water stops may not be noticed during an inspection, particularly if the joint has not spread open. If sufficient differential movement has occurred, it should be assumed that the water stop is torn. The amount of tearing to be allowed should be based on factors causing piping; however, this is very difficult to predict. In the above cases, if a total differential movement (transverse and longitudinal combined) of 1/2 inch or more has occurred, the water stop should be considered torn unless shown otherwise.

e. Foundation Voids. All unequal settlements should be viewed with suspicion. In particular, unequal settlements adjacent to structures such as pump houses and gate wells should be the subject of rigid examination. Usually one or two monoliths (or a portion of one monolith) are constructed on compacted fill in these areas. Initial unequal settlement may cause the first monolith to bridge or wedge between the second monolith and the other structure. Further consolidation of the fill then leaves a dangerous void or voids under this base. Only underground examination will reveal the presence of these voids.

f. Stability Analyses. Original seepage assumptions or patterns should be reviewed for realistic representation of actual foundation conditions. Particular attention should be paid to foundations having pervious strata which connect directly with the river. Where indicated, seepage and/or stability analyses should be recomputed as described in Chapters 3, 4, and 5. In addition to a recomputation of uplift, the shear strengths used in the original analyses should be reevaluated on the basis of a study of types of soil and their drainage and consolidation characteristics. In cases where there is a lack of sufficient foundation information in areas suspected to be weak, new soil samples should be obtained as close to the existing wall as is feasible. Areas found to have questionable stability should be closely observed during high floods.

g. Basements and Other Excavations. The seepage aspects and the foundation stability of walls which have had basements excavated on either side of and adjacent to the wall since the original design and construction were completed should be investigated.

h. Seepage Conditions Landside of Flood Walls. These areas should be investigated thoroughly and seepage control of pressure relief provided, if needed.

29 Sep 89

7-21. Repair Measures.

a. General. The following repair measures are only suggestions. Their use is not mandatory if more feasible or economical measures can be devised for the individual problems involved.

b. Additional Landside Cover. The most obvious and straightforward method for reducing anticipated horizontal movement or increasing sliding stability is the addition of landside cover or fill to the wall (see Figure 7-10). At locations where additional landside fill is not feasible or possible due to highways, railroads, and other structures, measures to reduce seepage pressure (such as those described below in paragraph 7-21d) will have to be employed to decrease landward movement or increase sliding stability.

c. Additional Waterside Cover. In areas where earth cover over the waterward end of the heel is deficient, the recommended remedy is the addition of cover.

d. Supplemental Water Stops. The supplemental water stop scheme shown in Figure 7-11, a and b is a means of correcting for torn water stops, open joints, and possible earth cracking over the key because of thin heel cover or excessive movements. The sheet piling shown in the scheme is necessary to provide additional cutoff to compensate for loss of part or all of the normal seep path between earth and the waterside face of the key. The pile cap should be placed at the bottom of the key to limit excessive leakage of water around the upstream and downstream ends of the pile curtain as the wall moves landward under load. Another possible method of repair is to seal the opening below the existing water stop in the base by injecting cement grout. The opening above the water stop in the base could be sealed with an elastic sealant such as polysulphide elastomer.

e. Other Problem Areas. Foreign incompressible material in the joints should be removed by the most expedient method. Riverside excavations near the heel should be backfilled with impervious material if it is suspected that dangerous seepage conditions may occur during high water.

f. Overtopping Scour Control. For coastal walls or other walls where scour has removed landside cover, consideration should be given to placing concrete slabs over the restored cover within a distance of 20 feet from the wall stem.

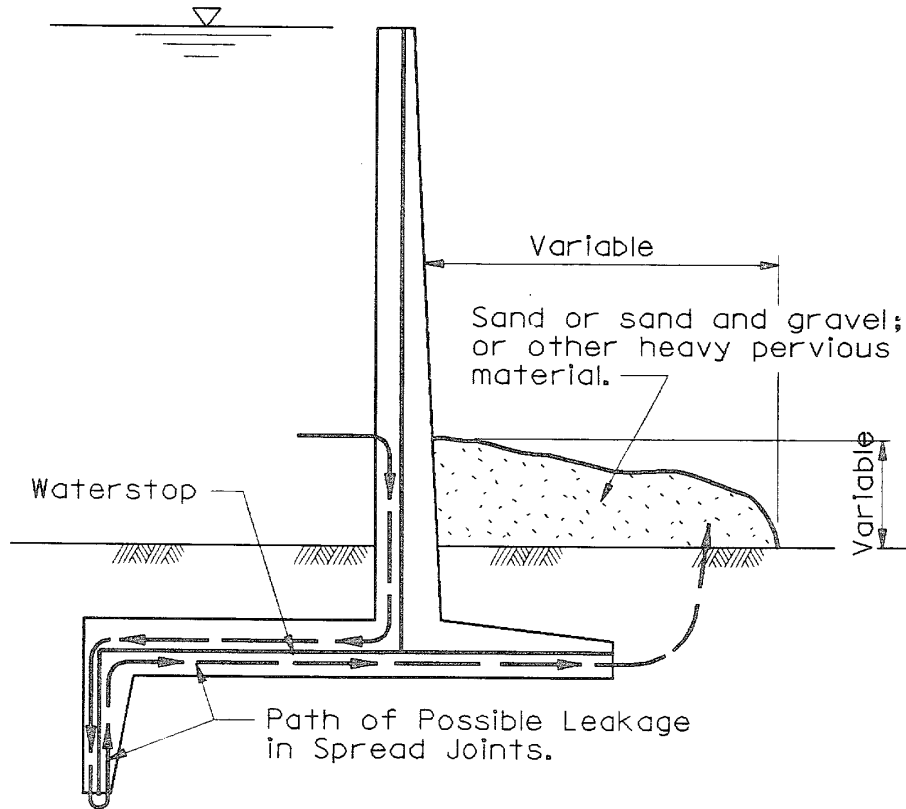

Note: The area and depth of material shall be sufficient to prevent loss of foundation material as determined by observation of the outflow.

Figure 7-10. Emergency measures to control piping

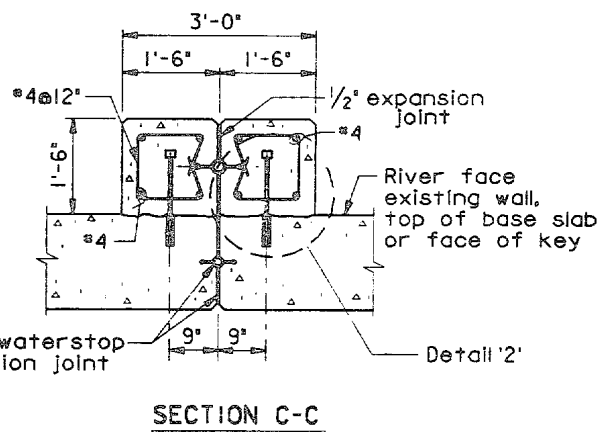
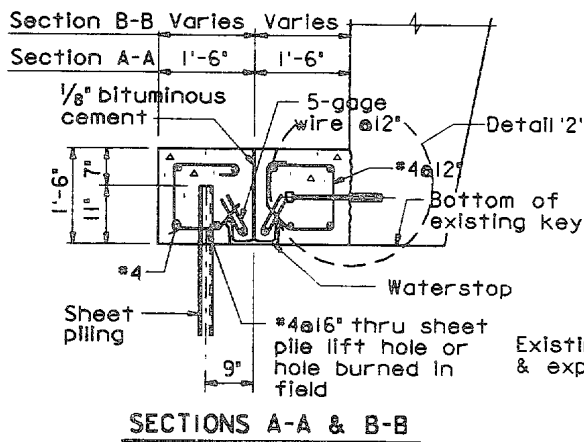
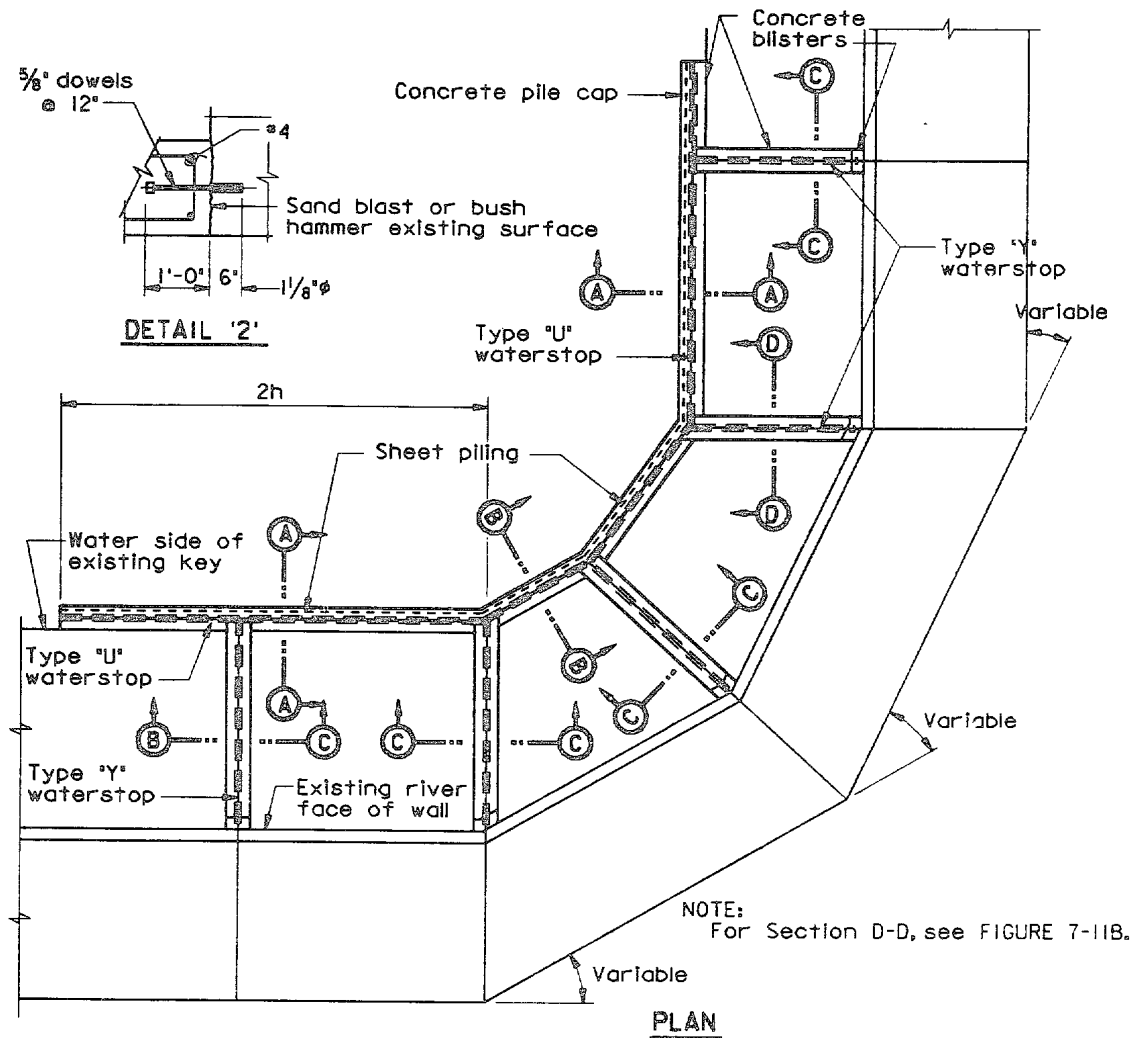

a.

Figure 7-11. Permanent water stop repair measures (Continued)

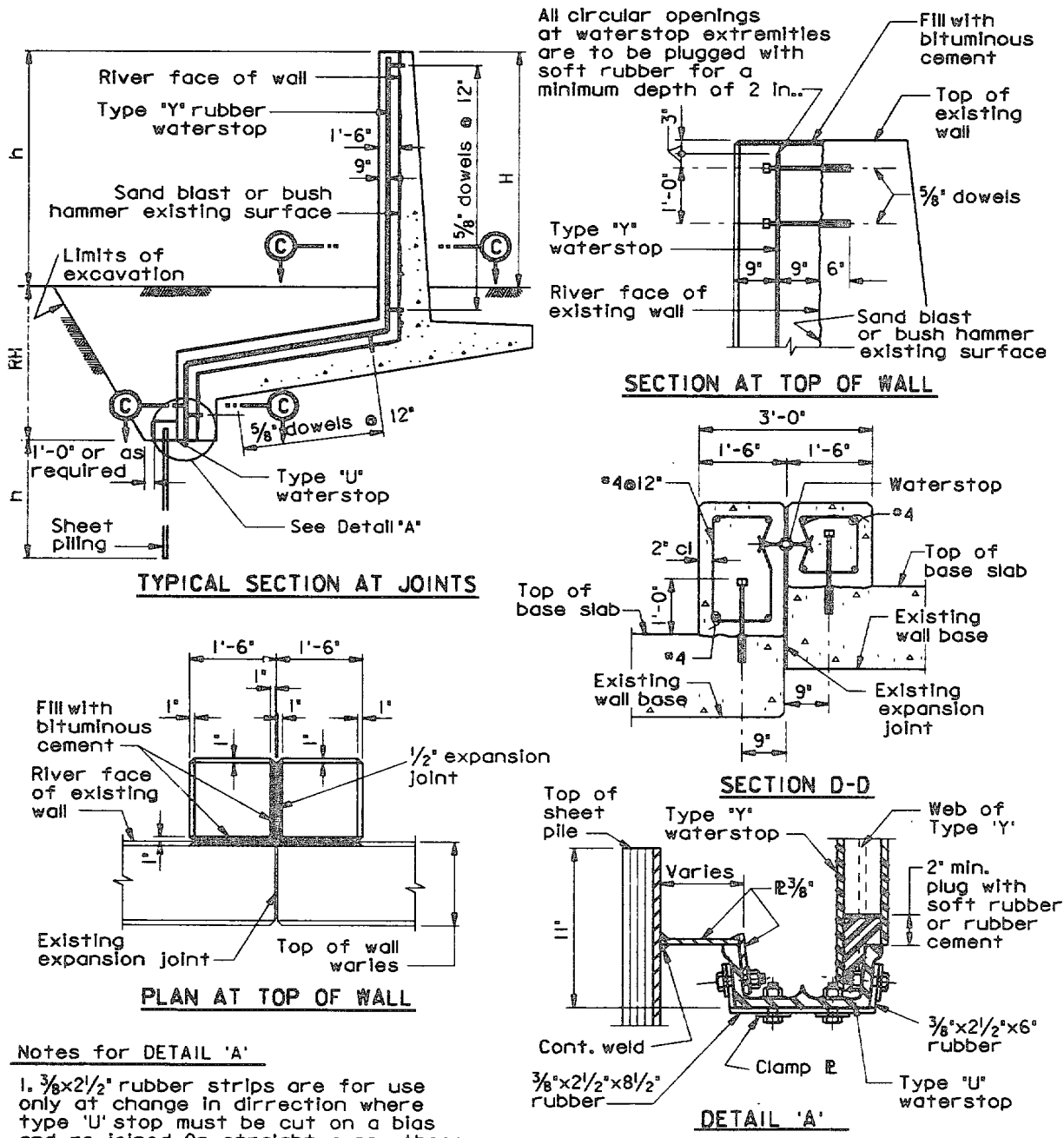

TYPICAL SECTION AT JOINTS

SECTION AT TOP OF WALL

SECTION D-D

PLAN AT TOP OF WALL

DETAIL 'A'

Notes for DETAIL 'A'

1. $\frac{3}{8} \times 2\frac{1}{2}$ inch rubber strips are for use only at change in direction where type 'U' stop must be cut on a bias and re-joined. On straight runs these strips need not be used.
2. Bulbs of type 'Y' stop are shaved down to web to provide a flat surface for bolting to inside of type 'U' stop.
3. All rubber surfaces in contact with each other are coated with rubber cement.

NOTES:

1. For details of 'Y' & 'U' type rubber waterstop, see FIGURE 7-9C
2. All steel in blisters 2" clear.
3. For Section C-C, see FIGURE 7-11A
4. For Section D-D location, see FIGURE 7-11A

b.

Figure 7-11. (Concluded)

CHAPTER 8

CONCRETE GRAVITY WALLS

8-1. General Factors. Factors favoring concrete gravity retaining walls are shallow depth of overburden, a competent foundation, and an adequate source of fine and coarse aggregate for the required volume of concrete. See Chapter 2, Section I for additional comments on gravity walls.

8-2. Foundation Investigation. The requirements for the foundation investigation are discussed in Chapter 2, Section V.

8-3. Materials. A concrete compressive strength of 2,000 to 2,500 psi will usually meet the requirements for the gravity type wall. Where the environment requires durability, such as at the outer surface of the wall, the higher strength should be achieved with the appropriate water-cement ratio from EM 1110-2-2000.

8-4. Design.

a. Magnitude and Distribution of Forces.

(1) Dead Load. The unit weight of concrete is usually assumed to be 150 lb/cu ft. This value may vary, depending on the aggregate. Other dead loads that should be considered are superimposed backfill and the weights of any equipment or other structures supported by the wall.

(2) External Water Pressure. The pressure exerted by water above ground and water in the ground should be determined as described in Section III of Chapter 3.

(3) Internal Water Pressure (uplift). The uplift on a lift (horizontal construction joint) within the body of a concrete gravity wall for long-term water levels should be taken as 50 percent of the value obtained by assuming a straight line variation between the full hydrostatic pressures acting on each side of the wall. Uplift pressures on the base of the wall should be determined by the methods described in Section III of Chapter 3.

(4) Lateral Earth Pressures. Lateral earth pressures should be determined by the methods presented in Section II of Chapter 3. Computation examples, as applied to gravity walls, are shown in examples 5, 6, 8, 10, and 11 of Appendix M.

(5) Wind and Earthquake Forces. These supplemental forces should be determined by the methods presented in Section IV of Chapter 3.

b. Load Cases. The load cases should be those described in Section I of Chapter 4.

29 Sep 89

c. External Stability. Sliding and overturning stability should be determined by the methods and criteria discussed in Chapter 4. Computer program 3DSAD will significantly assist in performing stability analyses. An example of a complete stability analysis of a gravity wall section is shown in example 2 of Appendix N.

d. Internal Stability. The resultant of all forces acting on any horizontal section should fall within the kern or sufficiently close to the kern of the section to keep the tensile stresses low. See EM 1110-1-2101 for allowable concrete stresses.

e. Foundation Analyses. Foundation analyses should be performed in accordance with the methods described in Chapters 4 and 5.

CHAPTER 9

CANTILEVER REINFORCED CONCRETE WALLS

9-1. General Characteristics. The cantilever reinforced concrete wall is a special type of gravity wall in which part of the stabilizing weight is supplied by the weight of the backfill resting on the base slab. The structural members are designed for stresses due to bending and shear. Chapter 2, Section I, offers additional general comments on cantilever concrete walls.

9-2. Foundation Investigation. The requirements for the foundation investigation are discussed in Chapter 2, Section V.

9-3. Materials. Concrete materials and mixture proportioning, with appropriate water-cement ratios for durability, should follow guide specification CW 03301 and EM 1110-2-2000. Typically, a concrete compressive strength of 3,000 psi is used for retaining walls. The age at which the specified strength is to be obtained should be decided by the designer depending on the loading conditions anticipated. Steel reinforcement bars should follow the specifications in the American Concrete Institute (ACI) Building Code (ACI 318), with the exception that for hydraulic structures the grade of steel will be limited to ASTM Grade 60 without special approval.

9-4. Reinforcement Cover. For hydraulic structures the minimum reinforcement cover should comply with EM 1110-2-2103. For structures not subject to hydraulic action the minimum reinforcement cover should comply with the ACI Building Code requirements.

9-5. Load Cases. The load cases should be those described in Section I of Chapter 4. The magnitude and distribution of the loads should be determined as described in Chapter 3.

9-6. Structural Stability. Sliding and overturning stability should be determined by the methods and criteria discussed in Chapter 4. Forces and moments for structural design should be based on external forces allocated according to paragraphs 3-7 through 3-9 and calculated as described in Section III of Chapter 4 for overturning stability. Sample stability calculations are shown in Appendix N.

9-7. Structural Design.

a. General. Reinforced concrete walls should be designed for the loading cases given in Section I of Chapter 4 and the foundation pressures obtained from the overturning stability analysis described in Section III of Chapter 4. Wall components should be analyzed as cantilever beams. Compression reinforcement is not normally used. Temperature and shrinkage reinforcement should conform with EM 1110-2-2103. Example calculations are shown in Appendix N. When the top surface of backfill is sloping upward, a shear force in addition to the horizontal earth force should be considered acting on the structural wedge (see Figure 9-1).

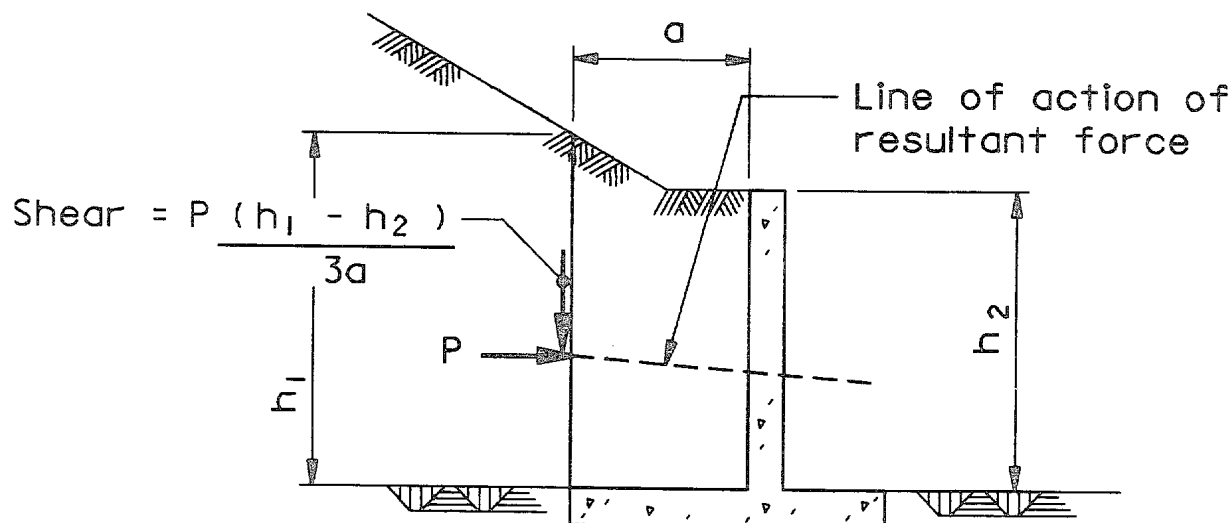

Shear Force when $h_1 > h_2$

Figure 9-1. Shear force for upward-sloping backfill

- b. Stem. Axial loads are usually small and may be neglected in design.
- c. Toe. The toe should be designed with loads imposed by soil, water, concrete, bearing pressures, etc. The effects of axial loads are not ordinarily substantial enough to be taken into account.
- d. Heel. The loads for calculating design moments are the weight of soil, water, and concrete acting downward, along with uplift and bearing pressure acting upward. The bearing pressure should be determined using the horizontal earth force and shear when the backfill surface is sloping upward (see paragraphs 9-7a and 4-8c). With no key, the base shear should be neglected when computing reinforcement, as illustrated in Appendix N, example 1.
- e. Special Considerations for Walls with Keys. The overturning stability criteria for walls with keys include an assumed uniform distribution of earth pressure on the resisting side of the key that may result in unconservative design for reinforcement in the top face of the wall heel at and near the face of the stem. A portion of this force may actually act along the plane at the base slab of the wall and not on the key. The designer is cautioned to consider this in developing a reinforcing design. A conservative approach for design of the heel top steel at the stem would result from the use of foundation pressures obtained from a stability analysis assuming that all of the earth resistance acts along the plane at the base of the wall. See Section III of Chapter 4, especially paragraph 4-8b. Stability calculations for walls with keys are shown in examples 3 and 6 of Appendix N.

9-8. Reinforced Concrete Design.

a. General. Reinforced concrete walls should be designed with the strength design method in accordance with the current ACI Building Code, except as herein specified. Notations used are the same as those in the ACI Code, except those defined herein. (Appendix D lists the Notation used in Chapter 9.) WES Technical Report SL-80-4 (Liu and Gleason 1981) contains design aids consistent with the information presented in paragraph 9-8b of this chapter. Retaining walls and flood walls may be designed using the same load factor for concrete weight as that selected for earth and water loads, as explained in paragraph 9-8b(1), Equations 9-5 and 9-6.

b. Hydraulic Structures--Strength and Serviceability.

(1) Required Strength. Reinforced concrete hydraulic structures should be designed to have strengths in all sections equal at least to those calculated for the factored loads and forces in the following combinations that are applicable.

(a) For usual loading cases R1, I1, C1, C2a, and C2c as described in Chapter 4:

$$U = 1.5D + 1.9L \quad (\text{if } D \text{ and } L \text{ have the same sign}) \quad [9-1]$$

or

$$U = 0.9D + 1.9L \quad (\text{if } D \text{ opposes } L) \quad [9-2]$$

where

D = internal forces and moments from dead load of the concrete members only

L = internal forces and moments from live loads (loads other than the dead load of concrete members)

(b) For unusual or extreme loading conditions such as cases R2, R3, I2, I3, I4, C2b, C3, C4, and C5, earthquakes, and short-term loadings:

$$U = 0.75(1.5D + 1.9L) \quad (\text{if } D \text{ and } L \text{ have the same sign}) \quad [9-3]$$

or

$$U = 0.75(0.9D + 1.9L) \quad (\text{if } D \text{ opposes } L) \quad [9-4]$$

(c) In most retaining walls and flood walls, dead loads represent a small percentage of total loads and the additional effort to recompute another stability analysis using the above two factors may not be warranted. Therefore, a single load factor as defined by Equation 9-5 may be substituted for Equations 9-1 and 9-2 to avoid having to recompute an alternate stability analysis with a different set of loadings. Likewise, Equation 9-6 may be substituted for Equations 9-3 and 9-4.

$$U = 1.9(D + L) \quad [9-5]$$

$$U = 0.75[1.9(D + L)] \quad [9-6]$$

Note that the ACI definition of D is modified so that

D = dead load of the concrete members only or related axial forces, shears, and moments

L = all loads other than dead load of concrete, or related axial forces, shears, and moments

(d) When multiple load factors are used and the reactions (i.e., base reactions, pile reactions, resisting earth pressures, etc.) are computed using the applied factored loads, the following combinations should be considered:

$$\text{From Equation 9-1: } U = 1.5D + 1.9L + R_f \quad [9-7]$$

$$\text{From Equation 9-2: } U = 0.9D + 1.9L + R_f \quad [9-8]$$

$$\text{From Equation 9-3: } U = 0.75(1.5D + 1.9L + R_f) \quad [9-9]$$

$$\text{From Equation 9-4: } U = 0.75(0.9D + 1.9L + R_f) \quad [9-10]$$

where R_f equals internal forces and moments resulting from reactions induced by the applied factored dead and live loads.

(e) When the single load factor is used and the reactions (i.e., base reactions, pile reactions, resisting earth pressures, etc.) are computed using the applied unfactored loads, the following combinations should be considered: (See paragraphs j and k, Example 1, Appendix N).

$$\text{From Equation 9-5: } U = 1.9(D + L + R) \quad [9-11]$$

$$\text{From Equation 9-6: } U = 0.75 [1.9 (D + L + R)] \quad [9-12]$$

where R equals internal forces and moments resulting from reactions induced by applied unfactored dead and live loads.

(2) Design Strength of Reinforcement. The design should be based on yield strengths of reinforcement of 40,000 psi and 48,000 psi for ASTM Grades 40 and 60 steels, respectively, except for calculating development lengths. The development length for Grades 40 and 60 steels should be based on yield strengths of 40,000 psi and 60,000 psi, respectively. Reinforcement with a yield strength in excess of Grade 60 should not be used unless a detailed investigation of ductility and serviceability requirements is conducted in consultation with and approved by Headquarters, US Army Corps of Engineers (HQUSACE) (CECW-ED).

(3) Maximum Tension Reinforcement. For flexural members and for members subject to combined flexure and compressive axial load when the design load strength ϕP_n is less than the smaller of $0.10f'_c A_g$ or ϕP_b , the ratio of tension reinforcement provided generally should not exceed $0.25 \rho_b$. Reinforcement ratios greater than $0.25 \rho_b$ but less than $0.50 \rho_b$ may be used in retaining walls if excessive deflections are not predicted when using the method specified in the ACI Building Code. Reinforcement ratios in excess of $0.50 \rho_b$ should not be used unless a detailed investigation of serviceability requirements, including computation of deflections, is conducted in consultation with and approved by HQUSACE (CECW-ED).

(4) Minimum Reinforcement of Flexural Members. At any section of a flexural member where reinforcement is required by analysis, the minimum reinforcement requirements specified in the ACI Building Code, should apply, except that f_y should be in accordance with paragraph 9-8b(2).

(5) Control of Deflections and Cracking. Cracking and deflections due to service loads need not be investigated if the limits on design strength specified in paragraph 9-8b(2) and a reinforcement ratio of $0.25 \rho_b$ are not exceeded. Where these limitations are exceeded, extensive investigation of deformation and cracking due to service loads should be made in consultation with higher authority.

(6) Distribution of Flexural Reinforcement. The spacing of flexural tension reinforcement should not generally exceed 18 inches for Grade 40 steel, or 12 inches for Grade 60 steel.

(7) Extreme Loadings. For extreme loadings which are highly improbable, such as from earthquakes which have a frequency of occurrence that greatly exceeds the economic life of the structure, selection of less conservative load factors than given in Equations 9-3, 9-4, and 9-6 and less conservative

strength criteria than given above may be justified. For extreme loadings, requests and the justification for varying from the guidance should be submitted to HQUSACE (CECW-E) for approval.

c. Hydraulic Structures--Reinforced Concrete Design.

(1) Design Assumptions.

(a) Strain. The assumed maximum usable strain at the extreme concrete compression fiber should be equal to 0.003. The design strain ϵ_m at the extreme concrete compression fiber should be limited to 0.5 of the maximum usable strain for hydraulic structures.

(b) Balanced Conditions. Balanced conditions exist at a cross section when the tension reinforcement reaches the strain corresponding to its specified yield strength f_y just as the concrete in compression reaches its design strain ϵ_m . T-wall members should be designed for a ductile failure on the tensile side of balance, as described in paragraphs 9-7a, 9-8b(3), and 9-8b(4).

(c) Concrete Stress. A concrete stress of $0.85f'_c$ should be assumed uniformly distributed over an equivalent compression zone bounded by the edges of the section and a straight line lying parallel to the neutral axis at a distance $a = \beta_m c$ from the extreme compression fiber. The factor β_m should be taken as 0.55 for values of f'_c up to 4,000 psi. For values of f'_c greater than 4,000 psi, β_m should be 0.50.

(2) Design Equations. Equations for design and investigation of reinforced concrete sections are given in Figures 9-2 through 9-5. These will be the only equations required to determine flexural adequacy for sections of retaining and flood walls in practically all cases.

(a) The minimum effective depth (d) needed to provide the amount of ductility required by criteria may be determined from the following equation

$$d_{\min} = \sqrt{\frac{M_u / \phi}{0.85f'_c k_m b \left(1 - \frac{k_m}{2}\right)}} \quad [9-13]$$

where

$$k_m = \frac{f_y \rho_{\max}}{0.85f'_c}, \quad \rho_{\max} = \lambda \rho_b$$

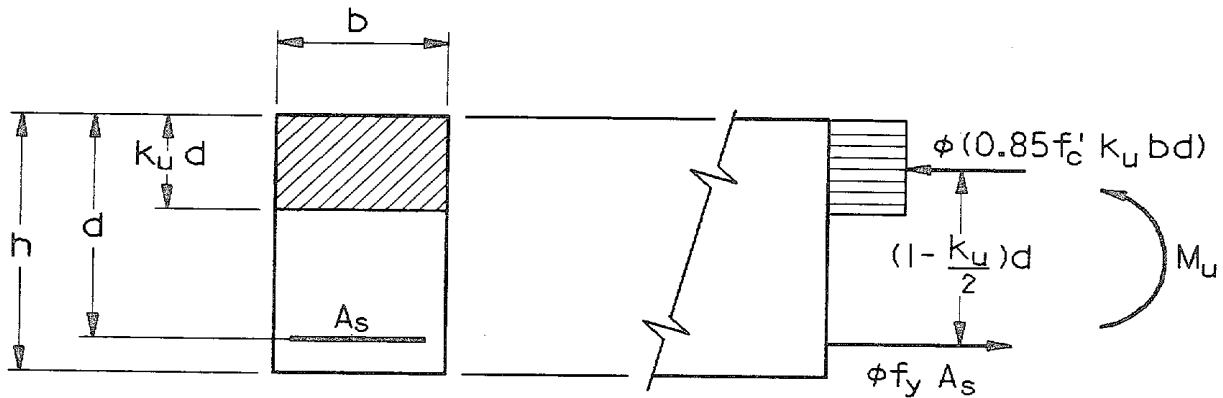

DESIGN

GIVEN : M_u , b , d , h , f_y , f'_c , $\phi = 0.9$

FIND: k_u , A_s AND ρ

$$k_u = 1 - \sqrt{1 - \frac{M_u}{0.425 \phi f'_c b d^2}}, \quad A_s = \frac{0.85 f'_c k_u b d}{f_y}$$

$$\rho = \frac{A_s}{b d} \leq \rho_{MAX}, \quad \rho = \frac{0.85 f'_c k_u}{f_y}$$

INVESTIGATION

GIVEN : b , d , h , f_y , f'_c , $\phi = 0.9$, A_s , $\rho = \frac{A_s}{b d} \leq \rho_{MAX}$

FIND: k_u AND M_u

$$k_u = \frac{f_y \rho}{0.85 f'_c}, \quad M_u = \phi f_y \rho \left(1 - \frac{f_y \rho}{1.7 f'_c}\right) b d^2$$

Figure 9-2. Rectangular beam, simple bending with no compression reinforcement

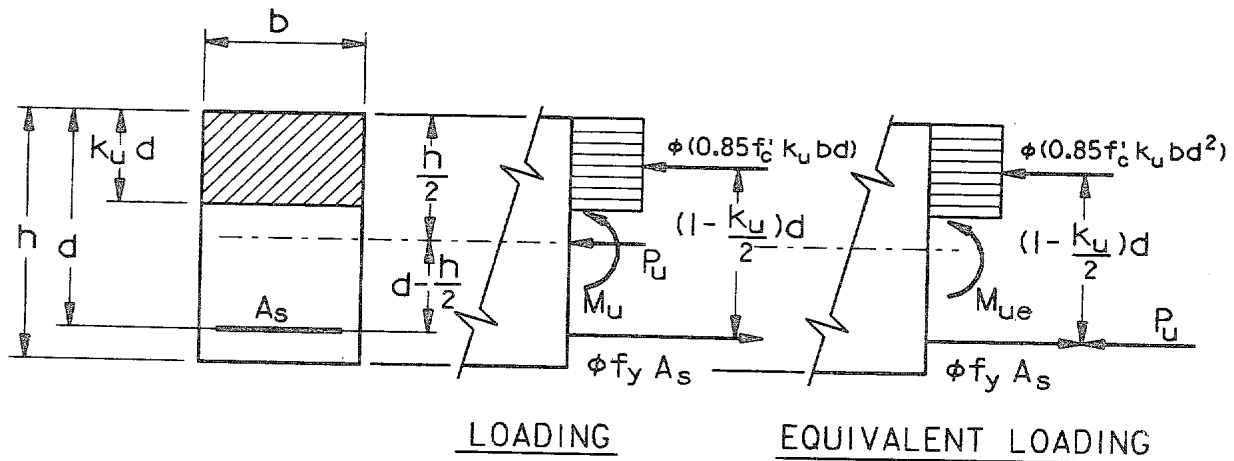

FOR EQUIVALENT LOADING: $M_{Ue} = M_U + P_U (d - \frac{h}{2})$

DESIGN

GIVEN : $P_U, M_U, b, d, h, f_y, f'_c$

(ϕ SHALL NOT BE LESS THAN 0.7) $\phi = 0.9 - (\frac{P_U}{0.1 f'_c b h})(0.2)$

FIND: k_U, A_s AND ρ

$$k_U = 1 - \sqrt{1 - \frac{M_{Ue}}{0.425 \phi f'_c b d^2}} \quad , \quad A_s = \frac{0.85 f'_c k_U b d - \frac{P_U}{\phi}}{f_y}$$

$$\rho = \frac{0.85 f'_c k_U - \frac{P_U}{\phi b d}}{f_y} \leq \rho_{MAX}$$

INVESTIGATION

GIVEN : $P_U, b, d, h, f_y, f'_c, \phi$ (SEE DESIGN), $A_s, \rho \leq \rho_{MAX}$

FIND: k_U, M_{Ue} AND M_U

$$k_U = \frac{\frac{P_U}{\phi b d} + f_y \rho}{0.85 f'_c} \quad , \quad M_{Ue} = [0.85 f'_c k_U (1 - \frac{k_U}{2}) b d^2] \phi$$

$$M_U = M_{Ue} - P_U (d - \frac{h}{2})$$

Figure 9-3. Rectangular member, bending with small axial compression load, no compression reinforcement

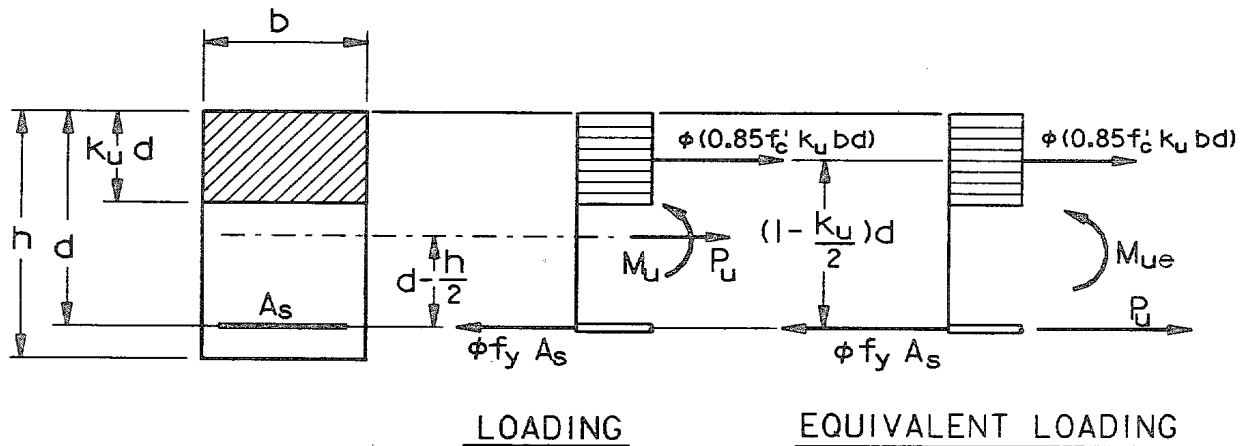

FOR EQUIVALENT LOADING: $M_{Ue} = M_U - P_U (d - \frac{h}{2})$

DESIGN

GIVEN : $P_U, M_U, b, d, h, f_y, f'_c, \phi = 0.9$

FIND: $k_U, A_s, \text{ AND } \rho$

$$k_U = 1 - \sqrt{1 - \frac{M_{Ue}}{0.425 \phi f'_c b d^2}}$$

$$A_s = \frac{0.85 f'_c k_U b d + \frac{P_U}{\phi}}{f_y}$$

$$\rho = \frac{0.85 f'_c k_U + \frac{P_U}{\phi b d}}{f_y} \leq \rho_{MAX}$$

INVESTIGATION

GIVEN : $P_U, b, d, h, f_y, f'_c, \phi, A_s, \rho < \rho_{MAX}$

FIND: $k_U, M_{Ue}, \text{ AND } M_U$

$$k_U = \frac{f_y \rho - \frac{P_U}{\phi b d}}{0.85 f'_c}$$

$$M_{Ue} = [0.85 f'_c k_U (1 - \frac{k_U}{2}) b d^2] \phi$$

$$M_U = M_{Ue} + P_U (d - \frac{h}{2})$$

Figure 9-4. Rectangular member, bending with axial tensile load, where $M_U/P_U \geq (d - h/2)$

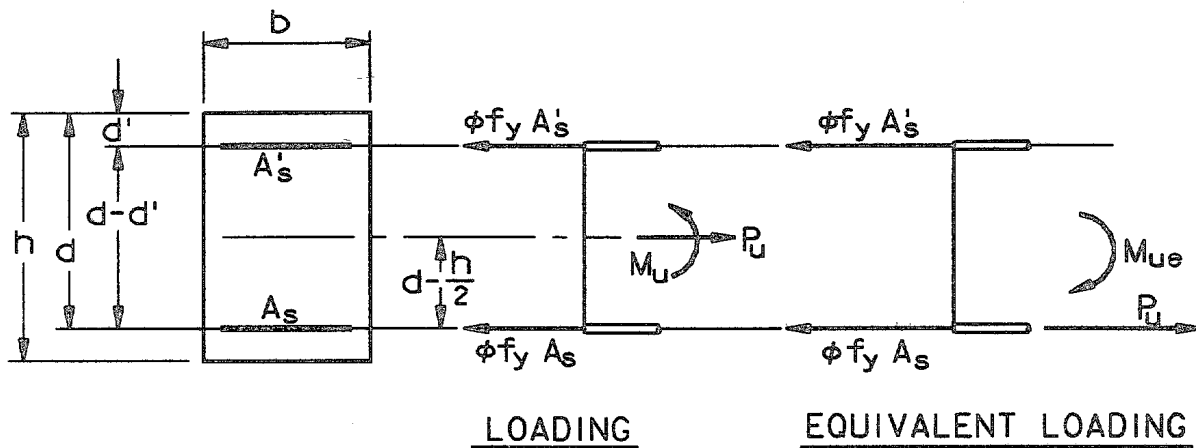

FOR EQUIVALENT LOADING: $M_{ue} = -M_u + P_u \left(d - \frac{h}{2}\right)$

DESIGN

GIVEN : $P_u, M_u, b, d, h, f_y, f'_c, \phi = 0.9$

FIND: A_s AND A'_s

$$A_s = \frac{\frac{P_u}{\phi} - f_y A'_s}{f_y}, \quad A'_s = \frac{M_{ue}}{\phi f_y (d - d')}$$

INVESTIGATION

GIVEN : $P_u, b, d, h, f_y, f'_c, \phi = 0.9, A_s$ AND A'_s

FIND: M_{ue}, M_u AND f'_s (STRESS IN A'_s)

$$M_{ue} = (P_u - \phi f_y A_s)(d - d')$$

$$M_u = P_u \left(d - \frac{h}{2}\right) - M_{ue}$$

$$f'_s = \frac{\frac{P_u}{\phi} - f_y A_s}{A'_s} \quad \left(\text{NOT NECESSARILY EQUAL TO } f_y. \right)$$

$f'_s \leq f_y$ IS CRITERIA.

Figure 9-5. Rectangular member, bending with axial tensile load, where $M_u/P_u < (d - h/2)$

and λ is 0.25 for hydraulic structures, compared to a value of 0.75 allowed by the ACI Building Code. Equation 9-13 is valid only for flexure.

(b) Design aids that will provide essentially the same results as the equations given in Figures 9-2 through 9-5 may be found in ACI publication SP-17. These will be valid for hydraulic structures so long as λ does not exceed 0.25 and the allowable capacity of the cross section is limited by flexural tension. Computer program CSTR (X0066) can assist in the design or investigation of strength of members in hydraulic structures (Appendix O).

d. Structures Not Subject to Hydraulic Action--Strength and Serviceability. The strength and serviceability requirements for structures not subject to hydraulic action should be in accordance with the current ACI Building Code. Computer program CASTR (X0067) can assist in the design or investigation of strength of members in walls not subject to hydraulic action (Appendix O).

e. Structures Not Subject to Hydraulic Action--Reinforced Concrete Design. Limits on strain, reinforcement, and concrete stress should be in accordance with the current ACI Building Code.

f. Shear Strength. The shear strength V_c provided by concrete should be computed in accordance with the ACI Building Code requirements. For cantilever retaining walls the maximum factored shear force should be computed at a distance d from the base of the stem for stem design, at a distance d from the stem for toe design, at the face of the stem for heel design, and at the top of the key for key design. Wherever an L-shaped wall without a toe is used, the shear force should be computed at the base of the stem for stem design and at the face of the stem for heel design.

9-9. Foundation Analyses. Foundation analysis should be performed in accordance with the methods described in Chapters 4 and 5 and illustrated in Appendix N. Concrete design should be for earth pressures corresponding to loading conditions which produce maximum tension in the respective elements of the foundation slab based on factored ultimate loads. The loading conditions corresponding to $SMF = 2/3$ should be considered as a minimum for single wedge analysis. This does not preclude the use of any other rational method of analysis that will produce an equivalent design.

CHAPTER 10

ALTERNATE TYPES OF RETAINING WALLS

Section I. Introduction

10-1. Classes of Retaining Walls. The four basic classes of retaining walls are gravity, cantilever, anchored, and mechanically stabilized backfill. Gravity walls rely on the weight of the wall system to resist overturning. The cantilever wall is fully reinforced to resist applied moments and shears. Anchored walls resist lateral forces primarily by the use of tieback anchors. Mechanically stabilized backfill involves the inclusion of reinforcement in the soil to form a coherent mass (Godfrey 1984, Mitchell, Villet, and DiMillio 1984, and Jones 1985).

10-2. Alternate Types of Retaining Walls. As discussed previously in Chapter 2, the most common types of retaining walls are gravity and cantilever walls constructed of cast-in-place concrete. Recently, however, a number of wall systems utilizing mechanically stabilized backfill as well as new types of gravity walls have been developed (Godfrey 1984). This chapter briefly describes mechanically stabilized backfill systems and precast concrete modular systems. The mention of any specific wall system does not constitute an endorsement or approval. Numerous wall systems are available and should be considered when appropriate. This manual does not attempt to provide complete design and/or construction procedures for the types of walls described in this chapter. Normally, design and construction procedures are provided by the manufacturer. However, the manufacturer normally provides only part of the design. The design engineer must assure the overall adequacy of the design.

Section II. Mechanically Stabilized Backfill Systems

10-3. General Background. Reinforced soil is a construction material composed primarily of soil with a performance that has been improved by the introduction of small quantities of other materials. These materials are in the form of strips, grids, sheets, rods, or fibers which strengthen the soil to resist tensile forces that soil alone is unable to withstand (Al-Hussani and Perry 1976 and Collin 1986).

10-4. Available Systems. Several mechanically stabilized backfill systems are available for retaining walls (Mitchell and Villet 1986).

a. Basic Components. Mechanically stabilized backfill systems have three major components: reinforcements, soil backfill, and facing elements. Both metallic and nonmetallic (geotextile, plastic) materials have been used for reinforcement. Granular material is normally used for soil backfill to meet stress transfer, durability, and drainage requirements. Facing elements are used to retain backfill material at the face of the wall, to prevent erosion of steep faces, and for aesthetic reasons. The facings are designed to resist only small horizontal earth pressures. Facing materials commonly used include precast concrete panels, prefabricated metal sheets and plates, welded

29 Sep 89

wire mesh, inclusion of intermediate reinforcements between main reinforcement layers at the face, and seeding of the exposed soil.

b. Basic Mechanisms and Behavior. The two primary mechanisms of stress transfer between the reinforcement and soil are friction between plane contact surface areas and passive soil-bearing resistance on reinforcement surfaces oriented transverse to the direction of movement. Strip, sheet, and rod reinforcements transfer stresses to the soil by friction, while grid reinforcements transfer stresses primarily by passive resistance. Geogrid reinforcements develop both frictional and passive soil resistance.

c. Strip Reinforcement. With strip reinforcement, a mechanically stabilized backfill is created by placing strips in horizontal planes between successive lifts of soil backfill. Reinforced earth, shown schematically in Figure 10-1, is a strip reinforcement system.

d. Grid Reinforcement. Grid reinforcement systems are formed by placing metallic or polymeric tensile resistant elements in horizontal planes in the soil backfill. Retaining walls using bar-mesh reinforcement have been constructed by the California Department of Transportation, Hilfiker Retaining Walls; VSL Corporation, and the Georgia State Highway Department (see Figures 10-2 and 10-3). Grid reinforcements are also made of polymer materials, such as Tensar Geogrid (see Figure 10-4).

10-5. Advantages and Disadvantages. The advantages and disadvantages of mechanically stabilized backfill systems are outlined below (Mitchell and Villet 1986).

a. Advantages.

(1) Mechanically stabilized backfill systems are economical when compared to conventional retaining walls.

(2) Construction of mechanically stabilized backfill systems usually is easy and rapid. It does not require skilled labor or specialized equipment. Many of the components are prefabricated allowing relatively quick construction.

(3) Regardless of the height or length of the wall, the structure remains stable during construction.

(4) When compared to conventional retaining walls, mechanically stabilized backfill systems are relatively flexible and can tolerate large lateral deformations and large differential vertical settlements (when this is anticipated, vertical sliding joints can be installed at intervals to compensate for movement). The flexibility of mechanically stabilized backfill systems allows the use of a lower factor of safety for bearing capacity design than conventional more rigid structures.

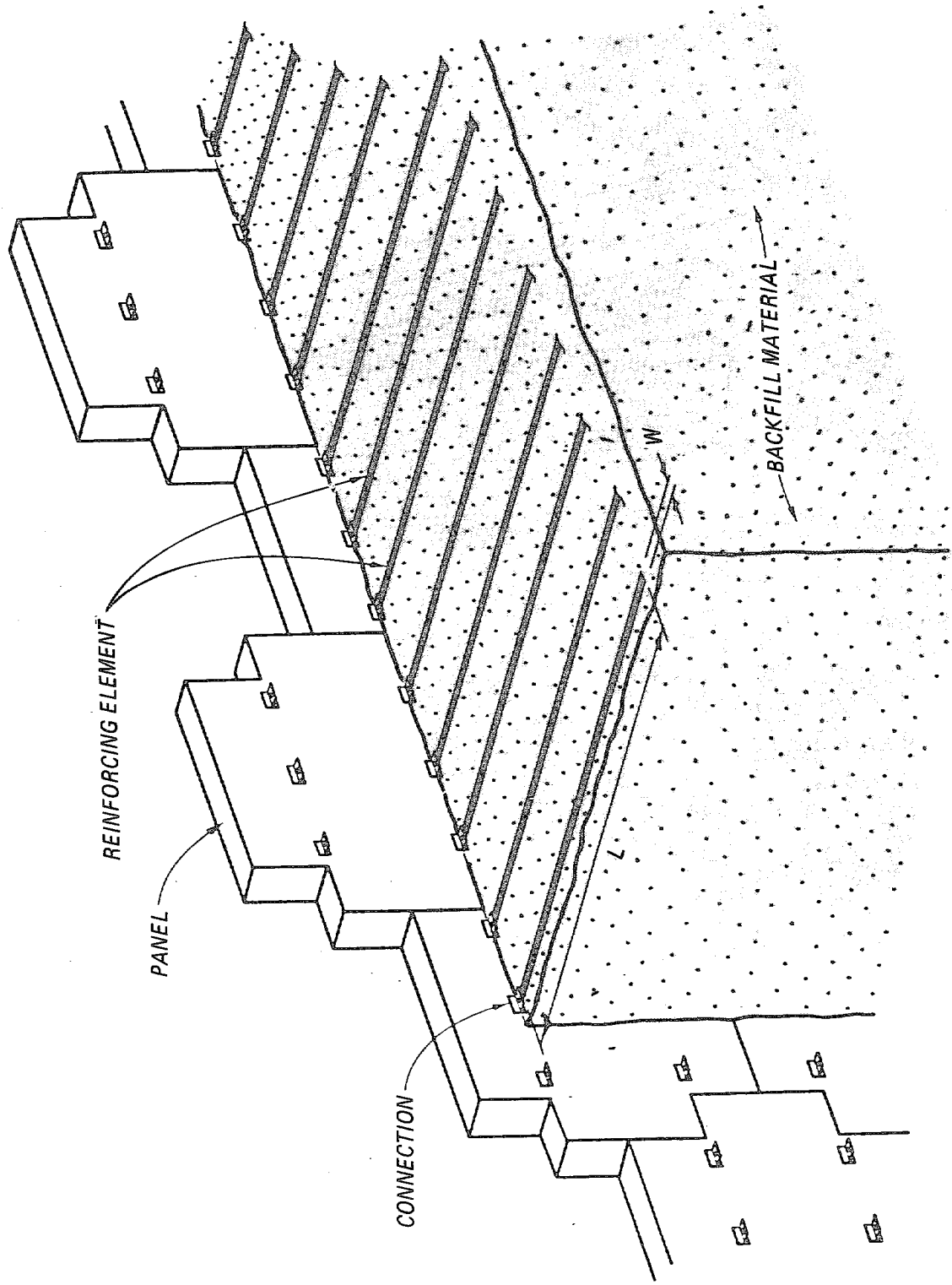

Figure 10-1. Schematic diagram of reinforced earth retaining wall

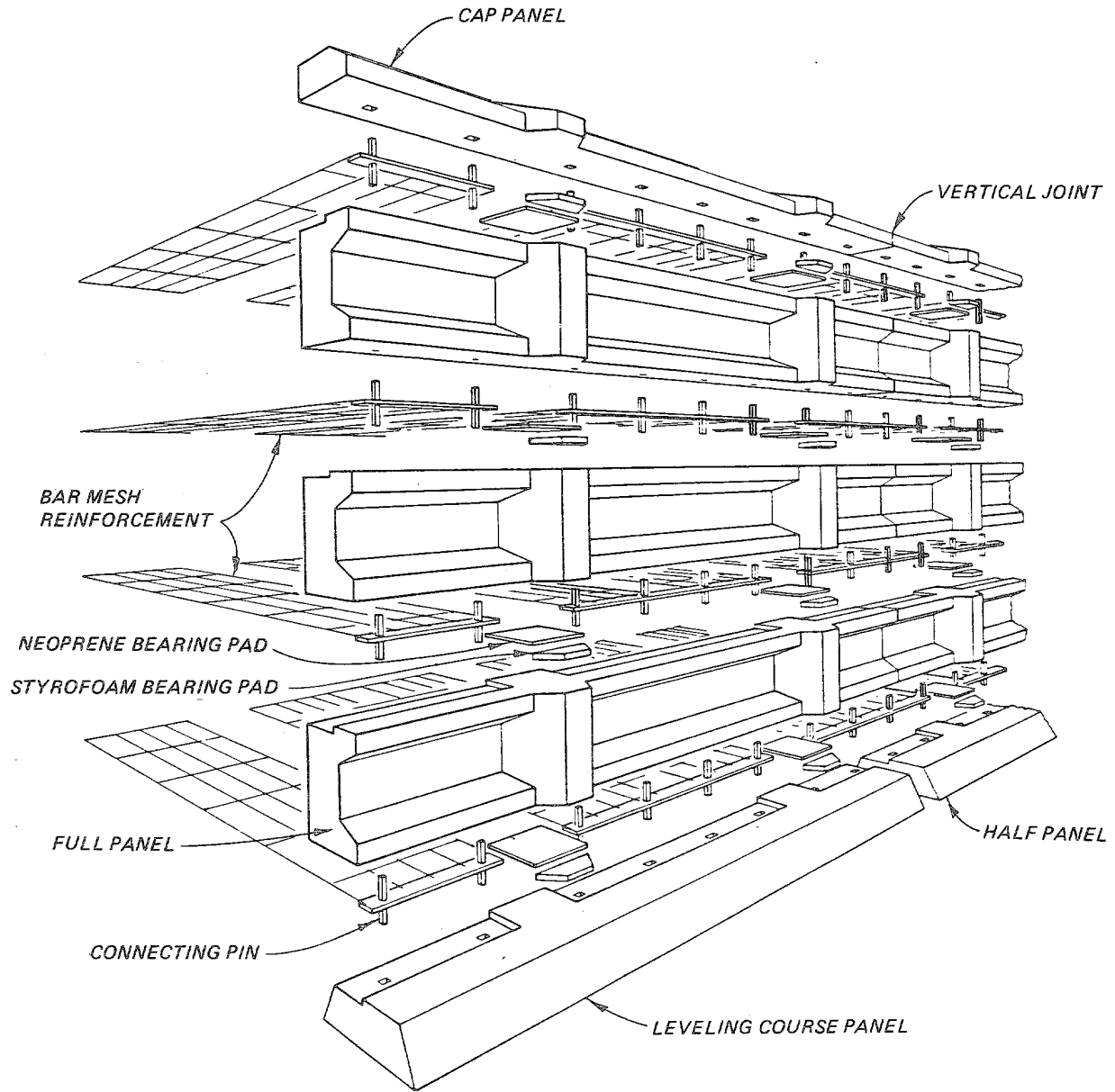

Figure 10-2. Schematic diagram of reinforced soil embankment retaining wall (after Hilfiker Company)

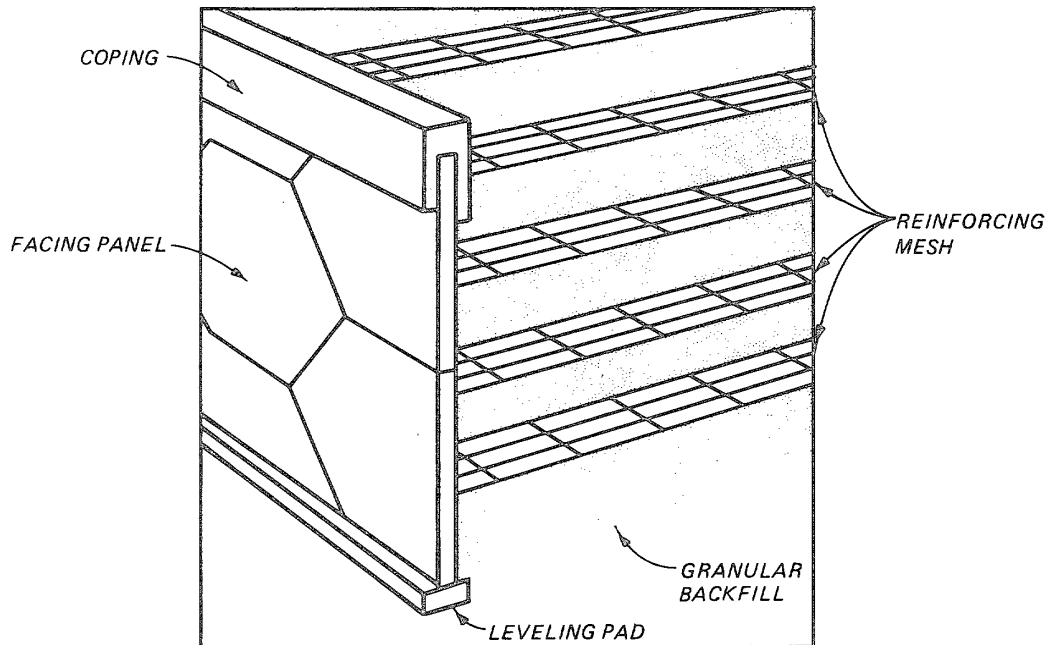

Figure 10-3. VSL retained earth retaining wall (adapted from VSL Corporation 1984)

(5) Mechanically stabilized backfill systems are potentially better suited for earthquake loading than conventional retaining walls because of the flexibility and inherent energy absorption capacity of the coherent earth mass. In designing mechanically stabilized backfill systems for earthquake regions, provision should be made for slippage of reinforcement elements rather than tension failure of the elements, resulting in a ductile structure (McKittrick 1979).

(6) Mechanically stabilized backfill systems, because of their flexibility and mass, are capable of withstanding dynamic loads imposed by wheel loads, wave action, and impact of small boats.

(7) Polymeric reinforcements are stable under chemical and biological conditions normally occurring in soils.

(8) Since facing elements play only a secondary structural role, a greater flexibility is available to meet aesthetic requirements than for conventional retaining walls. Facing arrangements range from concrete panels of

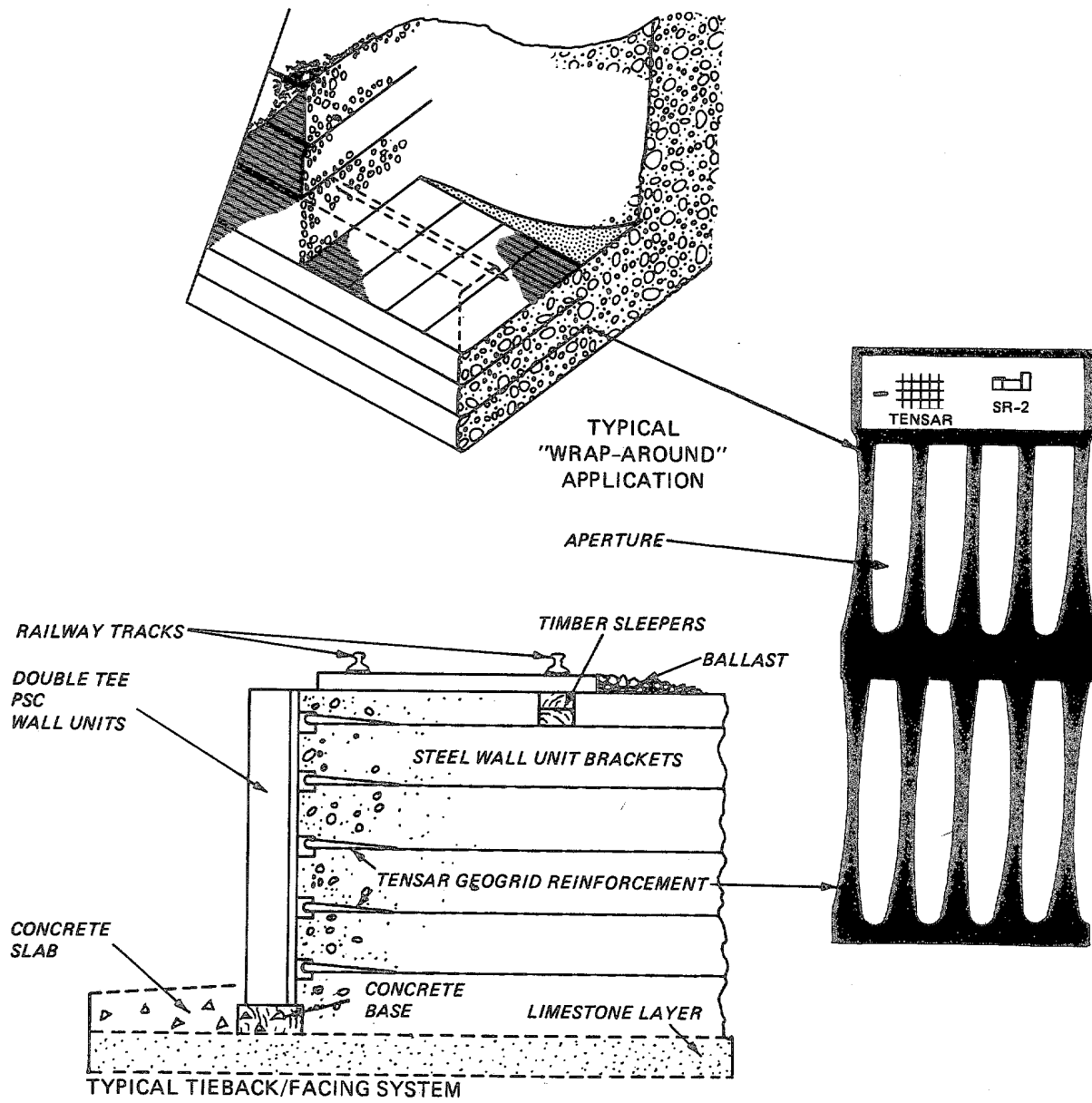

Figure 10-4. Tensar geogrid retaining wall (adapted from Tensar Corporation 1984)

various shapes, textures, and colors to provision of vegetation at the exposed face of the soil.

b. Disadvantages.

(1) Corrosion of metallic reinforcement occurs and must be assessed on a project basis by determining the potential aggressiveness of the soil. Special coatings such as galvanized zinc and resin-bonded epoxy are used with a sacrificial thickness of steel added in the design to give the required service life.

(2) Although polymeric reinforcement is a robust material, some allowance must be made for decrease in strength due to abrasion during construction. This will vary with the type of reinforcement material.

(3) Different polymers have different creep characteristics. Allowable loads in the grid should be selected based on allowable deformations, as well as the results of creep tests (10,000 hour). See McGown et al., 1985, for load-strain-time behavior of Tensor geogrids.

(4) The construction of mechanically stabilized embankments in cut regions requires a wider excavation than conventional retaining walls.

(5) Excavation behind the mechanically stabilized wall is restricted.

10-6. Cost Considerations. Mechanically stabilized backfill systems are particularly economical when compared to conventional retaining walls for earth fill situations where the retaining wall has a total surface area greater than 2,000 sq ft, average wall height greater than 10 feet, or where a rigid conventional wall requires a deep foundation for support. Precast concrete modular systems are cost-effective compared to conventional retaining walls for cut sides of excavations where the wall surface area is greater than 500 sq ft and average wall height is greater than 8 feet. The cost effectiveness of mechanically stabilized backfill systems will probably be reduced by high-cost backfill, complicated horizontal alignment, or the necessity of providing temporary excavation support systems during construction. For excavated side slopes, mechanically stabilized backfill systems can be constructed for 30 to 50 percent less than conventional retaining walls. However, a short life, serious consequences of failure, or high repair or replacement costs could offset a lower first cost. Similar savings in construction time are obtained using mechanically stabilized backfill systems, according to Leary and Klinedinst (1984).

10-7. Mechanisms and Behavior. The stability of mechanically stabilized backfill systems depends on transfer of stresses between the soil and reinforcements. Most reinforcements are inextensible in that they rupture at strains much less than those required to cause soil failure* (Mitchell and Villet 1986, Mitchell, Villet, and DiMillio 1984).

29 Sep 89

a. Mechanisms. The transfer of stress between soil and reinforcement is by friction and/or passive soil resistance when the reinforcement is loaded in tension. In many reinforcement systems both mechanisms are present, and the relative contribution of each is indeterminate.

(1) Friction. The load transferred by friction per unit area of reinforcement depends on the interface characteristics of the soil and reinforcement, and on the normal stress between them, which in turn depends on the stress-deformation behavior of the soil. This latter behavior is itself stress-dependent. Therefore, the effective friction coefficient cannot be estimated by analytical procedures. The results of experiments such as pullout tests, direct shear tests between soil and reinforcements, and instrumented model and full-scale tests, are often used to select friction coefficients. The coefficient of friction is defined as the average mobilized shear stress along the reinforcement divided by the normal stress from the overburden pressure. Empirical data from pullout tests on strip reinforcements show a decrease in this coefficient with depth regardless of the type of reinforcement (smooth or ribbed). This occurs because the effective normal stress is altered by the soil to reinforcement interaction. As shear strains are imposed on a dense granular soil, the soil tends to dilate. If the tendency to dilate is partially restrained by boundary conditions, local confining stresses will increase with the tendency to dilate decreasing as the confining stress increases. Hence, the influence of dilatancy on friction coefficients computed from pullout tests decreases with depth. Therefore, since the influence of dilatancy decreases with depth, the coefficient of friction also decreases with depth. Also, recent experience in construction with granular soils of low uniformity coefficients** (less than 4) indicates a relatively low friction coefficient (≈ 1.0) for these types of granular soils.

(2) Passive Soil Resistance. Passive soil resistance to pullout of reinforcement develops against bearing surfaces which are normal to the direction of the pullout force. For grid reinforcing systems with the spacing of cross bars parallel to the wall equal to or greater than 6 inches, the major portion of the resistance (approximately 90 percent for bar mesh in a sandy gravel) is obtained by passive soil resistance or bearing capacity on the front face of elements oriented transverse to the pullout force direction.

(3) Strain Compatibility. Friction between the soil and a smooth reinforcement requires a small displacement of about 0.05 inch. Passive soil

* Some geotextiles, which require large deformations to cause failure, are the exception.

**

$$C_u = \frac{D_{60}}{D_{10}}$$

where C_u = coefficient of uniformity

D_{60} = grain diameter at 60 percent passing

D_{10} = grain diameter at 10 percent passing

resistance against surfaces normal to displacement requires relative soil-to-reinforcement displacements as large as 4 inches for complete mobilization. However, a significant portion (greater than 50 percent) of the maximum value is mobilized at deflections of about 0.25 inch (Elias 1986). For bar mat grid reinforcement systems, the small beneficial effects of friction are neglected in view of possible strain incompatibility between frictional behavior and passive soil resistance.

b. Behavior. The distribution of lateral earth pressure within reinforced soil depends on the extensibility of the reinforcements, the construction methods used, and the type of reinforced structure. The active horizontal stress state is used for systems which are able to undergo relatively large lateral deformations, such as geotextiles. Higher lateral stresses, such as at-rest pressures, are associated with less extensible reinforcements, e.g., steel strips, bar meshes, welded wire mesh, and relatively low confining pressures, e.g., at shallow depths in the soil backfill where dilatancy is most effective. Under low confining stresses a reinforcement system may fail by pullout between the reinforcement and soil. Under high confining stresses the same system may fail by breakage of the reinforcements.

10-8. Materials. As previously mentioned, the three basic components of mechanically stabilized backfill systems are reinforcements, soil backfill, and facing elements (Mitchell and Villet 1986).

a. Reinforcement. The reinforcements may be characterized by the type of material (metallic and nonmetallic) and geometry (strips, grids, and sheets). Important material properties for reinforcements are strength and stability (low tendency to creep), high coefficient of friction with soil backfill, and durability. Depending on the electrochemical properties of the soil backfill and structure environment (marine or freshwater, presence of stray electrical currents in the ground, etc.) galvanized zinc-coated steel, resin-bonded epoxy-coated steel, or polymeric reinforcements are used. Polymeric reinforcements are not subject to corrosion but do exhibit creep characteristics (decrease in strength with time at constant load and soil temperature).

b. Soil Backfill. Most mechanically stabilized embankment systems have used cohesionless soil backfill. However, since grid reinforcements have a much greater pullout resistance than strip reinforcements, it is possible to construct mechanically stabilized embankment systems using silty or clayey material as backfill (Forsyth 1979 and Jackura 1984). The advantages of cohesionless soil backfill are that it is stable (will not creep), free-draining, not susceptible to frost, and relatively noncorrosive to reinforcement. The main disadvantage, where cohesionless soil has to be imported, is cost. The main advantage of cohesive soils is availability and hence lower cost. The disadvantages are long-term durability problems (corrosion and/or frost susceptibility) and distortion of the structure (due to creep of the soil backfill). When cohesionless soil backfill is readily available it should be used. When it is not readily available, the costs of importing cohesionless

29 Sep 89

soil backfill should be weighed against the potentially poorer performance of using the lower-cost locally available cohesive soil backfill.

c. Facing Elements. Since facing elements play only a secondary structural role, a greater flexibility in choice of materials is available to meet aesthetic requirements than is the case for conventional retaining walls. A wide variety of materials, shapes, architectural finishes, and colors are available for facing elements. Selecting among these depends on the function of the structure, type of reinforcement, and aesthetics.

10-9. Design Considerations. The various engineering companies involved in a project provide site-specific designs for their proprietary system. Mechanically stabilized embankment systems must be designed for both external and internal stability. External stability is evaluated in a manner similar to a conventional gravity retaining wall. Internal stability depends on there being neither pullout nor breakage of the reinforcement (Mitchell and Villet 1986, Collin 1986).

a. External Stability. The mechanically stabilized backfill system must be stable against sliding along the base of the structure, overturning about the toe of the wall, bearing capacity failure of the foundation soil, overall slope stability, and differential settlement along the structure. For external stability calculations the mechanically stabilized backfill system is assumed to behave as a coherent block.

(1) Sliding Along the Base of the Structure. The mechanically stabilized backfill system must be stable against sliding due to the lateral pressure of the soil retained by the system. The minimum factor of safety against sliding should be 1.5. Sliding considerations may govern the design for high structures (greater than 30 feet) or structures with sloping backfills.

(2) Overturning About the Toe of the Wall. The mechanically stabilized backfill system must be stable against overturning about the toe of the wall. Since in reality the structure is flexible, it would probably never fail by overturning. One hundred percent of the base should always be in contact with the subgrade for all loading conditions (Elias 1986). Overturning considerations seldom govern the design of structures when the minimum reinforcement length is 70 percent of the wall height.

(3) Bearing Capacity Failure and Settlement. The mechanically stabilized backfill system must be stable against bearing capacity failure of the foundation soil. The minimum factor of safety against bearing capacity failure should be 2.0. This is lower than that used for conventional retaining walls (see Table 4-1) because of the flexibility of the mechanically stabilized backfill system and its ability to function satisfactorily after experiencing large differential settlements. If the foundation does not meet stability requirements, consideration should be given to ground improvement techniques such as stone columns, vibroflotation, and dynamic compaction to improve foundation stability. The maximum allowable differential settlement of mechanically stabilized backfill systems is limited by the longitudinal

deformability of the facing and the purpose of the structure. For precast concrete panels, without built-in vertical joints,* the limiting tolerable differential settlement is 1 foot per 100 feet of wall length.

(4) Overall Slope Stability. The mechanically stabilized backfill systems, retained soil, and foundation should be stable against slope failure. All potential slip surfaces should be investigated including those passing through the reinforcement and deep-seated sliding. The minimum factor of safety for slope stability should be 1.5.

b. Internal Stability. The mechanically stabilized backfill system must be stable against reinforcement pullout and reinforcement breaking.

(1) Reinforcement Pullout. In determining the reinforcement pullout capacity, the effective length of reinforcement behind the theoretical failure surface must be great enough to assure the transfer of stress from the reinforcement to the backfill soil without reinforcement pullout. The resistance to pullout may be frictional (strip reinforcement), passive (bar mesh reinforcement), or frictional-passive (Geogrid). Using data from laboratory pullout tests at a maximum of 0.75 inch of deformation, the structure should be designed with a minimum factor of safety against reinforcement pullout of 1.5 at each reinforcement level.

(2) Reinforcement Breaking. To assure a sufficient reinforcement breaking capacity, the effective cross-sectional area of the reinforcement (corrected for corrosion effects over the design life of the structure) must be great enough to allow for the transfer of stress from the reinforcement to the backfill soil without the reinforcement breaking. The design stress in the reinforcement should be taken as 55 percent of the yield stress (Elias 1986).

(3) Durability of Reinforcements. The durability of reinforcements, over the design life of the structure, is an important design consideration. Deterioration of polymeric reinforcements may occur due to abrasion during construction and decrease in strength with time at constant load and soil temperature. Corrosion of metallic reinforcement occurs due to exposure to air, water, and chemicals in the soil backfill. Galvanized zinc-coated steel (with a sacrificial thickness of steel added to give the required service life) is often used for reinforcing mild to moderately corrosive soil backfill with the following properties** (Frondistou-Yannas 1985).

Resistivity > 3,000 ohm-centimetres

pH 5-10

* Hilfiker Reinforced Soil Embankment retaining walls have vertical joints built into the wall every 12.5 feet and can tolerate large differential settlements.

** Galvanized zinc-coated steel should not be used if the soil backfill contains illite clay because zinc is sensitive to illite.

Chlorides < 200 parts per million

Sulfates < 1,000 parts per million

For mild to moderately corrosive soil backfills the corrosion loss rates are:

Galvanization 6 $\mu\text{m}/\text{year}$ for first 2 years

2.5 $\mu\text{m}/\text{year}$ for subsequent years

Steel 9 $\mu\text{m}/\text{year}$ after all zinc is lost

The use of aluminum and stainless steel reinforcement is not recommended as several failures have occurred using these materials (McGee 1985). For structures exposed to marine environments, stray electrical currents in the ground, or with soil backfill properties outside the electrochemical guidelines previously given, resin-bonded epoxy-coated metallic reinforcements or a conventional or precast concrete modular gravity wall should be used. A minimum epoxy coating thickness of 18 mils is necessary to survive transportation and installation, and to provide an acceptable level of design confidence. When epoxy-coated metallic reinforcement is used, the soil backfill should consist of rounded stone with a maximum particle size of 1 inch. For design purposes, the life of the epoxy coating should be assumed to be the same as a galvanized zinc coating of 2 oz/sq ft, or 30 years. A sacrificial thickness of steel should be added to provide the epoxy-coated reinforcement an adequate factor of safety at the design life of the structure (Frondistou-Yannas 1985, Jones 1985).

c. Drainage. Drainage measures must be considered for all mechanically stabilized backfill systems to prevent saturation of the soil backfill and to intercept surface flows containing aggressive elements such as deicing chemicals. When mechanically stabilized backfill systems support roadways which are chemically deiced in the winter, an impervious membrane should be placed between the pavement and the first row of metallic reinforcements to intercept any surface flows containing aggressive chemicals.

10-10. Construction Considerations. The construction of mechanically stabilized embankment systems does not require specialized contractors, skilled labor, or special equipment. Many of the components are prefabricated, providing ease of handling and forming and relatively quick construction. A small crane is used to handle and erect precast concrete facing panels. Front end loaders are used for loading dump trucks and spreading the soil backfill. Vibratory rollers are used to compact the soil backfill while small hand-operated compactors are used for compaction near the wall face. Preparation of the construction area consists of clearing vegetation, debris, and other deleterious material from the site. A concrete leveling pad, which is not a structural member, is constructed to facilitate the erection of the concrete panels. The first layer of soil backfill is placed and compacted and the reinforcement is laid on the surface of the compacted fill and covered with the next layer of fill. Construction equipment must not run on top of the

reinforcement. Concrete panels are battered to the inside to compensate for the small outward movement to mobilize the resistance of the reinforcement. Filler material (cork, styrofoam, neoprene, etc.) is used between all horizontal joints to provide a uniform bearing surface between adjacent panels. A geotextile is placed over all joints on the fill side of the concrete panels to prevent fines from migrating from behind the wall (Mitchell and Villet 1986).

10-11. Instrumentation and Monitoring. The history of mechanically stabilized embankment systems is relatively short compared to the design life of the structure.* Therefore, continued accumulation of field data on a full-scale structure is necessary to verify design assumptions. Structures should be instrumented and monitored whenever atypical conditions exist such as cohesive soil backfill, epoxy-coated metallic reinforcement, or adverse groundwater conditions (outside the range specified in paragraph 10-9b(3)). Measurements should be made of horizontal and vertical displacements of the wall facing; soil pressures on the facing or on a vertical plane near the facing, the base of the wall, and perpendicular planes (horizontal and vertical) along the anticipated maximum tensile force line; tensile forces in the reinforcement including near the locus of maximum tensile force and near the wall facing; and pullout tests on short reinforcements. All mechanically stabilized embankment structures should be monitored once they are placed in operation to ensure stability. External stability of the mechanically stabilized embankment structure could be threatened by the same factors as a conventional retaining wall; e.g., clogging of the drainage system, erosion at the toe of the wall, etc. However, the mechanically stabilized embankment system could also fail due to changes in conditions which adversely influence the internal stability of the system. These include excavation within the soil backfill, changes in the groundwater conditions (outside the range specified in paragraph 10-9b(3)), and possible damage to the stabilizing ties because of vandalism to the exposed structure (Mitchell and Villet 1986, Al-Hussani and Perry 1978).

10-12. Maintenance and Repair. Since mechanically stabilized embankment systems are relatively new there is very limited field experience regarding maintenance and repair. Maintenance problems arising with facing elements could be repaired by conventional methods since the facing elements play a secondary role and resist only small horizontal earth pressures (Long et al. 1984). However, problems with the reinforcements, such as corrosion of metallic reinforcements, would be difficult to repair. One possible solution would be to use soil nailing to stabilize the structure (Jones 1985). Another method would be to place a stone buttress in front of the structure (Mitchell and Villet 1986).

* Strip reinforcement was first utilized in U.S. construction in 1972, bar mesh reinforcement in 1975, and Geogrid reinforcement in 1984.

Section III. Precast Concrete Modular Systems

10-13. Background. Precast concrete modular systems consist of interlocking soil-filled reinforced concrete modules which form a gravity retaining wall. They can be erected rapidly and are cost-competitive with mechanically stabilized backfill systems.*

10-14. Basic Components. The basic components of precast concrete modular systems are interlocking precast reinforced concrete modular elements filled with soil and resting on natural soil or a concrete foundation (see Figures 10-5 to 10-8). Some systems have resets or an open-face structure at the wall face (see Figures 10-7 and 10-8) with evergreen vegetation to reduce noise levels and eliminate the problem of graffiti.

10-15. Advantages and Disadvantages. The advantages and disadvantages of precast concrete modular systems are listed below.

a. Advantages.

(1) Modular systems are economical when compared to conventional retaining walls in cut situations, particularly where the retaining wall has a total surface area greater than 500 sq ft and average wall heights greater than 8 feet.

(2) Assembly of the wall components requires no fasteners and the modules may be reused easily and economically.

(3) The precast concrete modular retaining wall does not utilize reinforcing elements and therefore is not subject to corrosion damage.

(4) Excavation behind the precast concrete modular retaining wall does not adversely influence the stability of the system as might occur for the mechanically stabilized wall.

b. Disadvantage. The precast concrete modular retaining wall could sustain cracking of interior connecting members due to relatively small (0.5 foot per 100 feet of wall length) longitudinal differential settlement.

10-16. Design Considerations. Various engineering companies involved will provide site-specific plans and limited designs for their proprietary system. Stability is evaluated in a manner similar to a conventional gravity retaining wall. For stability calculations the interlocking precast concrete modular system is assumed to behave as a coherent block. The system must be stable

* For certain applications, such as where large differential vertical settlements are anticipated, consideration should be given to steel-bin type retaining walls which are generally more expensive than mechanically stabilized backfill or precast concrete modular systems but less expensive than conventional retaining walls.

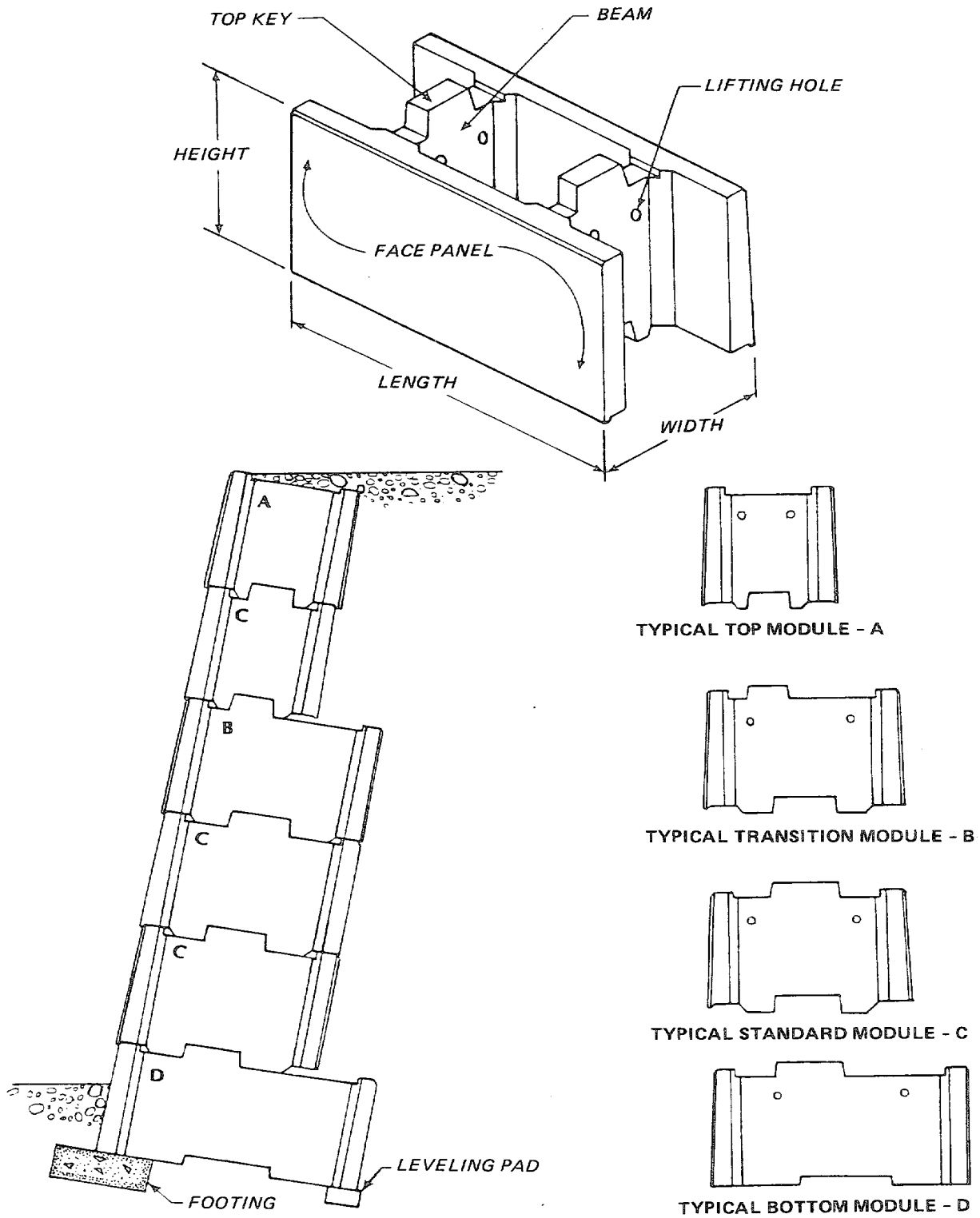

Figure 10-5. Schematic diagram of Doublewal retaining wall (after Doublewal Corporation 1984)

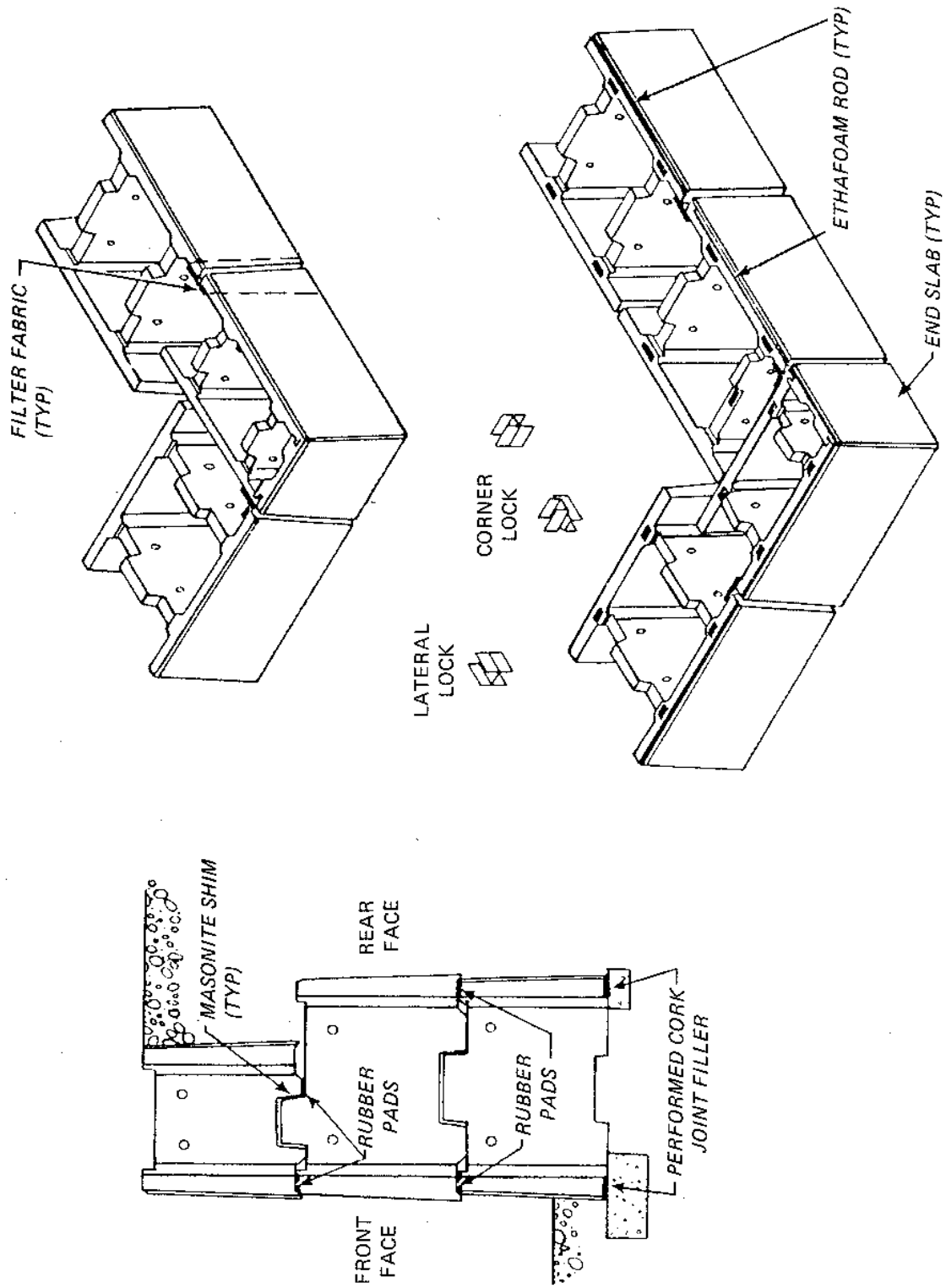

Figure 10-6. Materials used to construct Doubleweal retaining wall
(after Doubleweal Corporation 1984)

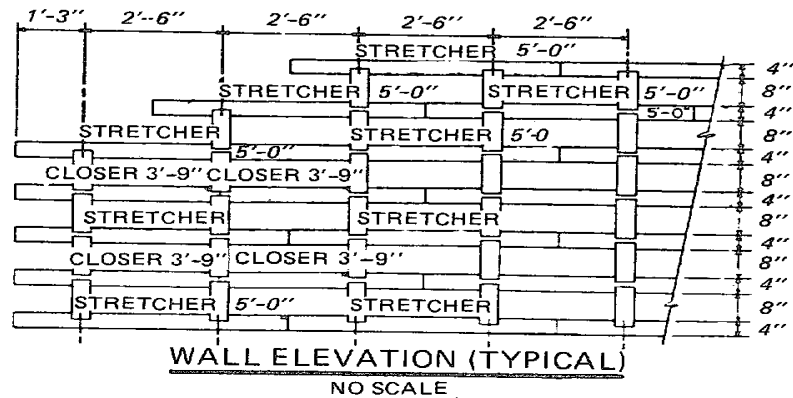
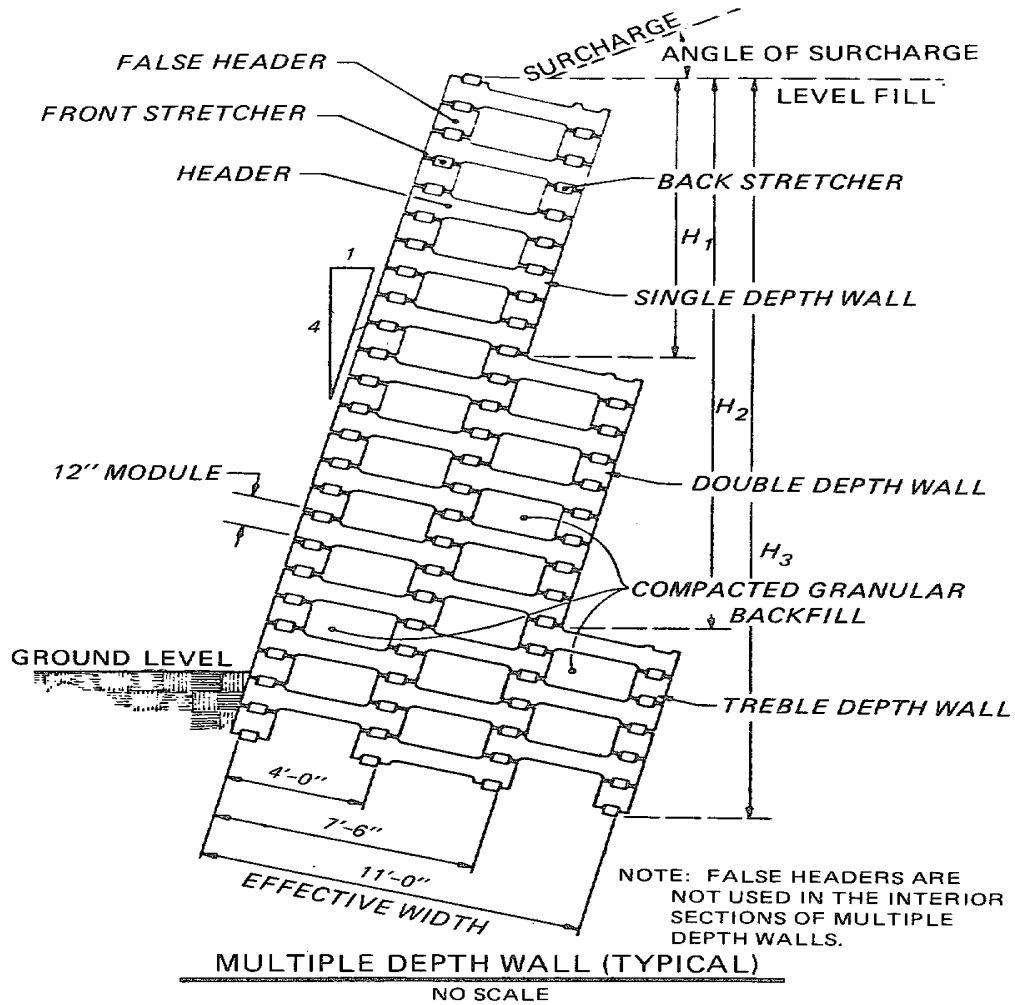

Figure 10-7. Schematic diagram of Criblock retaining wall (after Criblock Retaining Walls of America)

RETAINING WALL

FOUNDATION DIMENSIONS

- a = TRENCH WIDTH
- b = LENGTH
- c = LEDGE
- d = DEPTH
- f = FROST DEPTH
- P = PEDESTAL OR PIER
- F = FOOTINGS

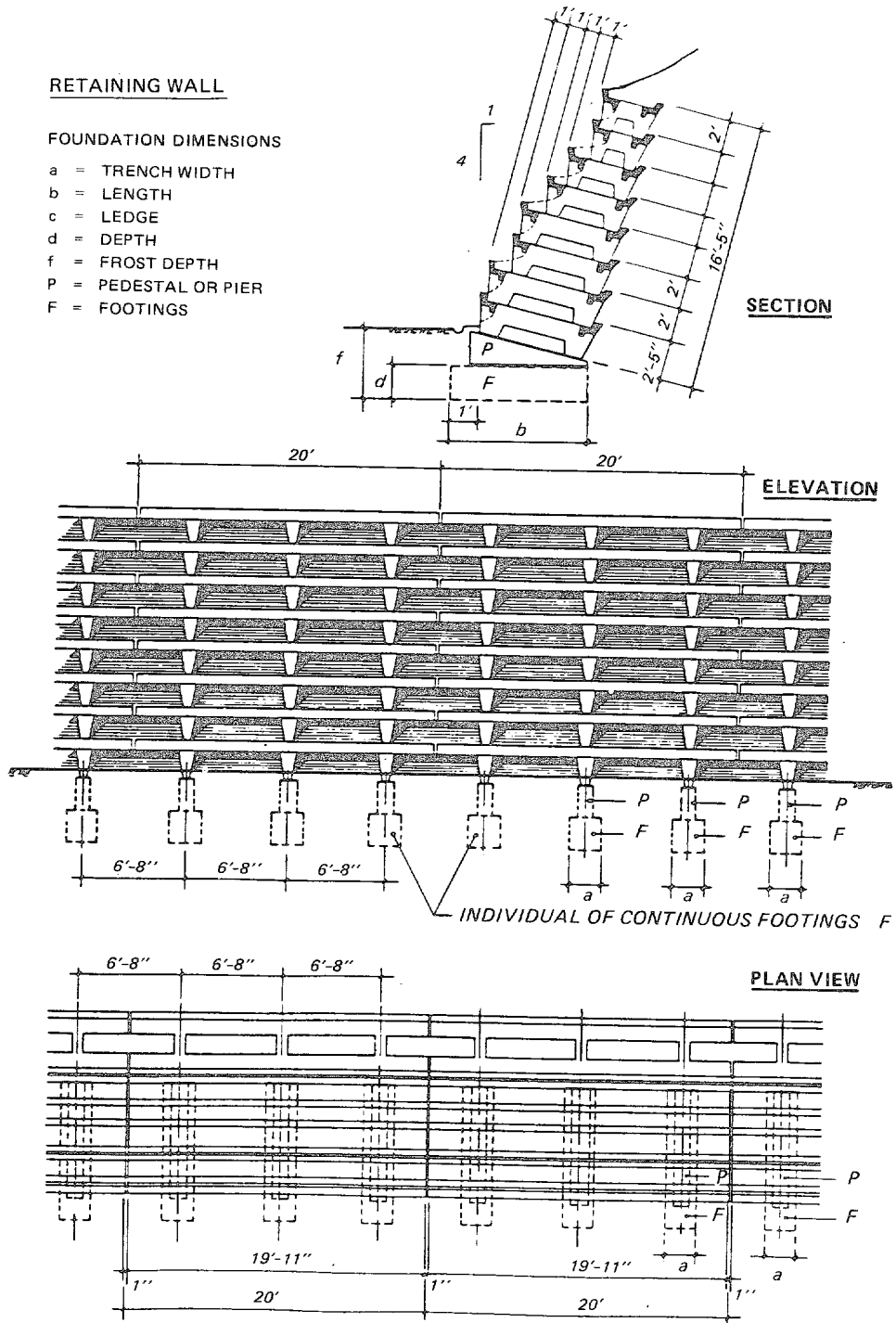

Figure 10-8. Schematic diagram of Evergreen retaining wall (after Evergreen Systems, Inc.)

against sliding along the base of the structure, overturning about the toe of the wall, bearing capacity failure of the foundation soil, differential settlement, and overall slope stability.

a. Sliding Along The Base Of The Structure. The precast concrete modular system must be stable against sliding due to the lateral pressure of the soil retained by the system. The minimum factor of safety against sliding should be 1.5.

b. Overturning About The Toe Of The Wall. The precast concrete modular system must be stable against overturning about the toe of the wall. Since the concrete modular units are not tied together vertically, the stability against overturning must be checked at each concrete module level for a given width. One hundred percent of the base should always be in contact with the subgrade for all loading conditions (Elias 1986). Normally overturning (not sliding) criteria govern the design.

c. Bearing Capacity Failure and Settlement. The precast concrete modular system must be stable against bearing capacity failure of the foundation soil. The minimum factor of safety against bearing capacity failure should be 3.0 (Elias 1986). If the foundation does not meet stability requirements, consideration should be given to use of a mechanically stabilized backfill system or ground improvement techniques such as stone columns, vibroflotation, and dynamic compaction to improve foundation stability. As previously stated, the precast concrete modular retaining wall could sustain cracking of interior connecting members due to relatively small (0.5 foot per 100 feet of wall length) longitudinal differential settlement. Precast concrete modular retaining walls are also susceptible to damage from differential settlement perpendicular to the wall face, particularly on high walls where the bottom wall units may be as wide as 20 feet.

d. Overall Slope Stability. The precast concrete modular system, retained soil, and foundation should be stable against slope failure. All potential slip surfaces should be investigated including deep-seated sliding. The minimum factor of safety for slope stability should be 1.5.

e. Drainage. Drainage measures must be considered for all precast concrete modular systems to prevent saturation of the soil backfill. Also, for closed-face modular systems (see Figure 10-5), a geotextile is placed over all joints on the back side of the front face of the wall to prevent fines from migrating from behind the wall.

10-17. Construction Considerations. The construction of precast concrete modular systems does not require specialized contractors, skilled labor, or special equipment. The components are prefabricated providing ease of handling and forming and relatively quick construction. Soil backfill within the precast modular units should receive adequate compaction to minimize post-construction settlements.

29 Sep 89

10-18. Instrumentation and Monitoring. The history of precast concrete modular systems is relatively short compared to the design life of the structure.* Therefore, continued accumulation of field data is necessary to verify design assumptions. Structures should be instrumented and monitored whenever atypical conditions exist such as anticipated large differential vertical settlement. Measurements should be made of horizontal and vertical displacements of the front face of the wall and soil pressures on the rear face of the wall. All precast concrete modular structures should be monitored once they are placed in operation to ensure stability. Stability of the precast concrete modular structure could be threatened by the same factors as a conventional retaining wall; e.g., clogging of the drainage system, erosion at the toe of the wall, etc. Precast concrete modular structures should also be monitored for possible damage from differential settlements.

10-19. Maintenance and Repair. Since precast concrete modular structures are relatively new, there is very limited field experience regarding maintenance and repair. Possible methods of repair to a section of the structure which has sustained damage from differential settlement include replacing the section with a wall more tolerant to differential settlement, such as a mechanically stabilized embankment system with vertical joints (see Figure 10-2) or a steel-bin type wall, or placing a stone buttress in front of the structure.

* Criblock was first used in US construction in 1978, Doublewal in 1979, and Evergreen in 1986.

APPENDIX A

REFERENCES

Government Publications

Department of the Army, Corps of Engineers*

Engineer Regulations

ER 1110-1-803	Constructibility
ER 1110-2-100	Periodic Inspection and Continuing Evaluation of Completed Civil Works Structures
ER 1110-2-1806	Earthquake Design and Analysis for Corps of Engineers Projects
ER 1130-2-339	Inspection of Local Flood Protection Projects (RC5 DAEN-CWC-40)

Technical Manuals

TM 5-818-1	Soils and Geology: Procedures for Foundation Design of Buildings and Other Structures (Except Hydraulic Structures)
------------	---

Engineer Manuals

EM 1110-1-1804	Geotechnical Investigations
EM 1110-1-2101	Working Stresses for Structural Design
EM 1110-1-2009	Architectural Concrete
EM 1110-2-301	Landscape Planting at Floodwalls, Levees & Embankment Dams
EM 1110-2-1410	Interior Drainage of Leveed Urban Areas: Hydrology
EM 1110-2-1601	Hydraulic Design of Flood Control Channels

* Available from: Corps of Engineers Publication Depot, 2803 52nd Avenue, Hyattsville, MD 20781.

EM 1110-2-2502	
29 Sep 89	
EM 1110-2-1901	Soil Mechanics Design - Seepage Control
EM 1110-2-1902	Stability of Earth and Rock-Fill Dams
EM 1110-2-1903	Bearing Capacity of Soils
EM 1110-2-1904	Soil Mechanics Design - Settlement Analysis
EM 1110-2-1905	Design of Finite Relief Well Systems
EM 1110-2-1906	Laboratory Soil Testing
EM 1110-2-1907	Soil Sampling
EM 1110-2-1908	Instrumentation of Earth and Rock-Fill Dams (Ground-Water & Pore Pressure Observations) (Part 1)
EM 1110-2-1911	Construction Control for Earth and Rockfill Dams
EM 1110-2-1913	Design and Construction of Levees
EM 1110-2-2000	Standard Practice for Concrete
EM 1110-2-2102	Waterstops and Other Joint Materials
EM 1110-2-2103	Details of Reinforcement - Hydraulic Structures
EM 1110-2-2906	Design of Pile Structures and Foundations
EM 1110-2-4300	Instrumentation for Concrete Structures
EM 1120-2-109	Federal Participation in Major Drainage Improvements
Guide Specifications	
CW 02215	Plastic Filter Fabric
CW 03301	Cast-in-Place Structural Concrete
CW 03305	Mass Concrete

- Agostinelli, V. M., et al. 1981 (Feb). "Program Criteria Specifications Document for Computer Program TWDA for Design and Analysis of Inverted-T Retaining Walls and Floodwalls." Available from: U. S. Army Engineer Waterways Experiment Station, P. O. Box 631, Vicksburg, MS 39180.
- Al-Hussani, M. M., and Perry, E. B. 1976 (Sep). "Effect of Horizontal Reinforcement on Stability of Earth Masses," Technical Report S-76-11, U. S. Army Engineer Waterways Experiment Station, P. O. Box 631, Vicksburg, MS 39180.
- Al-Hussani, M. M., and Perry, E. B. 1978 (Mar). "Field Experiment of Reinforcement Earth Wall," Journal of the Geotechnical Engineering Division, ASCE, Vol 104, No. GT3, pp 307-322. Available from: U. S. Army Engineer Waterways Experiment Station, P. O. Box 631, Vicksburg, MS 39180.
- American Concrete Institute. "Building Code Requirements for Reinforced Concrete," ACI 318, Detroit, Mich. Available from: American Concrete Institute, P. O. Box 19150, Redford Station, Detroit, MI 48219.
- American Concrete Institute. 1967. "Ultimate Strength Design Handbook, ACI Publication SP-17. Available from: American Concrete Institute, P. O. Box 19150, Redford Station, Detroit, MI 48219.
- ANSI A58.1. Minimum Design Loads for Buildings and Other Structures, American National Structures Institute, Inc., 1430 Broadway; New York, NY 10018.
- Applied Technology Council (ATC). 1981 (Oct). Seismic Design Guidelines for Highway Bridges, FHWA Report No. FHWA/RD-81/081. Available from: NTIS, Springfield, VA 22161.
- ASTM D 1586. "Standard Method for Penetration Test and Split-Barrel Sampling of Soils." Available from: ASTM, 1916 Race St., Philadelphia, PA 19103.
- ASTM D 3441-79. "Standard Method for Deep Quasi-Static, Cone and Friction-Cone Penetration Tests of Soil." Available from: ASTM, 1916 Race St., Philadelphia, PA 19103.
- Baguelin, F., Jezequel, J. F., and Shields, J. F. 1978. The Pressuremeter and Foundation Engineering, Trans-Tech Publications, Rockport, MA.
- Bowles, J. E. 1982. Foundation Analysis and Design, 3rd ed., McGraw-Hill, New York.
- Brooker, E. W., and Ireland, H. O. 1965 (Feb). "Earth Pressures At-Rest Related to Stress History," Canadian Geotechnical Journal, Vol 2, No. 1, pp 1-15.

EM 1110-2-2502
29 Sep 89

- Caquot, A., and Kerisel, J. 1948. Tables for the Calculation of Passive Pressure, Active Pressure, and Bearing Capacity of Foundations (translated by M. A. Bec, London), Gauthier-Villars, Paris.
- Carroll, R. G., Jr., and Murphy, J. C. 1985 (May-Jun). "Drainage Objective: Prefabricated Drainage Composites," Geotechnical Fabrics Report, Vol 3, No. 3, pp 14-18.
- Casagrande, A. 1937. "Seepage Through Dams," Contributions to Soil Mechanics, 1925-1949, Boston Society of Civil Engineers, Boston, MA, pp 295-336.
- Casagrande, Leo. 1973 (Feb). "Comments of Conventional Design of Retaining Structures," Journal, Soil Mechanics and Foundations Division, American Society of Civil Engineers, Vol 99, No. SM 2, pp 181-197. Available from: ASCE Publication Fulfillment, 345 East 47th Street, New York, NY 10017.
- Cedergren, Harry R. 1967. Seepage, Drainage, and Flow Nets, John Wiley and Sons, New York.
- Collin, J. C. 1986 (May). "Earth Wall Design," Ph.D. Dissertation, University of California, Berkeley. Available from: University Microfilms International, 300 North Zeeb Road, Ann Arbor, MI 48106.
- Criblock Retaining Walls of America, Inc. "Criblock Interlocking Concrete Criblock." Available from: Criblock Retaining Wall of America, Inc., P. O. Box 849, Sierra Madre, CA 91024.
- Danish Geotechnical Institute. 1978. "Code of Practice for Foundation Engineering," Danish Geotechnical Institute, Copenhagen, Denmark, Bulletin No. 32, p 52.
- Das, B. M. 1984. Principles of Foundation Engineering, Brooks/Cole Engineering Division, Monterey, CA.
- Department of the Navy. 1982a (May). "Soil Mechanics," NAVFAC DM-7.1. Available from: Department of the Navy, Naval Facilities Engineering Command, 200 Stovall St., Alexandria, VA 22332.
- Department of the Navy. 1982b (May). "Foundations and Earth Structures," NAVFAC DM-7.2. Available from: Department of the Navy, Naval Facilities Engineering Command, 200 Stovall St., Alexandria, VA 22332.
- Doublewal Corp. 1984. "Doublewal Interlocking Precast Retaining Wall System Field Manual." Available from: Doublewal Corp., 59 East Main St., Plainville, CT 06062.

- Driscoll, D. D. 1979 (Dec). Retaining Wall Design Guide, Foundation Services, Inc., Portland, OR, Prepared for USDA Forest Service. Available from: USDA Forest Service Region 6, 319 S.W. Pine St., Portland, OR 97208.
- Duncan, J. M., and Buchignani, A. L. 1976 (Jun). "An Engineering Manual for Settlement Studies," Department of Civil Engineering, University of California, Berkeley.
- Elias, V. 1986. "Retaining Walls," Draft Bridge Design Manual, Part 4, Structures, Section 5, Pennsylvania Department of Transportation. Available from: V. Elias and Associates, 6809 Carlynn Court, Bethesda, MD 20817.
- Evergreen Systems, Inc. "Retaining Walls." Available from: Evergreen Systems, Inc., P. O. Box 345, Kings Point, NY 11754.
- Forsyth, R. A. 1979. "Alternate Earth Reinforcements," Proceedings, Symposium on Earth Reinforcement, American Society of Civil Engineers, pp 358-370. Available from: U. S. Army Engineer Waterways Experiment Station, P. O. Box 631, Vicksburg, MS 39180.
- Frondistou-Yannas, S. 1985 (Jan). "Corrosion Susceptibility of Internally Reinforced Soil Retaining Structures," Report No. FHWA-RD-83-105, U. S. Department of Transportation, Federal Highway Administration. Available from: Federal Highway Administration, Turner-Fairbank Highway Research Center, 6300 Georgetown Pike, McLean, VA 22101.
- Geotechnical Control Office. 1982 (Jun). Guide to Retaining Wall Design, Geoguide 1, Engineering Development Department, Hong Kong. Available from: U. S. Army Engineer Waterways Experiment Station, P. O. Box 631, Vicksburg, MS 39180.
- Godfrey, K. A., Jr. 1984 (Dec). "Retaining Walls: Competition or Anarchy?," Civil Engineering, Vol 54, No. 12, pp 48-52. Available from: U. S. Army Engineer Waterways Experiment Station, P. O. Box 631, Vicksburg, MS 39180.
- Harr, M. E. 1977. Mechanics of Particulate Media, McGraw-Hill, New York. Available from: McGraw-Hill International Book Company, 1221 Avenue of the Americas, New York, NY 10020.
- Harr, M. E. 1962. Groundwater and Seepage, McGraw-Hill, New York.
- Hilfiker Company. "R. S. E. Construction Guide." Available from: Hilfiker Company, 3900 Broadway, Eureka, CA 95501.
- Ingold, T. S. 1979a. "Retaining Wall Performance During Backfilling," Journal, Geotechnical Engineering Division, American Society of Civil Engineers, Vol 105, No. GT5, pp 613-626.

EM 1110-2-2502
29 Sep 89

- Ingold, T. S. 1979b. "The Effect of Compaction on Retaining Walls," Geotechnique, Vol 29, No. 3, pp 265-283.
- Ireland, H. O. 1964 (Aug). "Design and Construction of Retaining Walls," Design of Structures to Resist Earth Pressure, Soil Mechanics Lecture Series, Department of Civil Engineering, Illinois Institute of Technology, Chicago, IL. Available from: U. S. Army Engineer Waterways Experiment Station, P. O. Box 631, Vicksburg, MS 39180.
- Jackura, K. A. 1984 (May). "Results of Minor Research on Bar-Mat Pullout Tests," CA/TL-84-08, California Department of Transportation, Sacramento, CA.
- Jaky, J. 1944. "The Coefficient of Earth Pressure At-Rest," Journal, Society of Hungarian Architects and Engineers, Budapest, Hungary, pp 355-358.
- Jones, C. J. F. P. 1985. Earth Reinforcement and Soil Structures, Butterworths, London. Available from: U. S. Army Engineer Waterways Experiment Station, P. O. Box 631, Vicksburg, MS 39180.
- Kenney, T. C. 1959. Discussion of "Geotechnical Properties of Glacial Clays," by T. H. Wu, Journal of the Soil Mechanics and Foundations Division, ASCE, Vol 85, No. SM3, pp 67-79.
- Kraemer, S. R., and Smith, A. D. 1986 (Oct). "Geocomposite Drains," Vol I, Engineering Assessment and Preliminary Guidelines, Report No. FHWA-RD-86-171, U. S. Department of Transportation, Federal Highway Administration. Available from: Federal Highway Administration, 6300 Georgetown Pike, McLean, VA 22101.
- Leary, R. M., and Klinedinst, G. L. 1984 (May). "Retaining Wall Alternates," Proceedings, 34th Annual Highway Geology Symposium, Atlanta, GA. Available from: Federal Highway Administration, Geotechnical and Materials Branch, 400 7th St., S.W., Washington, DC 20590.
- Liu, Tony C., and Gleason, Scott. 1981 (Dec). "Strength Design of Reinforced Concrete Hydraulic Structures," Technical Report SL-80-4, U. S. Army Engineer Waterways Experiment Station, Vicksburg, MS. Available from: US Army Engineer Waterways Experiment Station, P. O. Box 631, Vicksburg, MS 39180.
- Long, N. T., et al. 1984 (May). "Repair of a Reinforced Earth Wall," Proceedings, International Conference on Case Histories in Geotechnical Engineering, Vol 1, pp 335-339, University of Missouri-Rolla, Rolla, MO. Available from: U. S. Army Engineer Waterways Experiment Station, P. O. Box 631, Vicksburg, MS 39180.
- Marcuson, W. F., and Bieganousky, W. A. 1977 (Nov). "SPT and Relative Density in Coarse Sands," Journal of the Geotechnical Engineering Division, ASCE, Vol 103, No. GT11, pp 1295-1309.

- Massarsch, K. R. 1979. "Lateral Earth Pressure in Normally Consolidated Clays," Proceedings of the Seventh European Conference on Soil Mechanics and Foundation Engineering, Brighton, England, Vol 2, pp 245-249.
- Matsuo, M., Kenmochi, S., Yagi, H. 1978 (Sep). "Experimental Study on Earth Pressure of Retaining Wall by Field Tests," Soils and Foundations, Japanese Society of Soil Mechanics and Foundation Engineering, Vol 18, No. 3, pp 27-41. Available from: Japanese Society of Soil Mechanics and Foundation Engineering, Suga-yama Building-4F, Kanda Awaji-cho 2-23 Chiyoda-ku, Tokyo 101, Japan.
- McGee, P. E. 1985 (Nov). "Reinforced Earth Wall Strip Serviceability Study," Special Research Study No. 8405, Geotechnical Engineering Bureau, Office of Materials and Research, Georgia Department of Transportation, Forest Park, GA. Available from: Engineering Design Unit, Georgia Department of Transportation, Office of Materials and Research, 15 Kennedy Drive, Forest Park, GA 30050.
- McGown, A., et al. 1985. "The Load-Strain-Time Behavior of Tensor Geogrids," Proceedings, Conference on Polymer Grid Reinforcement, pp 11-17, Thomas Telford Ltd., London. Available from: U. S. Army Engineer Waterways Experiment Station, P. O. Box 631, Vicksburg, MS 39180.
- McKittrick, D. 1979. "Design Construction, Technology, and Performance of Reinforced Earth Structures," Proceedings, Symposium on Earth Reinforcement, American Society of Civil Engineers, pp 596-616. Available from: U. S. Army Engineer Waterways Experiment Station, P. O. Box 631, Vicksburg, MS 39180.
- Meyerhof, G. G. 1956. "Penetration Tests and Bearing Capacity of Cohesionless Soils," Journal of the Soil Mechanics and Foundations Divisions, ASCE, Vol 82, No. SM1, pp 1-19.
- Mitchell, J. K., Villet, W. C. B., and DiMillio, A. F. 1984 (Dec). "Soil Reinforcement for Stabilization of Earth Slopes and Embankments," Public Roads, U. S. Department of Transportation, Vol 48, No. 3, pp 88-95. Available from: U. S. Army Engineer Waterways Experiment Station, P. O. Box 631, Vicksburg, MS 39180.
- Mitchell, J. K., and Villet, W. C. B., eds. 1986. "Reinforcement of Earth Slopes and Embankments," 4 Vols, National Cooperative Highway Research Program Project 24-2, National Research Council, Transportation Research Board, Washington, DC. Available from: National Cooperative Highway Research Program, 2101 Constitution Avenue, N.W., Washington, DC 20418.
- Mosher, Reed L., and Pace, Michael E. 1982 (Jun). User's Guide: Computer Program for Bearing Capacity Analyses of Shallow Foundations (CBEAR), Instruction Report K-82-7, U. S. Army Engineer Waterways Experiment Station, Vicksburg, MS. Available from: U. S. Army Engineer Waterways Experiment Station, P. O. Box 631, Vicksburg, MS 39180.

29 Sep 89

- Pace, Michael E, Noddin, Virginia R., 1987 (Oct). "Sliding Stability of Concrete Structures (CSLIDE)," Instruction Report ITL-87-5. Available from: U. S. Army Engineer Waterways Experiment Station, P. O. Box 631, Vicksburg, MS 39180.
- Pace, Michael E., Williams, Dennis R., Wolff, Thomas F., and Mosher, Reed. 1984 (Sep). "Seepage Analysis of Confined Flow Problems by the Method of Fragments (CFRAG)," Instruction Report K-84-8. Available from: U. S. Army Engineer Waterways Experiment Station, P. O. Box 631, Vicksburg, MS 39180.
- Peck, R. B., and Bazaraa, A. S. 1969. "Discussion on Settlement of Spread Footings on Sand," Journal of the Soil Mechanics and Foundations Division, ASCE, Vol 95, No. SM3, pp 905-909.
- Peck, R. B., Hanson, W. E., and Thornburn, T. H. 1974. Foundation Engineering, 2nd. ed., Wiley, New York.
- Robertson, P. K., and Campanella, R. G. 1983. "Interpretation of Cone Penetration Tests; Parts I and II," Canadian Geotechnical Journal, Vol 20, No. 4, pp 718-745.
- Schmertmann, J. H. 1975. "Measurement of In-Situ Strength," Proceedings of the Conference on In-Situ Measurement of Soil Properties, ASCE, pp 55-138.
- Schwab, G. O., et al. 1981. Soil and Water Conservation Engineering, John Wiley, New York, 3rd edition. Available from: U. S. Army Engineer Waterways Experiment Station, P. O. Box 631, Vicksburg, MS 39180.
- Seed, H. B. 1976 (Sep). "Evaluation of Soil Liquefaction Effects on Level Ground During Earthquakes," Liquefaction Problems in Geotechnical Engineering, ASCE annual convention and exposition, Philadelphia, PA, preprint 2752, pp 1-104.
- Seed, H. B., Arango, I., and Chan, C. K. 1975. "Evaluation of Soil Liquefaction Potential During Earthquakes," Report No. EERC 75-28, Earthquake Engineering Research Center, College of Engineering, University of California, Berkeley, CA.
- Seed, H. B., and Idriss, I. M. 1982. "Ground Motions and Soil Liquefaction During Earthquakes," Earthquake Engineering Research Institute, University of California, Berkeley, CA.
- Seed, H. B., and Whitman, R. V. 1970. "Design of Earth Retaining Structures for Dynamic Loads," ASCE Specialty Conference, Lateral Stresses in the Ground and Design of Earth Retaining Structures, pp 103-147.

- Shields, D. H., and Tolunay, A. Z. 1973. "Passive Pressure Coefficients by Method of Slices," Journal of the Soil Mechanics and Foundations Division, ASCE, Vol 99, No. SM12, pp 1043-1053.
- Sibley, E. A. 1967. "Backfill Adjacent to Structures," Proceedings of the Montana Conference on Soil Mechanics and Foundation Engineering, Department of Civil Engineering, Montana State University, Bozeman, MT. Available from: U. S. Army Engineer Waterways Experiment Station, P. O. Box 631, Vicksburg, MS 39180.
- Smith, A. D., and Kraemer, S. R. 1987 (Feb). "Creep of Geocomposite Drains," Proceedings, Geosynthetic '87 Conference, New Orleans, LA, Vol 2, pp 422-433. Available from: U. S. Army Engineer Waterways Experiment Station, P. O. Box 631, Vicksburg, MS 39180.
- Spangler, M. G., and Mickle, J. 1956. "Lateral Pressure on Retaining Walls Due to Backfill Surface Loads," Highway Research Board Bulletin 141, pp 1-18.
- Tcheng, Y., and Iseux, J. 1972. "Essais de Butee en Vraie Grandeur et Contraintes Engendrees par une Surcharge Rectangulaire sur un Mur Vertical," Proceedings, 5th European Conference on Soil Mechanics and Foundation Engineering, Madrid.
- Tensar Corp., "Tensar." 1984. Available from: The Tensar Corp., 1210 Citizens Parkway, Morrow, GA 30260.
- Terzaghi, K. 1934. "Large Retaining Wall Tests," Engineering News - Record, Vol 85, February 1--April 19.
- Terzaghi, K. 1943. Theoretical Soil Mechanics, John Wiley, New York.
- Terzaghi, K., and Peck, R. B. 1948. Soil Mechanics in Engineering Practice, John Wiley, New York. Available from: U. S. Army Engineer Waterways Experiment Station, P. O. Box 631, Vicksburg, MS 39180.
- Tracy, Fred T. 1977a (Aug). "An Interactive Graphics Finite Element Method Grid Generator for Two-Dimensional Problems," Miscellaneous Paper K-77-5, U. S. Army Engineer Waterways Experiment Station, Vicksburg, MS. Available from: U. S. Army Engineer Waterways Experiment Station, P. O. Box 631, Vicksburg, MS 39180.
- Tracy, Fred T. 1977b (Aug). "An Interactive Graphics Post-Processor for Finite Element Method Static Analyses," Miscellaneous Paper K-77-4, U. S. Army Engineer Waterways Experiment Station, Vicksburg, MS. Available from: U. S. Army Engineer Waterways Experiment Station, P. O. Box 631, Vicksburg, MS 39180.

EM 1110-2-2502
29 Sep 89

- Tracy, Fred T. 1983 (Sep). "User's Guide for a Plane and Axisymmetric Finite Element Program for Steady-State Seepage Problems," Instruction Report K-83-4, U. S. Army Engineer Waterways Experiment Station, Vicksburg, MS. Available from: U. S. Army Engineer Waterways Experiment Station, P. O. Box 631, Vicksburg, MS 39180.
- Tschebatarioff, G. 1949. "Large Scale Earth Pressure Tests with Model Flexible Bulkheads," Final Report to U. S. Navy, Bureau of Yards and Docks, Princeton University.
- U. S. Army Engineer Division, Ohio River. 1958 (Jun). "Final Report on Full-size Floodwall (T-type) Stability Test." Available from HQUSACE Library.
- U. S. Army Engineer Waterways Experiment Station. 1956 (Oct). "Investigation of Underseepage and Its Control," Technical Memorandum No. 3-424. Available from: U. S. Army Engineer Waterways Experiment Station, P. O. Box 631, Vicksburg, MS 39180.
- U. S. Army Engineer Waterways Experiment Station. 1960 (Apr). "The Unified Soil Classification System," Technical Memorandum No. 3-357. Available from: U. S. Army Engineer Waterways Experiment Station, P. O. Box 631, Vicksburg, MS 39180.
- U. S. Army Engineer Waterways Experiment Station. 1962 (Jun). Technical Report TR3-604. Engineering Properties of Fine-Grained Mississippi Valley Alluvial Soils Meander Belt and Blackswamp Deposits. Available from: U. S. Army Engineer Waterways Experiment Station, P. O. Box 631, Vicksburg, MS 39180.
- U. S. Army Engineer Waterways Experiment Station. 1980 (Aug). Rock Testing Handbook, Standard and Recommended Methods. Available from: U. S. Army Engineer Waterways Experiment Station, P. O. Box 631, Vicksburg, MS 39180.
- U. S. Army Engineer Waterways Experiment Station. 1984. Shore Protection Manual, Vol 2 of 2, Vicksburg, MS. Available from: Superintendent of Documents, U. S. Government Printing Office, Washington, DC 20402.
- Vesic, A. S. 1975. "Bearing Capacity of Shallow Foundations," Foundation Engineering Handbook, Hans F. Winterkorn and Hsai-Fang, ed., Van Nostrand Reinhold Co., New York.
- VSL Corporation. 1984. "Retaining Earth." Available from: VSL Corporation, 101 Albright Way, Los Gatos, CA 95030.
- Westergaard, H. M. 1933. "Water Pressures on Dams During Earthquakes," Transaction, American Society of Civil Engineers, Vol 98, pp 418-433. Available from: ASCE Publication Fulfillment, 345 East 4th St., New York, NY 10017.

Whitman, R. V., and Liao, S. 1985 (Jan). Seismic Design of Gravity Retaining Walls, Miscellaneous Paper GL-85-1, U. S. Army Engineer Waterways Experiment Station, Vicksburg, MS 39180.

Winterkorn, H. F., and Fang, H-Y., eds. 1975. Foundation Engineering Handbook, Van Nostrand-Reinhold, New York.

Wu, T. H. 1966. Soil Mechanics, Allyn and Bacon, Inc., Boston, MA.

APPENDIX B

BIBLIOGRAPHY

- Al-Yassin, Z. "Laboratory Pullout Test Results on VSL Retained Earth," November 1980. Available from: VSL Corporation, 101 Albright Way, Los Gatos, CA 95030.
- Bang, S. "Active Earth Pressure Behind Retaining Walls," Journal, Geotechnical Engineering, American Society of Civil Engineers, March 1985, Vol 111, No. 3.
- Bishop, J. A., and Anderson, L. A. "Performance of a Welded Wire Retaining Wall," Dec 1979, Report to Hilfiker Pipe Company, Department of Civil Engineering, University of Utah, Logan, UT. Available from: U. S. Army Engineer Waterways Experiment Station, P. O. Box 631, Vicksburg, MS 39180.
- Boyd, M. S. "Practical Application of Reinforced Earth Theory," Proceedings, Symposium on Soil Reinforcing and Stabilizing Techniques in Engineering Practice, Vol 1, Oct 1978, pp 83-110. Available from: U. S. Army Engineer Waterways Experiment Station, P. O. Box 631, Vicksburg, MS 39180.
- Dawkins, William P. User's Guide: Computer Program for Design and Analysis of Sheet Pile Walls by Classical Methods (CSHTWAL), U. S. Army Engineer Waterways Experiment Station, Vicksburg, MS, Instruction Report K-81-2, February 1981. Available from: U. S. Army Engineer Waterways Experiment Station, P. O. Box 631, Vicksburg, MS 39180.
- Department of the Army, Corps of Engineers. Expansion, Contraction, and Construction Joints in Concrete, Guide Specifications CW 03150. Available from: Corps of Engineers Publication Depot, 890 South Pickett St., Alexandria, VA 22304.
- Doublewal Corp. "Doublewal Interlocking Precast Retaining Wall System." Available from: Doublewal Corp., 59 East Main St., Plainville, CT 06062.
- Doublewal Corp. 1982. "Design Manual Doublewall Interlocking Reinforced Concrete Retaining Wall Systems." Available from: Doublewal Corp., 59 East Main St., Plainville, CT 06062.
- Egan, P. D. "Design and Performance of Reinforced Earth Bridge Abutments," Paper presented at First International Bridge Conference, Pittsburgh, PA, June 1984. Available from: Reinforced Earth Company, Rosslyn Center, 1700 North Moore St., Arlington, VA 22209.

EM 1110-2-2502

31 Mar 89

Goldberg-Zoino & Associates, Inc. "Report on Full Scale Field Test of Twenty-Two Foot High Doublewal," May 1983; Report to Doublewal Corporation, Newton Upper Falls, MA. Available from: Doublewal Corp., 59 East Main St., Plainville, CT 06062.

Hilfiker Company. 1984. "Reinforced Soil Embankment." Available from: Hilfiker Company, 3900 Broadway, Eureka, CA 95501.

International Society for Rock Mechanics, Commission on Standardization of Laboratory and Field Tests. "Suggested Methods for Determining Shear Strengths," Document No. 1, February 1974. Available from: Printing and Publishing Office, National Academy of Sciences--National Research Council, 2101 Constitution Ave., N.W., Washington, DC 20418.

McKittrick, D. P. "Reinforced Earth: Application of Theory and Research to Practice," Proceedings, Symposium on Soil Reinforcing and Stabilizing Techniques in Engineering Practice, Vol 2, October 1978, pp 1-44. Available from: U. S. Army Engineer Waterways Experiment Station, P. O. Box 631, Vicksburg, MS 39180.

Neilson, M. R. Pullout Resistance of Welded Wire Mats Embedded in Soil, 1984, M.S. Thesis, Department of Civil Engineering, University of Utah, Logan, UT. Available from: U. S. Army Engineer Waterways Experiment Station, P. O. Box 631, Vicksburg, MS 39180.

Netlon Limited. "Guidelines for the Design and Construction of Reinforced Soil Retaining Walls Using Tensar Geogrids," 1982. Available from: The Tensar Corp., 1210 Citizens Parkway, Morrow, GA 30260.

Netlon Limited. "Tensar Test Methods and Physical Properties of Tensar Geogrids," 1984. Available from: The Tensar Corp., 1210 Citizens Parkway, Morrow, GA 30260.

Peterson, L. M., and Anderson, L. R. "Pullout Resistance of Welded Wire Mesh Embedded in Soil," 1980, Department of Civil Engineering, University of Utah, Logan, UT. Available from: U. S. Army Engineer Waterways Experiment Station, P. O. Box 631, Vicksburg, MS 39180.

Price, William A., et al. User's Guide: Computer Program for Design and Analysis of Inverted-T Retaining Walls and Flood Walls (TWDA), Instruction Report K-80-6 and K-80-7, December 1980, U. S. Army Engineer Waterways Experiment Station, Vicksburg, MS. Available from: U. S. Army Engineer Waterways Experiment Station, P. O. Box 631, Vicksburg, MS. 39180.

Reinforced Earth Company. "Reinforced Earth Retaining Walls," Brochure 2.18b/RE, 1980. Available from: Reinforced Earth Company, Rosslyn Center, 1700 North Moore St., Arlington, VA 22209.

Selvage, Heber, Nelson and Associates, Inc. "Engineering Analysis of the Gridcote System," April 1984. Available from: Hilfiker Co., 3900 Broadway, Eureka, CA 95501.

VSL Corporation. "General Specification for Retaining Earth Walls," July 1984. Available from: VSL Corporation, 101 Albright Way, Los Gatos, CA 95030.

VSL Corporation. "Retained Earth, Field Erection Manual," March 1983. Available from: VSL Corporation, 101 Albright Way, Los Gatos, CA 95030.

VSL Corporation. "Retained Earth Walls, Design Procedure for Standard Walls," March 1984. Available from: VSL Corporation, 101 Albright Way, Los Gatos, CA 95030.

Welti, C. "Soil-Concrete Interaction Tests of 12' Wide Doublewal," October 1982, Glastonbury, CT. Available from: Doublewal Corporation, 59 East Main St., Plainville, CT 06062.

APPENDIX C

NOTATION

Chapters 3, 4, and 5

Symbol	Term
b	Distance over which base is in compression
B	Width of base of structure
\bar{B}	Effective width of base
c	Cohesion on slip plane of wedge
c_d	Developed cohesion on slip plane of wedge
c_1	Variable used to compute critical slip plane angle
c_2	Variable used to compute critical slip plane angle
C_E	Hydrodynamic factor
C_f	Coefficient used to compute wind loads
d_b	Depth of water at breaking wave occurrence
d_c	Depth of tension crack in cohesive backfill
d_s	Water depth
D	Depth of material in front of wall to base of structural wedge
e	Eccentricity of resultant at base of structural wedge
F	Inertia force of wall
FS	Factor of safety
F_T	Magnification factor
h	Wall height; height of fill against gravity wall or height of fill against "structural wedge"
H	Design wave height

29 Sep 89

Symbol	Term
H_b	Height of wave which breaks in water depth d_b
H_L	Horizontal force, acting to the right, applied to wedge
H_{Li}	Any horizontal force applied above the top or below the bottom of the left side adjacent wedge
H_R	Horizontal force, acting to the left, applied to wedge
H_{Ri}	Any horizontal force applied above the top or below the bottom of the right side adjacent wedge
H_s	Average of highest one-third of all waves or depth of saturation in wedge
H_1	Average of highest 1 percent of all waves
i	Number of wedge being analyzed
k_h	Horizontal acceleration in g's
k_v	Vertical acceleration in g's
K	Lateral earth pressure coefficient
K_A	Active earth pressure coefficient
K_{AE}	Mononobe-Okabe active earth pressure coefficient
K_i	Horizontal earth pressure coefficient for the i^{th} layer
K_o	At-rest earth pressure coefficient
$K_{o\beta}$	At-rest earth pressure coefficient calculated by Danish Code equation
K_p	Passive earth pressure coefficient
K_{PE}	Mononobe-Okabe passive earth pressure coefficient
L	Length along slip plane of wedge
L_i	Length along the slip plane of the i^{th} wedge
N'	Resultant of forces normal to the assumed sliding plane
N_c, N_q, N_r	Bearing capacity factors for strip load

Symbol	Term
p_E	Hydrodynamic pressure at depth y below top surface of water
p'_{hm}	Pressure due to compaction at depth z_{cr}
p'_{hz}	Effective horizontal pressure at depth z
p'_{vi}	Vertical effective earth pressure at the top of the i^{th} layer
p_{AH}	Horizontal active earth pressure at depth z
p_{PH}	Horizontal passive earth pressure at depth z
P	Lateral (horizontal) force produced by wedge
P_A	Total active force on a unit length of wall backfilled with a cohesionless material; static component for a driving wedge
P_{AE}	Static and dynamic forces due to driving wedge
P_{AH}	Horizontal component of active earth force
P_D	Absolute value of total horizontal force from driving wedges
P_E	Hydrodynamic force given by Westergaard's equation
P_{EE}	Effective horizontal earth force contributed by wedge or wedge segment
$(P_{i-1} - P_i)$	Summation of applied forces acting horizontally on i^{th} wedge
P_P	Static component for a resisting wedge
P_{PE}	Static and dynamic forces due to resisting wedge
P_{PH}	Horizontal component of passive earth force
P_R	Absolute value of total horizontal force from resisting wedges
P_W	Internal water force acting on the side of the wedge free body
P_{ws}	Static component of water force for partially saturated wedge
q'	Foundation pressure at base of structural wedge
q_o	Effective overburden pressure
Q	Vertical component of ultimate bearing capacity

Symbol	Term
SMF	Strength mobilization factor
T	Force tangential to slip plane of wedge
T	Earthquake period of vibration in seconds
T_F	Shear force that will cause failure along slip plane
U	Uplift force normal to slip plane of wedge
U_i	Uplift force exerted normal to slip plane of the i^{th} angle
V	Vertical force applied to wedge
V_i	Any vertical force applied above the top of the i^{th} wedge
ΣV	Summation of vertical forces for structural wedge
V_{max}	Maximum value of V for which the equations for c_1 and c_2 are valid
W	Total weight of material in wedge
W_i	Total weight of water, soil, rock, or concrete in the i^{th} wedge
x_R	Location of resultant force from toe of structure
Y_{AE}	Line of action of P_{AE}
Y_{PE}	Line of action of P_{PE}
z	Depth from the top of the wall
z_i	Vertical distance measured down from the top of the i^{th} layer
z_{cr}	Critical depth where pressure due to compaction equals p'_{hm}
z_w	Depth to water table
α	Angle between slip plane of wedge and horizontal
α_i	Angle between slip plane of the i^{th} wedge and the horizontal
β	Angle between top of wedge and horizontal
γ	Unit weight of material
δ	Angle of wall friction

Symbol	Term
γ'	Effective unit weight of material
γ_i	Effective unit weight of the i^{th} layer
θ	Angle of the wall face from horizontal or inclination of wall with respect to vertical
ϕ	Angle of internal friction on slip plane of wedge
ϕ'	Drained friction angle
ϕ_d	Developed angle of internal friction on slip plane of wedge
σ	Stress normal to slip plane
σ'_n	Effective normal stress
τ	Applied shear stress on slip plane of wedge
τ_f	Shear strength of wedge material
ψ	Seismic inertia angle
$\gamma_{\text{sat}}, \gamma_s$	Saturated unit weight of fill
γ_w	Unit weight of water
γ_b	Buoyant unit weight of fill
$\tan \phi$	Unfactored shear strength parameter of the foundation material through which sliding plane passes
$\tan \phi_d$	Portion of shear strength considered to be mobilized or developed along the slip plane(s)
$\tan c$	Unfactored shear strength parameter of the foundation material through which sliding plane passes
ξ	Correction factors for bearing capacity
Δp_{HX}	Increase in horizontal pressure at distance x due to surcharge
Δp_{HZ}	Increase in horizontal pressure at depth z due to surcharge
ΔP_{H}	Increase in horizontal force due to surcharge
ΔP_{AE}	Dynamic component of total driving force
ΔP_{PE}	Dynamic component of total resisting force

APPENDIX D

NOTATION

Chapter 9

<u>Symbol</u>	<u>Term</u>
a	Depth of equivalent rectangular stress block
A_g	Gross area of section, sq. in.
A_s	Area of tension reinforcement, sq. in.
A'_s	Area of compression reinforcement, sq. in.
b	Width of compression face of member, in.
c	Distance from extreme compression fiber to neutral axis, in.
d	Distance from extreme compression fiber to centroid of tension reinforcement, in.
d'	Distance from extreme compression fiber to centroid of compression reinforcement, in.
D	Dead load of the concrete members only or related internal forces and moments
e'	Eccentricity of axial load measured from the centroid of the tension reinforcement = $d - h/2$
E_s	Modulus of elasticity of reinforcement, psi
f'_c	Specified compressive strength of concrete, psi
f_s	Calculated stress at centroid of tension reinforcement when compression controls
f'_s	Calculated stress at centroid of compression reinforcement
f_y	Specified yield strength of reinforcement, psi
h	Total depth of section, in.
k_m	Ratio of stress block depth (a) to the effective depth (d), at balanced strain conditions for hydraulic structures
k_u	Ratio of stress block depth (a) to the effective depth (d)

Symbol	Term
L	Live loads or related internal moments and forces
M_u	Internal moment due to factored axial load, P_u
P_b	Axial load at given eccentricity at the balanced strain condition
P_n	Nominal axial load strength at given eccentricity
P_u	Factored axial load at given eccentricity
U	Required strength to resist factored loads or related internal moments and forces
V_c	Shear strength
W	Wind load or related internal moments and forces
β_m	A coefficient which accounts for the difference between the distribution of actual compression stresses and the assumed rectangular distribution of stresses
β_1	Defined the same as β_m but the value is in accordance with ACI 318
ϵ_c	Maximum usable strain at extreme concrete compression fiber = 0.003
ϵ_m	Design strain at the extreme concrete compression fiber = $0.5 \epsilon_c$
ϵ_y	Strain at the centroid of the tension reinforcements $\leq f_y/E_s$
ϕ	Strength reduction factor
ρ	Ratio of tension reinforcement, A_s/bd
ρ_b	Reinforcement ratio producing balanced strain conditions
ρ_m	Reinforcement ratio corresponding to balanced strain conditions for hydraulic structures
λ	Maximum percentage of ρ_b allowed for hydraulic structures

APPENDIX E

COMPARISON OF DANISH CODE AND JAKY EQUATIONS FOR AT-REST
COEFFICIENT WITH COULOMB COEFFICIENT FOUND USING
REDUCED SHEAR STRENGTH PARAMETER ϕ_d

$$\phi_d = \tan^{-1} \left(\frac{2}{3} \tan \phi \right)$$

Jaky, Equation 3-4

Danish Code, Equation 3-6

Coulomb, Equation 3-14

Table E-1

At-Rest Earth Pressure Coefficients for Comparison of Coulomb's Equation with an SMF of 2/3
to the Danish Code and Jaky Equations

ϕ (deg)	ϕ (rad)	Inclined Backfill											
		Horizontal Backfill				$\beta = -10^\circ$		$\beta = 0^\circ$		$\beta = 10^\circ$		$\beta = 20^\circ$	
		K_o (Jaky)	K_o (SMF = 2/3)	K_{oB} (Danish)	K_o (SMF = 2/3)	K_{oB} (Danish)	K_o (SMF = 2/3)	K_{oB} (Danish)	K_o (SMF = 2/3)	K_{oB} (Danish)	K_o (SMF = 2/3)	K_{oB} (Danish)	K_o (SMF = 2/3)
10	0.175	0.826	0.791	0.683	0.703	0.826	0.791	0.970					
11	0.192	0.809	0.772	0.669	0.686	0.809	0.772	0.950					
12	0.209	0.792	0.754	0.655	0.669	0.792	0.754	0.930					
13	0.227	0.775	0.736	0.640	0.653	0.775	0.736	0.910					
14	0.244	0.758	0.718	0.626	0.638	0.758	0.718	0.890					
15	0.262	0.741	0.701	0.612	0.622	0.741	0.701	0.870	0.931				
16	0.279	0.724	0.684	0.599	0.607	0.724	0.684	0.850	0.871				
17	0.297	0.708	0.667	0.585	0.593	0.708	0.667	0.831	0.833				
18	0.314	0.691	0.651	0.571	0.578	0.691	0.651	0.811	0.802				
19	0.332	0.674	0.634	0.557	0.564	0.674	0.634	0.792	0.774				
20	0.349	0.658	0.618	0.544	0.550	0.658	0.618	0.772	0.748	0.883			
21	0.367	0.642	0.603	0.530	0.537	0.642	0.603	0.753	0.724	0.861			
22	0.384	0.625	0.587	0.517	0.523	0.625	0.587	0.734	0.702	0.839			
23	0.401	0.609	0.572	0.503	0.510	0.609	0.572	0.715	0.680	0.818			
24	0.419	0.593	0.557	0.490	0.497	0.593	0.557	0.696	0.659	0.796			
25	0.436	0.577	0.542	0.477	0.485	0.577	0.542	0.678	0.638	0.775			
26	0.454	0.562	0.528	0.464	0.472	0.562	0.528	0.659	0.619	0.754			
27	0.471	0.546	0.513	0.451	0.460	0.546	0.513	0.641	0.599	0.733			
28	0.489	0.531	0.499	0.438	0.448	0.531	0.499	0.623	0.581	0.712			
29	0.506	0.515	0.485	0.426	0.436	0.515	0.485	0.605	0.563	0.691	0.809		
30	0.524	0.500	0.471	0.413	0.424	0.500	0.471	0.587	0.545	0.671	0.742		
31	0.541	0.485	0.458	0.401	0.412	0.485	0.458	0.569	0.527	0.651	0.696		
32	0.559	0.470	0.445	0.388	0.400	0.470	0.445	0.552	0.510	0.611	0.660		
33	0.576	0.455	0.431	0.376	0.389	0.455	0.431	0.534	0.494	0.611	0.627		
34	0.593	0.441	0.418	0.364	0.378	0.441	0.418	0.517	0.478	0.592	0.598		
35	0.611	0.426	0.405	0.352	0.367	0.426	0.405	0.500	0.462	0.572	0.572		
36	0.628	0.412	0.393	0.341	0.356	0.412	0.393	0.484	0.446	0.553	0.547		
37	0.646	0.398	0.380	0.329	0.345	0.398	0.380	0.467	0.431	0.534	0.523		
38	0.663	0.384	0.368	0.318	0.334	0.384	0.368	0.451	0.416	0.516	0.501		
39	0.681	0.371	0.356	0.306	0.323	0.371	0.356	0.435	0.401	0.497	0.479		
40	0.698	0.357	0.344	0.295	0.313	0.357	0.344	0.419	0.386	0.479	0.459		
41	0.716	0.344	0.332	0.284	0.303	0.344	0.332	0.404	0.372	0.462	0.439		
42	0.733	0.331	0.320	0.273	0.292	0.331	0.320	0.388	0.358	0.444	0.420		
43	0.750	0.318	0.309	0.263	0.282	0.318	0.309	0.373	0.345	0.427	0.402		
44	0.768	0.305	0.298	0.252	0.272	0.305	0.298	0.358	0.331	0.410	0.384		
45	0.785	0.293	0.286	0.242	0.263	0.293	0.286	0.344	0.318	0.393	0.367		

Note: A blank entry in the table denotes where $\beta > \phi_d$.

APPENDIX F

DERIVATION OF GENERAL WEDGE EQUATION FOR SINGLE
WEDGE ANALYSIS (EQUATION 3-23)

F-1. Effective horizontal earth force. Given the following driving wedge, an equation for P_{EE} , the effective horizontal earth force, will be derived.

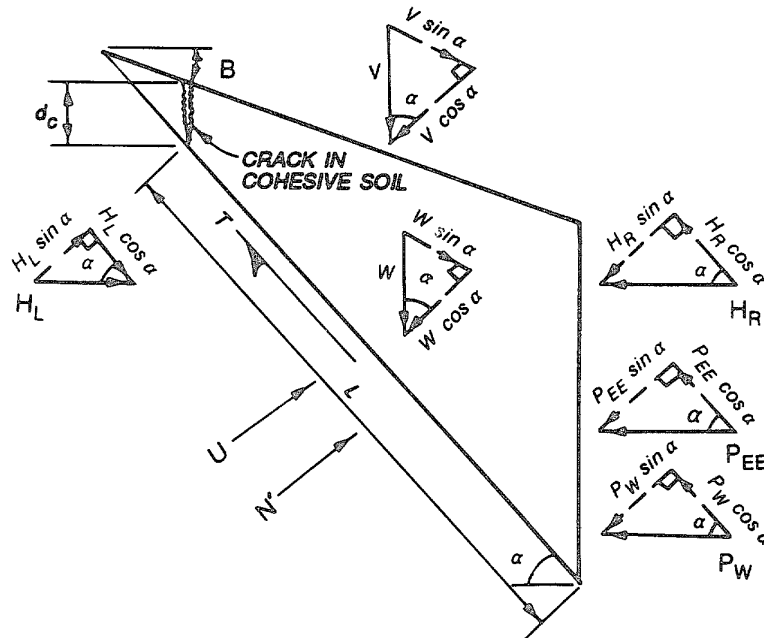

Summing forces normal to the slip plane yields,

$$H_L \sin \alpha + U + N' - V \cos \alpha - H_R \sin \alpha - P_{EE} \sin \alpha - P_W \sin \alpha - W \cos \alpha = 0$$

Solving for N' yields,

$$N' = (-H_L + H_R + P_{EE} + P_W) \sin \alpha - U + (V + W) \cos \alpha \quad [F-1]$$

According to the Mohr-Coulomb failure criterion,

$$T = N' \tan \phi + cL \quad [F-2]$$

Inserting Equation F-1 into Equation F-2 yields,

29 Sep 89

$$T = [(-H_L + H_R + P_{FR} + P_W) \sin \alpha - U + (V + W) \cos \alpha] \tan \phi + cL$$

Setting the summation of forces parallel to the slip plane equal to zero yields

$$H_L \cos \alpha + V \sin \alpha + W \sin \alpha - H_R \cos \alpha - P_{EE} \cos \alpha - P_W \cos \alpha - T = 0 \quad [F-3]$$

Solving for T from Equation F-3 and substituting this expression into Equation F-2 yields,

$$(H_L - H_R - P_{EE} - P_W) \cos \alpha + (V + W) \sin \alpha + \left[(H_L - H_R - P_{EE} - P_W) \sin \alpha + U - (V + W) \cos \alpha \right] \tan \phi - cL = 0$$

Simplifying and solving for P_{EE} yields,

$$P_{EE} = (V + W) \frac{(\sin \alpha - \cos \alpha \tan \phi)}{(\cos \alpha + \sin \alpha \tan \phi)} + \frac{U \tan \phi - cL}{\cos \alpha + \sin \alpha \tan \phi} + H_L - H_R - P_W$$

$$P_{EE} = (V + W) \frac{(1 - \cot \alpha \tan \phi) \tan \alpha}{(1 + \tan \alpha \tan \phi)} + \frac{U \tan \phi - cL}{(1 + \tan \alpha \tan \phi) \cos \alpha}$$

$$+ H_L - H_R - P_W \quad [F-4]$$

F-2. Soil parameters. For a particular SMF, the corresponding factored parameters ϕ_d and c_d can be inserted into Equation F-4 to yield soil

$$P_{EE} = (V + W) \frac{(1 - \cot \alpha \tan \phi_d) \tan \alpha}{(1 + \tan \alpha \tan \phi_d)} + \frac{U \tan \phi_d - c_d L}{(1 + \tan \alpha \tan \phi_d) \cos \alpha}$$

$$+ H_L - H_R - P_W$$

F-3. Resisting wedge. The same procedure can be applied to a resisting wedge to yield the following equation for P_{EE} .

$$P_{EE} = (W + V) \frac{(1 + \tan \phi_d \cot \alpha) \tan \alpha}{(1 - \tan \phi_d \tan \alpha)} - \frac{U \tan \phi_d - c_d L}{\cos \alpha (1 - \tan \phi_d \tan \alpha)}$$

- H_L + H_R - P_W

If more than one driving or resisting wedge exists, the value of P_{EE} will equal the difference of the earth forces applied to the wedge.

APPENDIX G

DERIVATION OF EQUATIONS FOR CRITICAL SLIP-PLANE
ANGLE (α) FOR DRIVING AND RESISTING WEDGES

G-1. Derivation of Critical Slip-Plane Angle (α) for Driving Wedges for the Static Condition. In the following paragraphs the equations for the critical slip-plane angle (α) will be derived for the static case for a driving wedge.

a. Introduction. The wedge equation (Equation 3-23) with the uplift term omitted is:

$$P_{EE} = \frac{(W + V)(1 - \tan \phi \cot \alpha) \tan \alpha}{1 + \tan \phi \tan \alpha} - \frac{cL}{\cos \alpha (1 + \tan \phi \tan \alpha)} \quad [G-1]$$

where

$$L = \text{length of slip plane} = \frac{h - d_c}{\cos \alpha (\tan \alpha - \tan \beta)}$$

$$W = \frac{\gamma(h^2 - d_c^2)}{2 (\tan \alpha - \tan \beta)}$$

as shown in the figure below.

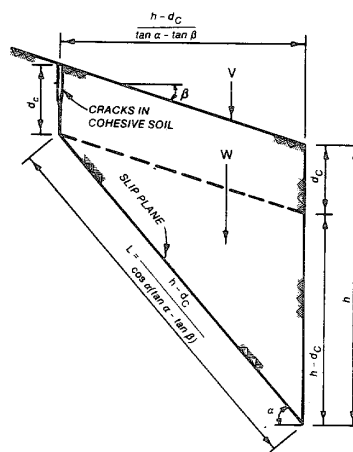

W = WEIGHT OF SOIL IN WEDGE.
V = ANY SURFACE LOAD OTHER THAN
A UNIFORM SURCHARGE

Inserting the terms for L and W into Equation G-1 yields,

$$P_{EE} = \frac{\gamma(h^2 - d_c^2)}{2(\tan \alpha - \tan \beta)} \cdot \frac{(1 - \tan \phi \cot \alpha) \tan \alpha}{1 + \tan \phi \tan \alpha} + \frac{V(1 - \tan \phi \cot \alpha) \tan \alpha}{1 + \tan \phi \tan \alpha} \cdot \frac{c(h - d_c)}{\cos^2 \alpha (\tan \alpha - \tan \beta)(1 + \tan \phi \tan \alpha)}$$

Using the trigonometric identity $\frac{1}{\cos^2 \alpha} = \sec^2 \alpha = 1 + \tan^2 \alpha$ and putting all terms over a common denominator

$$P_{EE} = \left[\gamma(h^2 - d_c^2)(\tan \alpha - \tan \phi) + 2V(\tan \alpha - \tan \phi)(\tan \alpha - \tan \beta) - 2c(h - d_c)(1 + \tan^2 \alpha) \right] \div \left[2(\tan \alpha - \tan \beta)(1 + \tan \phi \tan \alpha) \right] \quad [G-2]$$

The first derivative of P_{EE} with respect to α may now be taken, and set equal to zero. The resulting expression is solved for the critical value of $\tan \alpha$. For simplification, the calculus is done in parts.

b. First Derivative of γ Term. Grouping the terms from Equation G-2 that are associated with γ yields,

$$P_{EE\gamma} = \frac{\gamma(h^2 - d_c^2)}{2} \cdot \frac{\tan \alpha - \tan \phi}{(\tan \alpha - \tan \beta)(1 + \tan \phi \tan \alpha)}$$

$$P_{EE\gamma} = \frac{\gamma(h^2 - d_c^2)}{2} \cdot \frac{\tan \alpha - \tan \phi}{\tan \phi \tan^2 \alpha + (1 - \tan \phi \tan \beta) \tan \alpha - \tan \beta} = \frac{m\gamma}{n} \quad [G-3]$$

The first derivative of Equation G-3 is

$$\frac{dP}{d\alpha} = \frac{\frac{ndm}{d\alpha} \gamma - \frac{m}{d\alpha} \frac{dn}{d\alpha}}{n^2}$$

The denominator may be neglected because it is the same for all terms in Equation G-2.

$$\frac{dm}{d\alpha} \gamma = a \sec^2 \alpha, \text{ let } \frac{\gamma(h^2 - d_c^2)}{2} = a$$

$$\frac{dn}{d\alpha} = [2 \tan \phi \tan \alpha + (1 - \tan \phi \tan \beta)] \sec^2 \alpha$$

$$\frac{ndm}{d\alpha} \gamma = a [\tan \phi \tan^2 \alpha + (1 - \tan \phi \tan \beta) \tan \alpha - \tan \beta] \sec^2 \alpha$$

$$\begin{aligned} \frac{m}{d\alpha} \frac{dn}{d\alpha} = a [& 2 \tan \phi \tan^2 \alpha - (2 \tan^2 \phi + 1 - \tan \phi \tan \beta) \tan \alpha \\ & + \tan^2 \phi \tan \beta - \tan \phi (1 - \tan \phi \tan \beta)] \sec^2 \alpha \end{aligned}$$

$$\begin{aligned} \frac{ndm}{d\alpha} \gamma - \frac{m}{d\alpha} \frac{dn}{d\alpha} = \frac{\gamma(h^2 - d_c^2)}{2} [& -\tan \phi \tan^2 \alpha + 2 \tan^2 \phi \tan \alpha \\ & + \tan \phi (1 - \tan \phi \tan \beta) - \tan \beta] \sec^2 \alpha \end{aligned} \quad [G-4]$$

c. First Derivative of c Term. Grouping the terms from Equation G-2 that are associated with c yields,

$$P_{EEc} = -c(h - d_c) \cdot \frac{1 + \tan^2 \alpha}{\tan \phi \tan^2 \alpha + (1 - \tan \phi \tan \beta) \tan \alpha - \tan \beta} = \frac{m_c}{n}$$

$$\text{Let } \frac{-c(h - d_c)}{c} = a$$

29 Sep 89

$$\frac{dm_c}{d\alpha} = a(2 \tan \alpha) \sec^2 \alpha$$

$$\frac{dn}{d\alpha} = [2 \tan \phi \tan \alpha + (1 - \tan \phi \tan \beta)] \sec^2 \alpha$$

$$\frac{ndm_c}{d\alpha} = a \left[2 \tan \phi \tan^3 \alpha + 2(1 - \tan \phi \tan \beta) \tan^2 \alpha - 2 \tan \beta \tan \alpha \right] \sec^2 \alpha$$

$$\frac{m_c dn}{d\alpha} = a \left[2 \tan \phi \tan^3 \alpha + (1 - \tan \phi \tan \beta) \tan^2 \alpha + 2 \tan \phi \tan \alpha + (1 - \tan \phi \tan \beta) \right] \sec^2 \alpha$$

$$\frac{ndm_c}{d\alpha} - \frac{m_c dn}{d\alpha} = -c(h - d_c) \left[(1 - \tan \phi \tan \beta) \tan^2 \alpha - 2 (\tan \phi + \tan \beta) \tan \alpha - (1 - \tan \phi \tan \beta) \right] \sec^2 \alpha \quad [G-5]$$

d. First Derivative of V Term. Grouping the terms from Equation G-2 that are associated with the V term yields,

$$P_{EEV} = \frac{V [\tan^2 \alpha - (\tan \phi + \tan \beta) \tan \alpha + \tan \phi \tan \beta]}{\tan \phi \tan^2 \alpha + (1 - \tan \phi \tan \beta) \tan \alpha - \tan \beta} = \frac{m_v}{n}$$

$$\frac{dm_v}{d\alpha} = V [2 \tan \alpha - (\tan \phi \tan \beta)] \sec^2 \alpha$$

$$\frac{dn}{d\alpha} = [2 \tan \phi \tan \alpha + (1 - \tan \phi \tan \beta)] \sec^2 \alpha$$

$$\begin{aligned} \frac{ndm_v}{d\alpha} = V & \left\{ \left[2 \tan \phi \tan^3 \alpha + (2 - 3 \tan \phi \tan \beta - \tan^2 \phi) \right] \tan^2 \alpha \right. \\ & - \left[3 \tan \beta + \tan \phi - \tan \phi \tan \beta (\tan \phi + \tan \beta) \right] \tan \alpha \\ & \left. + \tan \beta (\tan \phi + \tan \beta) \right\} \sec^2 \alpha \end{aligned}$$

$$\begin{aligned} \frac{m_v dn}{d\alpha} = V & \left\{ \left[2 \tan \phi \tan^3 \alpha + (1 - 3 \tan \phi \tan \beta - 2 \tan^2 \phi) \right] \tan^2 \alpha \right. \\ & + \left[2 \tan^2 \phi \tan \beta - (1 - \tan \phi \tan \beta) \right] \tan \alpha \\ & \left. + \tan \phi \tan \beta (1 - \tan \phi \tan \beta) \right\} \sec^2 \alpha \end{aligned}$$

$$\begin{aligned} \frac{ndm_v}{d\alpha} - \frac{m_v dn}{d\alpha} = V & \left[(1 + \tan^2 \phi) \tan^2 \alpha - 2 \tan \beta (1 + \tan^2 \phi) \tan \alpha \right. \\ & \left. + \tan^2 \beta (1 + \tan^2 \phi) \right] \sec^2 \alpha \end{aligned} \quad [G-6]$$

e. Summation of Terms. From Equations G-4, G-5, and G-6, set the sum of

$$\left(\frac{ndm_v}{d\alpha} - \frac{m_v dn}{d\alpha} \right) + \left(\frac{ndm_c}{d\alpha} - \frac{m_c dn}{d\alpha} \right) + \left(\frac{ndm_v}{d\alpha} - \frac{m_v dn}{d\alpha} \right) \quad \text{equal to zero, and divide by}$$

$$\sec^2 \alpha .$$

29 Sep 89

$$\begin{aligned}
& \left[-\frac{\gamma(h^2 - d_c^2) \tan \phi}{2} - c(h - d_c)(1 - \tan \phi \tan \beta) + V(1 + \tan^2 \phi) \right] \tan^2 \alpha \\
& + \left[\frac{\gamma(h^2 - d_c^2)(2 \tan^2 \phi)}{2} + 2c(h - d_c)(\tan \phi + \tan \beta) \right. \\
& \left. - 2V \tan \beta(1 + \tan^2 \phi) \right] \tan \alpha \\
& + \left\{ \frac{\gamma(h^2 - d_c^2)}{2} [\tan \phi(1 - \tan \phi \tan \beta) - \tan \beta] \right. \\
& \left. + c(h - d_c)(1 - \tan \phi \tan \beta) + V \tan^2 \beta(1 + \tan^2 \phi) \right\} = 0
\end{aligned}$$

Divide all terms by $-\frac{\gamma(h^2 - d_c^2)}{2}$.

$$\begin{aligned}
& \left[\tan \phi + \frac{2c(1 - \tan \phi \tan \beta)}{\gamma(h + d_c)} - \frac{2V(1 + \tan^2 \phi)}{\gamma(h^2 - d_c^2)} \right] \tan^2 \alpha \\
& - \left[2 \tan^2 \phi + \frac{4c(\tan \phi + \tan \beta)}{\gamma(h + d_c)} - \frac{4V \tan \beta(1 + \tan^2 \phi)}{\gamma(h^2 - d_c^2)} \right] \tan \alpha \\
& - \left[\tan \phi(1 - \tan \phi \tan \beta) - \tan \beta + \frac{2c(1 - \tan \phi \tan \beta)}{\gamma(h + d_c)} \right. \\
& \left. + \frac{2V \tan^2 \beta(1 + \tan^2 \phi)}{\gamma(h^2 - d_c^2)} \right] = 0 \quad [G-7]
\end{aligned}$$

In Equation G-7, let the coefficient of $\tan^2 \alpha$ equal A , let the coefficient of $\tan \alpha$ equal $-Ac_1$, and let the third coefficient equal $-Ac_2$. Equation G-7 yields

$$A \tan^2 \alpha - A c_1 \tan \alpha - A c_2 = 0$$

$$\tan^2 \alpha - c_1 \tan \alpha - c_2 = 0$$

and

$$\tan \alpha_{\text{crit.}} = \frac{c_1 + \sqrt{c_1^2 + 4c_2}}{2}$$

or

$$\alpha_{\text{crit.}} = \tan^{-1} \left(\frac{c_1 + \sqrt{c_1^2 + 4c_2}}{2} \right) \quad [\text{G-8}]$$

The coefficients c_1 and c_2 are defined as

$$c_1 = \frac{2 \tan^2 \phi + \frac{4c (\tan \phi + \tan \beta)}{\gamma(h + d_c)} - \frac{4V \tan \beta (1 + \tan^2 \phi)}{\gamma(h^2 - d_c^2)}}{A} \quad [\text{G-9}]$$

$$c_2 = \frac{\tan \phi (1 - \tan \phi \tan \beta) - \tan \beta + \frac{2c(1 - \tan \phi \tan \beta)}{\gamma(h + d_c)} + \frac{2V \tan^2 \beta (1 + \tan^2 \phi)}{\gamma(h^2 - d_c^2)}}{A} \quad [\text{G-10}]$$

where

$$A = \tan \phi + \frac{2c(1 - \tan \phi \tan \beta)}{\gamma(h + d_c)} - \frac{2V(1 + \tan^2 \phi)}{\gamma(h^2 - d_c^2)} \quad [\text{G-11}]$$

G-2. Derivation of Equation for V_{\max} . The equations for calculating the critical value of α are not valid when the value of V is too large. When V is equal to or greater than a certain maximum value (V_{\max}) the value of α should be set in accordance with Figure 3-15. The value of V_{\max} is found by setting Equation 3-28 equal to zero and solving.

$$\tan \phi + \frac{2c(1 - \tan \phi \tan \beta)}{\gamma(H + d_c)} - \frac{2V_{\max}(1 + \tan^2 \phi)}{\gamma(h^2 - d_c^2)} = 0$$

$$\frac{2V_{\max}(1 + \tan^2 \phi)}{\gamma(h^2 - d_c^2)} = \frac{\gamma(h + d_c) \tan \phi + 2c(1 - \tan \phi \tan \beta)}{\gamma(h - d_c)}$$

$$V_{\max} = \frac{\gamma(h^2 - d_c^2) \tan \phi + 2c(h - d_c)(1 - \tan \phi \tan \beta)}{2(1 + \tan^2 \phi)} \quad [G-12]$$

G-3. Equations for Critical Slip-Plane Angles for Resisting Wedges for the Static Condition. The following equations, for resisting wedges, were derived from Equation 3-33 in the same manner used for deriving the driving wedge equations for the static condition.

$$A = \tan \phi + \frac{2c(1 + \tan \phi \tan \beta)}{\gamma h} + \frac{2V(1 + \tan^2 \phi)}{\gamma h^2} \quad [G-13]$$

$$c_1 = \frac{2 \tan^2 \phi + \frac{4c(\tan \phi - \tan \beta)}{\gamma h} - \frac{4V \tan \beta(1 + \tan^2 \phi)}{\gamma h^2}}{A} \quad [G-14]$$

$$c_2 = \frac{\tan \phi(1 + \tan \phi \tan \beta) + \tan \beta + \frac{2c(1 + \tan \phi \tan \beta)}{\gamma h} - \frac{2V \tan^2 \beta(1 + \tan^2 \phi)}{\gamma h^2}}{A} \quad [G-15]$$

$$\alpha = \tan^{-1} \left(\frac{-c_1 + \sqrt{c_1^2 + 4c_2}}{2} \right) \quad [G-16]$$

Note: $d_c = 0$, in cohesive soil on resisting side of walls.

G-4. Effect of Water on Critical Slip-Plane Angle. The unit weight of soil (γ) to use in equations for calculating the slip-plane angle should be the average unit weight of soil in the wedge. The average unit weight is determined by using the moist unit weight of soil above the water table and the buoyant unit weight below the water table. The effect of seepage should be taken into account in determining the buoyant unit weight. See Appendices M and N for example calculations.

G-5. Derivation of Equations for Critical Slip-Plane Angle (α) for Driving Wedges for Earthquake Condition. The equations for the critical slip-plane angle (α) for a driving wedge as shown in the figure below for the dynamic case will be derived.

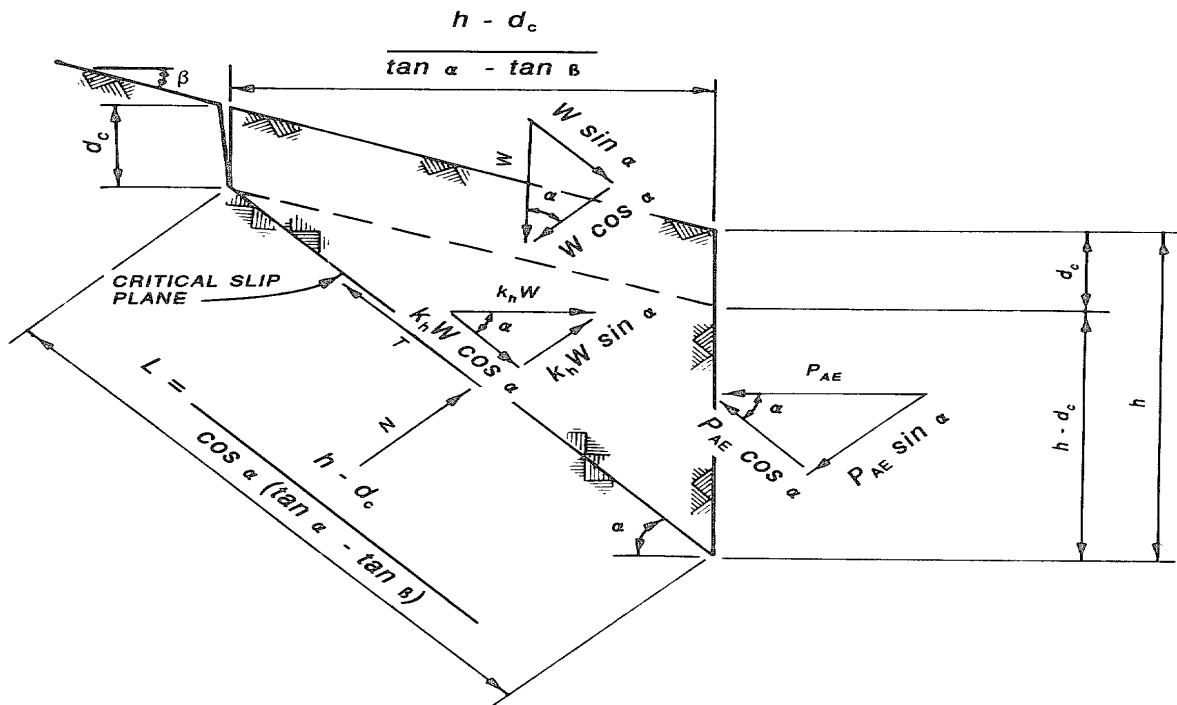

a. Summation of Forces. Summing forces normal to the sliding plane yields

29 Sep 89

$$N = W \cos \alpha + P_{AE} \sin \alpha - k_h W \sin \alpha$$

The shearing force T is defined by the Mohr-Coulomb failure criterion as

$$T = N \tan \phi + cL = (W \cos \alpha + P_{AE} \sin \alpha - k_h W \sin \alpha) \tan \phi + cL$$

Summing forces parallel to slip plane and inserting the expression for T yields

$$P_{AE} \cos \alpha - k_h W \cos \alpha - W \sin \alpha + (W \cos \alpha + P_{AE} \sin \alpha - k_h W \sin \alpha) \tan \phi + cL = 0$$

$$P_{AE} (\cos \alpha + \tan \phi \sin \alpha) = W (\sin \alpha - \tan \phi \cos \alpha) + k_h W (\cos \alpha + \tan \phi \sin \alpha) - cL$$

Solving for P_{AE} yields

$$P_{AE} = \frac{W[(1 + k_h \tan \phi) \sin \alpha - (\tan \phi - k_h) \cos \alpha] - cL}{\cos \alpha + \tan \phi \sin \alpha}$$

Referring to the figure,

$$W = \frac{\gamma(h^2 - d_c^2)}{2(\tan \alpha - \tan \beta)}, \quad L = \frac{h - d_c}{\cos \alpha (\tan \alpha - \tan \beta)}$$

Inserting the terms for W and L into the equation for P_{AE} yields

$$P_{AE} = \frac{\gamma(h^2 - d_c^2) [(1 + k_h \tan \phi) \sin \alpha - (\tan \alpha - k_h) \cos \alpha]}{2(\tan \alpha - \tan \beta) (\cos \alpha + \tan \phi \sin \alpha)} - \frac{c(h - d_c)}{\cos \alpha (\tan \alpha - \tan \beta) (\cos \alpha + \tan \phi \sin \alpha)}$$

Using the trigonometric relationship $\sec^2 \alpha = \frac{1}{\cos^2 \alpha}$

$$P_{AE} = \frac{\gamma(h^2 - d_c^2) [(1 + k_h \tan \phi) \tan \alpha - (\tan \phi - k_h)]}{2(\tan \alpha - \tan \beta)(1 + \tan \phi \tan \alpha)}$$

$$- \frac{2c(h - dc) \sec^2 \alpha}{2(\tan \alpha - \tan \beta)(1 + \tan \phi \tan \alpha)}$$

Now using the trigonometric relationship $\sec^2 \alpha = 1 + \tan^2 \alpha$ and rearranging

$$\frac{2P_{AE}}{\gamma(h^2 - d_c^2)} = \frac{(1 + k_h \tan \phi) \tan \alpha - (\tan \phi - k_h) - \frac{2c}{h + d_c} (1 + \tan^2 \alpha)}{\tan \phi \tan^2 \alpha + (1 - \tan \phi \tan \beta) \tan \alpha - \tan \beta} = \frac{m}{n}$$

b. First Derivative of P_{AE} with Respect to α . The first derivative of P_{AE} with respect to α may now be taken, and set equal to zero. The resulting expression is solved for the critical value of α . The first derivative is equal to

$$\frac{d \left[\frac{2P_{AE}}{\gamma(h^2 - d_c^2)} \right]}{d\alpha} = \frac{n \frac{dm}{d\alpha} - m \frac{dn}{d\alpha}}{n^2}$$

For this derivative to be equal to zero it is only necessary for $\left(n \frac{dm}{d\alpha} - \frac{dn}{d\alpha} \right)$ to be equal to zero. In order to simplify operations let:

$$1 + k_h \tan \phi = a, \quad \tan \phi - k_h = b, \quad \text{and} \quad 1 - \tan \phi \tan \beta = d$$

29 Sep 89

Then:

$$m = a \tan \alpha - b - \left(\frac{2c}{h + d_c} \right) (1 + \tan^2 \alpha)$$

$$n = \tan \phi \tan^2 \alpha + d \tan \alpha - \tan \beta$$

$$\frac{dm}{d\alpha} = \left[a - \left(\frac{4c}{h + d_c} \right) \tan \alpha \right] \sec^2 \alpha$$

$$\frac{dn}{d\alpha} = (2 \tan \phi \tan \alpha + d) \sec^2 \alpha$$

$$n \frac{dm}{d\alpha} = \left[a \tan \phi \tan^2 \alpha + ad \tan \alpha - a \tan \beta - \frac{4c}{\gamma(h + d_c)} \tan \phi \tan^3 \alpha \right. \\ \left. - \frac{4c}{\gamma(h + d_c)} d \tan^2 \alpha + \frac{4c}{\gamma(h + d_c)} \tan \beta \tan \alpha \right] \sec^2 \alpha$$

$$m \frac{dn}{d\alpha} = \left[2 a \tan \phi \tan^2 \alpha - 2b \tan \alpha \tan \alpha - \frac{4c}{\gamma(h + d_c)} \tan \phi \tan \alpha \right. \\ \left. - \frac{4c}{\gamma(h + d_c)} \tan \phi \tan^3 \alpha + ad \tan \alpha - bd - \frac{2c}{\gamma(h + d_c)} d \right. \\ \left. - \frac{2c}{\gamma(h + d_c)} d \tan^2 \alpha \right] \sec^2 \alpha$$

$$\begin{aligned} \frac{m \frac{dn}{d\alpha} - n \frac{dm}{d\alpha}}{\sec^2 \alpha} &= \left[-a \tan \phi - \frac{2c}{\gamma(h + d_c)} d \right] \tan^2 \alpha \\ &+ 2b \left[\tan \phi + \frac{4c}{\gamma(h + d_c)} (\tan \beta + \tan \phi) \right] \tan \alpha \\ &+ \left[-a \tan \beta + bd + \frac{2c}{\gamma(h + d_c)} d \right] = 0 \end{aligned}$$

Substitute $1 + k_h \tan \phi$ for a , $\tan \phi - k_h$ for b and $1 - \tan \phi \tan \beta$ for d

$$\begin{aligned} &\left[-(1 + k_h \tan \phi) \tan \phi - \frac{2c}{\gamma(h + d_c)} (1 - \tan \phi \tan \beta) \right] \tan^2 \alpha \\ &+ \left[2(\tan \phi - k_h) \tan \phi + \frac{4c}{\gamma(h + d_c)} (\tan \beta + \tan \phi) \right] \tan \alpha \\ &+ \left[-(1 + k_h \tan \phi) \tan \beta + (\tan \phi - k_h)(1 - \tan \phi \tan \beta) \right. \\ &\left. + \frac{2c}{\gamma(h + d_c)} (1 - \tan \phi \tan \beta) \right] = 0 \\ &\tan^2 \alpha - \left[\frac{2 \tan \phi (\tan \phi - k_h) + \frac{4c}{\gamma(h + d_c)} (\tan \phi + \tan \beta)}{(1 + k_h \tan \phi) \tan \phi + \frac{2c}{\gamma(h + d_c)} (1 - \tan \phi \tan \beta)} \right] \tan \alpha \\ &- \left[\frac{\tan \phi (1 - \tan \phi \tan \beta) - (k_h + \tan \beta) + \frac{2c}{\gamma(h + d_c)} (1 - \tan \phi \tan \beta)}{(1 + k_h \tan \phi) \tan \phi + \frac{2c}{\gamma(h + d_c)} (1 - \tan \phi \tan \beta)} \right] = 0 \end{aligned}$$

29 Sep 89

then

$$\alpha = \tan^{-1} \left[\frac{c_1 + \sqrt{c_1^2 + 4c_2}}{2} \right] \quad [G-17]$$

where

$$c_1 = \frac{2 \tan \phi (\tan \phi - k_h) + \frac{4c}{\gamma(h + d_c)} (\tan \phi + \tan \beta)}{(1 + k_h \tan \phi) \tan \phi + \frac{2c}{\gamma(h + d_c)} (1 - \tan \phi \tan \beta)} \quad [G-18]$$

$$c_2 = \frac{\tan \phi (1 - \tan \phi \tan \beta) - (k_h + \tan \beta) + \frac{2c}{\gamma(h + d_c)} (1 - \tan \phi \tan \beta)}{(1 + k_h \tan \phi) \tan \phi + \frac{2c}{\gamma(h + d_c)} (1 - \tan \phi \tan \beta)} \quad [G-19]$$

$$d_c = \frac{c}{(\sin \alpha \cos \alpha - \tan \phi \cos^2 \alpha) \gamma} \quad [G-20]$$

G-6. Equations for Critical Slip-Plane Angles for Resisting Wedges for Earthquake Condition. The equations for the critical slip-plane angle (α) for a resisting wedge are derived in the same manner used for the driving wedges. The resulting equations are

$$\alpha = \tan^{-1} \left[\frac{-c_1 + \sqrt{c_1^2 + 4c_2}}{2} \right] \quad [G-21]$$

$$A = (1 + k_h \tan \phi) \tan \phi + \frac{2c(1 + \tan \phi \tan \beta)}{\gamma h} \quad [G-22]$$

$$c_1 = \frac{2(\tan \phi - k_h) \tan \phi + \frac{4c(\tan \phi - \tan \beta)}{\gamma h}}{A} \quad [G-23]$$

$$c_2 = \frac{\tan \phi(1 + \tan \phi \tan \beta) + (\tan \beta - k_h) + \frac{2c(1 + \tan \phi \tan \beta)}{\gamma h}}{A} \quad [G-24]$$

G-7. Procedure for Finding the Critical Slip-Plane Angle, for a Wedge in a Layer Below the Top Layer, of a Stratified Backfill. A layered soil system is shown in the figure on the following page.

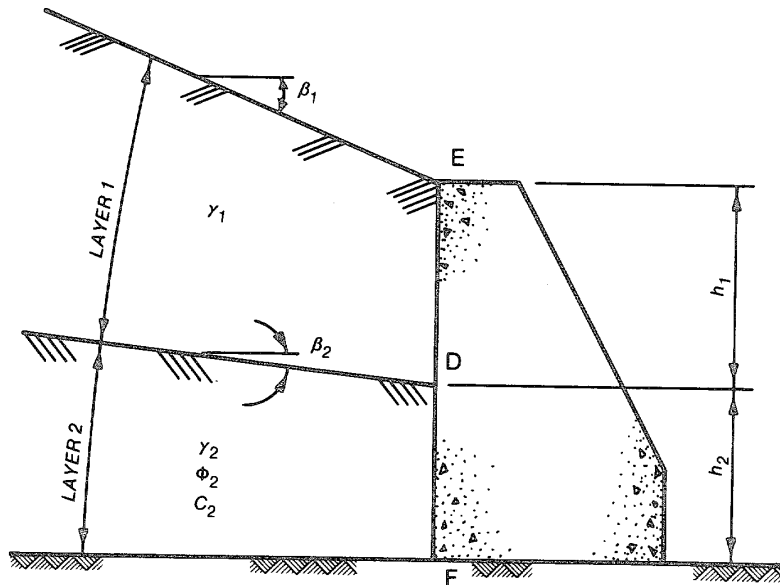

In order to find the critical slip-plane angle for layer 2, the weight of soil in layer 1 will be considered a surcharge supported by layer 2. See figure below.

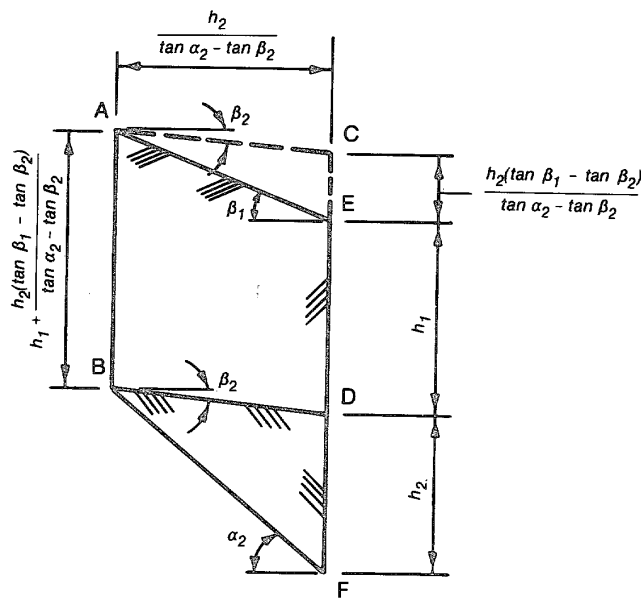

29 Sep 89

The weight of soil in parallelogram ABCD of the figure is a uniformly distributed surcharge that varies with α_2 . The uniformly distributed surcharge does not affect the angle α_2 , but does have the effect of increasing the unit weight of soil in wedge². The increased soil unit weight is calculated as follows.

γ' = increased unit weight

$$\frac{\gamma' h_2^2}{2 (\tan \alpha_2 - \tan \beta_2)} = \frac{\gamma_2 h_2^2}{2 (\tan \alpha_2 - \tan \beta_2)} + \gamma_1 h_2 \left[\frac{h_1 + \frac{h_2 (\tan \beta_1 - \tan \beta_2)}{\tan \alpha_2 - \tan \beta_2}}{\tan \alpha_2 - \tan \beta_2} \right]$$

$$\frac{\gamma' h_2^2}{2 (\tan \alpha_2 - \tan \beta_2)} = \frac{2\gamma_1 h_1 h_2 + \gamma_2 h_2^2}{2 (\tan \alpha_2 - \tan \beta_2)} + \frac{\gamma_1 h_2^2 (\tan \beta_1 - \tan \beta_2)}{(\tan \alpha_2 - \tan \beta_2)^2}$$

$$\gamma' = \frac{2\gamma_1 h_1}{h_2} + \gamma_2 + \frac{2\gamma_1 (\tan \beta_1 - \tan \beta_2)}{\tan \alpha_2 - \tan \beta_2} \quad [G-25]$$

The weight of soil in triangle ACE is considered to be a negative strip surcharge that also varies with α . The value of this strip surcharge is calculated as follows.

$$V_\alpha = - \frac{\gamma_1 h_2^2 (\tan \beta_1 - \tan \beta_2)}{2 (\tan \alpha_2 - \tan \beta_2)^2} \quad [G-26]$$

Using the terms γ' and V_α , we have a wedge whose critical slip-plane angle may be determined from Equations 3-25, 3-28, 3-29, and 3-30. See the figure on the following page.

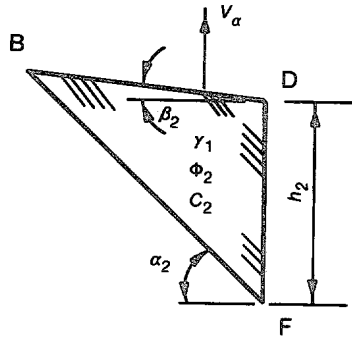

Equations 3-25, 3-28, 3-29, and 3-30 become:

$$A' = \tan \phi_2 + \frac{2c_2(1 + \tan^2 \phi_2)}{\gamma' h_2} - \frac{2V_\alpha(1 + \tan^2 \phi_2)}{\gamma' h_2^2} \quad [G-27]$$

$$c_1' = \frac{2 \tan^2 \phi_2 + \frac{4c_2(\tan \phi_2 + \tan \beta_2)}{\gamma' h_2} - \frac{4V_\alpha \tan \beta_2(1 + \tan^2 \phi_2)}{\gamma' h_2^2}}{A'} \quad [G-28]$$

$$c_2' = \frac{\tan \phi_2(1 - \tan \phi_2 \tan \beta_2) - \tan \beta_2 + \frac{2c_2(1 - \tan \phi_2 \tan \beta_2)}{\gamma' h_2} + \frac{2V_\alpha \tan^2 \beta_2(1 + \tan^2 \phi_2)}{\gamma' h_2^2}}{A'} \quad [G-29]$$

$$\alpha_2 = \tan^{-1} \left(\frac{c_1' + \sqrt{c_1'^2 + 4c_2'}}{2} \right) \quad [G-30]$$

Note that d_c (depth of crack in cohesive soil) is taken as zero in the above equations. This is based upon the assumption that horizontal compressive pressure, due to surcharge, is greater than any negative pressure that might develop due to cohesion.

a. Procedure:

- (1) Choose a trial value for α_2 .

(2) Using trial value of α_2 , calculate γ' (Equation G-10) and (Equation G-11) V_α .

(3) Using the values of γ' and V_α from step 2, calculate α_2 from Equations G-12, G-13, G-14, and G-15.

(4) If α_2 from step 3 is equal to α_2 in step 1 go to step 6. If α_2 from step 3 is not equal to α_2 in step 1 go to step 5.

(5) Use α_2 from step 3 as a new trial value in step 1, and repeat procedure.

(6) Stop. α_2 from step 3 is critical value.

b. Example: Find α_2 critical to nearest 0.5 degree.

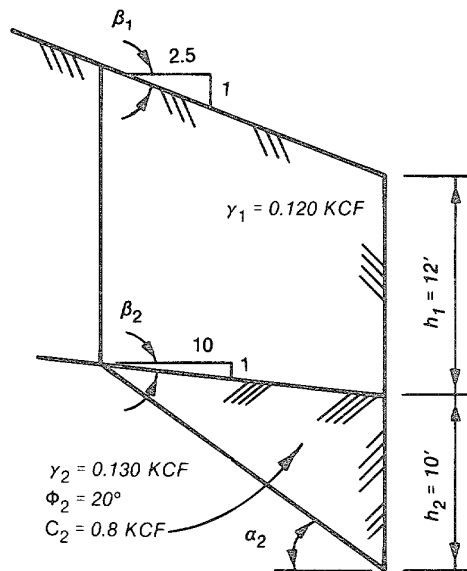

From Equation G-10,

$$\gamma' = \frac{2(0.12)(12)}{10} + 0.13 + \frac{2(0.12)(0.4 - 0.1)}{\tan \alpha_2 - 0.1}$$

$$\gamma' = 0.418 + \frac{0.072}{\tan \alpha_2 - 0.1}$$

From Equation G-11,

$$V_{\alpha} = - \frac{0.12(10)^2(0.4 - 0.1)}{2 (\tan \alpha_2 - 0.1)^2} = - \frac{1.80}{(\tan \alpha_2 - 0.1)^2}$$

(1) α_2 for long term loading ($\phi_2 = 20^\circ$, $c_2 = 0$)

(a) First trial: $\alpha_2 = 45^\circ$, $\gamma' = 0.4980$, $V_{\alpha} = -2.2222$

Using Equations G-12, G-13, G-14, and G-15,

$$A' = 0.36398 - \frac{2(-2.2222)(1.132474)}{0.4980(10)^2} = 0.465038$$

$$c'_1 = \frac{0.264948 - \frac{4(-2.2222)(0.1)(1.132474)}{0.4980(10)^2}}{0.465038} = 0.613200$$

$$c'_2 = \frac{0.36397(1 - 0.36397 \times 0.1) - 0.1 + \frac{2(-2.2222)(0.01)(1.132474)}{0.4980(10)^2}}{0.465038}$$

$$c'_2 = 0.536971 , \quad \alpha_2 = 47.75^\circ \quad 48^\circ \neq 45^\circ$$

(b) Second trial: $\alpha_2 = 48.0^\circ$, $\gamma' = 0.4892$, $V_{\alpha} = -1.7624$

$$A' = 0.36397 - \frac{0.022649(-1.7624)}{0.4892} = 0.445566$$

$$c'_1 = \frac{0.264948 - \frac{0.004530(-1.7684)}{0.4892}}{0.445566} = 0.631260$$

$$c'_2 = \frac{0.250723 + \frac{0.0002265(-1.7624)}{0.4892}}{0.445566} = 0.560875$$

29 Sep 89

$$\alpha_2 = 48.45^\circ \quad 48.5^\circ \neq 48^\circ$$

(c) Third trial: $\alpha_2 = 48.5^\circ$, $\gamma' = 0.4879$, $V_\alpha = 1.6957$

$$A' = 0.36397 - \frac{0.022649(-1.6957)}{0.4879} = 0.442687$$

$$c'_1 = \frac{0.264948 - \frac{0.004530(-1.6957)}{0.4879}}{0.442687} = 0.634064$$

$$c'_2 = \frac{0.250723 + \frac{0.0002265(-1.6957)}{0.4879}}{0.442687} = 0.564588$$

$$\alpha_2 = 48.56^\circ \quad 48.5^\circ$$

$$\underline{\underline{\alpha_2 = 48.5^\circ}}$$

(2) α_2 for short term loading ($\phi_2 = 0$, $c_2 = 0.8$ ksf)

(a) First trial: $\alpha_2 = 45^\circ$, $\gamma' = 0.4980$, $V_\alpha = -2.2222$

$$A' = \frac{2(0.8)}{0.498(10)} - \frac{2(-2.2222)}{0.498(10)^2} = 0.410530$$

$$c'_1 = 2 \tan \beta_2 = 0.2$$

$$c'_2 = \frac{-0.1 + \frac{2(0.8)}{0.498(10)} + \frac{2(-2.2222)(0.01)}{0.498(10)^2}}{0.410530} = 0.537936$$

$$\alpha_2 = 40.04^\circ \approx 40^\circ$$

(b) Second trial: $\alpha_2 = 40^\circ$, $\gamma' = 0.5154$, $V_\alpha = -3.2951$

$$A' = \frac{0.16}{0.5154} - \frac{0.02(-3.7218)}{0.5154} = 0.438304$$

$$c'_1 = 0.2 \text{ , } c'_2 = \frac{-0.1 + \frac{0.16}{0.5154} + \frac{0.0002(-3.2951)}{0.5154}}{0.438304} = 0.477203$$

$$\alpha_2 = 38.59^\circ \approx 38.5^\circ \neq 40^\circ$$

(c) Third trial: $\alpha_2 = 38.5^\circ$, $\gamma' = 0.5215$, $V_\alpha = -3.7218$

$$A' = \frac{0.16 - 0.02(-3.7218)}{0.5215} = 0.449542$$

$$c'_1 = 0.2 \text{ , } c'_2 = \frac{-0.1 + \frac{0.16 + 0.0002(-3.7218)}{0.5215}}{0.449542} = 0.456865$$

$$\alpha_2 = 38.07^\circ \approx 38^\circ \neq 38.5^\circ$$

(d) Fourth trial: $\alpha_2 = 38^\circ$, $\gamma' = 0.5237$, $V_\alpha = -3.8781$

$$A' = \frac{0.16 - 0.02(-3.8781)}{0.5237} = 0.453622$$

$$c'_1 = 0.2 \text{ , } c'_2 = \frac{-0.1 + \frac{0.16 + 0.0002(-3.8781)}{0.5237}}{0.453622} = 0.449796$$

$$\alpha_2 = 37.89^\circ \quad 38^\circ$$

$$\underline{\underline{\alpha_2 = 38^\circ}}$$

(3) Check $\alpha_2 = 48.5^\circ$ (for long term loading) using Equation 3-23

$$W = \frac{0.13(10)^2}{2 (\tan \alpha_2 - 0.1)} + \frac{0.12(12)(10)}{\tan \alpha_2 - 0.1} + \frac{0.12(10)^2 (\tan \beta_1 - \tan \beta_2)}{2 (\tan \alpha_2 - 0.1)^2}$$

$$W = \frac{20.9}{\tan \alpha_2 - 0.1} + \frac{1.8}{(\tan \alpha_2 - 0.1)^2}$$

$$P_{EE} = \frac{W (\tan \alpha_2 - \tan \phi_2)}{1 + \tan \phi_2 \tan \alpha_2}$$

$$\alpha_2 = 47.5^\circ: W = 22.9149 \text{ kips}$$

$$P_{EE} = \frac{22.9149(1.091309 - 0.36397)}{1 + 0.36397(1.091309)} = 11.9288 \text{ kips}$$

$$\alpha_2 = 48.5^\circ: W = 21.9812 \text{ kips}$$

$$P_{EE} = \frac{21.9812(1.130294 - 0.36397)}{1 + 0.36397(1.130294)} = 11.9348 \text{ kips} > 11.9288 \text{ kips}$$

$$\alpha_2 = 49.5^\circ: W = 21.0869 \text{ kips}$$

$$P_{EE} = \frac{21.0869(1.170850 - 0.36397)}{1 + 0.36397(1.170850)} = 11.9304 \text{ kips} < 11.9348$$

The critical α_2 equals 48.5° which checks with the value computed in paragraph G-7b(1)(c).

Check $\alpha_2 = 38^\circ$ (for short term loading) using Equation 3-23

29 Sep 89

$$W = \frac{20.9}{\tan \alpha_2 - 0.1} + \frac{1.8}{(\tan \alpha_2 - 0.1)^2}, \quad L = \frac{10}{\cos \alpha_2 (\tan \alpha_2 - 0.1)}$$

$$P_{EE} = W \tan \alpha_2 - c_2 L / \cos \alpha$$

$$\alpha_2 = 37^\circ: \quad W = 36.1931 \text{ kips}, \quad L = 19.1589 \text{ ft}$$

$$P_{EE} = 36.1931(0.753554) - \frac{0.8(19.1589)}{0.798636} = 8.0818 \text{ kips}$$

$$\alpha_2 = 38^\circ: \quad W = 34.5554 \text{ kips}, \quad L = 18.6268 \text{ ft}$$

$$P_{EE} = 34.5554(0.781286) - \frac{0.8(18.6268)}{0.788011} = 8.0875 \text{ kips} > 0.0818$$

$$\alpha_2 = 39^\circ: \quad W = 33.0185 \text{ kips}, \quad L = 18.1289 \text{ ft}$$

$$P_{EE} = 33.0185(0.809784) - \frac{0.8(18.1289)}{0.777146} = 8.0758 \text{ kips} < 8.0875$$

The critical α_2 equals 38° which checks with the value computed in paragraph G-7b(2)(d)

APPENDIX H

DERIVATION OF PRESSURE COEFFICIENTS FOR SOLUTION OF LATERAL
EARTH PRESSURE PROBLEMS

H-1. Introduction.

a. Engineers are familiar with earth pressure coefficients and their use in determining pressures and forces acting on retaining walls. The most familiar and most often used are:

$$K_A = \tan^2\left(45^\circ - \frac{\phi}{2}\right), \text{ for driving pressure}$$

$$K_P = \tan^2\left(45^\circ + \frac{\phi}{2}\right), \text{ for resisting pressure}$$

The above represent special cases of Coulomb's equations for earth pressure coefficients.

b. These simple coefficients are proper to use only when:

- (1) Backfill surface is a level plane.
- (2) Any surcharge applied to the surface is uniform, and covers the entire surface of the backfill wedge.

c. The general equations from which these simple coefficients are obtained are subject to the following limitations:

- (1) Backfill must be cohesionless, unless the top surface is horizontal.
- (2) Fill must be completely saturated or completely unsaturated, unless the top surface is horizontal.
- (3) Top can be a constant slope, but must be an unbroken plane.
- (4) Any surcharge must be uniform and cover the entire surface of the backfill wedge.

d. The correct lateral earth force due to any backfill wedge may be obtained from the general wedge equation, and the general wedge equation is subject to none of the above limitations. This equation may be used to solve the most complicated problems of wedge geometry and surface loading.

e. If lateral earth pressure coefficients are derived from the general wedge equation, these coefficients may be used in a rather simple manner to

solve complex earth pressure problems. The general wedge equation will now be derived and the pressure coefficients obtained from the derived equation.

H-2. Driving Side Earth Pressure.

- a. A typical driving wedge is shown in the figure below.

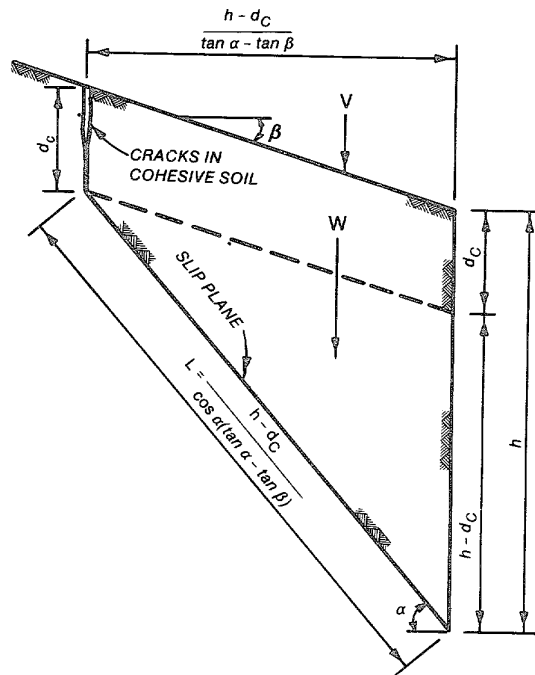

W = WEIGHT OF SOIL IN WEDGE,
 V = ANY SURFACE LOAD OTHER THAN
A UNIFORM SURCHARGE

In the derivation on the following pages it will be assumed that shear on the vertical face of the wedge is zero.

b. In the figure below, the forces acting on the wedge are shown along with their components parallel and normal to the slip plane.

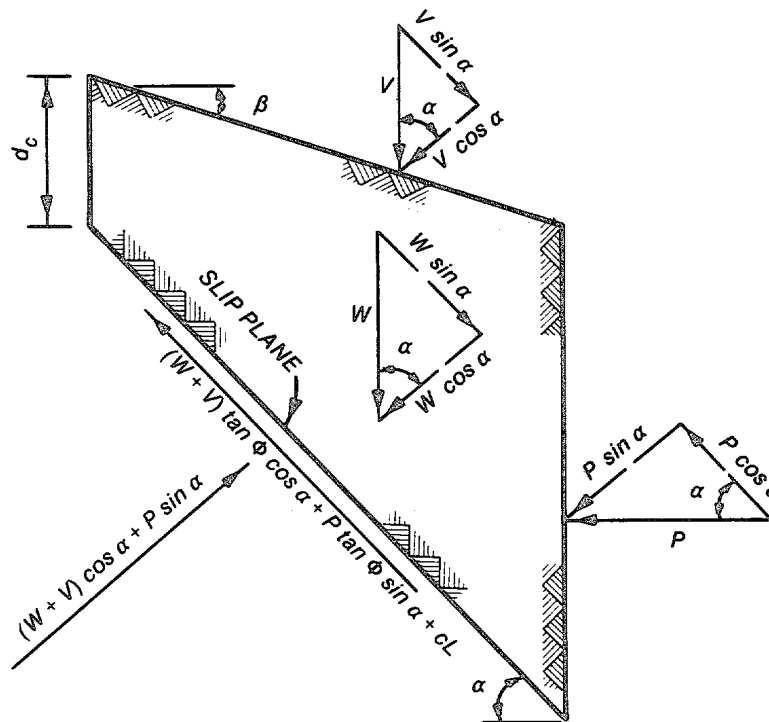

Setting the summation of forces parallel to the slip plane equal to zero:

$$P (\cos \alpha + \tan \phi \sin \alpha) + (W + V) (\tan \phi \cos \alpha - \sin \alpha) + cL = 0$$

Rearranging and solving for P :

$$P = \frac{(W + V) (\sin \alpha - \tan \phi \sin \alpha) - cL}{\cos \alpha + \tan \phi \sin \alpha}$$

From the previous figure:

$$L = \frac{h - d_c}{\cos \alpha (\tan \alpha \tan \beta)} \quad \text{and} \quad W = \frac{\gamma (h^2 - d_c^2)}{2 (\tan \alpha - \tan \beta)}$$

29 Sep 89

where

γ = unit weight of wedge material
 c = cohesion

The equation for P will now be rewritten with the individual terms for W , V , and c separated.

$$P = \frac{\gamma(h^2 - d_c^2)}{2} \cdot \frac{\sin \alpha - \tan \phi \cos \alpha}{\cos \alpha + \tan \phi \sin \alpha} \cdot \frac{1}{\tan \alpha - \tan \beta}$$

$$+ \frac{V(\sin \alpha - \tan \phi \cos \alpha)}{\cos \alpha + \tan \phi \sin \alpha}$$

$$- \frac{c(h - d_c)}{\cos \alpha (\tan \alpha - \tan \beta) (\cos \alpha + \tan \phi \sin \alpha)}$$

This may be simplified and rewritten as:

$$P = \frac{\gamma(h^2 - d_c^2)}{2} \cdot \frac{1 - \tan \phi \cot \alpha}{1 + \tan \phi \tan \alpha} \cdot \frac{\tan \alpha}{\tan \alpha - \tan \beta}$$

$$+ \frac{V(1 - \tan \phi \cot \alpha) \tan \alpha}{1 + \tan \phi \tan \alpha}$$

$$- \frac{2c(h - d_c) \tan \alpha}{2 \sin \alpha \cos \alpha (1 + \tan \phi \tan \alpha) (\tan \alpha - \tan \beta)} \quad [H-1]$$

c. Everything in the first term except $\gamma(h^2 - d_c^2)/2$ is the lateral earth coefficient for γ and will be called K_1 . Everything in the second term except V is the lateral coefficient for the strip surcharge and will be called K_v . Everything in the third term except $2c(h - d_c)$ is the lateral coefficient for cohesion and will be called K_c .

d. Note that K_1 and K_v both contain the term $\left(\frac{1 - \tan \phi \cot \alpha}{1 + \tan \phi \tan \alpha}\right)$.

This is the lateral coefficient for γ when the top surface is a level unbroken plane. This term will be called K . Therefore:

$$K_1 = K \left(\frac{\tan \alpha}{\tan \alpha - \tan \beta} \right)$$

$$K_v = K \tan \alpha$$

e. Note also that K_1 and K_c both contain the term:

$$\frac{\tan \alpha}{\tan \alpha - \tan \beta}$$

This term which modifies K_1 and K_c for the effect of surface slope. It becomes unity when $\beta = 0$.

f. The equation for the total lateral force (P) produced by a driving wedge can now be written, where the wedge material possesses both cohesion and internal friction, where the top surface is a sloping plane, where the top surface supports a strip surcharge, and where the wedge is either completely saturated or completely unsaturated. The equation is:

$$P = \frac{K_1 \gamma (h^2 - d_c^2)}{2} + K_v V - 2K_c c (h - d_c) \quad [H-2]$$

g. The individual forces and pressure distributions are shown in the figure on the following page.

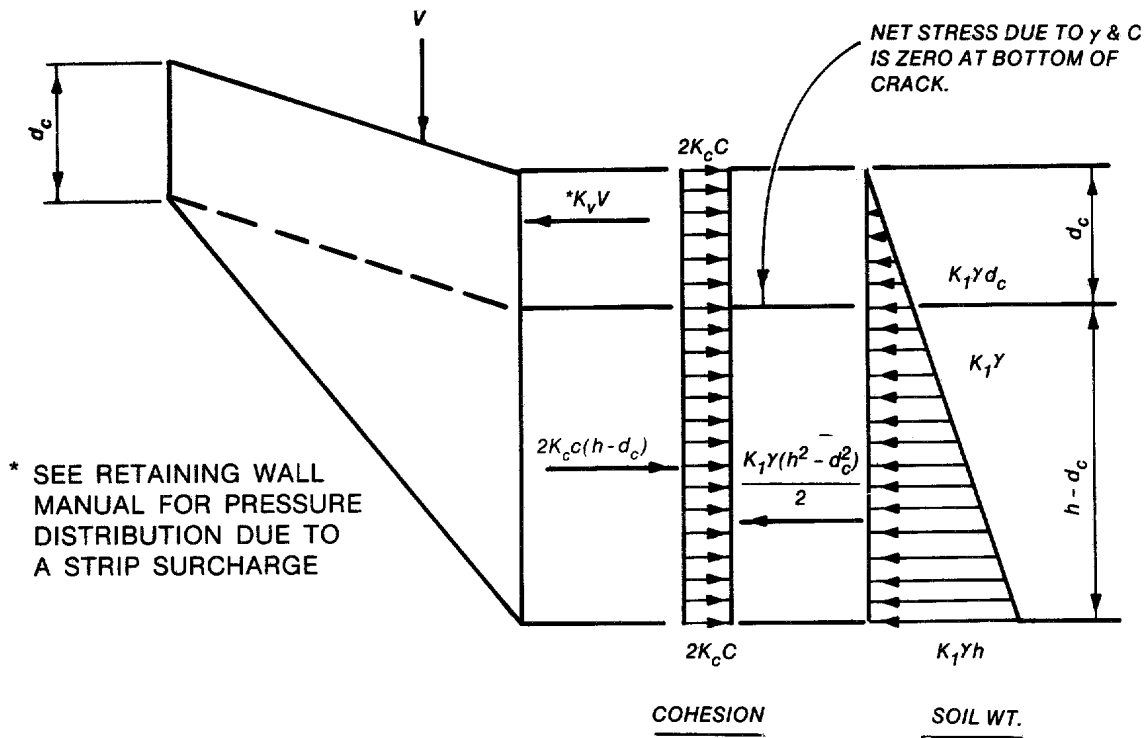

h. The lateral coefficient (K_b) to apply to the effective weight of fill (γ_b) below the saturation level in a partially saturated wedge will now be determined. If the water table rises in a wedge that was previously unsaturated, the lateral earth force will be reduced by the same amount on both sides of the wedge. The slope of the earth pressure diagram, acting on the vertical projection of the wedge slip plane, is $K\gamma$ above the saturation level and $K\gamma_b$ below the saturation level. The slope of the earth pressure diagram, acting on the vertical face of the wedge, is $K_1\gamma$ above the saturation level and $K_b\gamma_b$ below the saturation level. See the figure on the following page.

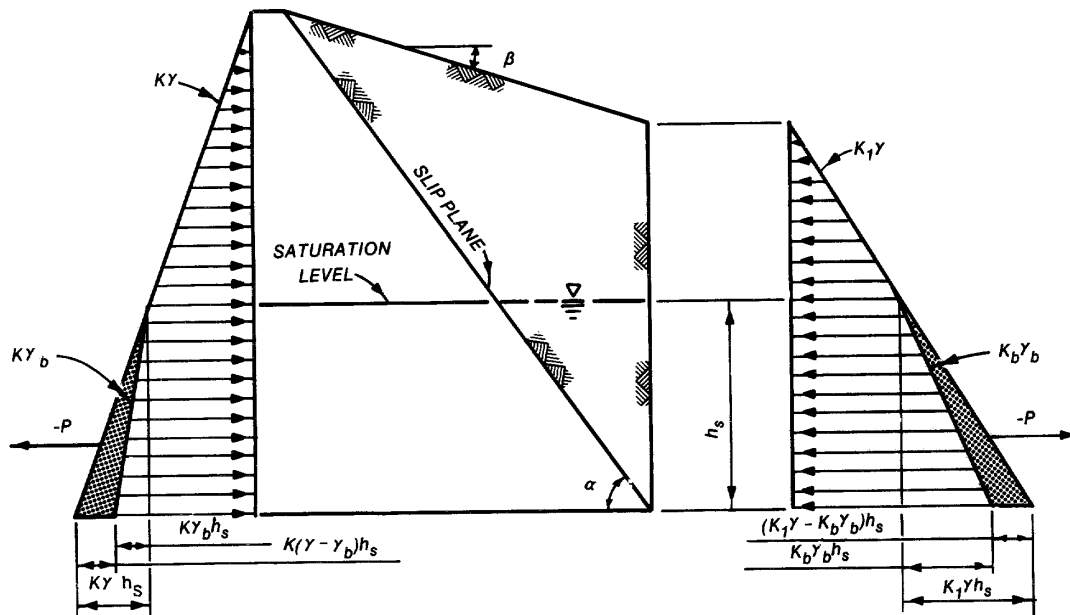

The force reduction on each side of the wedge (-P) is represented by the shaded parts of the pressure diagrams.

$$\frac{K(\gamma - \gamma_b)h_s^2}{2} = \frac{(K_1\gamma - K_b\gamma_b)h_s^2}{2}, \quad K_b\gamma_b = K_1\gamma - K\gamma + K\gamma_b$$

$$K_b = (K_1 - K)\left(\frac{\gamma}{\gamma_b}\right) + K$$

$$K_b = K \left[1 + \left(\frac{\tan \alpha}{\tan \alpha - \tan \beta} - 1 \right) \left(\frac{\gamma}{\gamma_b} \right) \right]$$

i. Summarizing, the coefficients for driving wedges are:

$$K = \frac{1 - \tan \phi \cot \alpha}{1 + \tan \phi \tan \alpha}, \quad \text{basic value}$$

$$K_1 = K \left(\frac{\tan \alpha}{\tan \alpha - \tan \beta} \right), \quad \text{apply to moist fill above saturation level}$$

$$K_b = K \left[1 + \left(\frac{\tan \alpha}{\tan \alpha - \tan \beta} - 1 \right) \left(\frac{\gamma}{\gamma_b} \right) \right], \text{ apply to buoyant weight of fill}$$

below the saturation level.

$K = K \tan \alpha$, multiply times V to obtain lateral force due to strip
surcharge

$$K_c = \frac{1}{2 \sin \alpha \cos \alpha (1 + \tan \phi \tan \alpha)} \cdot \frac{\tan \alpha}{\tan \alpha - \tan \beta}, \text{ multiply times } 2c$$

to obtain negative pressure due to cohesion.

j. A problem remains that must be solved before the coefficients can be used for calculating driving pressures and forces, and that problem is the value of the critical slip-plane angle. The critical angle is the angle which produces the maximum driving force. The equations for calculating this angle are derived in Appendix G and presented in Chapter 3 of the manual, and are as follows:

$$\alpha = \tan^{-1} \left(\frac{c_1 + \sqrt{c_1^2 + 4c_2}}{2} \right) \quad [3-25]$$

where

$$c_1 = \left[2 \tan^2 \phi_d + \frac{4c_d(\tan \phi_d + \tan \beta)}{\gamma(h + d_c)} - \frac{4V \tan \beta (1 + \tan^2 \phi_d)}{\gamma(h^2 - d_c^2)} \right] \div A \quad \text{Equation 3-28}$$

$$c_2 = \left[\tan \phi_d (1 - \tan \phi_d \tan \beta) - \tan \beta + \frac{2c_d(1 - \tan \phi_d \tan \beta)}{\gamma(h + d_c)} + \frac{2V \tan^2(\beta (1 + \tan^2 \phi_d))}{\gamma(h^2 - d_c^2)} \right] \div A \quad \text{Equation 3-29}$$

and

$$A = \tan \phi_d + \frac{2c_d(1 - \tan \phi_d \tan \beta)}{\gamma(h + d_c)} - \frac{2V(1 + \tan^2 \phi_d)}{\gamma(h^2 - d_c^2)} \quad [3-30]$$

k. The effect of water is accounted for by using the average unit weight of soil for γ in the above equations. The average unit weight is based on the moist unit weight of soil above the water table and the buoyant unit weight below the water table. The effect of seepage should be considered in determining the buoyant weight.

H-3. Resisting Side Earth Pressure.

a. Pressure Coefficients. The pressure coefficients for the resisting side are

$$K = \frac{1 + \tan \phi \cot \alpha}{1 - \tan \phi \tan \alpha}, \quad K_1 = K \left(\frac{\tan \alpha}{\tan \alpha - \tan \beta} \right)$$

$$K_v = K \tan \alpha$$

$$K_b = K \left[1 + \left(\frac{\tan \alpha}{\tan \alpha - \tan \beta} - 1 \right) \left(\frac{\gamma}{\gamma_b} \right) \right]$$

$$K_c = \frac{1}{2 \sin \alpha \cos \alpha (1 - \tan \phi \tan \alpha)} \cdot \frac{\tan \alpha}{\tan \alpha - \tan \beta}$$

The term for cohesion ($2K_c c$) is positive for resisting pressure calculations, not negative as it was for driving pressure. Therefore, the crack of depth d_c does not exist on the resisting side.

b. Critical Slip-Plane Angle. The equation for the critical slip-plane angle for a resisting side wedge is

$$\alpha = \tan^{-1} \left(\frac{-c_1 + \sqrt{c_1^2 + 4c_2}}{2} \right)$$

EM 1110-2-2502
29 Sep 89

Values for c_1 and c_2 are determined from the equations in Appendix G.

c. With the above changes, the method for determining resisting pressures and forces is the same as for the driving case.

APPENDIX I

DERIVATION OF EQUATION FOR DEPTH OF CRACK d_c IN COHESIVE SOIL

I-1. Definition. By definition, the bottom of the crack will lie at the depth where the net horizontal stress in the soil is zero.

$$P_h = K_1 \gamma d_c - 2K_c c = 0 \quad [I-1]$$

where

$$K_1 = \frac{1 - \tan \phi \cot \alpha}{1 + \tan \phi \tan \alpha} \cdot \frac{\tan \alpha}{\tan \alpha - \tan \beta}$$

$$K_c = \frac{\tan \alpha}{2 \sin \alpha \cos \alpha (1 + \tan \phi \tan \alpha) (\tan \alpha - \tan \beta)}$$

The coefficients K_1 and K_c are derived in Appendix H. Rearranging Equation I-1 and solving for d_c yields:

$$d_c = \frac{2K_c c}{K_1 \gamma} \quad [I-2]$$

Equation I-2 is valid for a sloping soil layer.

I-2. Horizontal top surface. When the top surface is horizontal,

$$K_1 = K_A \text{ (Coulomb)}$$

$$K_c = \sqrt{K_A}$$

and

$$d_c = \frac{2c}{\sqrt{K_A} \gamma}$$

APPENDIX J

LATERAL PRESSURES DUE TO COMPACTION

J-1. Design pressure envelope. The design pressure envelope for nonyielding walls with compaction effects will be derived. The lateral pressure due to at-rest conditions is shown in Figure J-1.

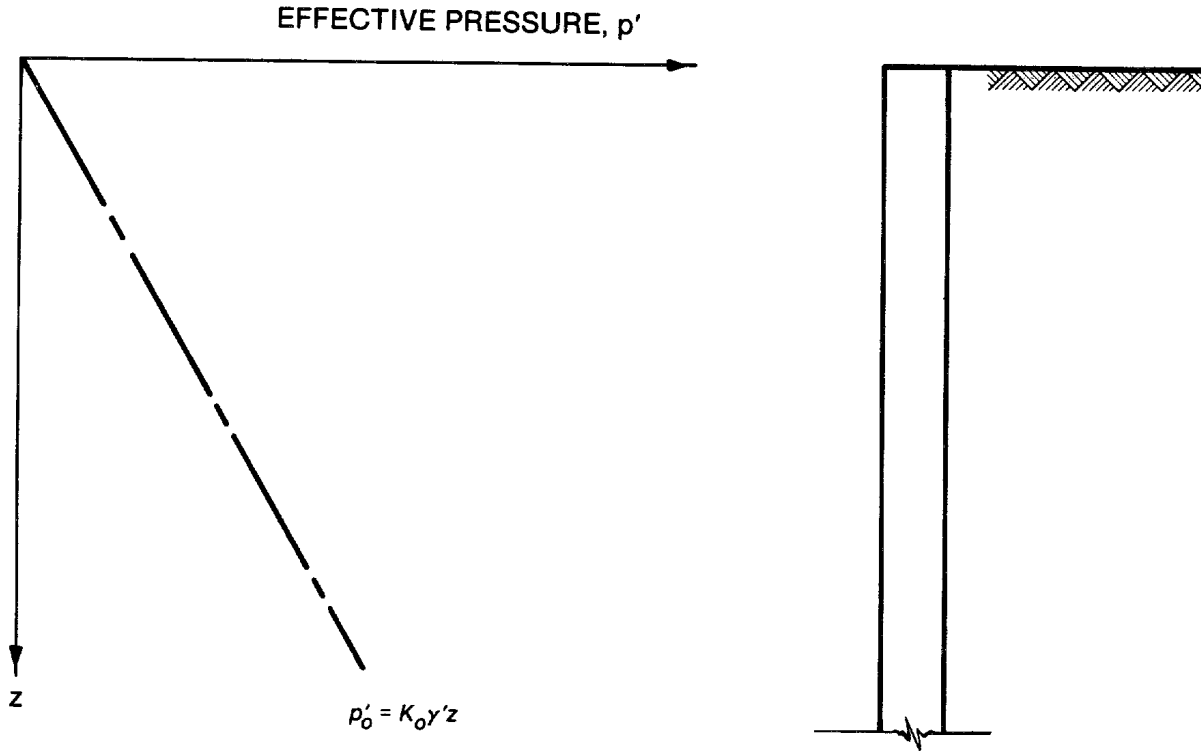

Figure J-1. Lateral pressure due to at-rest conditions
($\gamma' = \gamma$ above water table).

The lateral pressure induced by a compaction roller line load is shown in Figure J-2.

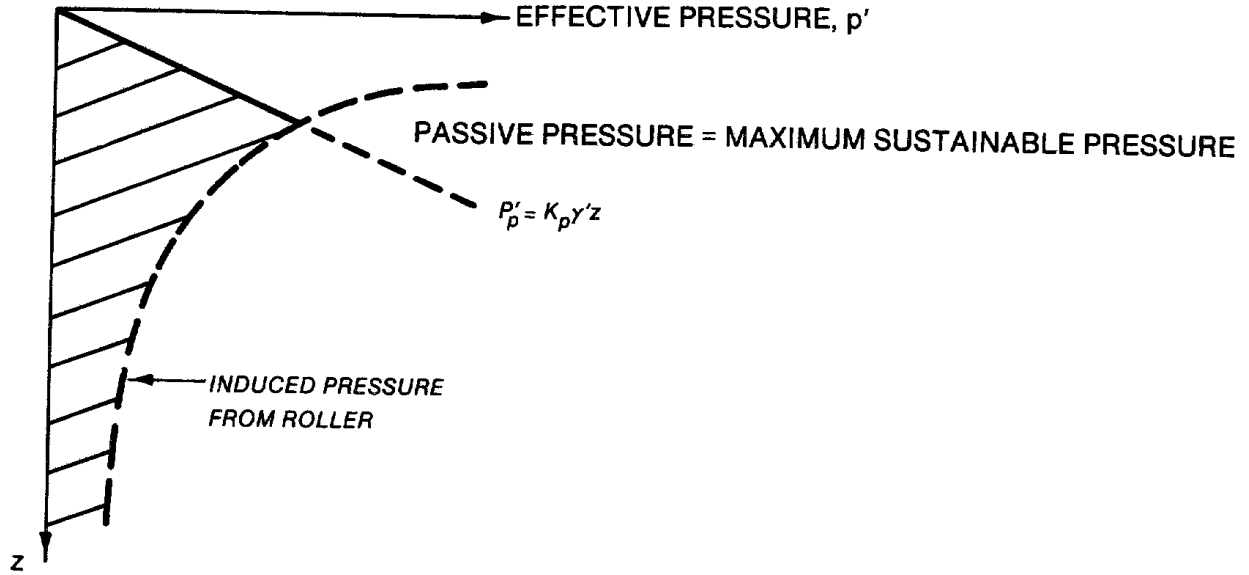

Figure J-2. Lateral pressure induced by compaction roller line load.

In Figure J-2,

$$\Delta P'_v = \frac{2P}{\pi z} \quad \text{where } P \text{ is the roller load, lb/linear ft}$$

$$\Delta P'_h = \frac{2K_o P}{\pi z} \quad \text{where } P \text{ is the roller load, lb/linear ft}$$

The maximum lateral pressure occurs at z_{cr} and the passive pressure is

$$P'_p = K_p \gamma' z \quad [J-1]$$

Taking

$$K_p = \frac{1}{K_A}$$

and inserting this into Equation J-1 yields

$$P'_p = \frac{\gamma' z}{K_A} \quad [J-2]$$

The horizontal pressure due to the earth and roller is

$$P'_h = K_o \gamma' z + \frac{2K_o P}{\pi z} \quad [J-3]$$

Using Equations J-2 and J-3 and solving for the critical depth z_{cr} yields

$$\frac{\gamma' z_{cr}}{K_a} = K_o \gamma' z_{cr} + \frac{2K_o P}{\pi z_{cr}}$$

$$\gamma' z_{cr}^2 = K_a K_o \gamma' z_{cr}^2 + \frac{2K_a K_o P}{\pi}$$

$$\gamma' z_{cr}^2 (1 - K_a K_o) = \frac{2K_a K_o P}{\pi}$$

Assuming $(1 - K_a K_o) \approx 1$

$$z_{cr} = \sqrt{\frac{2K_a K_o P}{\pi \gamma'}}$$

The horizontal pressure at z_{cr} is

$$P'_h = \frac{\gamma' z_{cr}}{K_a} = \sqrt{\frac{2K_o P \gamma'}{K_a \pi}}$$

The maximum pressure is constant below z_{cr} until it is exceeded by at-rest pressure, because the foregoing analysis represents each successive top lift. The design pressure envelope for nonyielding walls including the effects of compaction is shown in Figure J-3.

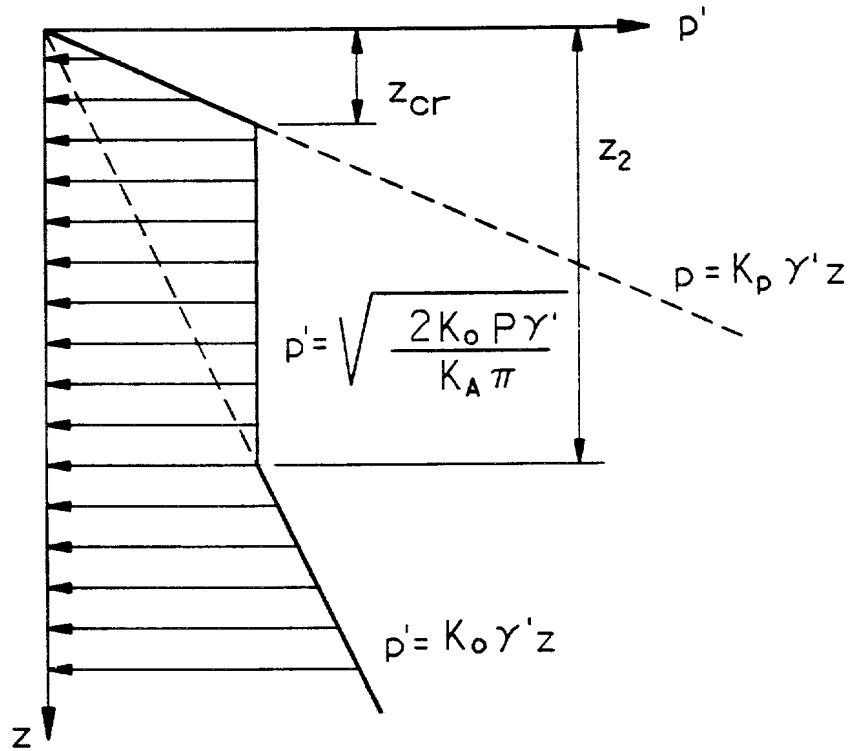

$$z_{cr} = \sqrt{\frac{2K_A K_o P}{\pi \gamma}}$$

$$z_2 = \sqrt{\frac{2P}{K_A K_o \pi \gamma'}}$$

Figure J-3. Design pressure envelope for nonyielding walls with compaction effects.

APPENDIX K

DERIVATION OF VERTICAL SHEAR FORCE FOR UPWARD SLOPING BACKFILL

K-1. Derivation for Shear Required on Vertical Faces of Earth Wedges. When the vertical face of an earth wedge does not lie on the same plane as the face of the structural wedge, a shear force is required in order that the horizontal earth force may be transferred between wedges.

A general situation where such a force is required is shown below in Figure K-1.

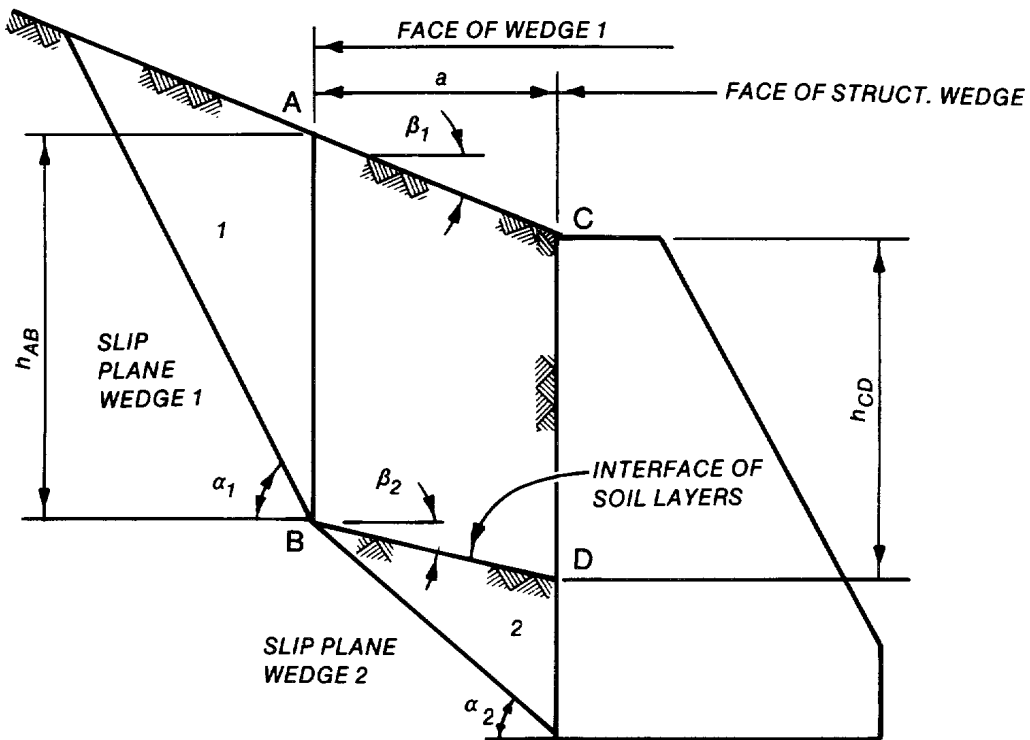

Figure K-1. General condition where shear force is required

The earth force calculated for wedge 1, using the provisions of the text, is a force acting on Surface AB. In order for the same force to act on Surface CD, a shear force must exist on vertical planes in Block ABCD. A free body of Block ABCD is shown in Figure K-2.

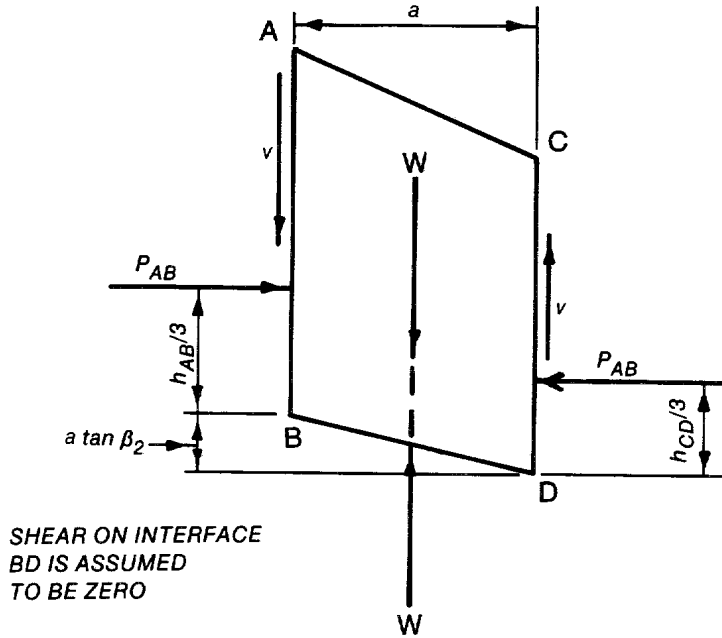

Figure K-2. Free body of Block ABCD.

Taking moments about D:

$$P_{AB} \left[\left(\frac{h_{AB}}{3} + a \tan \beta_2 \right) - \frac{h_{CD}}{3} \right] - va = 0$$

where

$$h_{CD} = h_{AB} - a (\tan \beta_1 - \tan \beta_2)$$

then

$$P_{AB} \left(\frac{h_{AB}}{3} + a \tan \beta_2 - \frac{h_{AB} - a \tan \beta_1 + a \tan \beta_2}{3} \right) = va$$

$$P_{AB} \left(a \tan \beta_2 + \frac{a \tan \beta_1}{3} - \frac{a \tan \beta_2}{3} \right) = va$$

$$v = \frac{P_{AB}(\tan \beta_1 + 2 \tan \beta_2)}{3}$$

See example 6 in Appendix M and example 1 in Appendix N for applications of the above equation.

APPENDIX L

DERIVATION OF GENERAL WEDGE EQUATION FOR MULTIPLE WEDGE ANALYSIS

L-1. Free-body diagram. A free-body diagram of an i^{th} wedge is shown below:

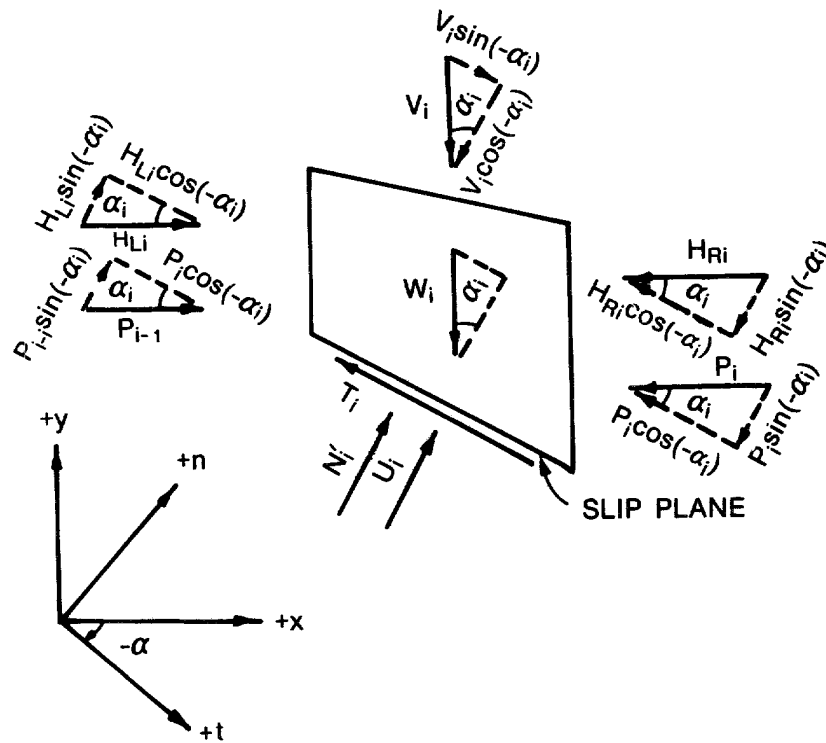

Writing equilibrium equations normal and parallel to slip plane,

$$\Sigma F_n = 0 :$$

$$0 = N_i + U_i - W \cos (-\alpha_i) - V_i \cos (-\alpha_i) + H_{Li} \sin (-\alpha_i) - H_{Ri} \sin (-\alpha_i) + P_{i-1} \sin (-\alpha_i) - P_i \sin (-\alpha_i)$$

Using the trigonometric relationships,

$$\cos (-\alpha_i) = \cos \alpha$$

and

$$\sin (-\alpha) = -\sin \alpha$$

$$N_i = (W_i + V_i) \cos (\alpha_i) - (H_{Li} - H_{Ri}) (-\sin \alpha_i) - (P_{i-1} - P_i) (-\sin \alpha_i) - U_i$$

$$\Sigma F_t = 0 :$$

$$0 = -T_i + W_i \sin (-\alpha_i) + V_i \sin (-\alpha_i) + H_{Li} \cos (-\alpha_i) \\
 - H_{Ri} \cos (-\alpha_i) + P_{i-1} \cos (-\alpha_i) - P_i \cos (-\alpha_i)$$

$$T_i = (W_i + V_i) (-\sin \alpha_i) + (H_{Li} - H_{Ri}) \cos \alpha_i + (P_{i-1} - P_i) \cos \alpha_i$$

According to the Mohr-Coulomb failure criterion,

$$T_F = N_i \tan \phi_i + c_i L_i$$

Writing the equation for the sliding factor of safety,

$$FS_i = \frac{T_F}{T_i} = \frac{N_i \tan \phi_i + c_i L_i}{T_i}$$

where FS_i = factor of safety.

Substituting the expressions for T_i and N_i into the equation for FS_i yields

$$FS_i = \frac{\left[(W_i + V_i) \cos \alpha_i + (H_{Li} - H_{Ri}) \sin \alpha_i + (P_{i-1} - P_i) \sin \alpha_i - U_i \right] \tan \phi_i + c_i L_i}{-(W_i + V_i) \sin \alpha_i + (H_{Li} - H_{Ri}) \cos \alpha_i + (P_{i-1} - P_i) \cos \alpha_i}$$

Solving for $(P_{i-1} - P_i)$,

$$\begin{aligned} (P_{i-1} - P_i) &= \left[(W_i + V_i) (\tan \phi_{di} \cos \alpha_i + \sin \alpha_i) - U_i \tan \phi_{di} \right. \\ &\quad \left. + (H_{Li} - H_{Ri}) \times (\tan \phi_{di} \sin \alpha_i - \cos \alpha_i) + c_{di} L_i \right] \\ &\div [\cos \alpha_i - \tan \phi_{di} \sin \alpha_i] \end{aligned} \quad [L-1]$$

Equation L-1 is the general wedge equation.

APPENDIX M

LATERAL EARTH PRESSURE COMPUTATIONS, EXAMPLES

SUMMARY OF EXAMPLES

Example 1, Page M-3

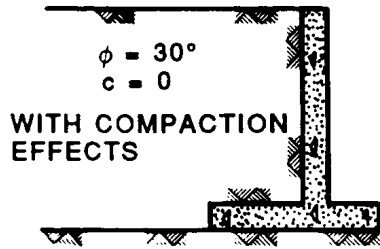

Example 4, Page M-11

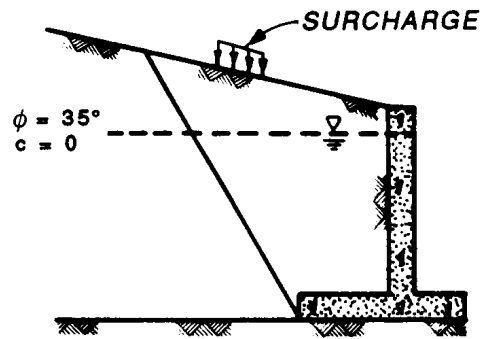

Example 2, Page M-5

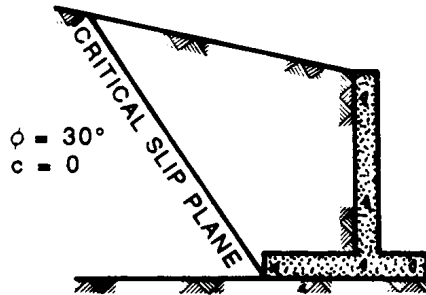

Example 5, Page M-21

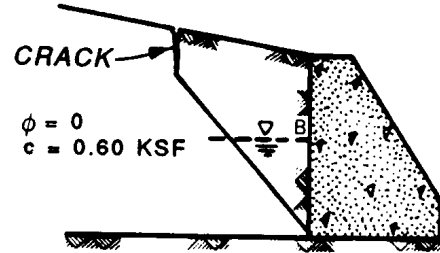

Example 3, Page M-7

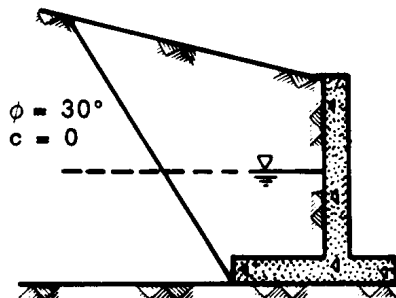

Example 6, Page M-28

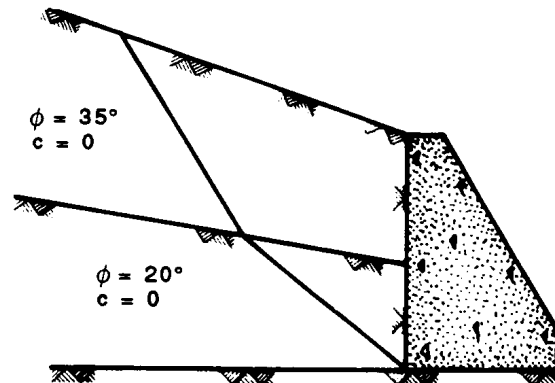

Example 7, Page M-35

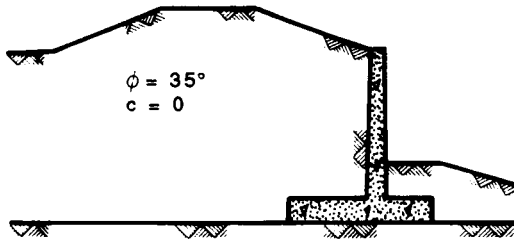

Example 10, Page M-58

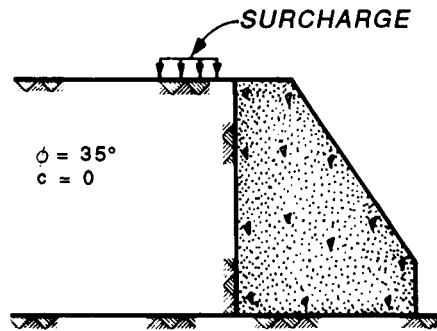

Example 8, Page M-41

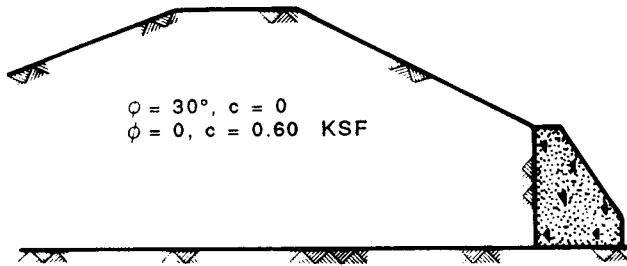

Example 11, Page M-64

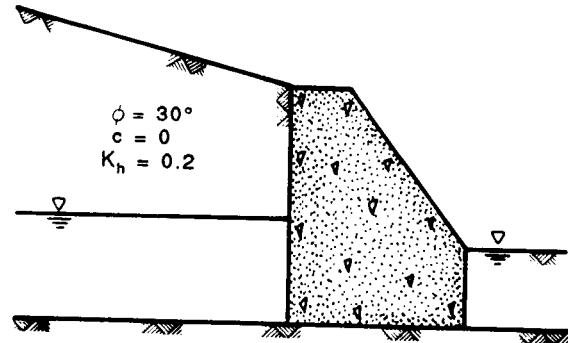

Example 9, Page M-52

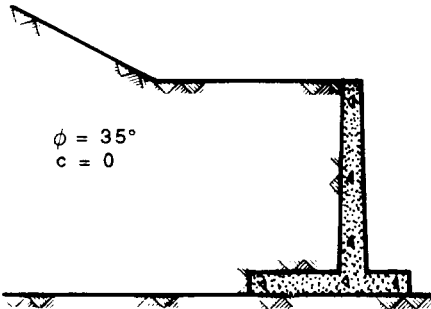

LATERAL EARTH PRESSURE COMPUTATIONS, EXAMPLES

M-1. EXAMPLE 1. Find the Lateral Earth Force and its pressure distribution on Surface AB. Consider the effects of compaction in accordance with paragraph 3-17.

P = Line load for compaction roller = 5 k/ft

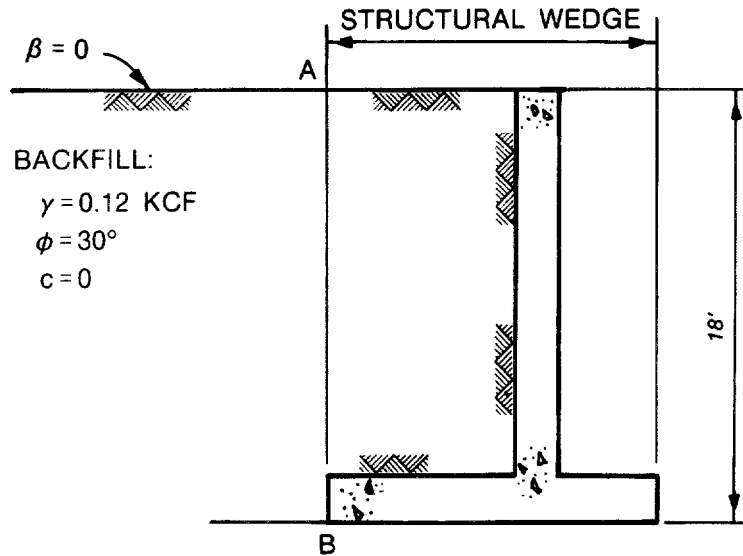

a. Active and passive pressure coefficients.

$$SMF = 1.00, \quad \phi_d = \phi = 30^\circ$$

$$K_A = \tan^2 (45^\circ - \phi_d/2) = 1/3 \quad [3-15]$$

$$K_P = \tan^2 (45^\circ + \phi_d/2) = 3 \quad [3-20]$$

b. At-rest earth pressure coefficient.

$$SMF = 2/3, \quad \phi_d = \tan^{-1} (2/3 \tan \phi) = 21^\circ \text{ (from paragraph 3-11c)}$$

$$K_o = \tan^2 (45^\circ - \phi_d/2) = 0.47$$

c. Calculation of earth pressures. From Figure 3-30:

$$z_{cr} = \sqrt{\frac{2K_A K_o P}{\pi \gamma}} = \sqrt{\frac{2/3 (0.47) (5)}{\pi (0.12)}} = 2.04 \text{ ft}$$

$$z_2 = \sqrt{\frac{2P}{K_A K_o \pi \gamma}} = \sqrt{\frac{2(5)}{1/3 (0.47) (\pi) (0.12)}} = 13.01 \text{ ft}$$

$$P'_{hm} = \sqrt{\frac{2K_o P \gamma}{K_A \pi}} = \sqrt{\frac{2(0.47)(5)(0.12)}{(1/3)\pi}} = 0.734 \text{ ksf}$$

The force and pressure distribution are shown below:

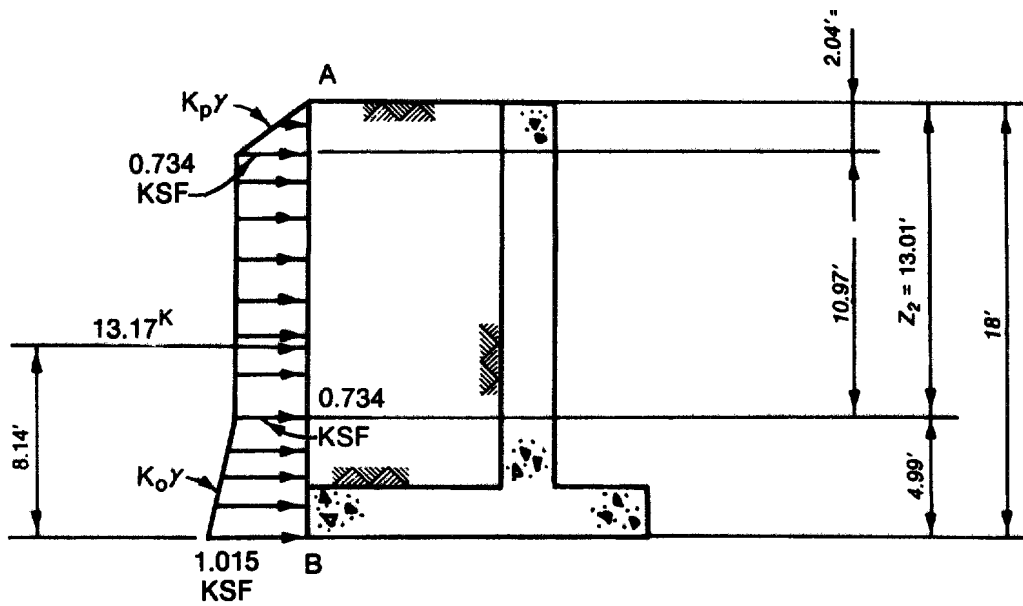

M-2. EXAMPLE 2. Find the lateral earth force and pressure distribution acting on Surface AB.

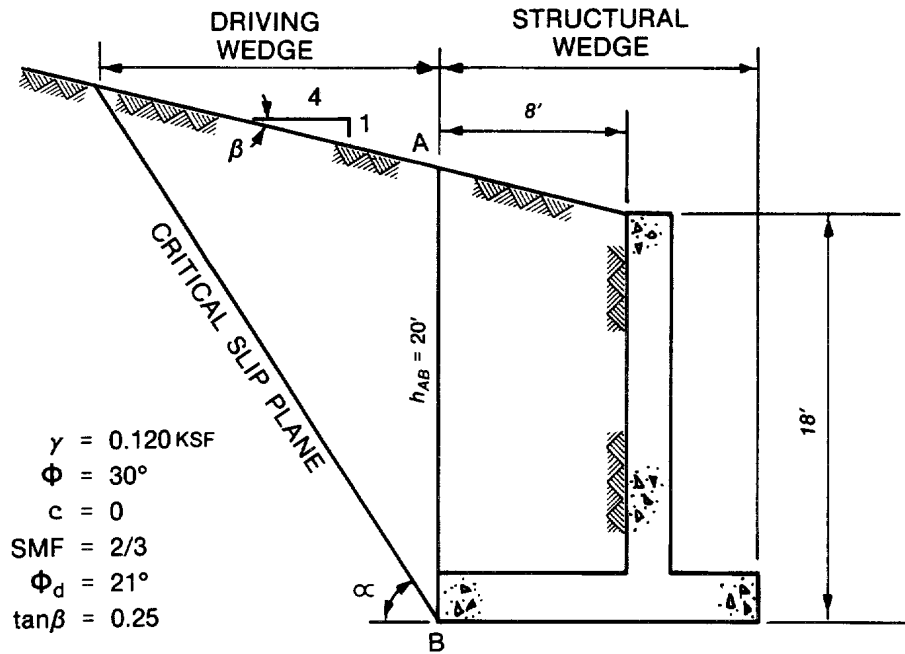

a. Calculate α .

$$c_1 = 2 \tan \phi_d = 2(0.383864) = 0.767728 \quad [3-26]$$

$$c_2 = 1 - \tan \phi_d \tan \beta - \frac{\tan \beta}{\tan \phi_d} \quad [3-27]$$

$$c_2 = 1 - 0.383864(0.25) - \frac{0.25}{0.383864} = 0.252762$$

$$\alpha = \tan^{-1} \left(\frac{c_1 + \sqrt{c_1^2 + 4c_2}}{2} \right) = 45.466^\circ \quad [3-25]$$

b. Lateral earth pressure coefficient (see Appendix H). From the equations contained in Appendix H:

$$K_1 = \left(\frac{1 - \tan \phi_d \cot \alpha}{1 + \tan \phi_d \tan \alpha} \right) \left(\frac{\tan \alpha}{\tan \alpha - \tan \beta} \right)$$

$$K_1 = \left(\frac{1 - 0.383864 \times 0.983864}{1 + 0.383864 \times 1.016400} \right) \left(\frac{1.016400}{0.766400} \right) = 0.5937$$

Alternatively K_1 may be calculated using Equation 3-14:

$$K_1 = \frac{\cos^2 \phi_d}{\left[1 + \sqrt{\frac{\sin \phi_d \sin (\phi_d - \beta)}{\cos \beta}} \right]^2}$$

$$\beta = \tan^{-1} (0.25) = 14.0362^\circ, \quad \phi_d - \beta = 6.9638^\circ$$

$$K_1 = \frac{(0.933580)^2}{\left[1 + \sqrt{\frac{0.358368(0.121242)}{0.970143}} \right]^2} = 0.5937$$

c. Lateral force and pressure distribution. The lateral force and pressure distribution are shown in the figure below:

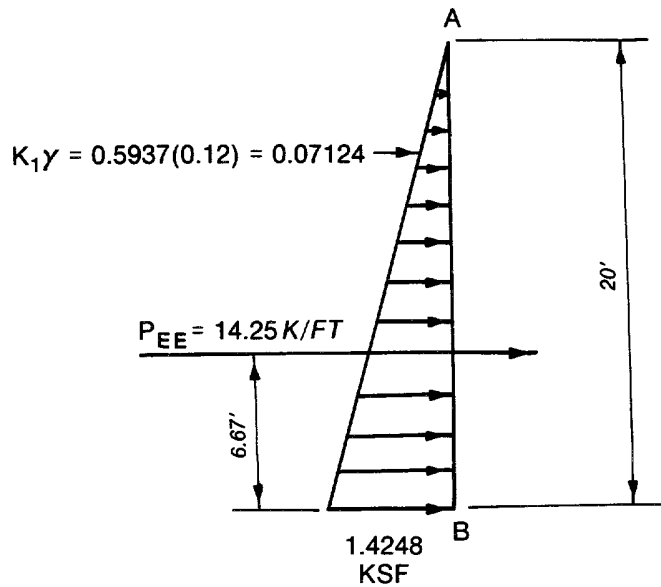

b. Lateral forces and pressure distribution. The lateral forces and pressure distribution are shown in the figure below:

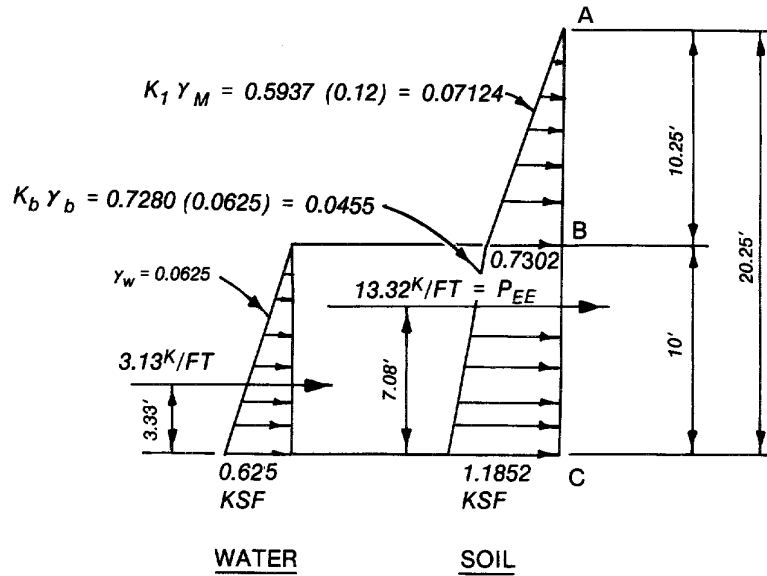

c. Check soil force by iterating Equation 3-23.

W = total wedge weight, including water

$$W = \frac{\gamma_m h^2 AC}{2 (\tan \alpha - \tan \beta)} + \frac{(\gamma_{sat} - \gamma_m) h_s^2}{2 \tan \alpha}$$

$$W = \frac{0.12(20.25)^2}{2 (\tan \alpha - \tan \beta)} + \frac{(0.005)(10)^2}{2 \tan \alpha} = \frac{24.604}{\tan \alpha - \tan \beta} + \frac{0.25}{\tan \alpha}$$

$$U = \text{uplift} = \frac{\gamma_{water} h_s^2}{2 \sin \alpha} = \frac{0.0625(10)^2}{2 \sin \alpha} = \frac{3.125}{\sin \alpha}$$

$$P_w = \frac{\gamma_{water} h_s^2}{2} = \frac{0.0625(10)^2}{2} = 3.125 \text{ k/ft}$$

$$P_{EE} = \frac{W (\tan \alpha - \tan \phi_d) + U \tan \phi_d / \cos \alpha}{1 + \tan \phi_d \tan \alpha} - P_w$$

Let $\alpha = 45.466^\circ$:

$$W = \frac{24.604}{0.766400} + \frac{0.25}{1.016400} = 32.3493 \text{ k/ft}$$

$$U = \frac{3.125}{0.712834} = 4.3839 \text{ k/ft}$$

$$P_{EE} = \frac{32.3493(1.016400 - 0.383864) + 4.3839(0.383864)/0.701332}{1 + 0.383864(1.016400)}$$

$$- 3.125 = 13.3203 \text{ k/ft}$$

Let $\alpha = 44.466^\circ$:

$$W = \frac{24.604}{0.731531} + \frac{0.25}{0.981531} = 33.8883 \text{ k/ft}$$

$$U = \frac{3.125}{0.700486} = 4.4612 \text{ k/ft}$$

$$P_{EE} = \frac{33.8883(0.981531 - 0.383864) + 4.4612(0.383864)/0.713666}{1 + 0.383864(0.981531)}$$

$$- 3.125 = 13.3290 \text{ k/ft} > 13.3203 \text{ k/ft}$$

Let $\alpha = 43.466^\circ$:

$$W = \frac{24.604}{0.697837} + \frac{0.25}{0.947837} = 35.5213 \text{ k/ft}$$

$$U = \frac{3.125}{0.687924} = 4.5427 \text{ k/ft}$$

$$P_{EE} = \frac{35.5213(0.947837 - 0.383864) + 4.5427(0.383864)/0.725783}{1 + 0.383864(0.947837)}$$

$$- 3.125 = 13.3254 \text{ k/ft} < 13.3290 \text{ k/ft}$$

α critical = 44.466° instead of 45.466°. $P_{\max} = P_{EE} = 13.33 \text{ k/ft}$ instead of 13.32 k/ft

d. Conclusion. These small differences in α and P_{EE} are due to the fact that the effect of water on the critical slip-plane angle is neglected in Equations 3-26 and 3-27. These differences are well within the permissible range of error required for soil pressure calculations. It can be concluded that for a cohesionless soil without a finite surcharge (V), it is not necessary to consider the effect of water when calculating the value of α .

- M-4. EXAMPLE 4. Find lateral soil force (P_{EE}) that will act on Surface ABC. Show the effect of water on slip-plane angle (α), and earth force.

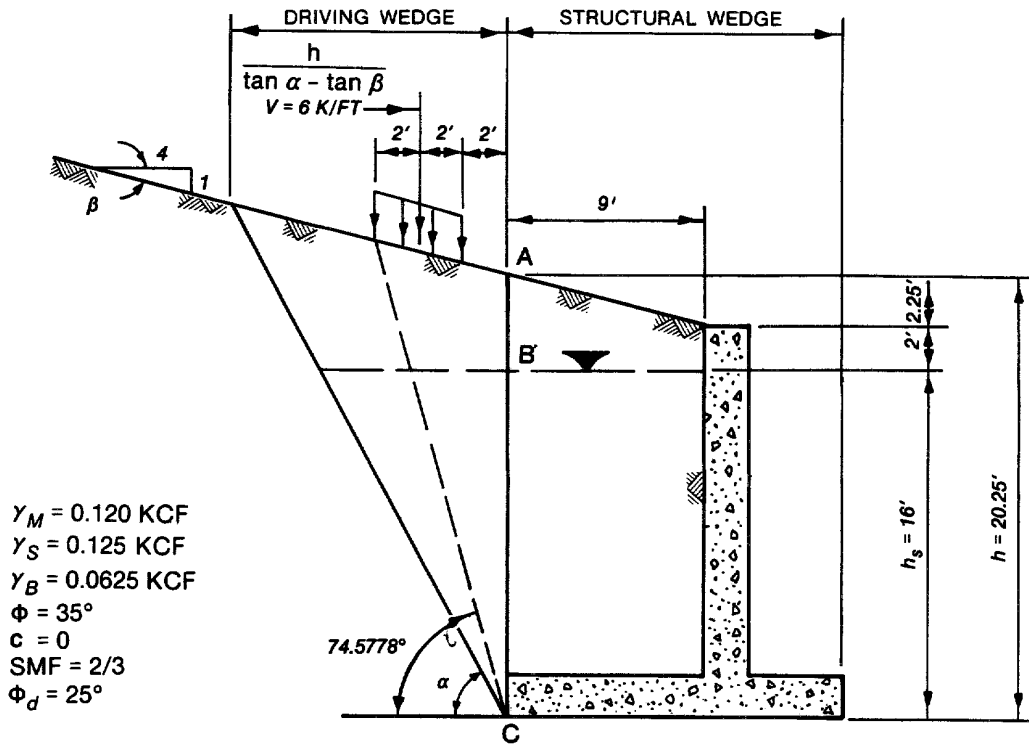

- a. Calculate α --neglecting effect of water. From Equation 3-30 (omitting the c term)

$$A = \tan \phi_d - \frac{2V(1 + \tan^2 \phi_d)}{\gamma_m h^2} = 0.466308 - \frac{2(6)(1.217443)}{0.12(20.25)^2}$$

$$A = 0.169416$$

From Equation 3-28 (omitting the c term)

$$c_1 = \frac{2 \tan^2 \phi_d - \frac{4V \tan \beta (1 + \tan^2 \phi_d)}{\gamma_m h^2}}{A}$$

$$= \frac{2(0.466308)^2 - \frac{4(6)(1/4)(1.217443)}{0.12(20.25)^2}}{0.169416}$$

$$c_1 = 1.690751$$

From Equation 3-29 (omitting the c term)

$$c_2 = \frac{\tan \phi_d (1 - \tan \phi_d \tan \beta) - \tan \beta + \frac{2V \tan^2 \beta (1 + \tan^2 \phi_d)}{\gamma_m h^2}}{A}$$

$$c_2 = \frac{0.466308 [(1 - 0.466308(1/4))] - \frac{1}{4} + \frac{2(6)(1/16)(1.217443)}{0.12(20.25)^2}}{0.169416} = 1.065442$$

$$\alpha = \tan^{-1} \left(\frac{c_1 + \sqrt{c_1^2 + 4c_2}}{2} \right) = \underline{\underline{65.354^\circ}} \quad [3-25]$$

b. Calculate α --include effect of water. Use γ_{avg} instead of γ_m , where:

$$\gamma_{avg} = \left[\frac{\gamma_m h^2}{2 (\tan \alpha - \tan \beta)} - \frac{(\gamma_m - \gamma_b) h_s^2}{2 \tan \alpha} \right] + \left[\frac{h^2}{2 (\tan \alpha - \tan \beta)} \right]$$

Let $\alpha = 74.5778^\circ$

$$\gamma_{\text{avg}} = \left[\frac{0.12(20.25)^2}{2(3.374990)} - \frac{0.0575(16)^2}{2(3.624990)} \right] \div \left[\frac{(20.25)^2}{2(3.374990)} \right]$$

$$\gamma_{\text{avg}} = 0.087 \text{ kcf}$$

$$A = 0.466308 - \frac{2(6)(1.217443)}{0.087(20.25)^2} = 0.056802$$

$$c_1 = \frac{2(0.466308)^2 - \frac{4(6)(1/4)(1.217443)}{0.087(20.25)^2}}{0.056802} = 4.051497$$

$$c_2 = \frac{0.466308 \left[1 - 0.466308(1/4) \right] - \frac{1}{4} + \frac{2(6)(1/16)(1.217443)}{0.087(20.25)^2}}{0.056802}$$

$$c_2 = 3.301668$$

$$\alpha = \tan^{-1} \left(\frac{c_1 + \sqrt{c_1^2 + 4c_2}}{2} \right) = \underline{\underline{78.104^\circ}} > 74.5778^\circ$$

Use: $\alpha = 74.5778^\circ$, the entire surcharge will not lie on the top surface of the wedge when the angle is greater.

c. Calculate earth pressure coefficients (see Appendix H). For $\alpha = 65.354^\circ$ (neglecting effect of water):

$$K = \frac{1 + \tan \phi_d \cot \alpha}{1 - \tan \phi_d \tan \alpha}$$

$$K = \frac{1 - 0.466308(0.458807)}{1 + 0.466308(2.179565)} = 0.389841$$

$$K_1 = K \left(\frac{\tan \alpha}{\tan \alpha - \tan \beta} \right)$$

$$K_1 = 0.389841 \left(\frac{2.179565}{1.929565} \right) = 0.44035$$

$$K_b = K \left[1 + \left(\frac{\tan \alpha}{\tan \alpha - \tan \beta} - 1 \right) \left(\frac{\gamma_m}{\gamma_b} \right) \right]$$

$$K_b = 0.389841 \left[1 + \left(\frac{2.179565}{1.929565} - 1 \right) \left(\frac{0.120}{0.0625} \right) \right] = 0.48682$$

$$K_v = K \tan \alpha$$

$$K_v = 0.389841(2.179565) = 0.84968$$

For $\alpha = 74.5778^\circ$ (including effect of water):

$$K = \frac{1 - 0.466308(0.275863)}{1 + 0.466308(3.624990)} = 0.323883$$

$$K_1 = 0.323883 \left(\frac{3.624990}{3.374990} \right) = 0.34787$$

$$K_b = 0.323883 \left[1 + \left(\frac{3.624990}{3.374990} - 1 \right) \left(\frac{0.120}{0.0625} \right) \right] = 0.36995$$

$$K_v = 0.323883(3.624990) = 1.17407$$

d. Calculate lateral soil force (using coefficients). For $\alpha = 65.354^\circ$:

$$P_y = (1/2)K_1\gamma_m(h - h_s)^2 + (1/2)(h_s) \left[2K_1\gamma_m(h - h_s) + K_b\gamma_b h_s \right]$$

$$P_y = (1/2)(0.44035)(0.12)(4.25)^2 + (1/2)(16) \left[2(0.44035)(0.12)(4.25) \right. \\ \left. + 0.48682(0.0625)(16) \right]$$

$$P_y = 7.965 \text{ k/ft}$$

$$P_v = K_v V = 0.84968(6) = 5.098 \text{ k/ft}$$

$$P_{EE} = 7.965 + 5.098 = \underline{\underline{13.063 \text{ k/ft}}}$$

For $\alpha = 74.5778^\circ$:

$$P_\gamma = (1/2)(0.34787)(0.12)(4.25)^2 + (1/2)(16) \left[2(0.34787)(0.12)(4.25) + 0.36995(0.0625)(16) \right]$$

$$P_\gamma = 6.175 \text{ k/ft}$$

$$P_v = 1.17407(6) = 7.044 \text{ k/ft}$$

$$P_{EE} = 6.175 + 7.044 = \underline{\underline{13.219 \text{ k/ft}}}$$

e. Find lateral soil force by iteration of Equation 3-23. Simplifying Equation 3-23.

$$P_{EE} = \frac{(W + V) (\tan \alpha - \tan \phi_d) + U \tan \phi_d / \cos \alpha}{1 + \tan \phi_d \tan \alpha} - P_w$$

$$W = \frac{\gamma_m h^2}{2 (\tan \alpha - \tan \beta)} + \frac{(\gamma_s - \gamma_m) h_s^2}{2 \tan \alpha}$$

$$W = \frac{0.12(20.25)^2}{2 (\tan \alpha - \tan \beta)} + \frac{(0.005)(16)^2}{2 \tan \alpha} = \frac{24.6038}{\tan \alpha - \tan \beta} + \frac{0.64}{\tan \alpha}$$

$$U = \frac{\gamma_w h_s^2}{2 \sin \alpha} = \frac{0.0625(16)^2}{2 \sin \alpha} = \frac{8}{\sin \alpha}$$

$$P_w = \frac{\gamma_w h^2}{2} = \frac{0.0625(16)^2}{2} = 8.000 \text{ k/ft}$$

Let $\alpha = 73.5778^\circ$

$$W = \frac{24.6038}{3.142854} + \frac{0.64}{3.392854} = 8.0171 \text{ k/ft}$$

$$U = \frac{8.00}{0.959205} = 8.3402 \text{ k/ft} , \quad W + V = 14.0171 \text{ k/ft}$$

$$P_{EE} = \frac{14.0171(3.392854 - 0.466308) + 8.3402(0.466308)/0.282713}{1 + 0.466308(3.392854)}$$

$$- 8.000 = \underline{\underline{13.214 \text{ k/ft}}}$$

Let $\alpha = 74.5778^\circ$

$$W = \frac{24.6038}{3.374990} + \frac{0.64}{3.624990} = 7.4666 \text{ k/ft}$$

$$W + V = 13.4666 \text{ k/ft} , \quad U = \frac{8.00}{0.963992} = 8.2988 \text{ k/ft}$$

$$P_{EE} = \frac{13.4666(3.624990 - 0.466308) + 8.2988(0.466308)/0.265930}{1 + 0.466308(3.624990)}$$

$$- 8.000 = \underline{\underline{13.220 \text{ k/ft}}} > 13.214$$

Let $\alpha = 75.5778^\circ$ (all of V does not lie on top of wedge)

$$\frac{h}{\tan \alpha - \tan \beta} = \frac{20.25}{3.638487} = 5.5655 \text{ ft}$$

$$v = \left(\frac{5.5655 - 2}{4} \right) 6 \text{ k/ft} = 5.3483 \text{ k/ft}$$

$$W = \frac{24.6038}{3.638487} + \frac{0.64}{3.888487} = 6.9267 \text{ k/ft}$$

$$W + V = 12.2750 \text{ k/ft} , \quad U = 8/0.96847 = 8.2603$$

$$P_{EE} = \frac{12.275(3.888487 - 0.466308) + 8.2603(0.466308)/0.249065}{1 + 0.466308(3.888487)}$$

$$- 8.000 = \underline{\underline{12.429 \text{ k/ft}}} < 13.220$$

$$P_{EE} = \underline{\underline{13.220 \text{ k/ft}}} \text{ (agrees with coefficient solution where } \alpha \text{ is found considering the effect of water)}$$

f. Determine line of action for lateral force due to V using the approximate method of Figure 3-29. Find α' , the slip-plane angle without surcharge:

Use $SMF = 1.00$ in Equations 3-26 and 3-27.

$$c_1 = 2 \tan \phi = 2(0.700208) = 1.400416$$

$$c_2 = 1 - \tan \phi \tan \beta - \frac{\tan \beta}{\tan \phi}$$

$$c_2 = 1 - 0.700208(1/4) - \frac{(1/4)}{0.700208} = 0.467911$$

From Equation 3-25

$$\alpha' = \tan^{-1} \left(\frac{c_1 + \sqrt{c_1^2 + 4c_2}}{2} \right) = 59.22^\circ$$

The location of P_V is determined in the following figure.

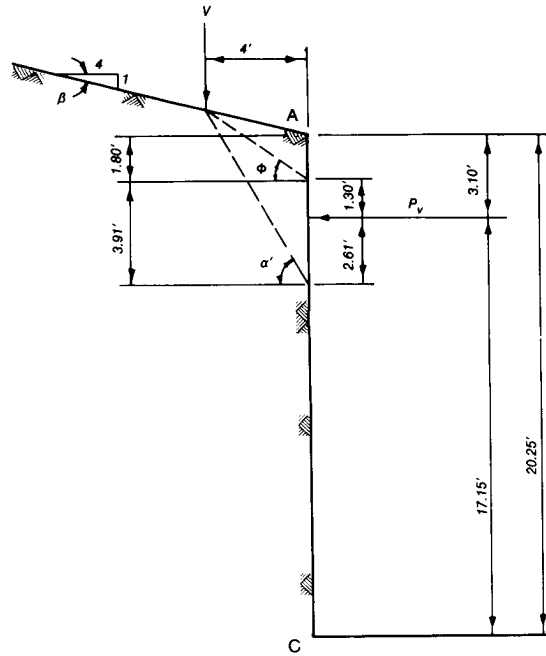

g. Pressure distribution and line of action of earth force P_{EE} for $\alpha = 65.354^\circ$. The pressure distribution and line of action of earth force P_{EE} for $\alpha = 65.354^\circ$ is shown on the following page. A pressure distribution must be assumed for the lateral force due to V since only the location of the resultant force is known. The pressure distribution will be defined by an isosceles triangle with the apex located at the point of application of the resultant force due to V . See example 10 of this appendix for the computation of the lateral force due to a surcharge by the elastic method.

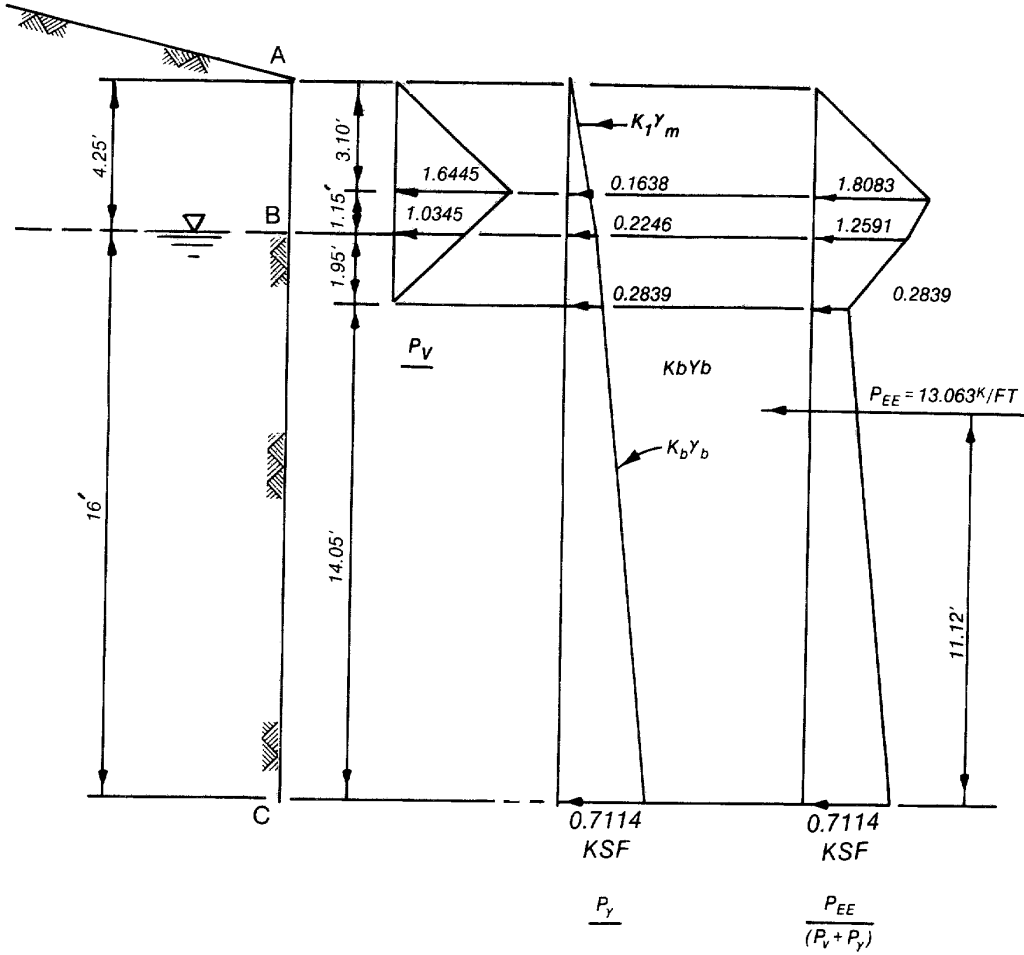

h. Pressure distribution and line of action of earth force P_{EE} for $\alpha = 74.5778^\circ$. The pressure distribution and line of action of earth force P_{EE} for $\alpha = 74.5778^\circ$ is shown on the following page:

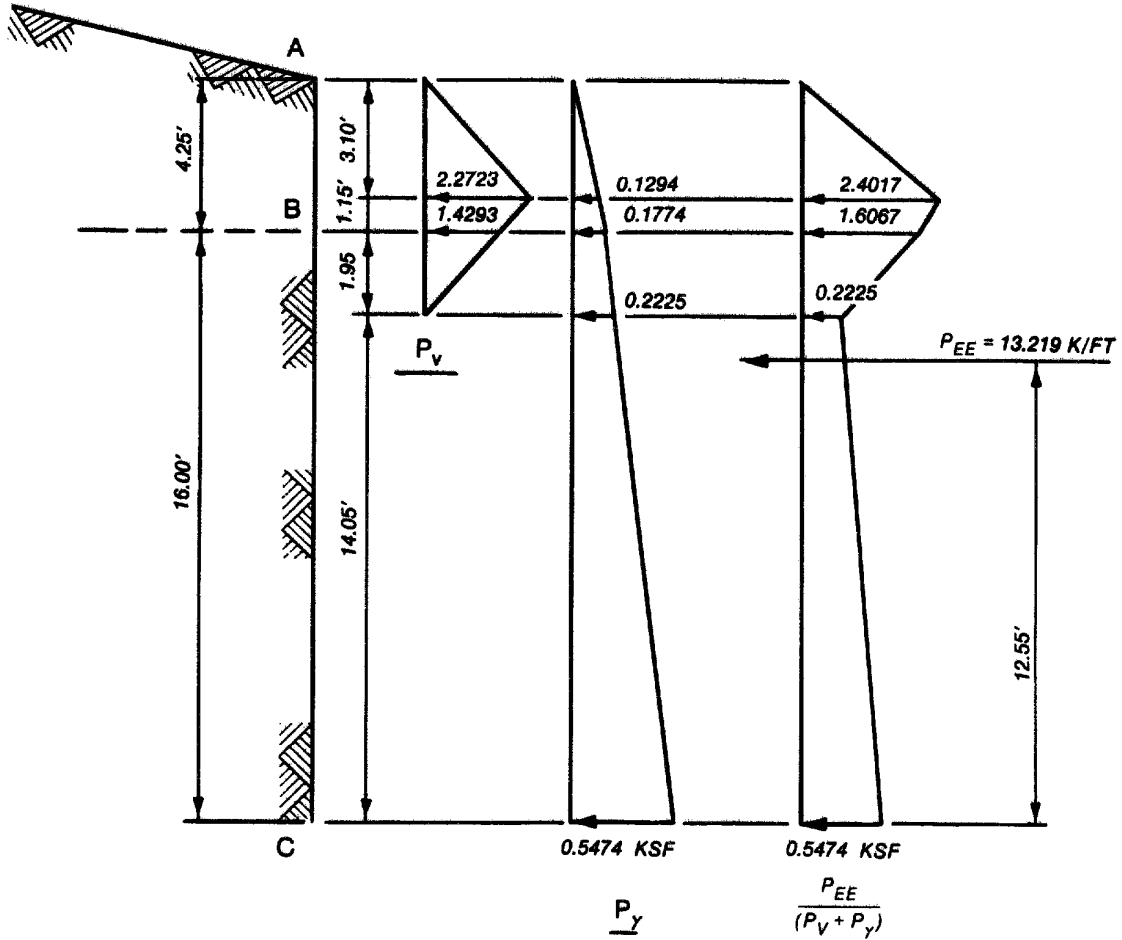

i. Conclusion. For a cohesionless soil when calculating α from Equations 3-28, 3-29 and 3-30, the unit weight of soil (γ) in the strip surcharge (V) term should be the average effective unit weight (γ_{avg}). γ_{avg} should be calculated using the moist unit weight above the water table and the buoyant unit weight below the water table.

M-5. EXAMPLE 5. Find lateral earth force acting on Surface ABC. Use moist unit weight of soil to calculate α . Check solution by iteration of Equation 3-23.

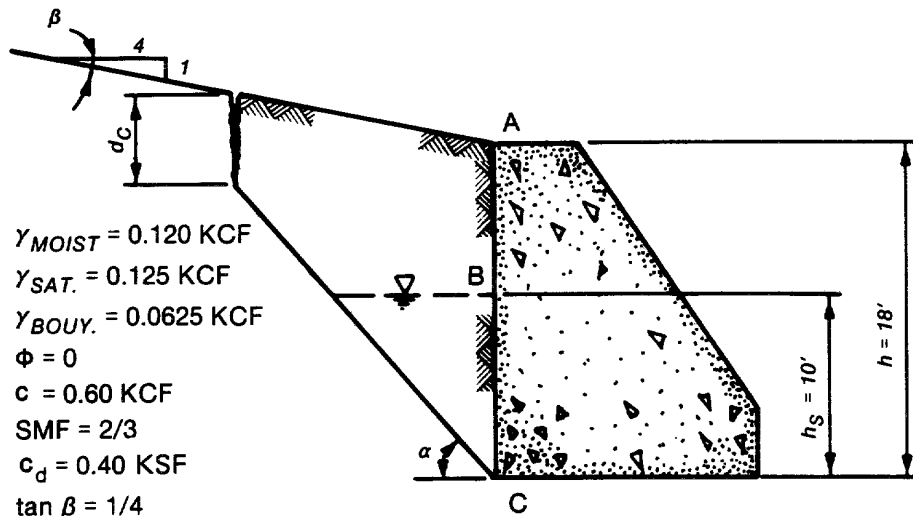

a. Calculate slip-plane angle α . Estimate $\alpha = 40^\circ$:

Using Equation I-2 with $\phi = 0$ yields

$$d_c = \frac{c_d / \gamma_m}{\sin \alpha \cos \alpha} = \frac{0.4 / 0.12}{0.642788(0.766044)} = 6.77 \text{ ft (Appendix I)}$$

From Equation 3-30

$$A = \frac{2c_d}{\gamma_m (h + d_c)} = \frac{2(0.4)}{0.12(24.77)} = 0.269143$$

From Equation 3-28

$$c_1 = \frac{\frac{4c_d \tan \beta}{\gamma_m (h + d_c)}}{A} = \frac{\frac{4(0.4)(1/4)}{0.12(24.77)}}{0.269143} = 0.50$$

From Equation 3-29

$$c_2 = \frac{-\tan \beta + \frac{2c_d}{\gamma_m(h + d_c)}}{A} = \frac{-\frac{1}{4} + \frac{2(0.4)}{0.12(24.77)}}{0.269143} = 0.071125$$

From Equation 3-25

$$\alpha = \tan^{-1} \left(\frac{c_1 + \sqrt{c_1^2 + 4c_2}}{2} \right) = 31.61^\circ \neq 40^\circ$$

Let $\alpha = 31.61^\circ$:

$$d_c = \frac{0.4/0.12}{0.524135(0.851635)} = 7.47 \text{ ft}$$

$$A = \frac{2(0.4)}{0.12(25.47)} = 0.261746$$

$$c_1 = \frac{\frac{4(0.4)(1/4)}{0.12(25.47)}}{0.261746} = 0.50$$

$$c_2 = \frac{-\frac{1}{4} + \frac{2(0.4)}{0.12(25.47)}}{0.261746} = 0.044875$$

$$\alpha = \tan^{-1} \left(\frac{c_1 + \sqrt{c_1^2 + 4c_2}}{2} \right) = 30.01^\circ \neq 31.61^\circ$$

Let $\alpha = 30^\circ$:

$$d_c = \frac{0.4/0.12}{0.5(0.866025)} = 7.70 \text{ ft}$$

$$A = \frac{2(0.4)}{0.12(25.70)} = 0.259403$$

$$c_1 = 0.50, \quad c_2 = \frac{-\frac{1}{4} + 0.259403}{0.259403} = 0.036249$$

$$\alpha = \tan^{-1} \left(\frac{c_1 + \sqrt{c_1^2 + 4c_2}}{2} \right) = 29.43^\circ \neq 30^\circ$$

Let $\alpha = 29^\circ$:

$$d_c = \frac{0.4/0.12}{0.484810(0.874620)} = 7.86 \text{ ft}$$

$$A = \frac{2(0.4)}{0.12(25.86)} = 0.257798$$

$$c_1 = 0.5, \quad c_2 = \frac{-\frac{1}{4} + 0.257798}{0.257798} = 0.030248$$

$$\alpha = \tan^{-1} \left(\frac{c_1 + \sqrt{c_1^2 + 4c_2}}{2} \right) = 29.01^\circ$$

$$\underline{\alpha = 29^\circ} \text{ (nearest degree), } \underline{d_c = 7.86 \text{ ft}}$$

b. Earth pressure coefficients and earth force for $\alpha = 29^\circ$ (see Appendix H).

$$K = \frac{1 - \tan \phi_d \cot \alpha}{1 + \tan \phi_d \tan \alpha} = 1.00$$

$$K_1 = K \left(\frac{\tan \alpha}{\tan \alpha - \tan \beta} \right) = 1.00 \left(\frac{0.554309}{0.304309} \right) = 1.8215$$

$$K_b = K \left[1 + \left(\frac{\tan \alpha}{\tan \alpha - \tan \beta} - 1 \right) \left(\frac{\gamma_m}{\gamma_b} \right) \right]$$

$$K_b = 1.00 \left[1 + \left(\frac{0.554309}{0.304309} - 1 \right) \frac{0.120}{0.0625} \right] = 2.5773$$

$$P_{EE} = (1/2)K_1\gamma_m(h - h_s - d_c)^2 + (1/2)h_s \left[2K_1\gamma_m(h - h_s - d_c) + K_b\gamma_b h_s \right]$$

$$h = 18 \text{ ft}, \quad h_s = 10 \text{ ft}, \quad d_c = 7.86 \text{ ft}$$

$$P_{EE} = (1/2)(1.8215)(0.12)(0.14)^2 + (1/2)(10) \left[2(1.8215)(0.12)(0.14) + 2.5773(0.0625)(10) \right] = \underline{\underline{8.362 \text{ k/ft}}}$$

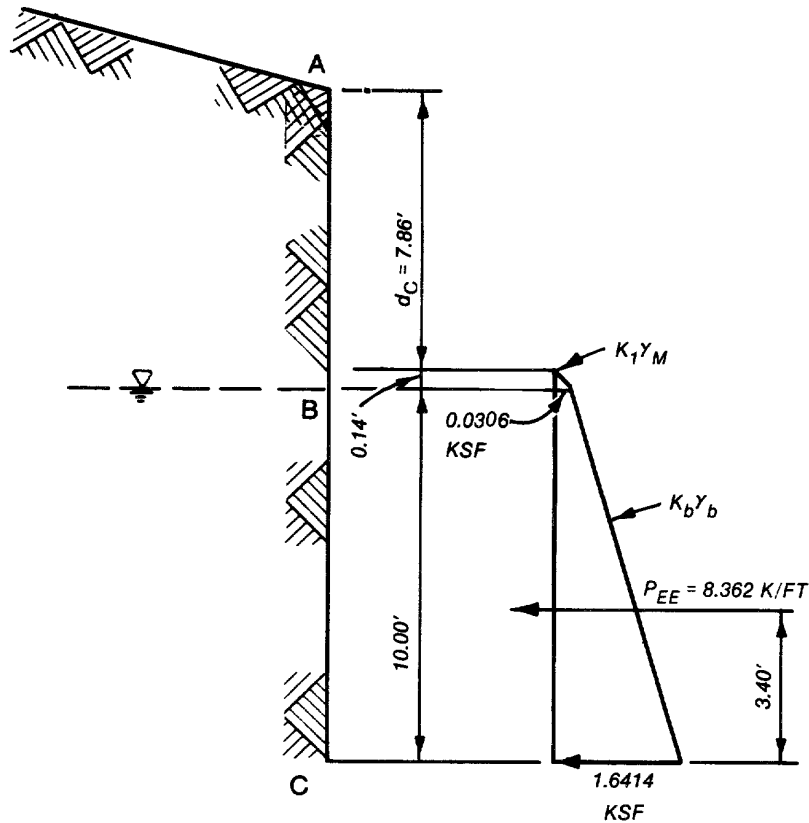

c. Check solution by iteration of Equation 3-23.

$$W = \frac{\gamma_m (h^2 - d_c^2)}{2(\tan \alpha - \tan \beta)} + \frac{(\gamma_s - \gamma_m) h_s^2}{2 \tan \alpha}$$

$$W = \frac{0.06(h^2 - d_c^2)}{\tan \alpha - \tan \beta} + \frac{0.25}{\tan \alpha}$$

$$d_c = \frac{c_d / \gamma_m}{\sin \alpha \cos \alpha} = \frac{3.3333}{\sin \alpha \cos \alpha}$$

$$L = \frac{h - d_c}{\cos \alpha (\tan \alpha - \tan \beta)}, \quad P_w = \frac{1}{2} \gamma_w h_s^2 = 3.125 \text{ k/ft}$$

From Equation 3-23

$$P_{EE} = W \tan \alpha - c_d L / \cos \alpha - P_w$$

Let $\alpha = 28^\circ$:

$$d_c = \frac{3.3333}{0.469472(0.882948)} = 8.04 \text{ ft}, \quad h^2 - d_c^2 = 259.3584$$

$$L = \frac{9.96}{0.882948(0.281709)} = 40.0427 \text{ ft}$$

$$W = \frac{0.06(259.3584)}{0.281709} + \frac{0.25}{0.531709} = 55.7098 \text{ k/ft}$$

$$P_{EE} = 55.7098(0.531709) - 0.4(40.0427)/0.882948 - 3.125$$

$$P_{EE} = 8.356 \text{ k/ft}$$

Let $\alpha = 29^\circ$:

$$d_c = \frac{3.3333}{0.484810(0.874620)} = 7.86 \text{ ft}$$

$$h^2 - d_c^2 = 262.2204, \quad L = \frac{10.14}{0.87462(0.304309)} = 38.0981 \text{ ft}$$

$$W = \frac{0.06(262.2204)}{0.304309} + \frac{0.25}{0.554309} = 52.1525 \text{ k/ft}$$

$$P_{EE} = 52.1525(0.554309) - 0.4(38.0981)/0.87462 - 3.125$$

$$P_{EE} = \underline{\underline{8.360 \text{ k/ft}}} > 8.356$$

Let $\alpha = 30^\circ$:

$$d_c = \frac{3.3333}{0.5(0.866025)} = 7.70 \text{ ft}, \quad h^2 - d_c^2 = 264.71$$

$$L = \frac{10.30}{0.866025(0.327350)} = 36.3324 \text{ ft}$$

$$W = \frac{0.06(264.71)}{0.327350} + \frac{0.25}{0.57735} = 48.9517 \text{ k/ft}$$

$$P_{EE} = 48.9517(0.57735) - 0.4(36.3324)/0.866025 - 3.125$$

$$P_{EE} = 8.356 \text{ k/ft} < 8.360$$

Iteration of Equation 3-23 shows that:

$$\underline{\underline{\alpha_{crit} = 29^\circ}} \text{ (to nearest degree), } \underline{\underline{P_{EE} = 8.360 \text{ k/ft}}}$$

which agrees with the pressure coefficient solution.

d. Conclusion. Use the moist unit weight of soil (γ_m) in the cohesion terms of Equations 3-28, 3-29, and 3-24; even if the soil is partially saturated.

$$V_{\alpha} = -\frac{\gamma_1 h_2^2 (\tan \beta_1 - \tan \beta_2)}{2 (\tan \alpha_2 - \tan \beta_2)^2} = \frac{-0.12(10)^2 \left(\frac{1}{6}\right)}{2 \left(\tan \alpha_2 - \frac{1}{6}\right)^2} = \frac{-1}{\left(\tan \alpha_2 - \frac{1}{6}\right)^2}$$

First trial: $\alpha_2 = 39^\circ$, $\gamma' = 0.5042$, $V_{\alpha} = -2.4178$

From Equation G-27

$$A' = \tan \phi_{d2} - \frac{2V_{\alpha}(1 + \tan^2 \phi_{d2})}{\gamma' h_2^2}$$

$$A' = 0.242665 - \frac{2(-2.4178)(1.058886)}{0.5042(10)^2} = 0.344219$$

From Equation G-28

$$c'_1 = \frac{2 \tan^2 \phi_{d2} - \frac{4V_{\alpha} \tan \beta_2 (1 + \tan^2 \phi_{d2})}{\gamma' h_2^2}}{A'}$$

$$c'_1 = \frac{2(0.242665)^2 - \frac{4(-2.4178)\left(\frac{1}{6}\right)(1.058886)}{0.5042(10)^2}}{0.344219} = 0.440486$$

From Equation G-29

$$c'_2 = \frac{\tan \phi_{d2} (1 - \tan \phi_{d2} \tan \beta_2) - \tan \beta_2 + \frac{2V_{\alpha} \tan^2 \beta_2 (1 + \tan^2 \phi_{d2})}{\gamma' h_2^2}}{A'}$$

$$c_2' = \frac{0.242665 \left(1 - 0.242665 \times \frac{1}{6}\right) - \frac{1}{6} + \frac{2(-2.4178)\left(\frac{1}{36}\right)(1.058886)}{0.5042(10)^2}}{0.344219}$$

$$c_2' = 0.184077$$

$$\alpha_2 = \tan^{-1} \left(\frac{c_1' + \sqrt{c_1'^2 + 4c_2'}}{2} \right) \quad [G-30]$$

$$\alpha_2 = 35.1^\circ \neq 39^\circ$$

Second trial: $\alpha_2 = 33^\circ$, $\gamma' = 0.5249$, $V_\alpha = -4.2911$

$$A' = 0.242665 - \frac{0.021178(-4.2911)}{0.5249} = 0.415797$$

$$c_1' = \frac{0.117773 - \frac{0.007059(-4.2911)}{0.5249}}{0.415797} = 0.422035$$

$$c_2' = \frac{0.066814 + \frac{0.000588(-4.2911)}{0.5249}}{0.415797} = 0.149128$$

$$\underline{\underline{\alpha_2 = 33^\circ}}$$

b. Calculate α_1 .

$$c_1 = 2 \tan \phi_{d1} = 2(0.466308) = 0.932616 \quad [3-26]$$

$$c_2 = 1 - \tan \phi_{d1} \tan \beta - \frac{\tan \beta}{\tan \phi_{d1}} \quad [3-27]$$

$$c_2 = 1 - 0.466308(1/3) - \frac{(1/3)}{0.466308} = 0.129729$$

$$\alpha_1 = \underline{\underline{46.547^\circ}}$$

c. Calculate lateral earth pressure coefficients (see Appendix H).

Wedge 1:

$$K = \frac{1 - 0.466308(0.947407)}{1 + 0.466308(1.055513)} = 0.374091$$

$$K_1 = 0.374091 \left(\frac{1.055513}{0.722180} \right) = 0.5468$$

Wedge 2:

$$K = \frac{1 - 0.242665(1.539865)}{1 + 0.242665(0.649408)} = 0.541063$$

$$K_1 = 0.541063 \left(\frac{0.649408}{0.482741} \right) = 0.7279$$

$$K_v = 0.541063(0.649408) = 0.3514$$

d. Calculate lateral earth forces and pressures.

Wedge 1:

$$h = h_{AB} = h_1 + \frac{h_2 (\tan \beta_1 - \tan \beta_2)}{(\tan \alpha_2 - \tan \beta_2)}$$

$$h_{AB} = 13 + \frac{(10) \left(\frac{1}{3} - \frac{1}{6} \right)}{0.649408 - 0.166667} = 16.452 \text{ ft}$$

$$P_{EE1} = \frac{1}{2} K_1 \gamma_1 h^2$$

$$P_{EE1} = \frac{1}{2} (0.5468) (0.12) (16.452)^2 = \underline{\underline{8.88 \text{ k/ft}}}$$

$$P_{HB} = K_1 \gamma_1 h_{AB} = 0.5468(0.12)(16.452) = 1.0795$$

Wedge 2:

Treat weight of ABCD as a strip surcharge on Surface BD.

$$V = \frac{1}{2} (h_1 + h_{AB}) (\overline{AZ}) (\gamma_1)$$

$$V = \frac{1}{2} (13 + 16.452)(20.715)(0.12) = 36.606 \text{ k/ft}$$

$$P_{\gamma} = \frac{1}{2} K_1 \gamma_2 h_2^2$$

$$P_{\gamma} = \frac{1}{2} (0.7279)(0.13)(10)^2 = 4.73 \text{ k/ft}$$

$$P_V = K_V V$$

$$P_V = 0.3514(36.606) = 12.86 \text{ k/ft}$$

$$P_{EE2} = P_{\gamma} + P_V = 4.73 + 12.86 = \underline{\underline{17.59 \text{ k/ft}}}$$

$$P_{VD} = \gamma_1 h_1$$

$$P_{VD} = 0.12(13) = 1.56 \text{ ksf} = \text{vertical pressure at D}$$

$$P_{HD} = K_1 P_{VD}$$

$$P_{HD} = 0.7279 P_{VD} = 1.1355 \text{ ksf} = \text{horizontal pressure at D}$$

$$\frac{1}{2} (P_{HD} + P_{HE}) h_2 = P_{EE2}$$

$$P_{HE} = \frac{2P_{EE2}}{h_2} - P_{HD} = \text{horizontal pressure at E}$$

$$P_{HE} = \frac{2(17.59)}{10} - 1.1355 = 2.3825 \text{ ksf}$$

Pressure distributions on Surfaces AB and DE

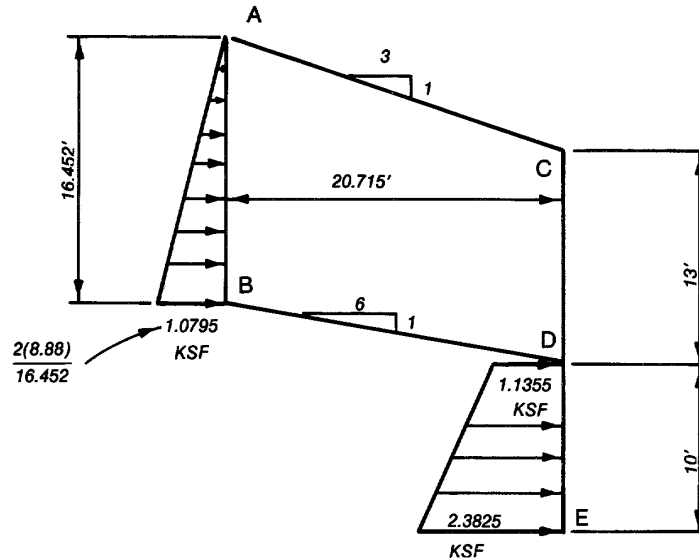

e. Earth pressure on Surfaces CD and DE. The earth force on AB may be transferred to Surface CD by assuming that no shear resistance is developed on Surface BD. Then to obtain moment equilibrium for Block ABCD, a vertical shear force must be developed on Surfaces AB and CD. The shear force will be:

$$V_{AB} = -V_{CD} = P_{EE1} \left(\frac{\tan \beta_1 + \tan \beta_2}{3} \right)$$

A free body of Block ABCD is shown below.

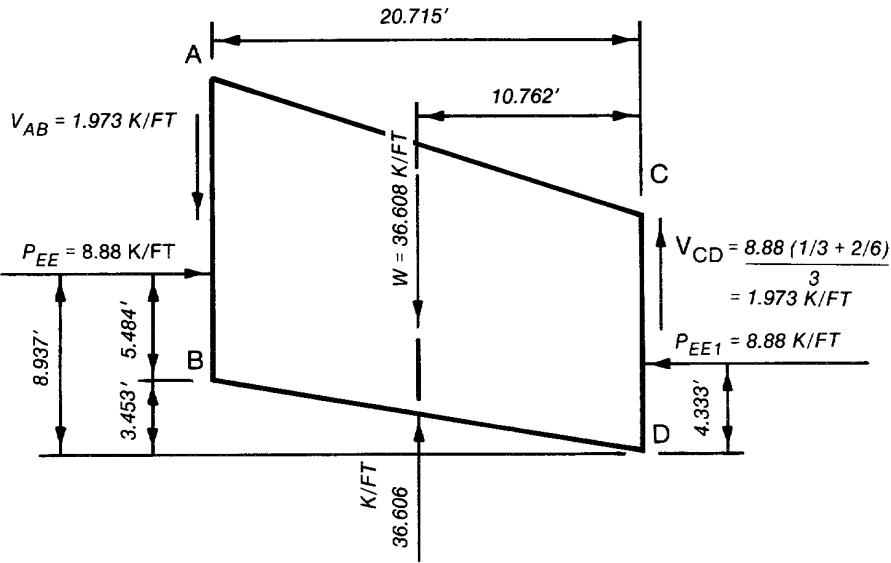

$$\sum M_D = 0$$

$$\sum M_D = 8.88(8.937 - 4.333) - 1.973(20.715) = 0.013 \approx 0$$

The pressure distribution on Surfaces CD and DE is shown below.

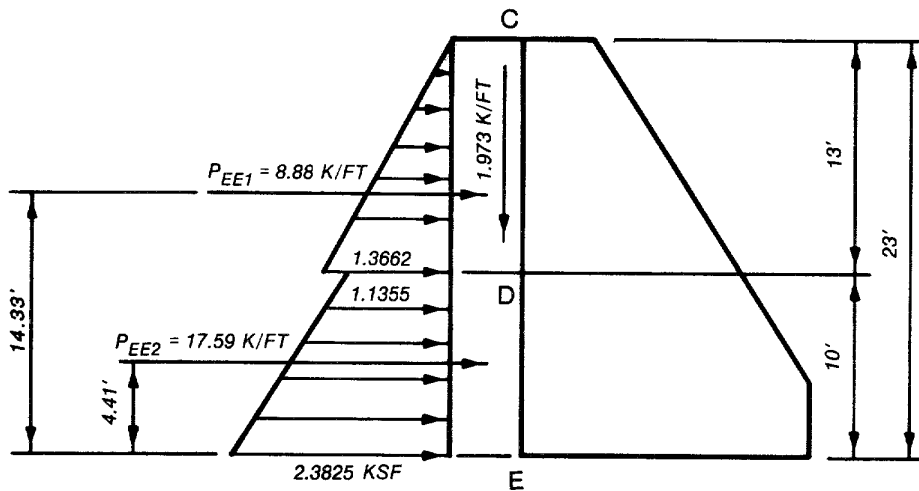

M-7. EXAMPLE 7. Find the lateral earth force and pressure distribution on Surfaces FG and HI when: $\phi = 35^\circ$, $c = 0$, $\gamma = 0.12$ kcf, and $SMF = 2/3$.

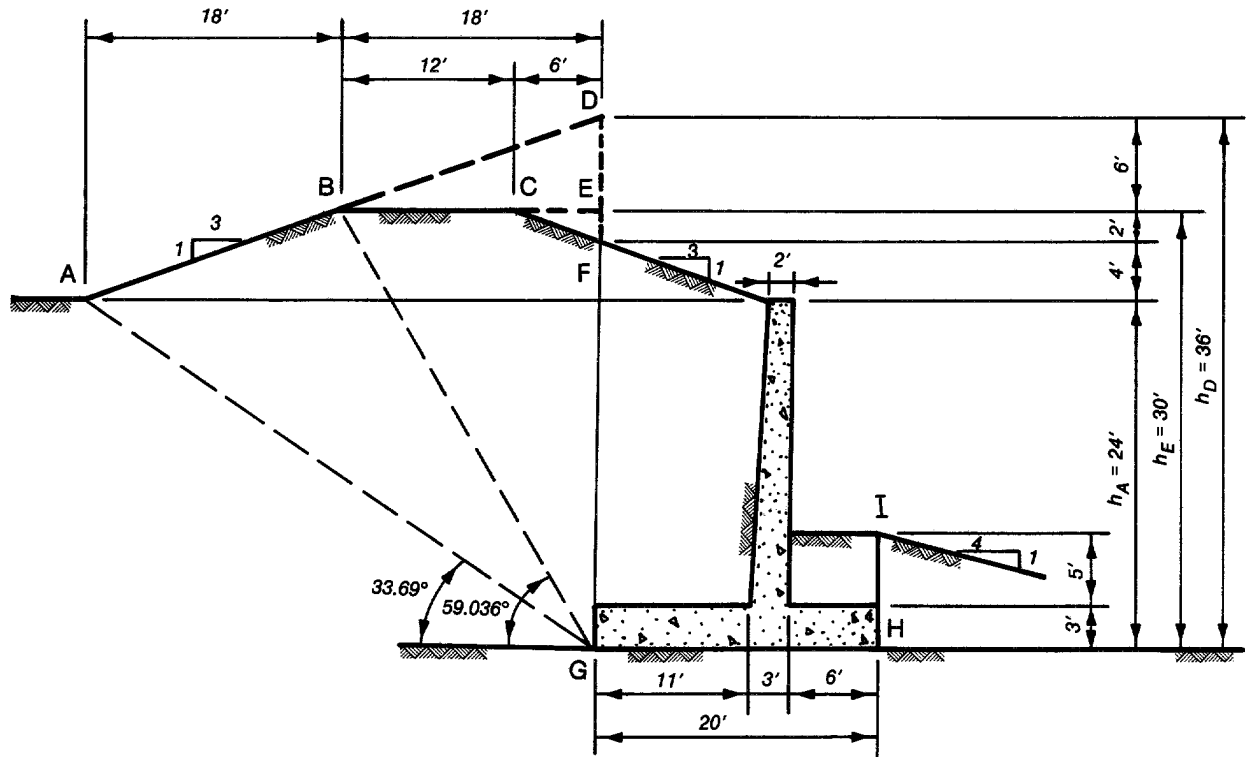

a. Driving side:

(1) Assume that the critical slip plane intersects Surface BC. $\beta = 0$, $h = h_E = 30$ ft. The weight of the triangular area CEF will be taken as a negative strip surcharge. $V = -(1/2)(0.12)(6)(2) = -0.72$ k/ft

$$\phi_d = \tan^{-1} \left(\frac{2}{3} \tan 35^\circ \right) = 25^\circ, \tan \phi_d = 0.466308$$

From Equation 3-30

$$A = \tan \phi_d - \frac{2V(1 + \tan^2 \phi_d)}{\gamma h^2}$$

$$A = 0.466308 - \frac{2(-0.72)(1.217443)}{0.12(30)^2} = 0.482541$$

From Equation 3-28

$$c_1 = \frac{2 \tan^2 \phi_d}{A}$$

$$c_1 = \frac{2(0.466308)^2}{0.482541} = 0.901242$$

From Equation 3-29

$$c_2 = \frac{\tan \phi_d}{A}$$

$$c_2 = \frac{0.466308}{0.482541} = 0.966359$$

$$\alpha' = \tan^{-1} \left(\frac{c_1 + \sqrt{c_1^2 + 4c_2}}{2} \right) = 56.866^\circ < 59.036^\circ$$

This shows that the critical slip plane does not intersect Surface BC.

(2) Assume that critical slip plane intersects Surface AB. $\tan \beta = -(1/3)$, $h = h_D = 36$ ft. The weights of areas BDE and CEF will be taken as a negative strip surcharge.

$$V = \frac{1}{2} (0.12) (18) (6) - \frac{1}{2} (0.12) (6) (2) = -7.2 \text{ k/ft}$$

From Equation 3-30

$$A = 0.466308 - \frac{2(-7.2)(1.217443)}{0.12(36)^2} = 0.579034$$

From Equation 3-28

$$c_1 = \frac{2(0.466308)^2 - \frac{4(-7.2)\left(-\frac{1}{3}\right)(1.217443)}{0.12(36)^2}}{0.579034} = 0.621268$$

From Equation 3-29

$$c_2 = \frac{0.466308 \left[1 - 0.466308 \left(-\frac{1}{3}\right) \right] - \left(-\frac{1}{3}\right) + \frac{2(-7.2)\left(\frac{1}{9}\right)(1.217443)}{0.12(36)^2}}{0.579034}$$

$$c_2 = 1.484537$$

$$\alpha = \tan^{-1} \left(\frac{c_1 + \sqrt{c_1^2 + 4c_2}}{2} \right) = \underline{\underline{57.473^\circ}}$$

$$33.69^\circ < \alpha < 59.036^\circ$$

This shows that critical slip plane does intersect Surface AB.

(3) Calculate the pressure coefficients (see Appendix H).

$$K = \frac{1 - \tan \phi_d \cot \alpha}{1 + \tan \phi_d \tan \alpha} = \frac{1 - 0.466308(0.637733)}{1 + 0.466308(1.568054)} = 0.405858$$

$$K_1 = K \left(\frac{\tan \alpha}{\tan \alpha - \tan \beta} \right) = 0.405858 \left(\frac{1.568054}{1.901387} \right) = 0.334707$$

$$K_v = K \tan \alpha = 0.405858(1.568054) = 0.636407$$

$$P_\gamma = \frac{1}{2} K_1 \gamma h_D^2 = \frac{1}{2} (0.334707)(0.12)(36)^2 = 26.027 \text{ k/ft}$$

$$P_v = K_v V = 0.636407(-7.2) = -4.582 \text{ k/ft}$$

$$P_{EE} = P_\gamma + P_v = 26.027 - 4.582 = \underline{\underline{21.445 \text{ k/ft}}}$$

(4) The net horizontal pressure at point F must be equal to zero, the negative pressure due to P_v cancels the positive pressure due to P_γ .

$$p_{\gamma F} = 0.334707(0.12)(8) = 0.3213 \text{ ksf}, \quad p_{vF} = -0.3213 \text{ ksf}$$

$$h_v \text{ (distribution length for } P_v) = \frac{2P_v}{P_{vF}} = \frac{2(-4.582)}{-0.3213} = 28.52 \text{ ft}$$

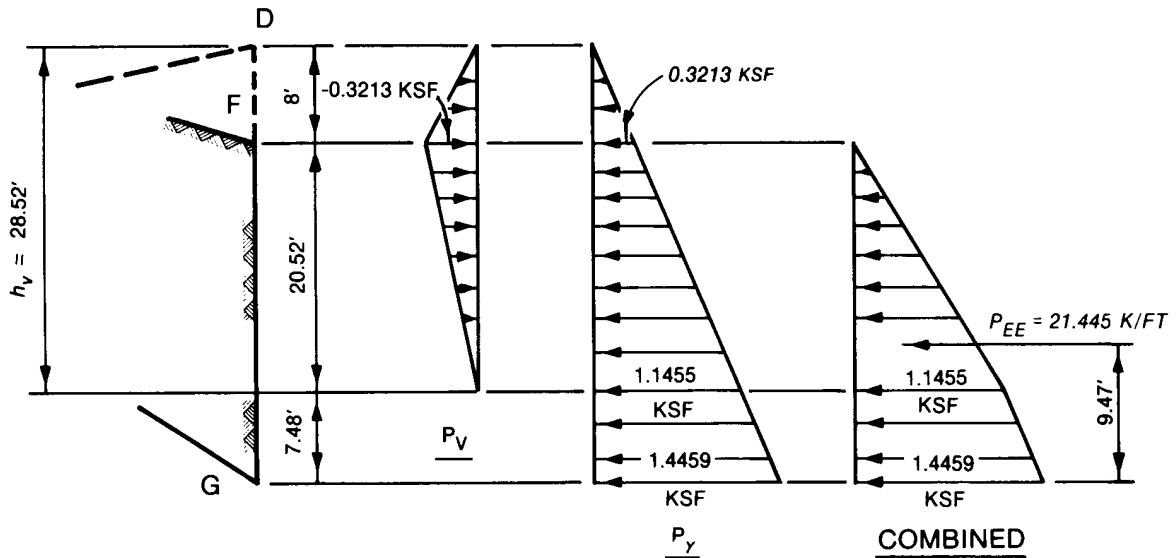

b. Resisting side:

(1) Calculate the critical slip plane angle α .

$$\tan \beta = -\frac{1}{4}, \quad \tan \phi_d = 0.466308$$

From Equation 3-38

$$A = 0.466308$$

From Equation 3-36

$$c_1 = \frac{2 \tan^2 \phi_d}{A}$$

$$c_1 = \frac{2(0.466308)^2}{0.466308} = 0.932616$$

From Equation 3-37

$$c_2 = \frac{\tan \phi_d (1 + \tan \phi_d \tan \beta) + \tan \beta}{A}$$

$$c_2 = \frac{0.466308 \left[1 + 0.466308 \left(-\frac{1}{4} \right) \right] + \left(-\frac{1}{4} \right)}{0.466308} = 0.347297$$

$$\alpha = \tan^{-1} \left(\frac{-c_1 + \sqrt{c_1^2 + 4c_2}}{2} \right) = 15.917^\circ \quad [3-35]$$

(2) Calculate the pressure coefficients (see Appendix H) and pressure distribution.

$$K = \frac{1 + \tan \phi_d \cot \alpha}{1 - \tan \phi_d \tan \alpha} = \frac{1 + 0.466308(3.506578)}{1 - 0.466308(0.285178)} = 3.039316$$

$$K_1 = K \left(\frac{\tan \alpha}{\tan \alpha - \tan \beta} \right) = 3.039316 \left(\frac{0.285178}{0.535178} \right) = 1.619547$$

$$P_{EE} = \frac{1}{2} K_1 \gamma h^2 = \frac{1}{2} (1.619547) (0.12) (8)^2 = \underline{6.22 \text{ k/ft}}$$

The calculation of the passive force and pressure distribution as performed above is adequate for performing a sliding analysis but should be calculated as described in paragraph 3-8 when performing an overturning or bearing capacity analysis and for design of structural members.

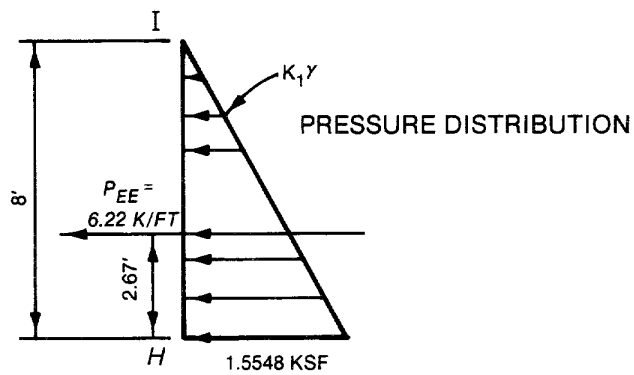

$$A = 0.383864 - \frac{2(-122.88)(1.147352)}{0.12(64)^2} = 0.957540$$

From Equation 3-28

$$c_1 = \frac{2 \tan^2 \phi_d}{A}$$

$$c_1 = \frac{2(0.383864)^2}{0.957540} = 0.307771$$

From Equation 3-29

$$c_2 = \frac{\tan \phi_d}{A}$$

$$c_2 = \frac{0.383864}{0.957540} = 0.400886$$

$$\alpha = \tan^{-1} \left(\frac{c_1 + \sqrt{c_1^2 + 4c_2}}{2} \right) = \underline{\underline{38.851^\circ}}$$

$33.69^\circ < \alpha < 45^\circ$, assumption that slip plane intersects Surface AB is correct.

(2) Calculate the pressure coefficients (see Appendix H)

$$K = \frac{1 - \tan \phi_d \cot \alpha}{1 + \tan \phi_d \tan \alpha} = \frac{1 - 0.383864(1.241485)}{1 + 0.383864(0.805487)} = 0.399816$$

$$K_v = K \tan \alpha = 0.399816(0.805487) = 0.322047$$

$$P_\gamma = \frac{1}{2} K \gamma h^2 = \frac{1}{2} (0.399816)(0.12)(64)^2 = 98.26 \text{ k/ft}$$

$$P_v = K_v V = 0.322047(-122.88) = -39.57 \text{ k/ft}$$

$$P_{EE} = P_\gamma + P_v = 98.26 - 39.57 = \underline{58.69 \text{ k/ft}}$$

(3) The net pressure at point E must be equal to zero. The negative pressure due to P_v cancels the positive pressure due to P_γ .

$$P_{\gamma E} = 0.399816(0.12)(32) = 1.5353 \text{ ksf}$$

$$P_{vE} = -1.5353 \text{ ksf}$$

$$h_v \text{ (distribution length for } P_v) = \frac{2P_v}{P_{vE}} = \frac{2(-39.57)}{-1.5353} = 51.55 \text{ ft}$$

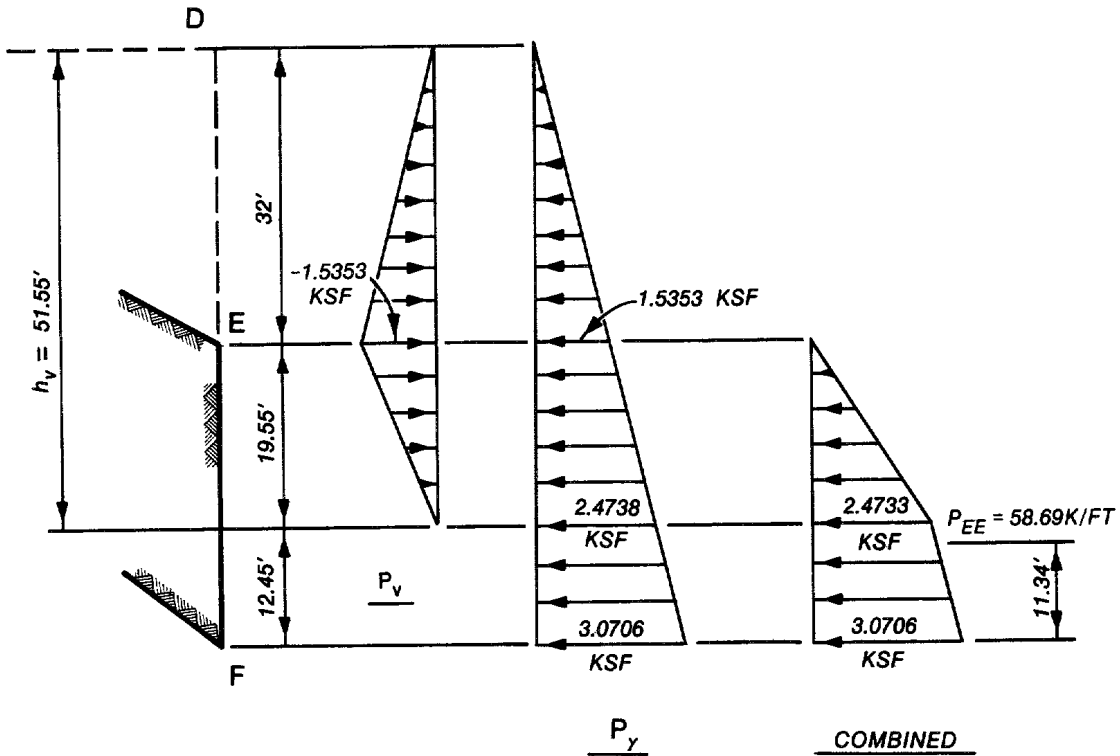

b. $\phi = 0$, $c = 0.6$ ksf, $c_d = 2/3$, $c = 0.4$ ksf.

(1) Assume that the vertical crack extends upward from the critical slip plane to intersect Surface BE.

$$\tan \beta = 0.5 , \quad h = h_E = 32 \text{ ft}$$

From the equations given in Appendix H

$$K_1 = \frac{1 - \tan \phi_d \cot \alpha}{1 + \tan \phi_d \tan \alpha} \cdot \frac{\tan \alpha}{\tan \alpha - \tan \beta} = \frac{\tan \alpha}{\tan \alpha - \tan \beta}$$

$$K_c = \frac{1}{2 \sin \alpha \cos \alpha (1 + \tan \phi_d \tan \alpha)} \cdot \frac{\tan \alpha}{\tan \alpha - \tan \beta}$$

$$K_c = \frac{1}{2 \sin \alpha \cos \alpha} \cdot \frac{\tan \alpha}{\tan \alpha - \tan \beta}$$

From Equation I-2

$$d_c = \frac{2K_c c_d}{K_1 \gamma} = \frac{c_d / \gamma}{\sin \alpha \cos \alpha}$$

$$d_c = \frac{0.4/0.12}{\sin \alpha \cos \alpha} = \frac{3.333 \text{ ft}}{\sin \alpha \cos \alpha}$$

Assume that $\alpha = 45^\circ$, then $d_c = \frac{3.333}{0.5} = 6.667 \text{ ft}$

From Equation 3-30

$$A = \frac{2c_d}{\gamma(h + d_c)}$$

$$A = \frac{2(0.4)}{0.12(38.667)} = 0.172412$$

From Equation 3-28

$$c_1 = \frac{4c_d \tan \beta}{\frac{\gamma(h + d_c)}{A}}$$

$$c_1 = \frac{4(0.4)(0.5)}{0.12(38.667)} = 1.00$$

From Equation 3-29

$$c_2 = \frac{-\tan \beta + \frac{2c_d}{\gamma(h + d_c)}}{A}$$

$$c_2 = \frac{-0.5 + \frac{2(0.4)}{0.12(38.667)}}{0.172412} = -1.900030$$

The term under the radical in Equation 3-25 will be negative. This makes α indeterminate, so the assumption that the crack intersects Surface BE is not correct.

(2) Assume that the vertical crack intersects Surface AB.

$\tan \beta = 0$, $h = h_d = 64$ ft, $V = -122.88$ k/ft (negative weight of area BDE)

Again assume $\alpha = 45^\circ$, $d_c = 6.667$ ft

From Equations 3-28, 3-29, and 3-30

$$A = \frac{2c_d}{\gamma(h + d_c)} - \frac{2V}{\gamma(h^2 - d_c^2)}$$

$$A = \frac{2(0.4)}{0.12(70.667)} - \frac{2(-122.88)}{0.12(4051.55)} = 0.599825$$

$$c_1 = 0, \quad c_2 = \frac{2c_d}{\gamma(h + d_c)} / A = \frac{2(0.4)}{0.12(70.667)} / 0.599825 = 0.157278$$

$$\alpha = \tan^{-1} \left(\frac{c_1 + \sqrt{c_1^2 + 4c_2}}{2} \right) = 21.63^\circ \neq 45^\circ \quad [3-25]$$

Let $\alpha = 21.63^\circ$, $d_c = \frac{3.333}{0.342655} = 9.727 \text{ ft}$

$$A = \frac{2(0.4)}{0.12(73.727)} - \frac{2(-122.88)}{0.12(4001.39)} = 0.602246$$

$$c_1 = 0, \quad c_2 = \frac{2(0.4)}{0.12(73.727)} / 0.602246 = 0.150144$$

$$\alpha = \tan^{-1} \left(\frac{c_1 + \sqrt{c_1^2 + 4c_2}}{2} \right) = 21.18^\circ \neq 21.63^\circ$$

Let $\alpha = 21.18^\circ$, $d_c = \frac{3.333}{0.336893} = 9.893 \text{ ft}$

$$A = \frac{2(0.4)}{0.12(73.893)} - \frac{2(-122.88)}{0.12(3998.13)} = 0.602460$$

$$c_1 = 0, \quad c_2 = \frac{2(0.4)}{0.12(73.893)} / 0.602460 = 0.149754$$

$$\alpha = 21.15^\circ \neq 21.18^\circ$$

$$\text{Let } \alpha = 21.15^\circ, \quad d_c = \frac{3.333}{0.336506} = 9.90 \text{ ft}$$

$$A = \frac{2(0.4)}{0.12(73.90)} - \frac{2(-122.88)}{0.12(3997.99)} = 0.602469$$

$$c_1 = 0, \quad c_2 = \frac{2(0.4)}{0.12(73.90)} / 0.602469 = 0.149737$$

$$\underline{\underline{\alpha = 21.15^\circ}}, \quad \underline{\underline{d_c = 9.90 \text{ ft}}}$$

Check to see if crack intersects Surface AB.

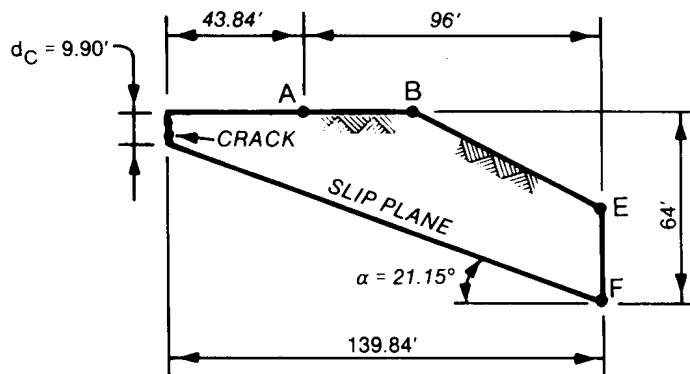

Assumption that crack intersects Surface AB is not correct.

(3) Assume that the crack intersects the sloping surface to the left of point A.

$$\tan \beta = -\frac{1}{3}, \quad h = h_c = 96 \text{ ft}, \quad V = -\frac{1}{2} (0.12) [(64)(32) + (96)(32)]$$

$$V = -307.20 \text{ k/ft (negative weight of areas ACD and BDE)}$$

$$\text{Let } \alpha = 30^\circ, \quad d_c = \frac{3.333}{0.433013} = 7.70 \text{ ft}$$

From Equation 3-30

$$A = \frac{2c_d(1 - \tan \phi \tan \beta)}{\gamma(h + d_c)} - \frac{2V}{\gamma(h^2 - d_c^2)}$$

$$A = \frac{2(0.4)}{0.12(103.70)} - \frac{2(-307.20)}{0.12(9156.71)} = 0.623441$$

From Equation 3-28

$$c_1 = \frac{\frac{4c_d \tan \beta}{\gamma(h + d_c)} - \frac{4V \tan \beta}{\gamma(h^2 - d_c^2)}}{A}$$

$$c_1 = \frac{\frac{4(0.4)\left(-\frac{1}{3}\right)}{0.12(103.70)} - \frac{4(-307.20)\left(-\frac{1}{3}\right)}{0.12(9156.71)}}{0.623441} = -0.666666$$

From Equation 3-29

$$c_2 = \frac{-\tan \beta + \frac{2c_d}{\gamma(h + d_c)} + \frac{2V \tan^2 \beta}{\gamma(h^2 - d_c^2)}}{A}$$

$$c_2 = \frac{-\left(-\frac{1}{3}\right) + \frac{2(0.4)}{0.12(103.7)} + \frac{2(-307.20)\left(\frac{1}{9}\right)}{0.12(9156.71)}}{0.623441} = 0.538132$$

$$\alpha = \tan^{-1} \left(\frac{c_1 + \sqrt{c_1^2 + 4c_2}}{2} \right)$$

$$\alpha = 25.29^\circ \neq 30^\circ$$

$$\text{Let } \alpha = 25.29^\circ, \quad d_c = \frac{3.333}{0.386256} = 8.63 \text{ ft}$$

$$A = \frac{2(0.4)}{0.12(104.63)} - \frac{2(-307.2)}{0.12(9141.52)} = 0.623799$$

$$c_1 = \frac{\frac{4(0.4)\left(-\frac{1}{3}\right)}{0.12(104.63)} - \frac{4(-307.2)\left(-\frac{1}{3}\right)}{0.12(9141.52)}}{0.623799} = -0.666666$$

$$c_2 = \frac{-\left(-\frac{1}{3}\right) + \frac{2(0.4)}{0.12(104.63)} + \frac{2(-307.2)\left(\frac{1}{9}\right)}{0.12(9141.52)}}{0.623799} = 0.536741$$

$$\alpha = 25.25^\circ \neq 25.29^\circ$$

$$\text{Let } \alpha = 25.25^\circ, \quad d_c = \frac{3.333}{0.385812} = 8.64 \text{ ft}$$

$$A = \frac{2(0.4)}{0.12(104.64)} - \frac{2(-307.2)}{0.12(9141.35)} = 0.623803$$

$$c_1 = \frac{\frac{4(0.4)\left(-\frac{1}{3}\right)}{0.12(104.64)} - \frac{4(-307.2)\left(-\frac{1}{3}\right)}{0.12(9141.35)}}{0.623803} = -0.666666$$

$$c_2 = \frac{-\left(-\frac{1}{3}\right) + \frac{2(0.4)}{0.12(104.64)} + \frac{2(-307.2)\left(\frac{1}{9}\right)}{0.12(9141.35)}}{0.623803} = 0.536726$$

$$\alpha = \underline{\underline{25.246^\circ}} \approx \underline{\underline{25.25^\circ}}, \quad \underline{\underline{d_c}} = \underline{\underline{8.64 \text{ ft}}}$$

(4) Calculate pressure coefficients (see Appendix H) and earth forces:

$$K = \frac{1 - \tan \phi_d \cot \alpha}{1 + \tan \phi_d \tan \alpha} = \frac{1 - 0(2.120303)}{1 + 0(0.471631)} = 1$$

$$K_1 = K \left(\frac{\tan \alpha}{\tan \alpha - \tan \beta} \right) = 1 \left(\frac{0.471631}{0.804964} \right) = 0.585903$$

$$K_v = K \tan \alpha = 1(0.471631) = 0.471631$$

$$P_\gamma = \frac{1}{2} K_1 \gamma (h - d_c)^2 = \frac{1}{2} (0.585903)(0.12)(96 - 8.64)^2 = 268.29 \text{ k/ft}$$

$$P_v = K_v V = 0.471631(-307.2) = -144.89 \text{ k/ft}$$

$$P_{EE} = P_\gamma + P_v = 268.29 - 144.89 = \underline{\underline{123.40 \text{ k/ft}}}$$

(5) Pressure distribution. The negative horizontal pressure, due to P_v , at point E must cancel the positive pressure, due to P_γ .

$$P_{\gamma E} = 0.585903(0.12)(64 - 8.64) = 3.8923 \text{ ksf}$$

$$P_{vE} = -3.8923 \text{ ksf}$$

$$h_v = \text{distribution length for } P_v = \frac{2(-144.89)}{-3.8923} = 74.45 \text{ ft}$$

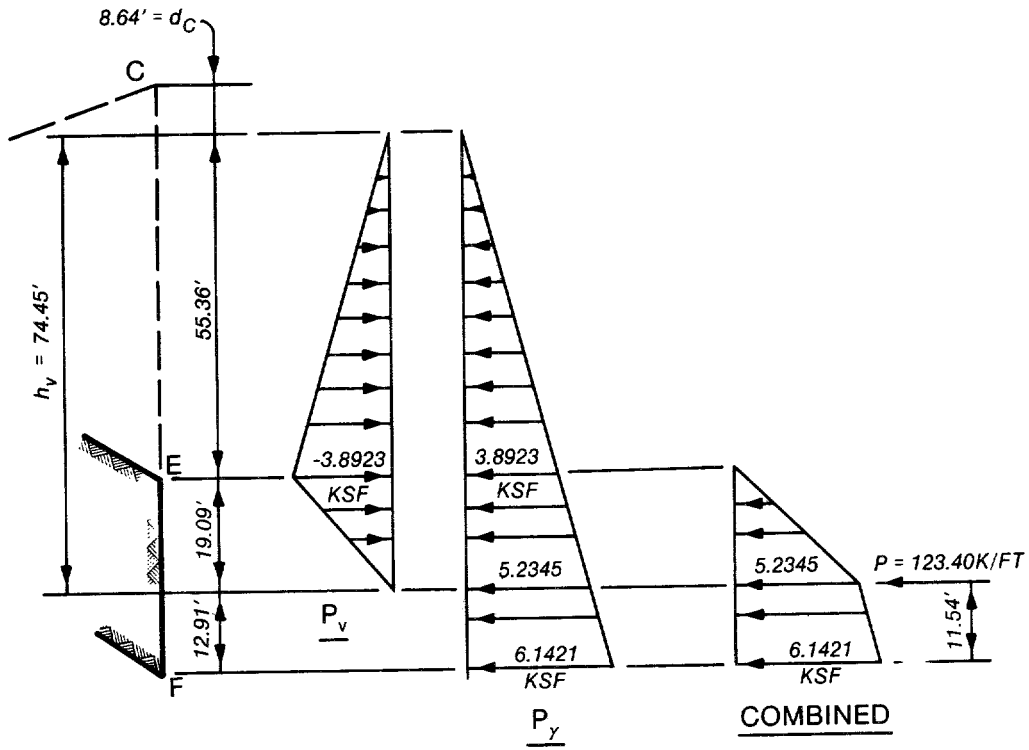

M-9. EXAMPLE 9. Compute lateral earth pressure using pressure coefficients. Check by wedge method.

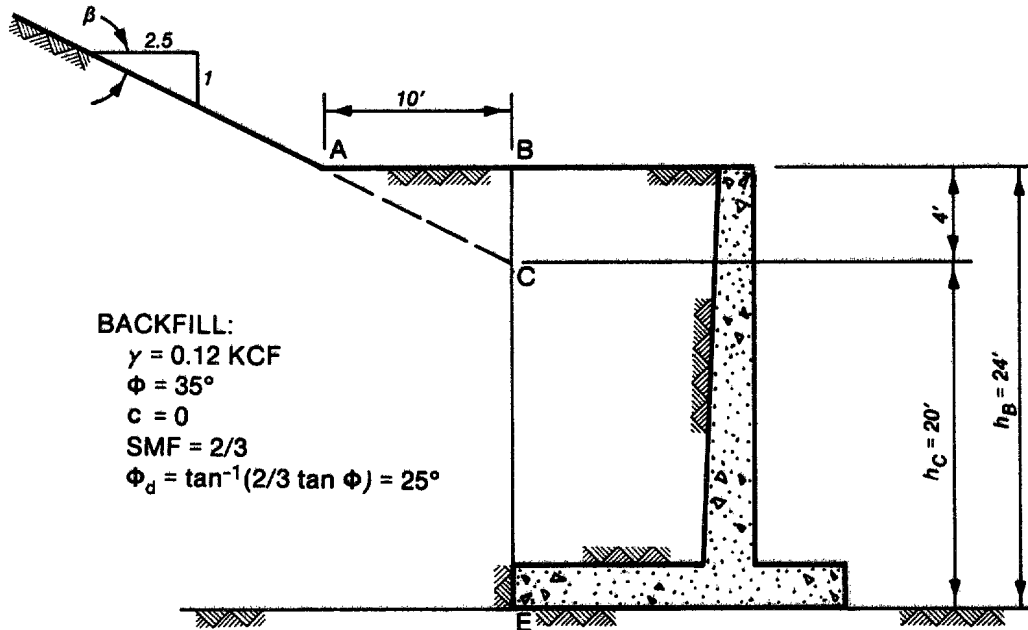

a. Find critical slip-plane angle. Consider basic wedge to have height of 20 feet (h_c), with sloping top surface ($\tan \beta = 0.4$). The weight of triangle ABC will be considered a finite surcharge (V).

$$V = \frac{1}{2} (0.12) (10) (4) = 2.4 \text{ k}$$

From Equation 3-30

$$A = \tan \phi_d - \frac{2V(1 + \tan^2 \phi_d)}{\gamma h_c^2} = 0.466308 - \frac{2(2.4)(1.217443)}{0.12(20)^2}$$

$$A = 0.344564$$

From Equation 3-28

$$c_1 = \left[2 \tan^2 \phi_d - \frac{4V \tan \beta (1 + \tan^2 \phi_d)}{\gamma h_c^2} \right] \div A$$

$$c_1 = \left[2(0.217443) - \frac{4(2.4)(0.4)(1.217443)}{0.12(20)^2} \right] \div 0.344564$$

$$c_1 = 0.979471$$

From Equation 3-29

$$c_2 = \left[\tan \phi_d (1 - \tan \phi_d \tan \beta) - \tan \beta + \frac{2V \tan^2 \beta (1 + \tan \phi_d)^2}{\gamma h_c^2} \right] \div A$$

$$c_2 = \left[0.466308(1 - 0.466308 \times 0.4) - 0.4 + \frac{2(2.4)(0.16)(1.217443)}{0.12(20)^2} \right]$$

$$\div 0.344564$$

$$c_2 = -0.003454$$

$$\alpha = \tan^{-1} \left(\frac{c_1 + \sqrt{c_1^2 + 4c_2}}{2} \right) = \underline{\underline{44.302^\circ}} \quad [3-25]$$

b. Calculate earth pressure coefficients (Appendix H).

$$K = \frac{1 - \tan \phi_d \cot \alpha}{1 + \tan \phi_d \tan \alpha} = \frac{1 - 0.466308 \times 1.024667}{1 + 0.466308 \times 0.975927}$$

$$K = \underline{\underline{0.3589}}$$

$$K_1 = K \left(\frac{\tan \alpha}{\tan \alpha - \tan \beta} \right) = 0.3589 \left(\frac{0.975927}{0.575927} \right) = \underline{\underline{0.6082}}$$

The earth pressure distribution is calculated in the following figures.

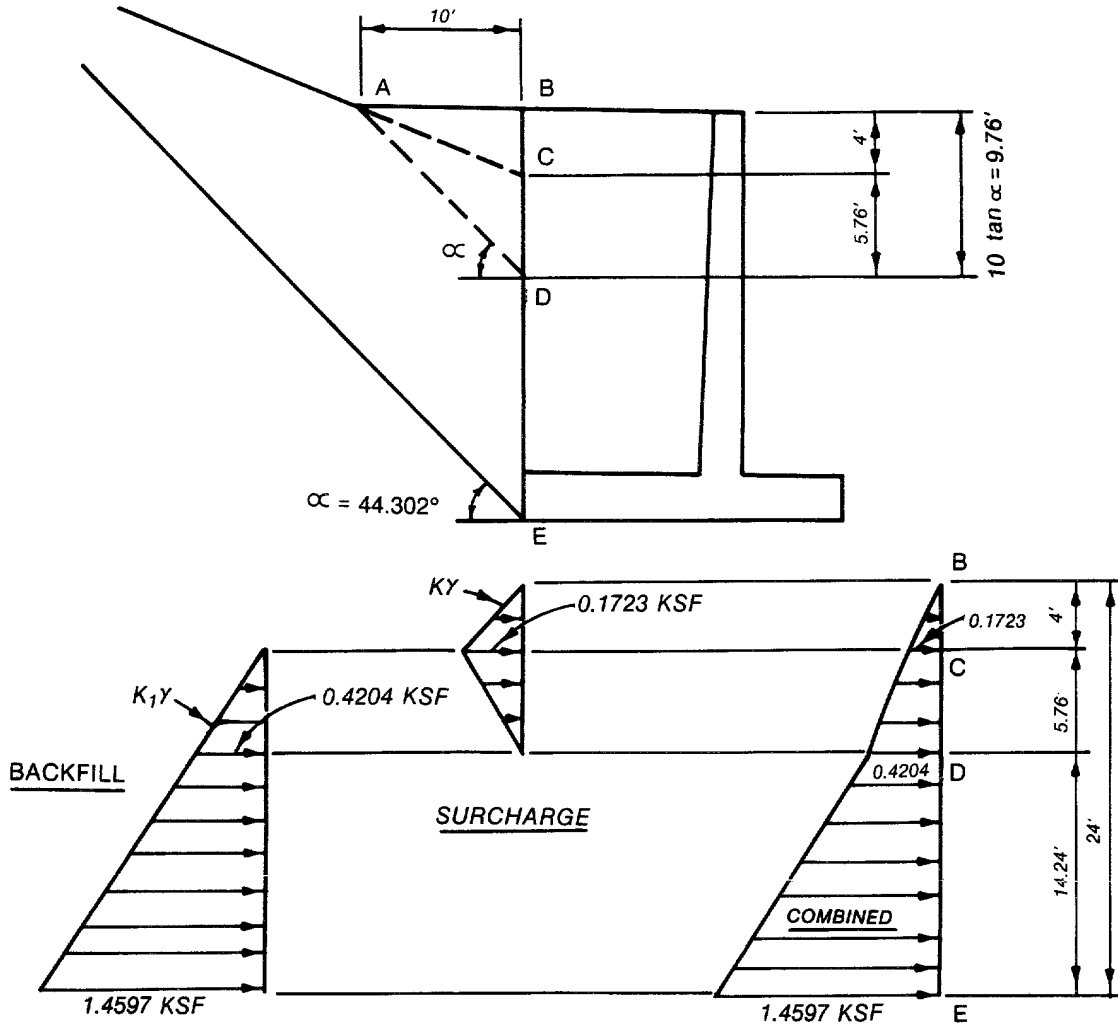

c. Check pressure using the wedge method.

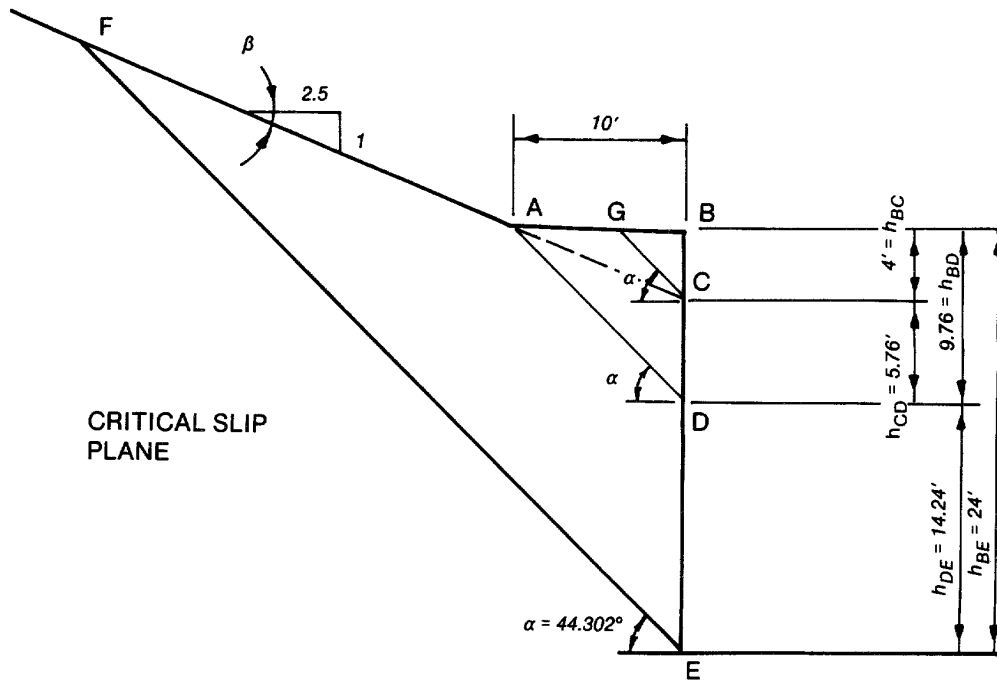

Force on Surface BC.

$$\text{Weight of wedge GBC} = W = \frac{\gamma h_{BC}^2}{2 \tan \alpha} = \frac{0.12(4)^2}{2(0.975927)} = 0.9837 \text{ k}$$

From Equation 3-23

$$P_{BC} = \frac{W (\tan \alpha - \tan \phi_d)}{1 + \tan \phi_d \tan \alpha} = \frac{0.9837(0.975927 - 0.466308)}{1 + 0.466308(0.975927)} = \underline{\underline{0.345 \text{ k}}}$$

Force on Surface BD.

$$\text{Weight of wedge ABD} = W = \frac{1}{2} (0.12)(10)(9.76) = 5.8560 \text{ k}$$

$$P_{BD} = \frac{5.8560(0.975927 - 0.466308)}{1 + 0.466308(0.975927)} = \underline{\underline{2.051 \text{ k}}}$$

Force on Surface BE.

$$\text{Weight of wedge FABE} = W = \frac{\gamma h_{CE}^2}{2 (\tan \alpha - \tan \beta)} + \frac{1}{2} (0.12)(10)(4)$$

$$W = \frac{0.12(20)^2}{2(0.975927 - 0.4)} + 2.4 = 44.0719 \text{ k}$$

$$P_{BE} = \frac{44.0719(0.975927 - 0.466308)}{1 + 0.466308(0.975927)} = \underline{\underline{15.435 \text{ k}}}$$

Calculate pressures at C, D, and E.

$$P_C = \frac{2P_{BC}}{h_{BC}} = \frac{2(0.345)}{4} = 0.1725 \text{ ksf}$$

$$P_D = \frac{2(P_{BD} - P_{BC})}{h_{CD}} - P_C = \frac{2(2.051 - 0.345)}{5.76} - 0.1725 = 0.4199 \text{ ksf}$$

$$P_E = \frac{2(P_{BE} - P_{BD})}{h_{DE}} - P_D = \frac{2(15.435 - 2.051)}{14.24} - 0.4199 = 1.4599 \text{ ksf}$$

The pressure diagram-wedge method is shown on the following page.

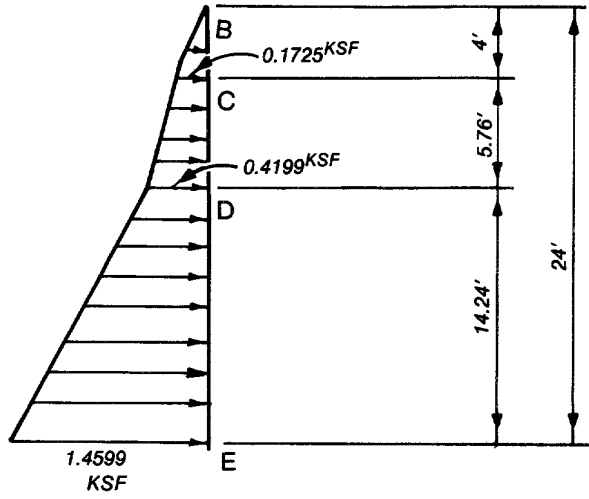

Checks combined pressure diagram obtained using pressure coefficients.

M-10. EXAMPLE 10. Calculate lateral earth pressure. Use the approximate wedge method as well as the elastic method to find pressure due to the distributed finite surcharge.

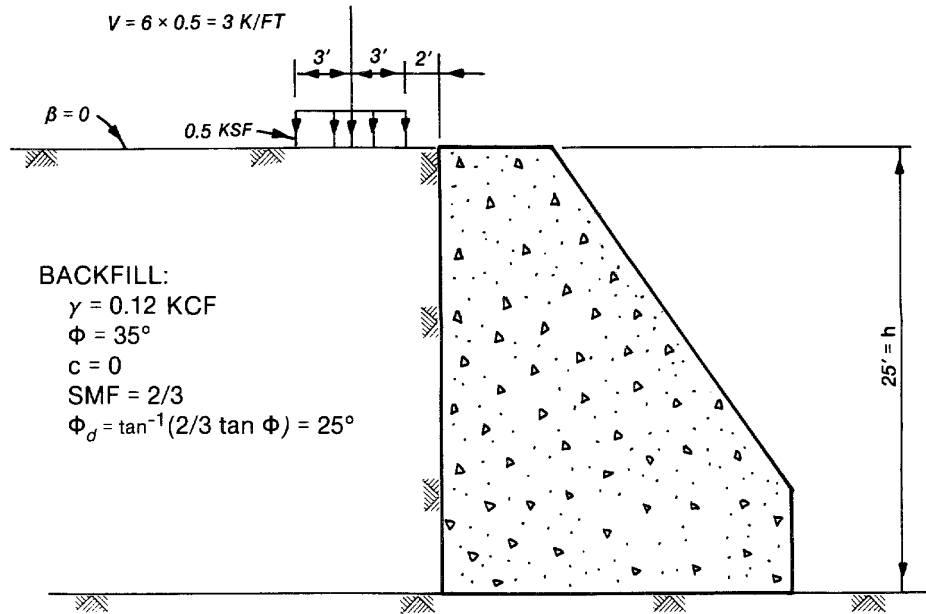

a. Find critical slip-plane angle and lateral force using pressure coefficients. From Equation 3-30

$$A = \tan \phi_d - \frac{2V (1 + \tan^2 \phi_d)}{\gamma h^2} = 0.466308 - \frac{2(3)(1.217443)}{0.12(25)^2}$$

$$A = 0.368913$$

From Equation 3-28

$$c_1 = \frac{2 \tan^2 \phi_d}{A} = \frac{2(0.466308)^2}{0.368913} = 1.178832$$

From Equation 3-29

$$c_2 = \frac{\tan \phi_d}{A} = \frac{0.466308}{0.368913} = 1.264005$$

$$\alpha = \tan^{-1} \left(\frac{c_1 + \sqrt{c_1^2 + 4c_2}}{2} \right) = \underline{\underline{61.721^\circ}} \quad [3-25]$$

From Appendix H, the pressure coefficients are:

$$K = \frac{1 - \tan \phi_d \cot \alpha}{1 + \tan \phi_d \tan \alpha} = \frac{1 - 0.466308 \times 0.537972}{1 + 0.466308 \times 1.858833}$$

$$K = \underline{\underline{0.4013}}$$

$$K_v = K \tan \alpha = 0.4013(1.858833) = 0.7459$$

$$P_\gamma = \frac{1}{2} K_\gamma h^2 = \frac{1}{2} (0.4013)(0.12)(25)^2 = 15.05 \text{ k}$$

$$P_v = K_v V = 0.7459(3) = 2.24 \text{ k}$$

$$P_{\text{(total)}} = P_\gamma + P_v = 15.05 + 2.24 = \underline{\underline{17.29 \text{ k}}}$$

Approximate method-pressure distribution for surcharge (see Figure 3-29).

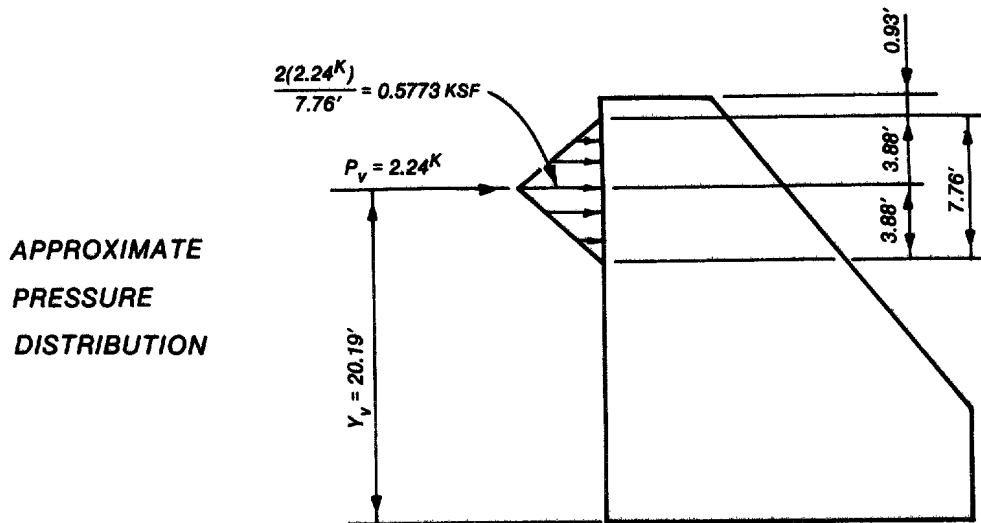
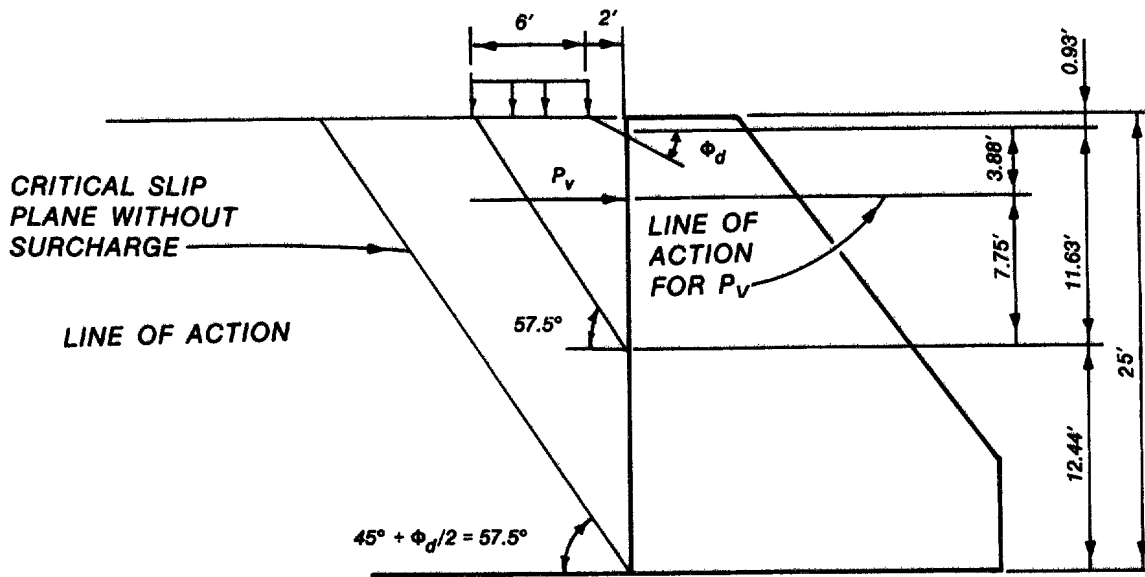

b. Find pressure distribution due to surcharge using the elastic method (see Figure 3-27). Assume nonyielding wall.

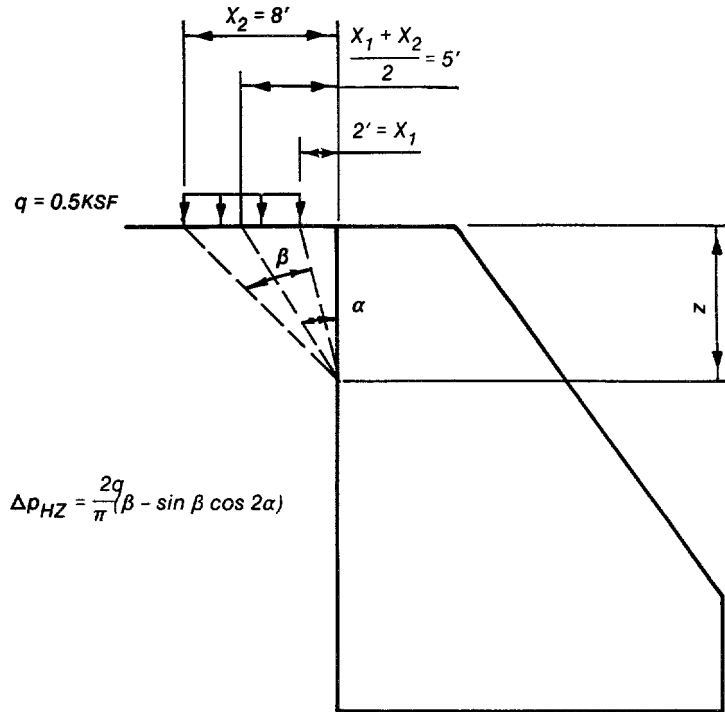

z , ft	$\frac{2q}{\pi}$	β , rad	α°	Δp_{HZ} , ksf
1.25	0.3183	0.4036	75.96	0.239
2.50	0.3183	0.5932	63.43°	0.296
5.00	0.3183	0.6316	45.00	0.201
7.50	0.3183	0.5570	36.69	0.113
10.00	0.3183	0.4773	26.57	0.064
12.50	0.3183	0.4107	21.80	0.039
15.00	0.3183	0.3574	18.43	0.025
17.50	0.3183	0.3150	15.95	0.017
20.00	0.3183	0.2808	14.04	0.012
22.50	0.3183	0.2530	12.53	0.008
25.00	0.3183	0.2298	11.31	0.006

Pressure diagram-elastic method.

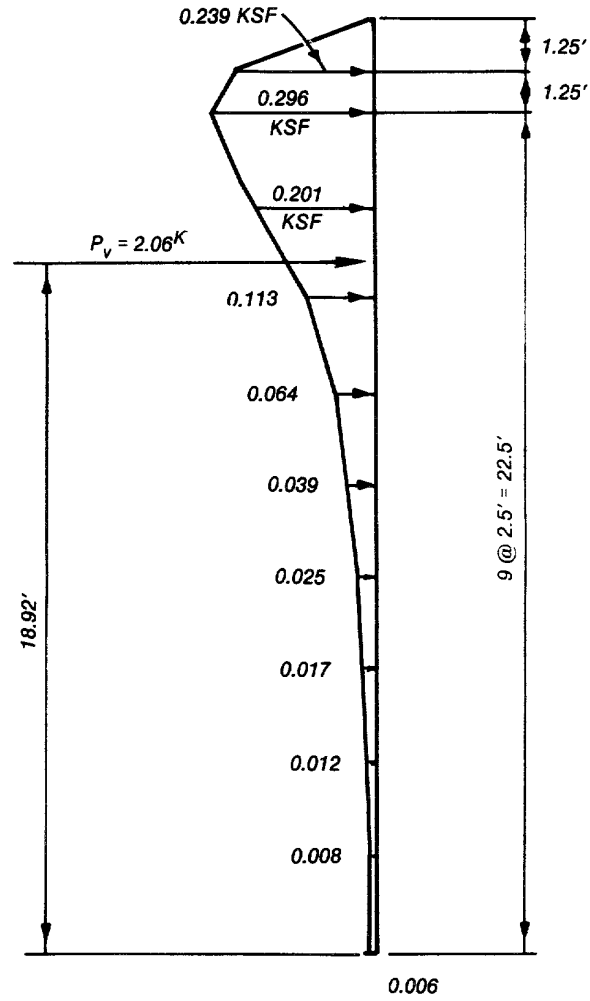

The force, due to the surcharge, determined by the approximate method is more severe. It will be combined with the backfill force to obtain the total force.

Combined pressure diagram and force:

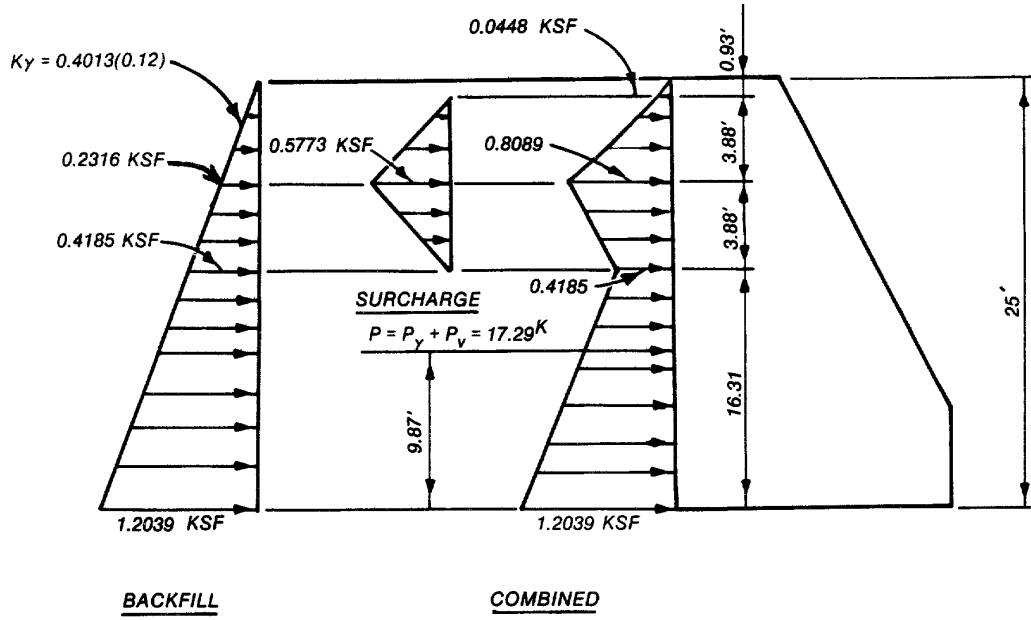

M-11. EXAMPLE 11. Find the lateral forces and pressures acting on the wall for the seismic condition.

Soil properties (on both sides of wall):

$$\begin{aligned}\gamma &= 0.12 \text{ k/ft}^3 \text{ (moist weight)} \\ \gamma_b &= 0.0625 \text{ k/ft}^3 \text{ (buoyancy weight)} \\ \gamma_s &= 0.125 \text{ k/ft}^3 \text{ (saturated weight)} \\ \phi &= 35^\circ, \quad c = 0\end{aligned}$$

Seismic coefficients:

$$\begin{aligned}k_H &= 0.20 \\ k_V &= 0\end{aligned}$$

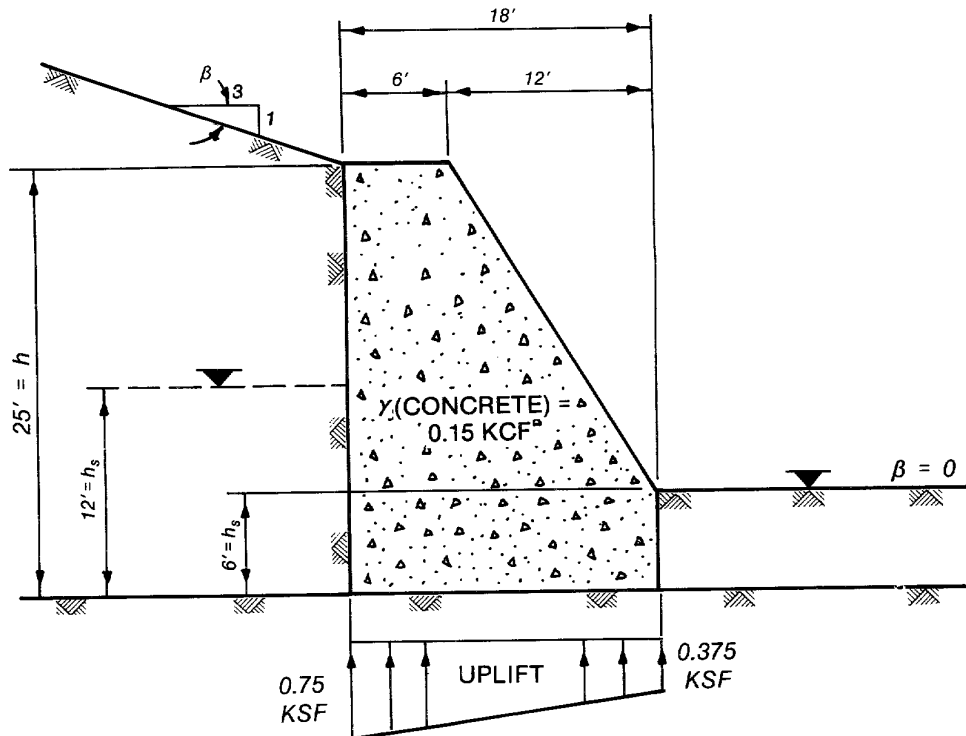

a. Find forces acting on driving side.

$$c_1 = \frac{2 (\tan \phi - k_h)}{1 + k_h \tan \phi} = \frac{2(0.700208 - 0.2)}{1 + 0.2(0.700208)} = 0.877526 \quad [3-57]$$

$$c_2 = \frac{\tan \phi (1 - \tan \phi \tan \beta) - (\tan \beta + k_h)}{\tan \phi (1 + k_h \tan \phi)} \quad [3-58]$$

$$c_2 = \frac{0.700208 \left(1 - 0.700208 \times \frac{1}{3}\right) - \left(\frac{1}{3} + 0.2\right)}{0.700208(1 + 0.2 \times 0.700208)} = 0.004315$$

$$\alpha = \tan^{-1} \left(\frac{c_1 + \sqrt{c_1^2 + 4c_2}}{2} \right) = \underline{\underline{41.426^\circ}} \quad [3-56]$$

$$K = \frac{1 - \tan \phi \cot \alpha}{1 + \tan \phi \tan \alpha} = \frac{1 - 0.700208(1.133240)}{1 + 0.700208(0.882425)}$$

$$K = 0.12763$$

$$K_A = K \left(\frac{\tan \alpha}{\tan \alpha - \tan \beta} \right) = 0.12763 \left(\frac{0.882425}{0.882425 - \frac{1}{3}} \right) = \underline{\underline{0.2051}} \quad [3-54]$$

$$K_b = K \left[1 + \left(\frac{\tan \alpha}{\tan \alpha - \tan \beta} - 1 \right) \left(\frac{\gamma}{\gamma_b} \right) \right] \quad (\text{see Appendix H})$$

$$K_b = 0.12763 \left[1 + \left(\frac{0.882425}{0.549092} - 1 \right) \left(\frac{0.12}{0.0625} \right) \right] = \underline{\underline{0.2764}}$$

$$P_A = \frac{1}{2} K_A \gamma (h - h_s)^2 + \frac{1}{2} (h_s) \left[2K\gamma(h - h_s) + K_b \gamma_b h_s \right] \quad [3-69]$$

$$P_A = \frac{1}{2} (0.2051)(0.12)(13)^2 + \frac{1}{2} (12) \left[2(0.2051)(0.12)(13) \right. \\ \left. + 0.2764(0.0625)(12) \right]$$

$$P_A = \underline{\underline{7.16 \text{ k}}}$$

$$\Delta P_{AE} = k_h \left[\frac{\gamma h^2}{2 (\tan \alpha - \tan \beta)} + \frac{(\gamma_s - \gamma) h_s^2}{2 \tan \alpha} \right] \quad [3-71]$$

$$\Delta P_{AE} = 0.2 \left[\frac{0.12(25)^2}{2(0.549092)} + \frac{0.005(12)^2}{2(0.882425)} \right] = \underline{\underline{13.74 \text{ k}}}$$

$$P_{ws} = \frac{1}{2} \gamma_w h_s^2 = \frac{1}{2} (0.0625)(12)^2 = \underline{\underline{4.50 \text{ k}}} \quad [3-70]$$

b. Find forces acting on resisting side.

$$c_1 = \frac{2 (\tan \phi - k_h)}{1 + k_h \tan \phi} = \frac{2(0.700208 - 0.2)}{1 + 0.2(0.700208)} = 0.877526 \quad [3-60]$$

From Equation 3-61

$$c_2 = \frac{\tan \phi - k_h}{\tan \phi (1 + k_h \tan \phi)}$$

$$c_2 = \frac{0.700208 - 0.2}{0.700208(1 + 0.2 \times 0.700208)} = 0.626618$$

$$\alpha = \tan^{-1} \left(\frac{-c_1 + \sqrt{c_1^2 + 4c_2}}{2} \right) = \underline{\underline{24.999^\circ}} \quad [3-59]$$

From Equation 3-77

$$K_P = \frac{1 + \tan \phi \cot \alpha}{1 - \tan \phi \tan \alpha} = \frac{1 + 0.700208(2.144605)}{1 - 0.700208(0.466286)}$$

$$K_P = \underline{\underline{3.7144}}$$

From Equation 3-73

$$P_P = \frac{1}{2} K_P \gamma_b h^2 = \frac{1}{2} (3.7144)(0.0625)(6)^2 = \underline{\underline{4.18 \text{ k}}}$$

From Equation 3-75

$$\Delta P_{PE} = k_h \left(\frac{\gamma_s h^2}{2 \tan \alpha} \right) = 0.2 \left[\frac{0.125(6)^2}{2(0.466286)} \right] = \underline{\underline{0.97 \text{ k}}}$$

$$P_{ws} = \frac{1}{2} \gamma_w h_s^2 = \frac{1}{2} (0.0625)(6)^2 = \underline{\underline{1.13 \text{ k}}} \quad [3-74]$$

c. Find inertia force due to weight of wall.

$$18' \times 25' \times 0.15 = 67.50 \times 12.50' = 843.75$$

$$-\frac{1}{2} \times 12' \times 19' \times 0.15 = \frac{-17.10}{W = 50.40 \text{ k}} \times 18.67' = \frac{-319.25}{524.50}$$

$$\bar{y} = \frac{524.50}{50.40} = \underline{\underline{10.41 \text{ ft}}}$$

$$k_h W = 0.2(50.40 \text{ k}) = \underline{\underline{10.08 \text{ k}}}$$

d. Summary of forces and pressure distributions.

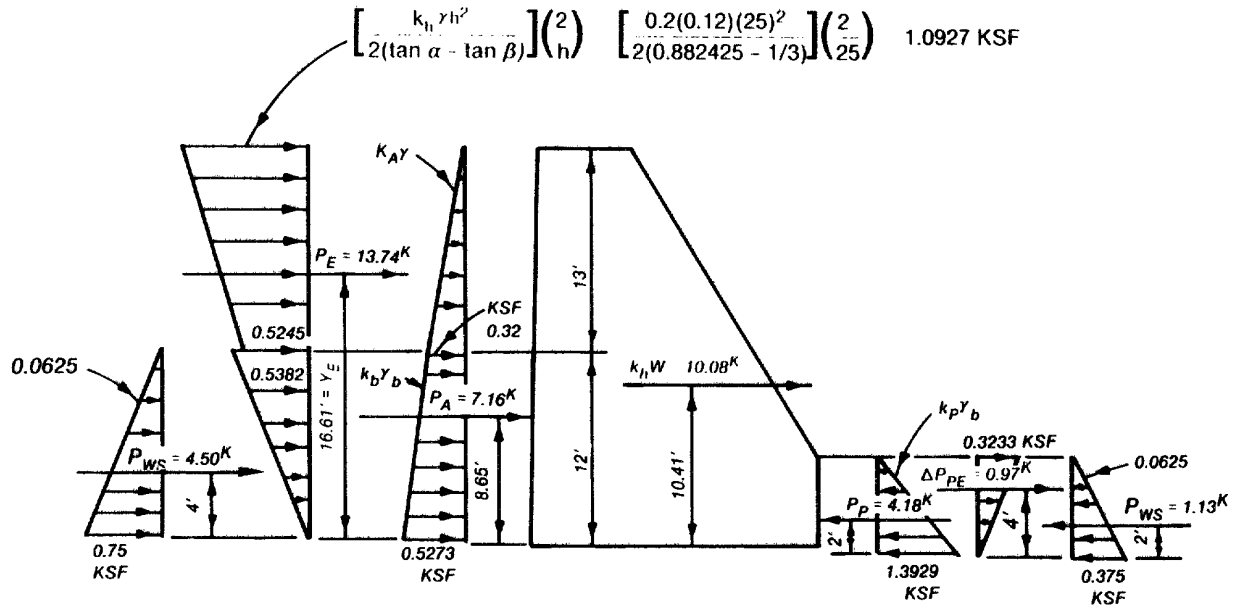

Permissible simplification for dynamic earth pressure distribution--driving side:

The discontinuity of this pressure diagram, at the water table, may be eliminated by considering that the soil weight above and below water is equal to the moist weight. The difference is not significant.

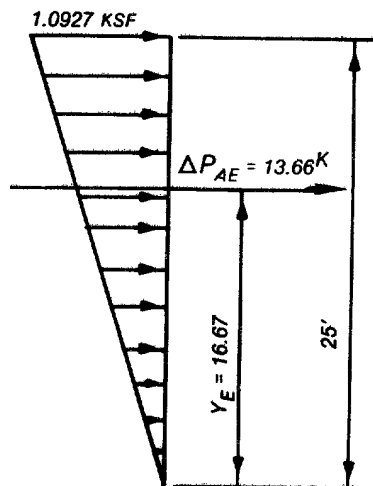

In this case, the difference in forces is -0.58% and difference in dimension, Y_E , is +0.36%.

29 Sep 89

Mononobe-okabe force and pressure distribution--resisting side.

If the pressure diagrams for P_p and ΔP_{PE} (on the preceding page) are combined, negative pressure will be obtained for some distance below the top of ground. Since earth pressure can not pull on the wall, the pressure diagram and force should be determined by setting all negative pressures to zero.

APPENDIX N

STABILITY, BEARING CAPACITY, AND REINFORCEMENT COMPUTATIONS, EXAMPLES

SUMMARY OF EXAMPLES

Example 1, Page N-3

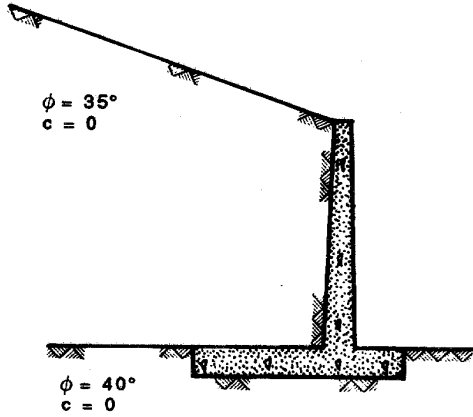

Example 3, Page N-24

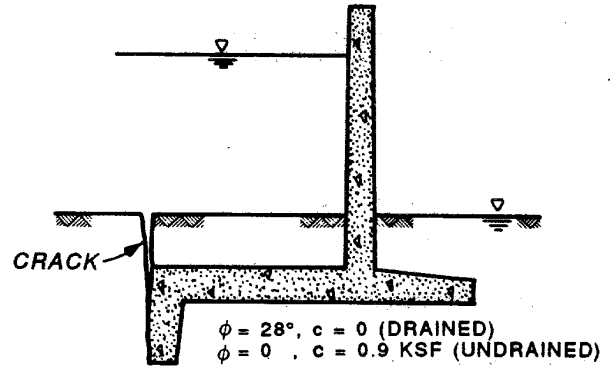

Example 2, Page N-18

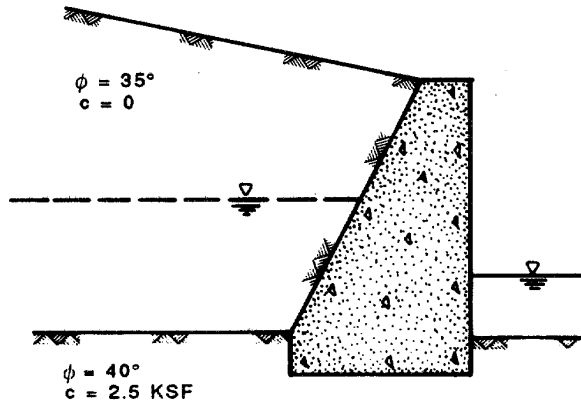

Example 4, Page N-41

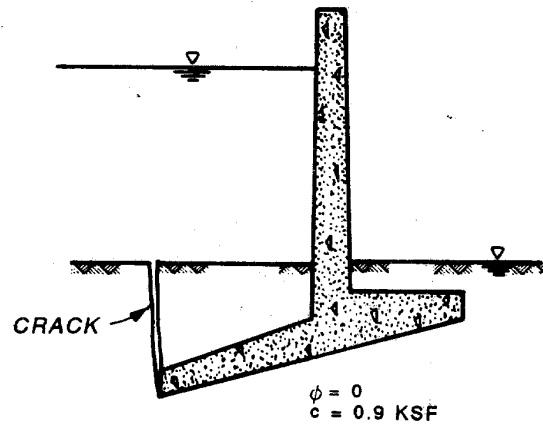

Example 5, Page N-52

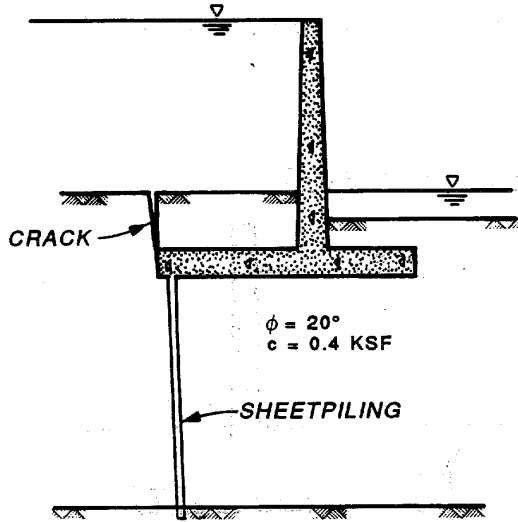

Example 7, Page N-63

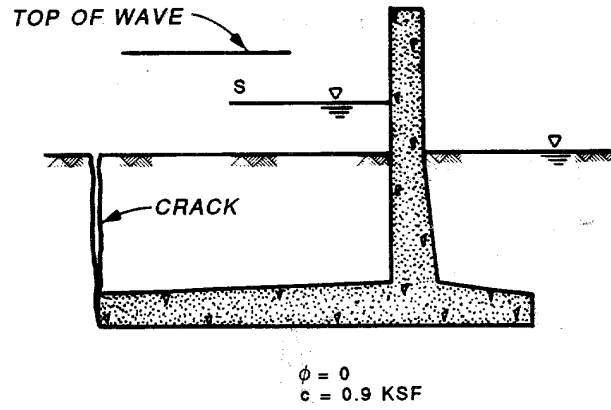

Example 6, Page N-57

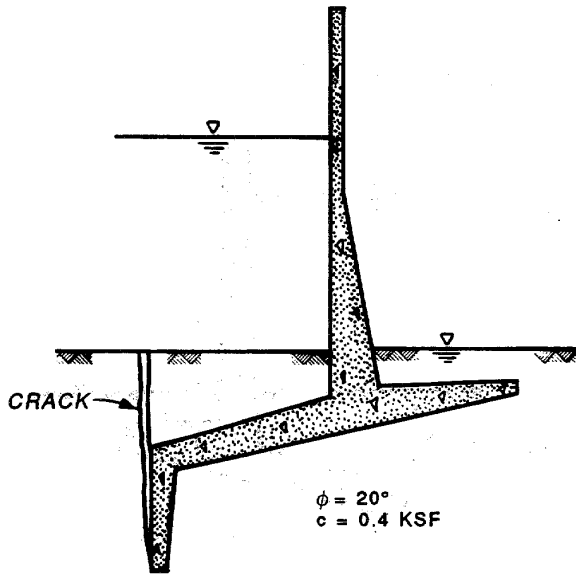

a. Find critical slip-plane angles--driving side.

(1) Foundation (see Appendix G):

$$\phi = 40^\circ, \text{ SMF} = 2/3, \quad \phi_d = \tan^{-1} (2/3 \tan \phi) = 29^\circ$$

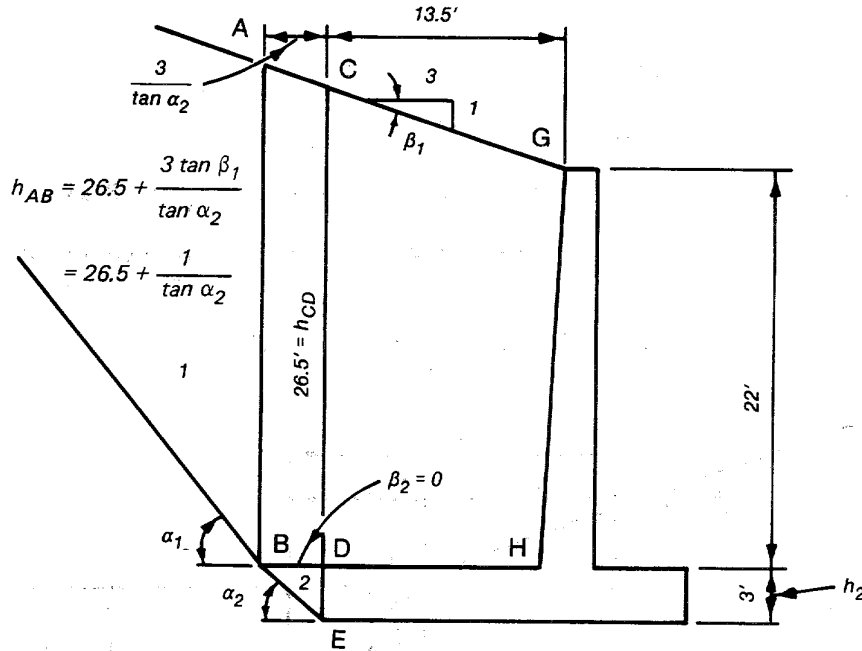

The increased unit weight in the bottom layer (layer 2) is calculated as

$$\gamma' = \frac{2\gamma_1 h_1}{h_2} + \gamma_2 + \frac{2\gamma_1 (\tan \beta_1 - \tan \beta_2)}{\tan \alpha_2 - \tan \beta_2} \quad [G-25]$$

$$\gamma' = \frac{2(0.12)(26.5)}{3} + 0.135 + \frac{2(0.12)(1/3)}{\tan \alpha_2} = 2.255 + \frac{0.08}{\tan \alpha_2}$$

$$V_\alpha = \frac{\gamma_1 h_2^2 (\tan \beta_1 - \tan \beta_2)}{2 (\tan \alpha_2 - \tan \beta_2)^2} \quad [G-26]$$

$$V_{\alpha} = \frac{0.12(3)^2(1/3)}{2 \tan^2 \alpha_2} = \frac{0.18}{\tan^2 \alpha_2}$$

Let $\alpha_2 = 59.5^\circ = 45 + \frac{\phi_d}{2}$,

$$\gamma' = 2.255 + \frac{0.08}{1.697663} = 2.302,$$

$$V_{\alpha} = \frac{0.18}{(1.697663)^2} = 0.0625$$

From Equation G-27 (omitting the c term)

$$A' = \tan \phi_d - \frac{2V_{\alpha}(1 + \tan^2 \phi_d)}{\gamma' h_2^2}$$

$$A' = 0.554309 - \frac{2(0.0625)(1.307259)}{2.302(3)^2} = 0.546422$$

From Equation G-28 (omitting the c term)

$$c'_1 = \left[2 \tan^2 \phi_d - \frac{4V_{\alpha} \tan \beta_2 (1 + \tan^2 \phi_d)}{\gamma' h_2^2} \right] \div A'$$

$$c'_1 = 2(0.554309)^2 \div 0.546422 = 1.12462$$

From Equation G-29 (omitting the c term)

$$c_2' = \frac{\tan \phi_d (1 - \tan \phi_d \tan \beta_2) - \tan \beta_2 + \frac{2V_\alpha \tan^2 \beta_2 (1 + \tan^2 \phi_d)}{\gamma' h_2^2}}{A'}$$

$$c_2' = 0.554309 \div 0.546422 = 1.01443$$

$$\alpha_2 = \tan^{-1} \left(\frac{c_1' + \sqrt{c_1'^2 + 4c_2'}}{2} \right) = 59.77^\circ \approx 59.5^\circ \quad [G-30]$$

Let $\alpha_2 = 59.73^\circ$, $\gamma' = 2.302$, $V_\alpha = 0.061$

$$A' = 0.554309 - \frac{2(0.061)(1.307259)}{2.302(3)^2} = 0.546611$$

$$c_1' = 2(0.554309)^2 \div 0.546611 = 1.124231$$

$$c_2' = 0.554309 \div 0.546611 = 1.014083$$

$$\alpha_2 = 59.76^\circ \quad 59.73^\circ \quad (\text{close enough})$$

$$\alpha_2 = \underline{\underline{59.76^\circ}}$$

(2) Backfill:

$$h_{AB} = 26.5 + \frac{3 \tan \beta_1}{\tan \alpha_2} = \underline{\underline{27.083 \text{ ft}}}, \quad \phi = 35^\circ$$

$$\tan \phi_d = \tan^{-1} (2/3 \tan \phi) = 25^\circ$$

$$c_1 = 2 \tan \phi_d = 2(0.466308) = 0.932616 \quad [3-26]$$

$$c_2 = 1 - \tan \phi_d \tan \beta_1 - \frac{\tan \beta_1}{\tan \phi_d} \quad [3-27]$$

$$c_2 = 1 - 0.466308 \left(\frac{1}{3} \right) - \frac{\frac{1}{3}}{0.466308} = 0.129729$$

$$\alpha_1 = \underline{46.55^\circ} \quad [3-25]$$

b. Earth pressure coefficients (see Appendix H).

(1) Backfill:

$$K_1 = \frac{1 - \tan \phi_d \cot \alpha_1}{1 + \tan \phi_d \tan \alpha_1} \cdot \frac{\tan \alpha_1}{\tan \alpha_1 - \tan \beta_1}$$

$$K_1 = \frac{1 - 0.466308 \times 0.947307}{1 + 0.466308 \times 1.055624} \cdot \frac{1.055624}{1.055624 - \frac{1}{3}} = \underline{0.5468}$$

(2) Foundation:

$$K = \frac{1 - \tan \phi_d \cot \alpha_2}{1 + \tan \phi_d \tan \alpha_2} = \frac{1 - 0.554309 \times 0.582949}{1 + 0.554309 \times 1.715416} = \underline{0.3470}$$

$$K_v = K \tan \alpha_2 = \underline{0.5952}$$

c. Lateral pressure and forces on Surfaces AB and DE.

$$P_{AB} = \frac{1}{2} K_1 \gamma_1 h_{AB}^2 = \frac{1}{2} (0.5468) (0.12) (27.083)^2 = \underline{24.06 \text{ kips}}$$

Surface DE:

$$P_{DE} = \frac{1}{2} K \gamma_2 h_2^2 + K_v V$$

$$V = \frac{1}{2} (h_{AB} + h_{CD}) (\gamma_1) \left(\frac{3}{\tan \alpha_2} \right)$$

$$V = \frac{1}{2} (27.083 + 26.5) (0.12) \left(\frac{3}{1.715416} \right) = 5.623 \text{ kips}$$

$$P_{DE} = \frac{1}{2} (0.347) (0.135) (3)^2 + 0.5952(5.623) = 3.5576 \text{ kips}$$

$$P_B = K_1 \gamma_1 h_{AB} = 0.5468(0.12)(27.083) = 1.7771 \text{ ksf}$$

$$P_D = K \gamma_1 h_{CD} = 0.3470(0.12)(26.5) = 1.1035 \text{ ksf}$$

$$P_{DE} = \left(\frac{P_D + P_E}{2} \right) h_2$$

$$P_E = \frac{2P_{DE}}{h_2} - P_D$$

$$P_E = \frac{2(3.5576)}{3} - 1.1035$$

$$P_E = 1.2683 \text{ ksf}$$

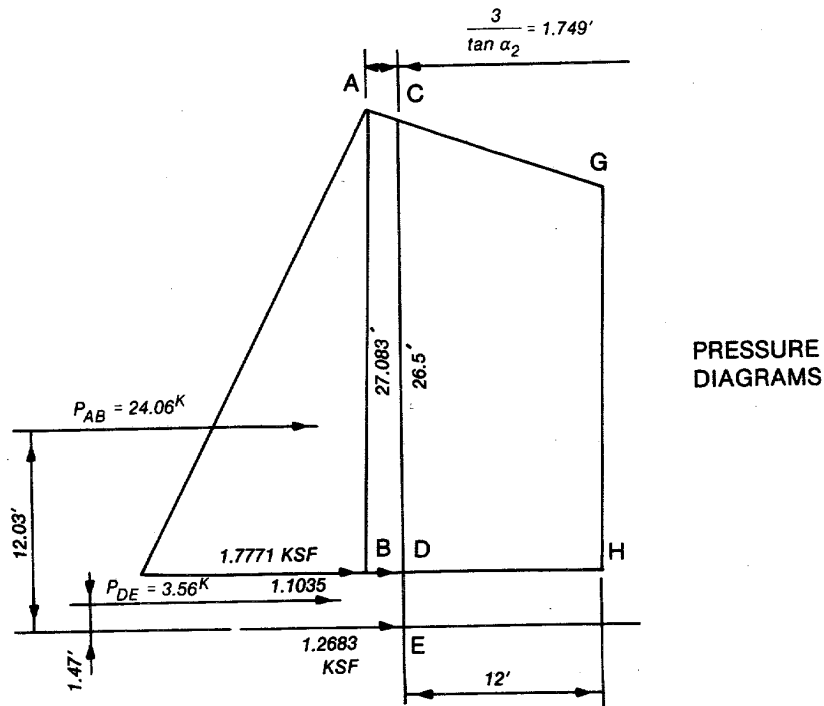

d. Shear force on structural wedge (paragraphs 4-8c, 9-7a).

(1) The horizontal force P_{AB} will be considered to act on any vertical plane in the soil that lies on Surface AB, or on any surface to the right of Surface AB, such as surfaces CD or GH.

(2) In order for the body of soil lying between CD and GH to be in equilibrium, a small vertical shear will be assumed to act on vertical surfaces along with the horizontal force P_{AB} .

(3) The value of this shear force is found from a free body of any block of soil as shown on the following page:

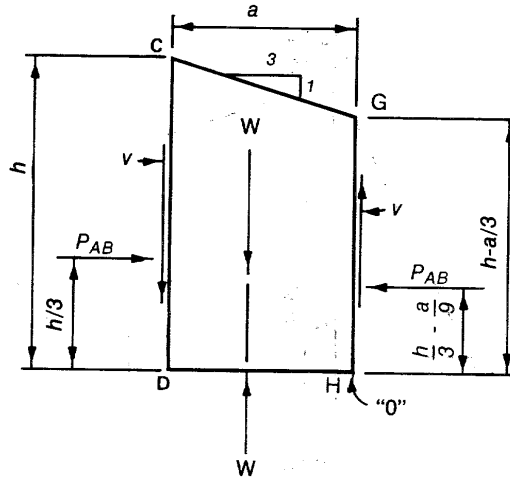

$$\Sigma M_O = 0 = P_{AB} \left[\frac{h}{3} - \left(\frac{h}{3} - \frac{a}{9} \right) \right] - va$$

$$va = P_{AB} \left(\frac{a}{9} \right), \quad v = \frac{P_{AB} \tan \beta}{3} = \frac{P_{AB}}{9} = \frac{24.06}{9} = 2.673 \text{ kips}$$

e. Weight and center of gravity of structural wedge.

$$\begin{aligned}
 &1.5 \text{ ft} \times 22 \text{ ft} \times 0.15 \text{ kcf} = 4.95 \times 5.75 \text{ ft} = 28.46 \text{ kips} \\
 &\frac{1}{2} \times 1.5 \text{ ft} \times 22 \text{ ft} \times 0.15 \text{ kcf} = 2.48 \times 7.00 \text{ ft} = 17.36 \text{ kips} \\
 &20 \text{ ft} \times 3 \text{ ft} \times 0.15 \text{ kcf} = \underline{9.00} \times 10.00 \text{ ft} = \underline{90.00} \text{ kips} \\
 &\text{Concrete} = 16.43 \text{ k/ft} \qquad 135.82 \div 16.43 = 8.27 \text{ ft} = \bar{x}
 \end{aligned}$$

$$\begin{aligned}
 &\frac{1}{2} \times 13.5 \text{ ft} \times 4.5 \text{ ft} \times 0.12 \text{ kcf} = 3.65 \times 15.50 \text{ ft} = 56.58 \\
 &12 \text{ ft} \times 22 \text{ ft} \times 0.12 \text{ kcf} = 31.68 \times 14.00 \text{ ft} = 443.52 \\
 &\frac{1}{2} \times 1.5 \text{ ft} \times 22 \text{ ft} \times 0.12 \text{ kcf} = \underline{1.98} \times 7.50 \text{ ft} = \underline{14.85} \\
 &\text{Soil} = 37.31 \text{ k/ft} \qquad 514.95 \div 37.31 = 13.80 \text{ ft} \\
 &\qquad \qquad \qquad \qquad \qquad \qquad \qquad \qquad \qquad \qquad \qquad \qquad \qquad \qquad \qquad \qquad \qquad \qquad \qquad = \bar{x}
 \end{aligned}$$

f. Overturning stability (paragraph 4-8).

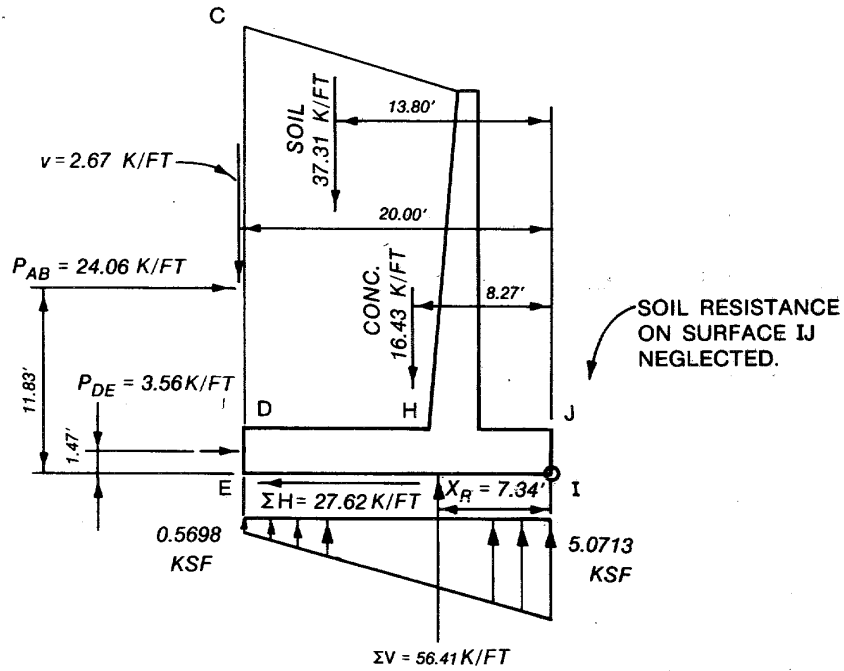

$$\begin{aligned}
 &2.67 \text{ kips} \times 20.00 \text{ ft} = 53.400 \text{ ft-kips} \\
 &37.31 \text{ kips} \times 13.80 \text{ ft} = 514.878 \text{ ft-kips} \\
 &16.43 \text{ kips} \times 8.27 \text{ ft} = 135.876 \text{ ft-kips} \\
 &56.41 = \Sigma V \\
 &27.62 = \Sigma H \\
 &414.291 = \Sigma M_I \\
 &x_R = \frac{414.291}{56.41} = 7.34 \text{ ft} \\
 &-24.06 \times 11.83 = -284.630 \\
 &-3.56 \times 1.47 = -5.233 \\
 &-27.62 = \Sigma H
 \end{aligned}$$

One hundred percent of base is in compression, overturning stability requirement is satisfied.

g. Sliding stability analysis (paragraph 4-15).

$$N' = \Sigma V = 56.41 \text{ kips}, \quad T = \Sigma H = 27.62 \text{ kips}$$

$$T \leq \frac{N' \tan \phi + cL}{FS} \quad [4-12]$$

Using the minimum FS of 1.5 from Table 4-1 yields

$$27.62 \leq \frac{56.41 \tan 40^\circ + 0 (20)}{1.5}$$

$$27.62 \leq 31.56$$

Sliding stability requirement is satisfied.

h. Check bearing capacity (Chapter 5).

$$\delta = \tan^{-1}\left(\frac{27.62}{56.41}\right) = 26^\circ = 0.4538 \text{ rad} \quad (\text{Figure 5-1(a)})$$

$$e = \frac{B}{2} - x_R = \frac{20}{2} - 7.34 = 2.66 \text{ ft}$$

$$\bar{B} = B - 2e = 20 - 2(2.66) = 14.68 \text{ ft}$$

$$q_o = \gamma_D = 0.135(3) = 0.405 \text{ ksf} \quad [5-8a]$$

$$\xi_{qi} = \left(1 - \frac{\delta}{90}\right)^2 = 0.5057 \quad [5-5a]$$

$$\xi_{\gamma i} = \left(1 - \frac{\delta}{\phi}\right)^2 = \left(1 - \frac{26}{40}\right)^2 = 0.1225 \quad [5-5b]$$

$$N_q = 64.20, \quad N_\gamma = 93.69 \quad (\text{Table 5-1})$$

Using Equation 5-2 yields

$$Q = \bar{B} \left(\xi_{qi} q_o N_q + \frac{\xi_{\gamma i} \bar{B} \gamma N_\gamma}{2} \right)$$

$$Q = 14.68 \left[0.5057(0.405)(64.20) + \frac{0.1225(14.68)(0.135)(93.69)}{2} \right]$$

$$Q = 359.97 \text{ kips}$$

For this problem $\Sigma V = N'$. The factor of safety is calculated as

$$FS = \frac{Q}{N'} = \frac{359.97}{56.41} = 6.38 > 3.00 \quad [5-1]$$

Bearing capacity requirement is satisfied (Table 4-1).

i. Reinforcement at base of stem (Chapter 9). Neglect vertical shear component v .

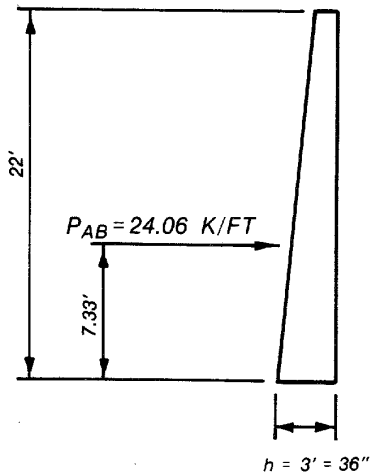

$$M = 24.06(7.33 \text{ ft}) = 176.36 \text{ k-ft}$$

$$k_u = 1 - \sqrt{1 - \frac{\frac{M_u}{\phi}}{0.425f'_c b d^2}}, \quad (\text{Figure 9-2})$$

$$\frac{M_u}{\phi} = \frac{1.9(176.36)(12)}{0.90} = 4,468 \text{ k-in.}$$

$$b = 12 \text{ in.}, \quad d = h - 4.5 = 31.5 \text{ in.}$$

$$0.425f'_c b d^2 = 0.425(4)(12)(31.5)^2 = 20,241.9$$

$$k_u = 1 - \sqrt{1 - \frac{4,468}{20,241.9}} = 0.1174$$

$$C_u = T_u = 0.85f'_c k_u b d$$

$$C_u = T_u = 0.85(4)(0.1174)(12)(31.5)$$

$$= 150.88 \text{ kips}$$

$$A_s = \frac{T_u}{f_y} = \frac{150.88}{48} = \underline{\underline{3.14 \text{ in.}^2/\text{ft}}}$$

Check if ductility requirement of $\rho_{\min} \leq \rho \leq \rho_{\max}$ is satisfied:

$$\rho_{\max} = \lambda \rho_b, \quad \lambda = 0.25 \quad (\text{paragraph 9-8b(3)})$$

$$\rho_{\min} = 200/f_y = 200/48,000 = 0.00417 \quad (\text{paragraph 9-8b(4), from ACI 318})$$

The reinforcement ratio ρ_b in the balanced condition may be obtained by applying equilibrium and compatibility conditions. From the linear strain condition shown below:

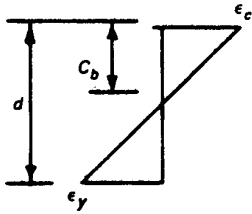

$$\frac{c_b}{d} = \frac{\epsilon_c}{\epsilon_c + \epsilon_y} = \frac{0.003}{0.003 + \frac{f_y}{29,000 \text{ ksi}}}$$

The compressive force C is

$$C = 0.85f'_c \beta_1 b c_b$$

The tensile force is

$$T = f_y A_{sb} = \rho_b b d f_y$$

Equating C to T yields

$$0.85f'_c \beta_1 b c_b = \rho_b b d f_y$$

$$\rho_b = \frac{0.85f'_c}{f_y} \beta_1 \frac{c_b}{d} = \frac{0.85f'_c}{f_y} \beta_1 \left(\frac{\epsilon_c}{\epsilon_c + \frac{f_y}{29,000 \text{ ksi}}} \right)$$

$$\beta_1 = 0.85, \quad \epsilon_c = 0.003 \quad (\text{for nonhydraulic structure, paragraph 9-8e})$$

$$\rho_b = \frac{0.85(4)}{48} (0.85) \left(\frac{0.003}{0.003 + \frac{48}{29,000}} \right) = 0.03880$$

$$\rho_{\max} = 0.25(0.03880) = 0.009700$$

$$\rho = \frac{A_s}{bd} = \frac{3.14}{12(31.5)} = 0.008307$$

$$0.00417 < \rho = 0.008307 < 0.009700$$

Ductility is adequate.

j. Reinforcement in heel at face of stem.

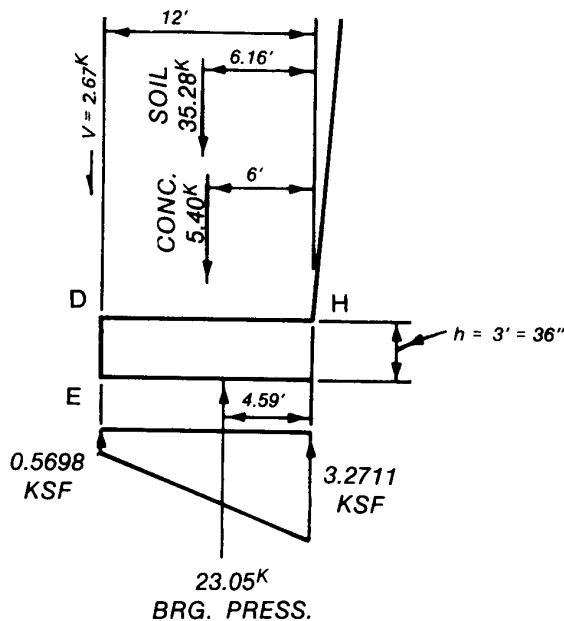

$$\begin{aligned} 2.67 \times 12.00 &= 32.04 \\ 35.28 \times 6.16 &= 217.32 \\ 5.40 \times 6.00 &= 32.40 \\ -23.05 \times 4.59 &= -105.80 \\ M &= 175.96 \text{ k-ft} \end{aligned}$$

From Figure 9-2

$$\frac{M_u}{\phi} = \frac{1.9(175.96)(12)}{0.9} = 4,458 \text{ k-in.}$$

$$b = 12 \text{ in.}, \quad d = 36 - 4.5 = 31.5 \text{ in.}$$

$$0.425f_c'bd^2 = 20,241.9$$

$$k_u = 1 - \sqrt{1 - \frac{4,458}{20,241.9}} = 0.1170$$

$$\begin{aligned} C_u = T_u &= 0.85(4)(0.1170)(12)(31.5) \\ &= 150.37 \text{ kips} \end{aligned}$$

$$A_s = \frac{150.37}{48} = \underline{\underline{3.13 \text{ in.}^2/\text{ft}}}$$

Check ductility:

$$\rho_{\max} = 0.009700, \quad \rho_{\min} = 0.00417$$

$$\rho = \frac{A_s}{bd} = \frac{3.13}{12(31.5)} = 0.008280$$

$$0.00417 < \rho = 0.008280 < 0.009700$$

Ductility is adequate.

k. Reinforcement in toe at face of stem.

$$22.55 \times 2.60 = 58.63$$

$$-2.25 \times 2.50 = -5.625$$

$$M = 53.01 \text{ k-ft}$$

From Figure 9-2

$$\frac{M_u}{\phi} = \frac{1.9(53.01)(12)}{0.9} = 1,342.8 \text{ k-in.}$$

$$b = 12 \text{ in.}, \quad d = 36 \text{ in.} - 4.5 = 31.5 \text{ in.}$$

$$0.425f'_c b d^2 = 20,241.9$$

$$k_u = 1 - \sqrt{1 - \frac{1,342.8}{20,241.9}} = 0.0337$$

$$C_u = T_u = 0.85(4)(0.0337)(12)(31.5)$$

$$= 43.31 \text{ kips}$$

$$A_s = \frac{43.31}{48} = \underline{\underline{0.90 \text{ in.}^2/\text{ft}}}$$

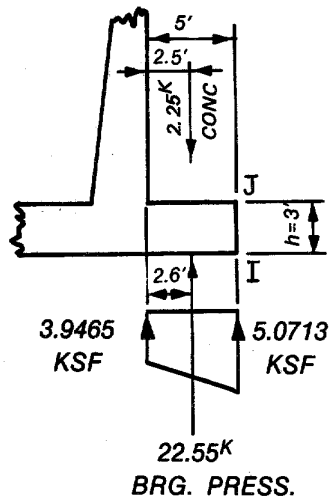

Check ductility:

$$\rho_{\max} = 0.02910, \quad \rho_{\min} = 0.00417$$

$$\rho = \frac{A_s}{bd} = \frac{0.90}{12(31.5)} = 0.002381$$

$$0.00417 < \rho = 0.002381 < 0.009700$$

Ductility is adequate.

1. Shear check (paragraph 9-8f). The shear capacity of the concrete will be checked at a distance d from the base of the stem according to ACI 318.

$$d_v = 31.5 - \frac{1.5}{22} d_v, \quad 1.06818 d_v = 31.5$$

$$d_v = 29.5 \text{ in.} = 2.46 \text{ ft} \quad (\text{member depth for shear at distance } d_v \text{ above base})$$

Since the shear has a quadratic variation, the shear at distance d_v can be calculated as shown below.

$$V = \frac{(22 - 2.46)^2}{(22)^2} (24.06) = 18.98 \text{ kips}$$

$$V_u = 1.9(18.98) = 36.06 \text{ kips}$$

$$\phi V_c = (0.85)(2) \sqrt{f'_c} b d_v \quad (\text{from ACI 318})$$

$$\phi V_c = (0.85)(2) \sqrt{4,000}(12)(29.5) = 38,061 \text{ lb} > V_u$$

Check the shear capacity of the heel at the base of the stem:

$$V = 2.67 + 5.40 + 35.28 - 23.05 = 20.3 \text{ kips}$$

$$V_u = 1.9 (20.3) = 38.57 \text{ kips}$$

$$\phi V_c = (0.85)(2) \sqrt{f'_c} b d_v$$

$$\phi V_c = (0.85)(2) \sqrt{4,000} (12)(31.5) = 40,642 \text{ lb} > V_u$$

N-2. EXAMPLE 2. Analyze the wall below for overturning, sliding and bearing capacity. Case R2, unusual loading condition.

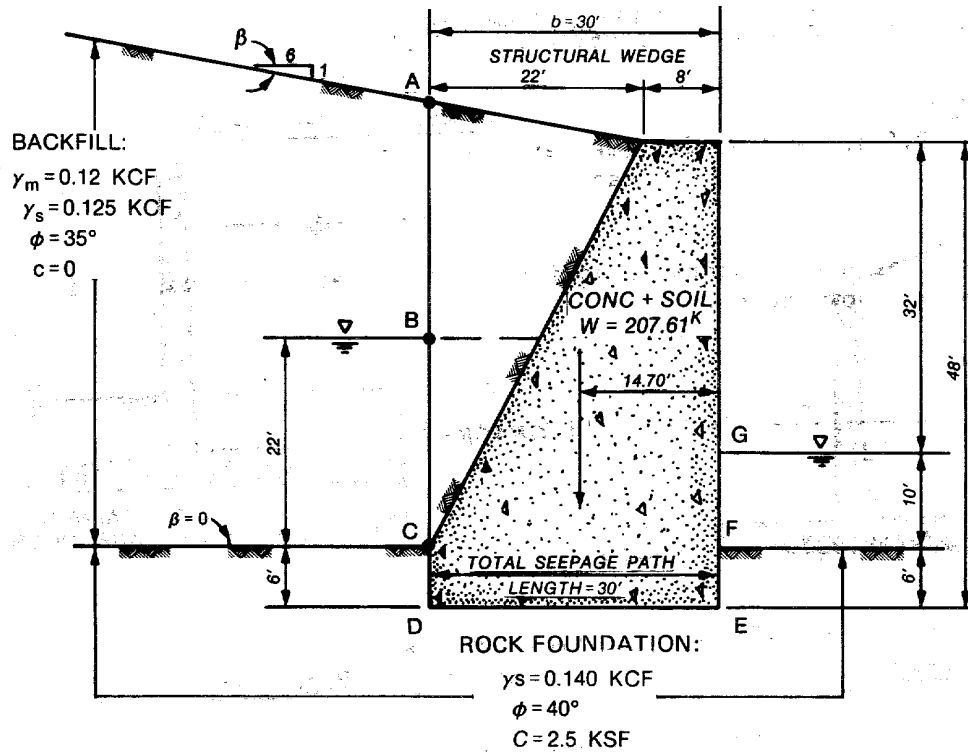

a. Driving side lateral pressure coefficients.

(1) Foundation:

$$SMF = \frac{2}{3}, \quad \phi_d = \tan^{-1} \left(\frac{2}{3} \tan \phi \right) = 29.22^\circ$$

$$K = \tan^2 \left(45^\circ - \frac{\phi_d}{2} \right) = 0.3439 \quad [3-15]$$

$$K_c = \sqrt{K} = 0.5865$$

$$P_{VD} = 23.67(0.12) + 22(0.125) - 28(0.0625) + 6(0.14) = 4.68 \text{ ksf}$$

$$p_{HD} = Kp_v - 2K_c c_d, \quad c_d = \frac{2}{3} c = 1.67 \text{ ksf}$$

$$p_{HD} = 0.3439(4.68) - 2(0.5865)(1.67) = -0.3495 \text{ ksf}$$

Negative horizontal earth pressure at D shows that there will be no earth pressure on Surface CD. Also, no at-rest earth pressure can act on Surface EF.

(2) Backfill:

$$SMF = \frac{2}{3}, \quad \phi_d = \tan^{-1} \left(\frac{2}{3} \tan \phi \right) = 25^\circ$$

$$c_1 = 2 \tan \phi_d = 2(0.466308) = 0.932616 \quad [3-26]$$

$$c_2 = 1 - \tan \phi_d \tan \beta - \frac{\tan \beta}{\tan \phi_d} \quad [3-27]$$

$$c_2 = 1 - 0.466308 \times \frac{1}{6} - \frac{\frac{1}{6}}{0.466308} = 0.564864$$

$$\alpha = \tan^{-1} \left(\frac{c_1 + \sqrt{c_1^2 + 4c_2}}{2} \right) = \underline{\underline{53.49^\circ}} \quad [3-25]$$

$$K_1 = \frac{1 - \tan \phi_d \cot \alpha}{1 + \tan \phi_d \tan \alpha} \cdot \frac{\tan \alpha}{\tan \alpha - \tan \beta} \quad (\text{see Appendix H})$$

$$K_1 = \frac{1 - 0.466308 \times 0.740231}{1 + 0.466308 \times 1.350929} \cdot \frac{1.350929}{1.350929 - \frac{1}{6}} = \underline{\underline{0.4583}} \quad (\text{use above water table})$$

b. Uplift and water pressures (paragraph 3-22, rock foundation assumed).
Since the total seepage path length is the base width, full hydrostatic pressures will exist at points D and E (see paragraph 3-22).

$$u_D = 28 \text{ ft} (0.0625) = \underline{\underline{1.75 \text{ ksf}}}$$

$$u_E = 16 \text{ ft} (0.0625) = \underline{\underline{1.00 \text{ ksf}}}$$

For the same reason the buoyant weights for backfill and foundation materials are:

$$\gamma_b \text{ (Backfill)} = 0.125 - 0.0625 = 0.0625 \text{ kcf}$$

$$\gamma_b \text{ (Foundation)} = 0.140 - 0.0625 = 0.0775 \text{ kcf}$$

c. Buoyant earth pressure coefficient (Appendix H):

$$K = \frac{1 - \tan \phi_d \cot \alpha}{1 + \tan \phi_d \tan \alpha} = 0.40176$$

$$K_b = K \left[1 + \left(\frac{\tan \alpha}{\tan \alpha - \tan \beta} - 1 \right) \left(\frac{\gamma_m}{\gamma_b} \right) \right]$$

$$K_b = 0.40176 \left[1 + \left(\frac{1.350929}{1.350929 - \frac{1}{6}} - 1 \right) \left(\frac{0.12}{0.0625} \right) \right] = \underline{\underline{0.5103}}$$

d. Overtuning stability analysis (paragraph 4-8). For the first trial solution, all of the base is assumed to be in compression (full hydrostatic pressure is applied at points D and E). For the second trial, full hydrostatic pressure is assumed to act over the portion of the base which is not in compression. This procedure is continued until the assumed amount of the base in compression equals the calculated value. The final solution is shown on the following page.

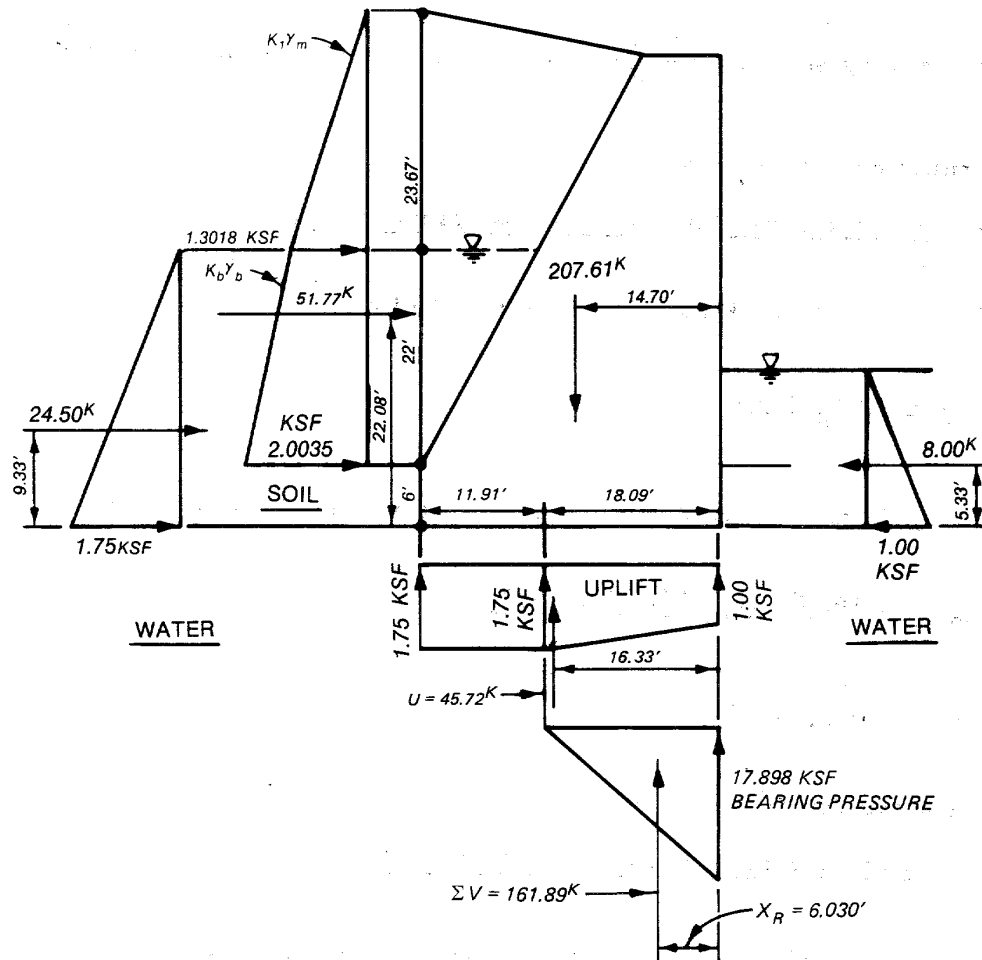

$$207.61 \text{ kips} \times 14.70 = 3051.87 \text{ ft-kips}$$

$$\underline{-45.72 \text{ kips} \times 16.33 = -746.61 \text{ ft-kips}}$$

$$161.89 \text{ kips} = \Sigma V$$

$$-51.77 \text{ kips} \times 22.08 = -1143.081 \text{ ft-kips}$$

$$-24.50 \text{ kips} \times 9.33 = -228.59 \text{ ft-kips}$$

$$\underline{8.00 \text{ kips} \times 5.33 = 42.64 \text{ ft-kips}}$$

$$\underline{-68.27 \text{ kips} = \Sigma H}$$

$$976.23 \div 161.89 = \underline{6.030 \text{ ft} = x_R}$$

Width of base in compression = $3x_R = 18.09$ ft.

Percent in compression = $\left(\frac{18.09}{30}\right) (100) = 60.3\% > 50\%$ required by Table 4.1.

Overturning criterion is satisfied.

e. Sliding stability analysis (paragraph 4-15).

$N' = \Sigma V = 161.89$ kips, $T = \Sigma H = 68.27$ kips

$$T \leq \frac{N' \tan \phi + cL}{FS} \quad [4-12]$$

Using the minimum required FS of 1.33 as given in Table 4-1 yields

$$68.27 \leq \frac{161.89 \tan 40^\circ + 2.5(18.09)}{1.33}$$

$$68.27 \leq 136.14$$

Sliding criterion is satisfied.

f. Bearing capacity analysis (Chapter 5).

$$\delta = \tan^{-1} \left(\frac{\Sigma H}{\Sigma V} \right) = \tan^{-1} \left(\frac{68.27}{161.89} \right) = 22.87^\circ \text{ (Figure 5-1a)}$$

$$e = \frac{B}{2} - x_R = 15 - 6.030 = 8.970 \text{ ft}$$

$$\bar{B} = B - 2e = 30 - 2(8.970) = 12.060 \text{ ft (Figure 5-1a)}$$

$$\gamma' = 0.0775 \text{ kcf, } D = 6 \text{ ft}$$

$$q_o = \gamma' D = 0.0775(6 \text{ ft}) = 0.465 \text{ ksf} \quad [5-8a]$$

$$\xi_{cd} = 1 + 0.2(D/\bar{B}) \tan \left(45^\circ + \frac{\phi}{2} \right) \quad [5-4a]$$

$$\xi_{cd} = 1 + 0.2(0.4975)(2.1445) = 1.213$$

$$\xi_{qd} = \xi_{\gamma d} = 1 + 0.1(D/\bar{B}) \tan \left(45 + \frac{\phi}{2} \right) = 1.107 \quad [5-4c]$$

$$\xi_{qi} = \xi_{ci} = \left(1 - \frac{\delta}{90} \right)^2 = \left(1 - \frac{22.87}{90} \right)^2 = 0.5564 \quad [5-5a]$$

$$\xi_{\gamma i} = \left(1 - \frac{\delta}{\phi} \right)^2 = \left(1 - \frac{22.87}{40} \right)^2 = 0.1834 \quad [5-5b]$$

$$N_c = 75.31, \quad N_q = 64.20, \quad N_\gamma = 93.69 \quad (\text{Table 5-1})$$

From Equation 5-2

$$Q = \bar{B} \left(\xi_{cd} \xi_{ci} c N_c + \xi_{qd} \xi_{qi} q_o N_q + \frac{\xi_{\gamma d} \xi_{\gamma i} \bar{B} \gamma N_\gamma}{2} \right) \quad [5-2]$$

$$Q = 12.060 \left[1.213(0.5564)(2.5)(75.31) + 1.107(0.5564)(0.465)(64.2) + \frac{1.107(0.1834)(12.060)(0.0775)(93.69)}{2} \right]$$

$$Q = 1861.41 \text{ kips}$$

For this problem $\Sigma V = N'$. The FS is calculated using Equation 5-1.

$$FS = \frac{Q}{N'} = \frac{1861.41}{161.89} = 11.50 > 2.0 \quad (\text{Required by Table 4-1.})$$

Bearing criterion is satisfied.

a. Water pressures (line of creep, paragraph 3-19).

$$L_{CG} = \sqrt{4^2 + 20^2} = 20.40 \text{ ft}, \quad L_{BC} = 0, \quad \Delta_h = 9 \text{ ft}$$

$$L_{GH} = 5 \text{ ft}, \quad L_S = 20.4 \text{ ft} + 5 \text{ ft} = 25.4 \text{ ft}$$

$$u_C = \frac{\text{Dist. below Headwater}}{\text{Headwater}} - \frac{\Delta_h(L_{BC})}{L_S} \quad \gamma_w = \left(18 \text{ ft} - \frac{9 \times 0}{25.4}\right) 0.0625 = 1.125 \text{ ksf}$$

$$u_G = \frac{\text{Dist. below Headwater}}{\text{Headwater}} - \frac{\Delta_h(L_{CG})}{L_S} \quad \gamma_w = \left(14 \text{ ft} - \frac{9 \times 20.4}{25.4}\right) 0.0625 = 0.4232 \text{ ksf}$$

Compute water pressure at D and E. Prorate head loss along path CDEG. Total head loss along path

$$CG = \frac{9(20.4)}{25.4} = 7.228 \text{ ft}$$

$$L_S \text{ (Concrete surface)} = L_{CD} + L_{DE} + L_{EG}$$

$$L_S = 1.5 + 4.03 + 18 = 23.53 \text{ ft}$$

$$\text{Head loss at D} = \frac{1.5}{23.53} (7.228) = 0.4608 \text{ ft}$$

$$u_D = (18 - 0.4608)0.0625 = 1.0962 \text{ ksf}$$

$$\text{Head loss at E} = \frac{(1.5 + 4.03)}{23.53} (7.228) = 1.699 \text{ ft}$$

$$u_E = (14 - 1.699)0.0625 = 0.7688 \text{ ksf}$$

b. Overturning stability (paragraph 4-8).

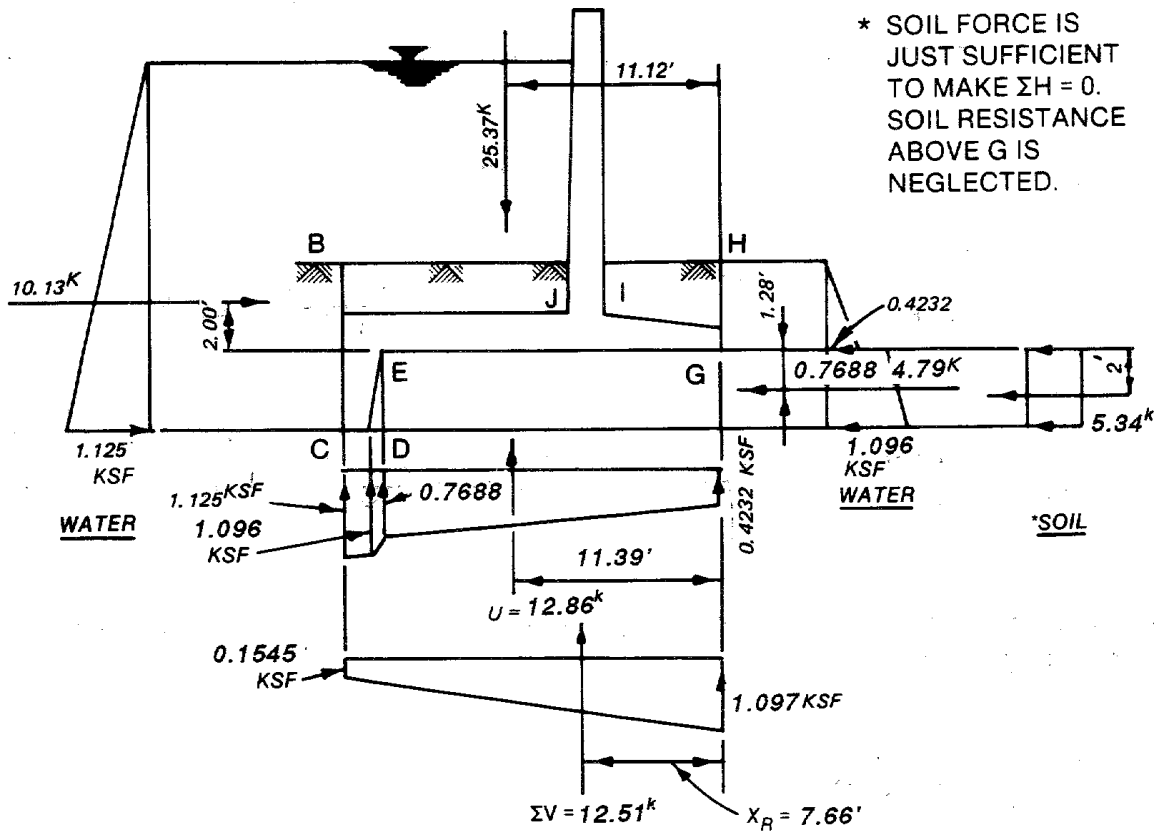

Overturning calculations

$$\begin{aligned}
 & 25.37 \text{ kips} \times 11.12 \text{ ft} = 282.11 \text{ ft-k} \\
 & -12.86 \text{ kips} \times 11.39 \text{ ft} = -146.48 \text{ ft-k} \\
 \Sigma V = & \underline{\underline{12.51 \text{ kips}}}
 \end{aligned}$$

$$\begin{aligned}
 & -10.13 \text{ kips} \times 2.00 \text{ ft} = -20.26 \text{ ft-k} \\
 & 4.79 \text{ kips} \times -1.28 \text{ ft} = -6.13 \text{ ft-k} \\
 & 5.34 \text{ kips} \times -2.00 \text{ ft} = -10.68 \text{ ft-k} \\
 \Sigma H = & \underline{\underline{0.00 \text{ kip}}} \qquad 98.56 \div 12.51 = \underline{\underline{7.87 \text{ ft}}} = x_R
 \end{aligned}$$

One hundred percent of base is in compression satisfying the requirements of Table 4-2.

c. Sliding stability analysis (paragraph 4-10).

(1) On Plane CG:

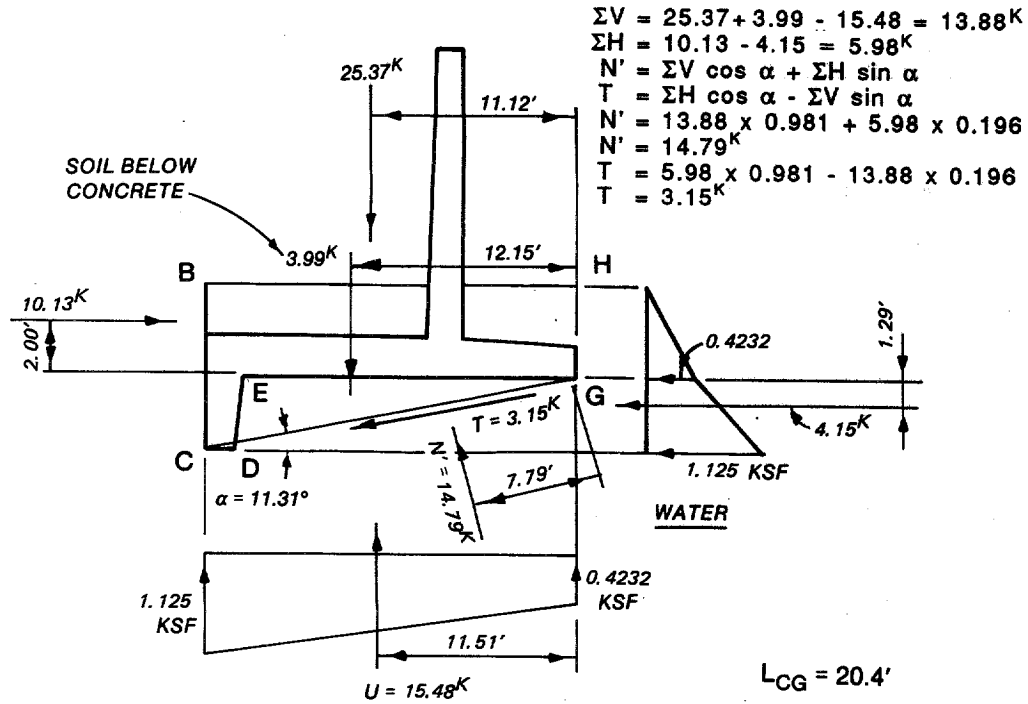

For undrained shear strength:

$$cL_{CG} = 0.9 \times 20.4 = 18.36 \text{ kips}$$

$$T \leq \frac{N' \tan \phi + cL}{FS}$$

[4-12]

From Table 4-2, the minimum FS is 1.5.

$$3.15 \leq \frac{18.36}{1.5}$$

$$3.15 \leq 12.24$$

$$\begin{aligned}\gamma' &= \text{effective weight on landside} = [9 \text{ ft}(0.12) - 0.7371] \div 9 \\ &= 0.0381 \text{ kcf}\end{aligned}$$

Undrained condition,

$$c = 0.9 \text{ ksf}$$

$$c_d = \text{SMF}(c) \quad [3-10]$$

$$c_d = \frac{2}{3} (0.9) = 0.6 \text{ ksf}$$

$$K_o = 1.0 \quad (\text{from Equation 3-4})$$

The at-rest earth force may be calculated as:

$$P_R = \frac{1}{2} \gamma_b h^2 = \frac{1}{2} (0.0381)(9)^2 = 1.54 \text{ kips}$$

$$c_d L_{CF} = 0.6(20) = 12 \text{ kips}$$

$$T \leq \frac{N' \tan \phi + cL}{FS} \quad [4-12]$$

Using the minimum FS of 1.5 from Table 4-2 yields

$$T = \Sigma H = 6.82 - 1.54 = 5.28 \text{ kips}$$

$$5.28 \leq \frac{12}{1.5}$$

$$5.28 \leq 8$$

Sliding resistance is adequate.

Drained condition,

$$\phi = 28^\circ$$

$$SMF = \frac{\tan \phi_d}{\tan \phi} = \frac{2}{3} \quad [3-10]$$

$$\phi_d = \tan^{-1} \left(\frac{2}{3} \tan \phi \right) = 19.52^\circ$$

$$K_p = \tan^2 \left(45^\circ + \frac{\phi}{2} \right) = 2.77$$

Let $K = 1/2 K_p = 1.385$ (Paragraph 3-8b)

$$P_R = \frac{1}{2} K \gamma_b h^2 = \frac{1}{2} (1.385)(0.0381)(9)^2 = 2.14 \text{ kips}$$

$$N' = \Sigma V = 25.37 + 8.76 - 18.62 = 15.51$$

$$T = 10.13 - 3.31 - 2.14 = 4.68 \text{ kips}$$

$$T \leq \frac{N' \tan \phi + cL}{FS} \quad [4-12]$$

Using the minimum FS of 1.5 from Table 4-2 yields

$$4.68 \leq \frac{15.51 \tan 28^\circ}{1.5}$$

$$4.68 \leq 5.50$$

Sliding resistance is adequate.

d. Bearing capacity analysis (on Plane CG).

$$N' = 14.79 \text{ kips}$$

$$T = 3.15 \text{ kips}$$

$$\alpha = 11.31^\circ = 0.197 \text{ rad}$$

$$e = \frac{L_{CG}}{2} - a = \frac{20.4}{2} - 7.79 = 2.41$$

$$\bar{B} = L_{CG} - 2e = 15.58 \text{ ft}$$

$$\delta = \tan^{-1} \left(\frac{T}{N'} \right) = \tan^{-1} \left(\frac{3.15}{14.79} \right) = 12.02^\circ \quad (\text{Figure 5-1})$$

$$\gamma' = 0.120 - 0.0625 = 0.0575 \text{ kcf}$$

$$D = 5 \text{ ft}$$

$$q_o = \gamma' D = 0.0575(5) = 0.2875 \text{ ksf} \quad [5-8a]$$

$$\xi_{cd}(\phi = 0) = 1 + 0.2 \left(\frac{D}{\bar{B}} \right) = 1 + 0.2 \left(\frac{5}{15.58} \right) = 1.064 \quad [5-4a]$$

$$\xi_{qd} = \xi_{\gamma d} = 1 \quad (\text{for } \phi = 0^\circ) \quad [5-4b]$$

$$\xi_{qd} = \xi_{\gamma d} = 1 + 0.1 \left(\frac{D}{\bar{B}} \right) \tan \left(45^\circ + \frac{\phi}{2} \right) \quad (\text{for } \phi = 28^\circ) \quad [5-4c]$$

$$\xi_{qd} = \xi_{\gamma d} = 1 + 0.1 \left(\frac{5}{15.58} \right) (1.6643) = 1.053 \quad (\phi = 28^\circ)$$

$$\xi_{qi} = \xi_{ci} = \left(1 - \frac{\delta}{90} \right)^2 = \left(1 - \frac{12.02}{90} \right)^2 = 0.7507 \quad [5-5a]$$

$$\xi_{\gamma i} = \left(1 - \frac{12.02}{28} \right)^2 = 0.3257 \quad [5-5b]$$

$$\xi_{qt} = \xi_{\gamma t} = (1 - \alpha \tan \phi)^2 = (1 - 0.197 \times 0.532)^2 = 0.8015 \quad [5-6a]$$

$$\xi_{ct} = 1 - \left(\frac{2\alpha}{\pi + 2}\right) = 1 - \left(\frac{0.394}{\pi + 2}\right) = 0.9232 \quad (\text{for } \phi = 0) \quad [5-6b]$$

Undrained condition:

$$c = 0.9 \text{ ksf}$$

From Equation 5-2

$$Q = \bar{B} \left(\xi_{cd} \xi_{ci} \xi_{ct} c N_c + \xi_{qd} \xi_{qi} \xi_{qt} q_o N_q \right)$$

$$N_c = 5.14, \quad N_q = 1.00 \quad (\text{Table 5-1})$$

$$Q = 15.58 \left[1.064(0.7507)(0.9232)(5.14)(0.9) + 1(0.7507)(0.8015)(0.2875)(1) \right]$$

$$Q^l = 55.84 \text{ kips}, \quad FS = \frac{Q}{N^l} = \frac{55.84}{14.79} = 3.78 > 3.00 \quad (\text{Table 4-2})$$

Drained condition:

$$\phi = 28^\circ$$

$$Q = \bar{B} \left(\xi_{qd} \xi_{qi} \xi_{qt} q_o N_q + \frac{\xi_{\gamma d} \xi_{\gamma i} \xi_{\gamma t} \bar{B} N_\gamma}{2} \right)$$

$$N_q = 14.72, \quad N_\gamma = 11.19 \quad (\text{Table 5-1})$$

$$Q = 15.58 \left[1.053(0.7507)(0.8015)(0.2875)(14.72) + \frac{1.053(0.3257)(0.8015)(15.58)(0.0575)(11.19)}{2} \right] = 63.24 \text{ kips}$$

$$FS = \frac{Q}{N'} = \frac{63.24}{14.79} = 4.28 > 3.00 \quad (\text{Table 4-1})$$

Bearing capacity is adequate.

e. Reinforcement (Chapter 9).

$$f'_c = 3 \text{ ksi}, \quad f_y = 40 \text{ ksi}, \quad \text{cover} = 4.5 \text{ in.}$$

(1) At base of stem:

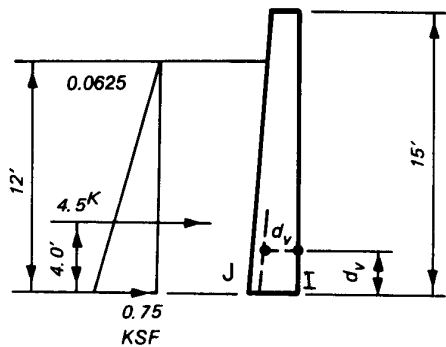

$$M = 4.5 \times 4 = 18.00 \text{ k-ft}$$

$$\frac{M_u}{\phi} = \frac{1.9(18.00)12}{0.9} = 456.0 \text{ k-in.}$$

$$d = 24 \text{ in.} - 4.5 \text{ in.} = 19.5 \text{ in.},$$

$$b = 12 \text{ in.}$$

$$k_u = 1 - \sqrt{1 - \frac{M_u/\phi}{0.425f'_c b d^2}} \quad (\text{Figure 9-2})$$

$$k_u = 1 - \sqrt{1 - \frac{456.0}{5817.825}} = 0.0400$$

$$C_u = T_u = 0.85f'_c k_u b d = 0.85(3)(0.040)(12)(19.5) = 23.87 \text{ kips}$$

$$A_s = \frac{T_u}{f_y} = \frac{23.87}{40} = \underline{\underline{0.60 \text{ in.}^2/\text{ft}}}$$

Check ductility requirements:

$$\beta_1 = 0.85, \quad \epsilon_c = 0.003$$

$$\rho_b = \frac{0.85f'_c}{f_y} \beta_1 \left(\frac{\epsilon_c}{\epsilon_m + \frac{f_y}{29,000 \text{ ksi}}} \right) \quad (\text{see example 1, paragraph 1})$$

$$\rho_b = \frac{0.85(3)}{40} (0.85) \left(\frac{0.003}{0.003 + \frac{40}{29,000}} \right) = 0.03712$$

$$\rho_{\max} = \lambda \rho_b, \quad \lambda = 0.25 \text{ (paragraph 9-8c(2)(a))}$$

$$\rho_{\max} = 0.25(0.03712) = 0.00928$$

$$\rho_{\min} = 200/f_y = 200/40,000 \text{ ksi} = 0.005 \text{ (paragraph 9-8b(4), from ACI 318)}$$

$$\rho = \frac{A_s}{bd} = \frac{0.60}{12(19.5)} = 0.002564$$

$$\rho < \rho_{\min}$$

Instead of using ρ_{\min} , ACI 318 allows the minimum area of reinforcement to be one-third greater than that required by analysis. Therefore,

$$A_s = 4/3(0.60) = 0.80 \text{ in.}^2/\text{ft}$$

$$\rho = \frac{A_s}{bd} = \frac{0.80}{12(19.5)} = 0.00342$$

$$\rho = \rho_{\max}$$

Ductility is adequate.

(2) Check shear at distance d_v above base (paragraph 9-8f)

$$d_v = d - \left(\frac{0.5}{15}\right)d_v = 19.5 - 0.0333 d_v$$

$$d_v = \frac{19.5}{1.03333} = 18.87 \text{ in.} = 1.573 \text{ ft}$$

$$V = \frac{1}{2} (0.0625)(12 - 1.573)^2 = 3.40 \text{ kips}$$

$$V_u = 1.9 V = 1.9(3.40) = 6.46 \text{ kips} = 6,460 \text{ lb}$$

$$\phi V_c = \phi 2\sqrt{f'_c} b d_v \quad (\text{from ACI-318})$$

$$\phi V_c = 2(0.85)(\sqrt{3000})(12)(18.87) = 21,084 \text{ lb} > 6,460$$

Shear capacity is adequate. Shear is most critical for stem.

(3) Toe at face of stem (Figure 9-2):

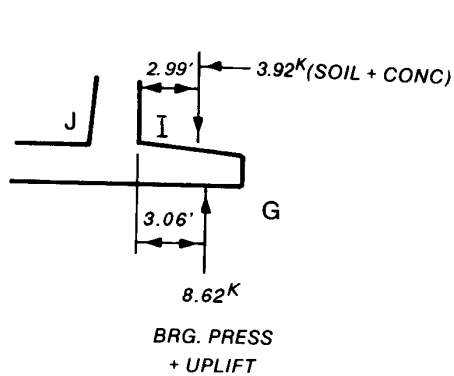

$$V_I = \frac{8.62 \times 3.06 - 3.92 \times 2.99}{4.70} \text{ kips} \quad M = \frac{26.38 - 11.72}{14.66} \text{ k-ft}$$

$$b = 12 \text{ in.}, \quad d = 19.5 \text{ in.}$$

$$0.425 f'_c b d^2 = 5817.825$$

$$\frac{M_u}{\phi} = \frac{1.9(14.66)(12)}{0.9} = 371.39 \text{ k-in.}$$

$$k_u = 1 - \sqrt{1 - \frac{371.39}{5817.825}} = 0.03244$$

$$C_u = T_u = 0.85(3)(0.03244)(12)(19.5) = 19.36 \text{ kips}$$

$$A_s = \frac{T_u}{f_y} = \frac{19.36}{40} = \underline{\underline{0.48 \text{ in.}^2/\text{ft}}}$$

Check ductility:

$$\rho_{\max} = 0.00928, \quad \rho_{\min} = 0.005$$

$$\rho = \frac{A_s}{bd} = \frac{0.48}{12(19.5)} = 0.00205$$

$$d - \frac{h}{2} = 19.5 - \frac{24}{2} = 7.5$$

$$\frac{M_u}{P_u} < d - \frac{h}{2} \quad \text{Therefore, the conditions of Figure 9-5 apply.}$$

$$\begin{aligned} M_{ue} &= -M_u + P_u \left(d - \frac{h}{2} \right) \\ &= -20.52 + 6.54(7.5) \\ &= 28.53 \text{ in.-k} \end{aligned}$$

$$A'_s = \frac{M_{ue}}{\phi f_y (d - d')} = \frac{28.53}{0.9(40)(19.5 - 4.5)} = 0.053 \text{ in.}^2/\text{ft}$$

$$A_s = \frac{\frac{P_u}{\phi} - f_y A'_s}{f_y} = \frac{\frac{6.54}{0.9} - 40(0.053)}{40} = 0.13 \text{ in.}^2/\text{ft}$$

Reinforcement at "0" neglecting 5.34 kips force on key (Figure 9-3)

$$M_o = 0.90 + 5.34(3.00) = 16.92 \text{ ft-k} = 203.04 \text{ in.-k}$$

$$M_u = 1.9M_o = 385.78 \text{ in.-k}$$

$$P = 1.9 \text{ kips (compression)}$$

$$P_u = 1.9P = 1.9(1.9) = 3.61 \text{ kips}$$

$$\begin{aligned} \phi &= 0.9 - \frac{P_u}{0.1f'_c b h} \quad (0.2) \\ &= 0.9 - \frac{3.61}{0.1(3)(12)(19.5)} \quad (0.2) \\ &= 0.89 \end{aligned}$$

$$\begin{aligned}M_{ue} &= M_u + P_u \left(d - \frac{h}{2} \right) \\&= 385.78 + 3.61 \left(19.5 - \frac{24}{2} \right) \\&= 412.86 \text{ in.-k}\end{aligned}$$

$$\begin{aligned}k_u &= 1 - \sqrt{1 - \frac{M_{ue}}{\phi 0.425 f'_c b d^2}} \\&= 1 - \sqrt{1 - \frac{412.86}{0.89(5817.825)}} \\&= 0.04070\end{aligned}$$

$$\begin{aligned}A_s &= \frac{0.85 f'_c k_u b d - \frac{P_u}{\phi}}{f_y} \\&= \frac{0.85(3)(0.04070)(12)(19.5) - \frac{3.61}{0.89}}{40} \\&= 0.51 \text{ in.}^2\text{ft}\end{aligned}$$

Check ductility:

$$\rho_{\max} = 0.00928, \quad \rho_{\min} = 0.005$$

$$\rho = \frac{A_s}{b d} = \frac{0.51}{12(19.5)} = 0.00218$$

$$\rho < \rho_{\min}$$

$$\text{Use } A_s = 4/3(0.51) = 0.68 \text{ in.}^2/\text{ft}$$

$$\rho = \frac{A_s}{bd} = \frac{0.68}{12(19.5)} = 0.00291$$

$$\rho < \rho_{\max}$$

Ductility is adequate.

Reinforcement in key at "E" (Figure 9-2):

$$M = 5.34(2) + 3.73(2.12) - 4.00(2.08) = 10.27 \text{ ft-k}$$

$$\frac{M_u}{\phi} = \frac{1.9(10.27)(12)}{0.9} = 260.11 \text{ k-in.}$$

$$k_u = 1 - \sqrt{1 - \frac{260.11}{5817.825}} = 0.02261$$

$$C_u = T_u = 0.85(3)(0.02261)(12)(19.5) = 13.49 \text{ kips}$$

$$A_s = \frac{T_u}{f_y} = \frac{13.49}{40} = \underline{\underline{0.34 \text{ in.}^2/\text{ft}}}$$

Check ductility:

$$\rho_{\max} = 0.00928, \quad \rho_{\min} = 0.005$$

$$\rho = \frac{A_s}{bd} = \frac{0.34}{12(19.5)} = 0.00145$$

$$\rho < \rho_{\min}$$

$$\text{Use } A_s = 4/3(0.34) = 0.45 \text{ in.}^2/\text{ft}$$

$$\rho = \frac{A_s}{bd} = \frac{0.45}{12(19.5)} = 0.00194$$

$$\rho < \rho_{\max}$$

Ductility is adequate.

N-4. EXAMPLE 4.

Analyze the wall for overturning, sliding and bearing capacity. Use the line of creep method to determine water pressures. Load Case I1, Design Flood. Calculate reinforcement at critical sections.

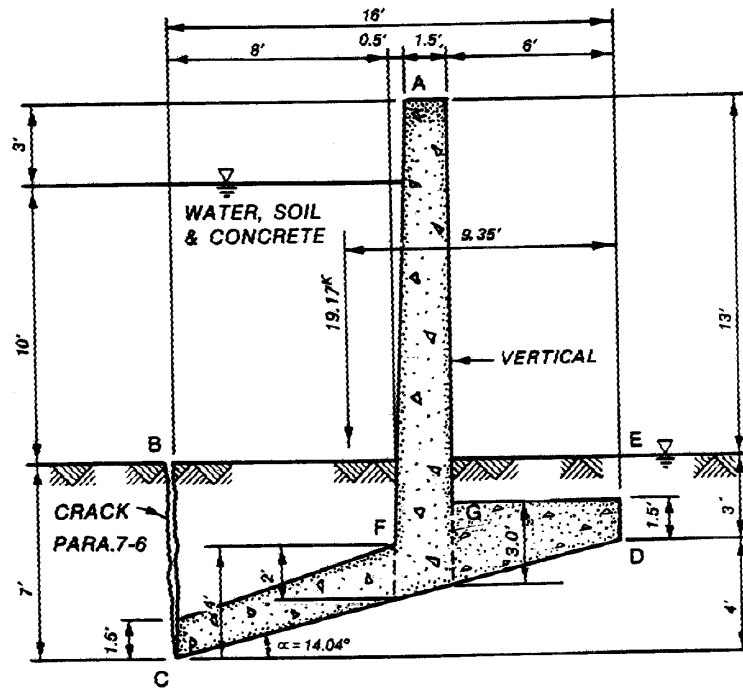

$\gamma_{SAT} = 0.12 \text{ KCF}$
 $\phi = 0$
 $c = 0.9 \text{ KSF}$

a. Water pressures (paragraph 3-19).

$$u_C = 17(0.0625) = 1.0625 \text{ ksf}$$

$$\Delta_h = 10 \text{ ft}$$

$$L_{CD} = 16.49 \text{ ft}$$

$$L_{DE} = 3 \text{ ft}$$

$$L_S = L_{CD} + L_{DE} = 19.49 \text{ ft}$$

$$U_D = \left(13 - \frac{10 \times 16.49}{19.49}\right) 0.0625 = 0.2837 \text{ ksf}$$

b. Overtuning stability.

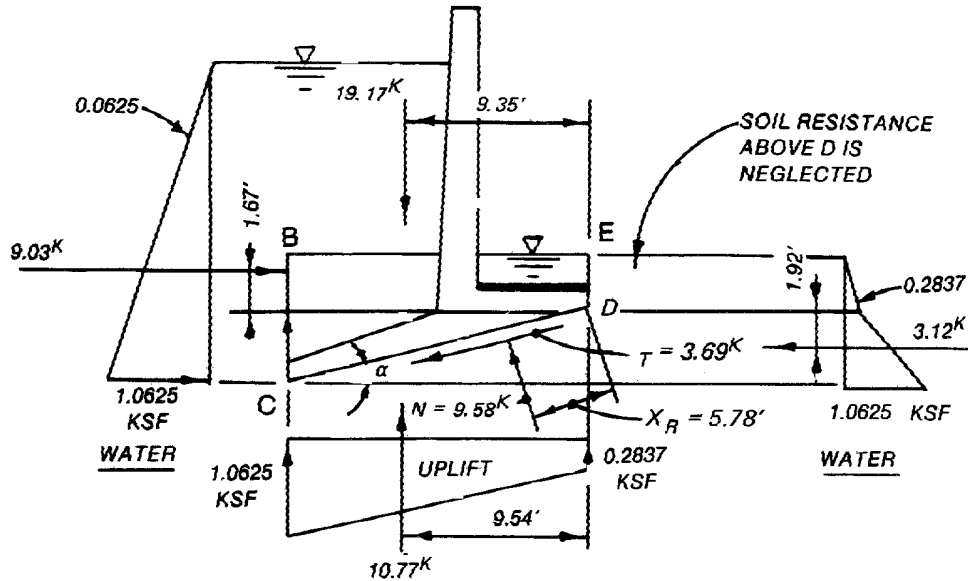

$$\begin{aligned} 19.17 \times 9.35 &= 179.24 \\ -10.77 \times 9.54 &= -102.75 \\ \hline 8.40 \text{ kips} &= \Sigma V \\ -9.03 \times 1.67 &= -15.08 \\ 3.12 \times -1.92 &= -5.99 \\ \hline -5.91 \text{ kips} & \\ \hline \hline 55.42 \text{ k-ft} &= M_D \end{aligned}$$

$$\begin{aligned} N' &= \Sigma V \cos \alpha + \Sigma H \sin \alpha \\ T &= \Sigma H \cos \alpha - \Sigma V \sin \alpha \\ N' &= 8.40(0.970) + 5.91(0.243) \\ N' &= 9.58 \text{ kips} \\ T &= 5.91(0.97) - 8.40(0.243) \\ T &= 3.69 \text{ kips} \end{aligned}$$

$$x_R = \frac{M_D}{N'} = \frac{55.42}{9.58} = 5.78 \text{ ft} > \frac{L_{CD}}{3} = \frac{16.49}{3} = 5.50 \text{ ft}$$

One hundred percent of Surface CD is in compression (Table 4-2). Overturning criterion is satisfied.

c. Sliding stability (paragraph 4-15).

On Surface CD:

$$N' = 9.58 \text{ kips}, \quad T = 3.69 \text{ kips}, \quad \alpha = 14.04^\circ, \quad \phi = 0, \quad c = 0.9 \text{ ksf}$$

$$L_{CD} = 16.49 \text{ ft}$$

$$T \leq \frac{N' \tan \phi + cL}{FS} \quad [4-12]$$

Using the minimum required FS of 1.5, as given in Table 4-2, yields

$$3.69 \leq \frac{9.58 \tan 0^\circ + 0.9(16.49)}{1.5}$$

$$3.69 \leq 9.89$$

Sliding criterion is satisfied.

d. Bearing capacity analysis.

$$\alpha = 14.04^\circ$$

$$\alpha = 0.245 \text{ rad}$$

$$\delta = \tan^{-1} \left(\frac{T}{N'} \right) = \tan^{-1} \frac{3.69}{9.58} = 21.07^\circ$$

$$e = \frac{L_{CD}}{2} - x_R = \frac{16.49}{2} - 5.78 = 2.465 \text{ ft}$$

$$\bar{B} = L_{CD} - 2e = 16.49 - 2(2.465) = 11.56 \text{ ft (Figure 5-1b)}$$

$$\gamma' = \gamma_{sat} - \gamma_w = 0.120 - 0.0625 = 0.0575 \text{ kcf}$$

$$q_o = \gamma'_D = 0.0575(3) = 0.1725 \text{ ksf} \quad [5-8a]$$

$$\xi_{cd} = 1 + 0.2\left(\frac{D}{B}\right) = 1 + 0.2\left(\frac{3}{11.56}\right) = 1.05 \quad [5-4a]$$

$$\xi_{\gamma d} = \xi_{qd} = 1.00 \quad [5-4b]$$

$$\xi_{ci} = \xi_{qi} = \left(1 - \frac{\delta}{90}\right)^2 = \left(1 - \frac{21.07}{90}\right)^2 = 0.587 \quad [5-5a]$$

$$\xi_{\gamma i} = 0 \quad [5-5b]$$

$$\xi_{qt} = \xi_{\gamma t} = 1 \quad [5-6a]$$

$$\xi_{ct} = 1 - \left(\frac{2\alpha}{\pi + 2}\right) = 1 - \left(\frac{2 \times 0.245}{5.14}\right) = 0.905 \quad [5-6b]$$

$$N_c = 5.14, \quad N_q = 1, \quad N_\gamma = 0 \text{ (Table 5-1)}$$

$$\xi_{\gamma g} = \xi_{qg} = [1 - \tan(\beta)]^2 = [1 - \tan(0)]^2 = 1 \quad [5-7a]$$

$$\xi_{cg} = 1 - \frac{2(\beta)}{(\pi + 2)} = 1 - \frac{2(0)}{(\pi + 2)} = 1 \quad [5-7b]$$

$$Q = \bar{B} \left[(\xi_{cd} \xi_{ci} \xi_{ct} \xi_{cg} c N_c) + (\xi_{qd} \xi_{qi} \xi_{qt} \xi_{qg} q_o N_q) + \frac{(\xi_{\gamma d} \xi_{\gamma i} \xi_{\gamma t} \xi_{\gamma g} \bar{B} N_\gamma)}{2} \right] \quad [5-2]$$

$$= 11.56 \left[(1.05)(0.587)(0.905)(1)(0.9)(5.14) + (1)(0.587)(1)(1)(0.1725)(1) + \frac{(1)(0)(1)(1)(11.56)(0.0575)(0)}{2} \right] = 31.00 \text{ kips}$$

$$FS = \frac{Q}{N'} = \frac{31.00}{9.58} = 3.24 \quad [5-1]$$

3.24 > 3.0 , so bearing criterion is satisfied (Table 4-2)

e. Reinforcement (Chapter 9).

$f'_c = 3$ ksi, $f_y = 40$ ksi, load factor = 1.9 , $\phi = 0.9$,
cover = 4.5 in.

(1) At base of stem (Figure 9-2): $b = 12$ in., $h = 23.44$ in.,
 $d = 23.44 - 4.5 = 18.94$ in.

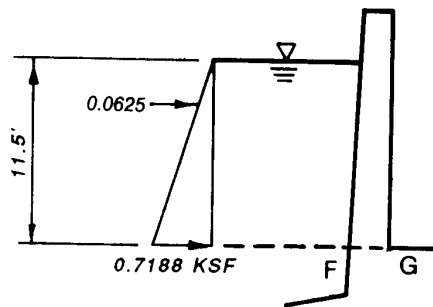

$$M = 0.0625(11.5) \left(\frac{11.5}{2} \right) \left(\frac{11.5}{3} \right)$$

$$M = 0.0625(11.5)^3 \frac{1}{6} = 15.84 \text{ ft-k}$$

$$\frac{M_u}{\phi} = \frac{1.9(15.84)(12)}{0.9} = 401.28 \text{ k-in.}$$

$$0.425f'_c b d^2 = 5488.471$$

$$k_u = 1 - \sqrt{1 - \frac{401.28}{5488.471}} = 0.03725$$

$$C_u = T_u = 0.85f'_c k_u b d$$

$$C_u = T_u = 21.59 \text{ kips}$$

$$A_s = \frac{T_u}{f_y} = \frac{21.59}{40} = \underline{\underline{0.54 \text{ in.}^2/\text{ft}}}$$

For shear check see Example 1 and 3, Appendix N.

Check ductility and concrete section strength: calculate ρ_b for
 $\epsilon_c = 0.003$, $f_y = 40$ ksi, $f'_c = 3$ ksi, $\beta_1 = 0.85$.

$$\begin{aligned}\rho_b &= \frac{0.85f'_c\beta_1}{f_y} \left(\frac{\epsilon_c}{\frac{\epsilon_1 + f_y}{29,000 \text{ ksi}}} \right) \quad (\text{See Example 1 for derivation of } \rho_b) \\ &= \frac{0.85(3)(0.85)}{40} \left(\frac{0.003}{0.003 + \frac{40}{29,000}} \right) \\ &= 0.03712\end{aligned}$$

$$\rho_{\max} = 0.25 \rho_b = 0.00928$$

$$\rho_{\min} = 200/f_y = 200/40,000 = 0.005 \quad (\text{paragraph 9-8b(4), from ACI 318})$$

$$\rho_{\text{actual}} = \frac{A_s}{bd} = \frac{0.54}{12(18.94)} = 0.00238$$

Since $\rho < \rho_{\min}$, use a one-third increase in the required area of reinforcement (from ACI 318).

$$A_s = 4/3(0.54) = 0.72 \text{ in.}^2/\text{ft}$$

$$\rho = \frac{A_s}{bd} = \frac{0.72}{12(18.94)} = 0.00317$$

$$\rho < \rho_{\max}$$

Ductility is adequate.

(2) In toe at stem (Chapter 9, Figure 9-3): $b = 12 \text{ in.}$, $d = 36 - 4.5 = 31.5 \text{ in.}$

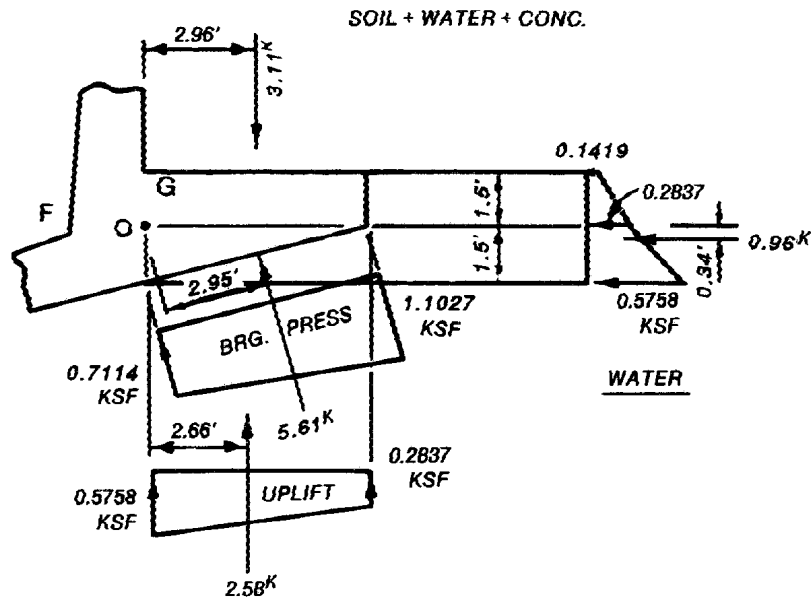

$$\begin{aligned}
 2.58(2.66) &= 6.863 \\
 5.61(2.95) &= 16.550 \\
 -3.11(2.96) &= -9.206 \\
 0.96(-0.34) &= -0.326 \\
 M_o &= 13.881 \text{ k-ft}
 \end{aligned}$$

$$P_o = 0.96 + 5.61 \sin 14.04^\circ = 2.32 \text{ kips}$$

$$M_u = 1.9(13.881) = 26.37 \text{ ft-k} = 316.44 \text{ in.-k}$$

$$P_u = 1.9(2.32) = 4.41 \text{ kips}$$

$$M_{ue} = M_u + P_u \left(d - \frac{h}{2} \right) = 316.44 + 4.41 \left(31.5 - \frac{36}{2} \right) = 375.98 \text{ in.-k}$$

$$\frac{M_{ue}}{\phi} = \frac{375.98}{0.9} = 417.75 \text{ in.-k}$$

$$0.425f'_c b d^2 = 0.425(3)(12)(31.5)^2 = 15,181.425$$

$$k_u = 1 - \sqrt{1 - \frac{M_{ue}}{\phi} \frac{1}{0.425f'_c b d^2}} = 1 - \sqrt{1 - \frac{417.75}{15,181.425}}$$
$$= 0.01385$$

$$C_u = 0.85f'_c k_u b d = 0.85(3)(0.01385)(12)(31.5)$$

$$C_u = 13.35 \text{ kips} = T_u$$

$$A_s = \frac{T_u}{f_y} = \frac{13.35}{40} = 0.33 \text{ in.}^2/\text{ft}$$

$$\rho = \frac{0.33}{12(31.5)} = 0.000873 < \rho_{\max} = 0.00928$$

Since $\rho < \rho_{\min}$, use a one-third increase in the area of reinforcement (from ACI 318).

$$A_s = 4/3(0.33) = 0.44 \text{ in.}^2/\text{ft}$$

$$\begin{aligned}\phi &= 0.9 - \frac{P_u}{0.1f'_c b h} \quad (0.2) \\ &= 0.9 - \frac{2.6}{0.1(3)(12)(24)} \quad (0.2) \\ &= 0.89\end{aligned}$$

$$\frac{M_{ue}}{\phi} = \frac{201.42}{0.89} = 226.31 \text{ in.-k}$$

Check d_{\min} from Equation 9-13:

$$\rho_{\max} = 0.25\rho_b = 0.00928$$

$$k_m = \frac{f_y \rho_{\max}}{0.85f'_c} = \frac{40,000(0.00928)}{0.85(3000)} = 0.14557$$

$$\begin{aligned}d_{\min} &= \sqrt{\frac{\frac{M_u}{\phi}}{0.85f'_c k_m b \left(1 - \frac{k_m}{2}\right)}} \\ &= \sqrt{\frac{226.31}{0.85(3)(0.14557)(12) \left(1 - \frac{0.14557}{2}\right)}} \\ &= 7.40 \text{ in.}\end{aligned}$$

This is an approximate value of d_{\min} because Equation 9-13 is valid only for flexure.

$$h_{\min} = 7.40 + 4.5 = 11.9 \text{ in.}$$

The heel could have a constant thickness of 12 inches if desired. The steel will be sized for a $d = 19.5$ inches.

$$k_u = 1 - \sqrt{1 - \frac{M_{ue}}{\phi 0.425 f'_c b d^2}}$$

$$= 1 - \sqrt{1 - \frac{226.31}{5817.825}}$$

$$= 0.01964$$

$$A_s = \frac{0.85 f'_c k_u b d - \frac{P_u}{\phi}}{f_y}$$

$$= \frac{0.85(3)(0.01964)(12)(19.5) - \frac{2.60}{0.89}}{40}$$

$$= 0.22 \text{ in.}^2/\text{ft}$$

$$\rho = \frac{A_s}{bd} = \frac{0.22}{12(19.5)} = 0.0009402 < \rho_{\min} = 0.005$$

Since $\rho < \rho_{\min}$, use a one-third increase in the area of reinforcement.

$$A_s = 4/3(0.22) = 0.29 \text{ in.}^2/\text{ft}$$

N-5. EXAMPLE 5. Analyze the wall for overturning, sliding and bearing capacity. Determine water pressure using the line of creep method. Load Case I2.

Assume that sheet pile cutoff wall is 50 percent effective.

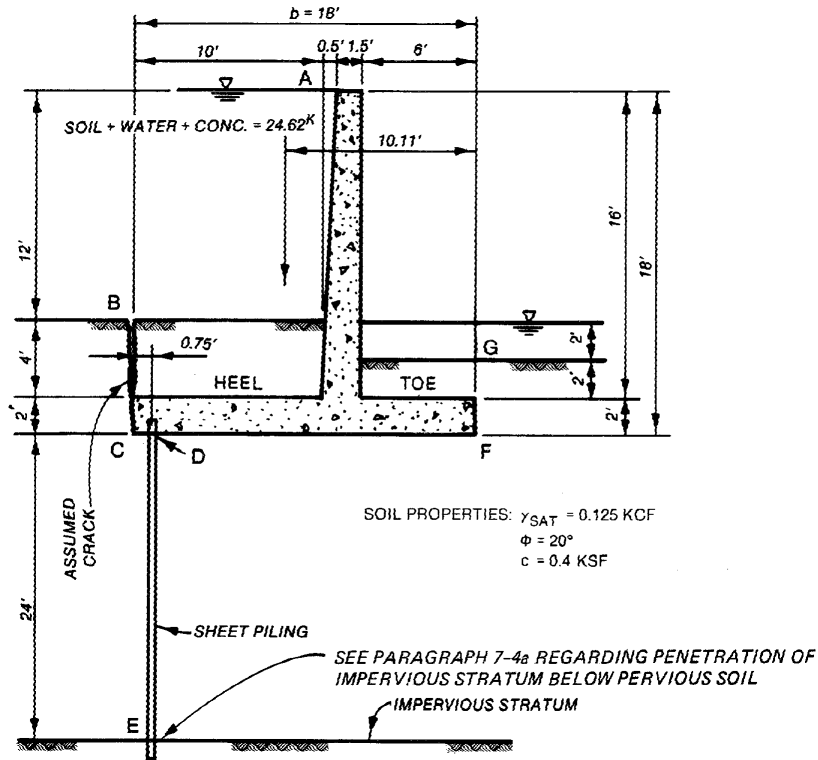

a. Water pressure with steel sheet pile cutoff wall. Reference: Paragraph 7-4a.

Full-head pressure on headwater side of sheet pile at point C

$$= (18 \text{ ft})(0.0625 \text{ pcf}) = 1.125 \text{ ksf}$$

Pressure at point F, based on seepage path from cutoff wall (point D) to point G:

$$= \left(\begin{array}{l} \text{pressure} \\ \text{head at F} \\ \text{due to position} \end{array} + \text{total head differential} \times \frac{FG}{DFG} \right) (0.0625)$$

$$= \left(6.0 + 12.0 \frac{4}{21.25} \right) (0.0625) = 0.516 \text{ ksf at point F}$$

Pressure on tailwater side of sheet pile at point D

$$= \text{full-head pressure at D} - 50\% (\text{full-head pressure at D} - \text{pressure at point F})$$

$$= 1.125 - 0.5(1.125 - 0.516) = 0.821 \text{ ksf}$$

b. Lateral soil force. Resisting side:

$$\gamma' = \left[2 \text{ ft}(\text{weight of water}) + 4(\text{weight of saturated earth}) \right. \\ \left. - \text{Seepage at F} \right] \div 4$$

$$= \left[2(0.0625) + 4(0.125) - 0.516 \right] \div 4$$

$$= 0.0273 \text{ kcf average, point G to point F}$$

$$K_o = 1 - \sin \phi = 1 - 0.342 = 0.658 \quad [3-4]$$

$$P_o = \frac{1}{2} K_o \gamma_b h^2 = \frac{1}{2} (0.658)(0.0273)(4)^2 = 0.1437 \text{ kips}$$

c. Overturning (paragraph 4-8).

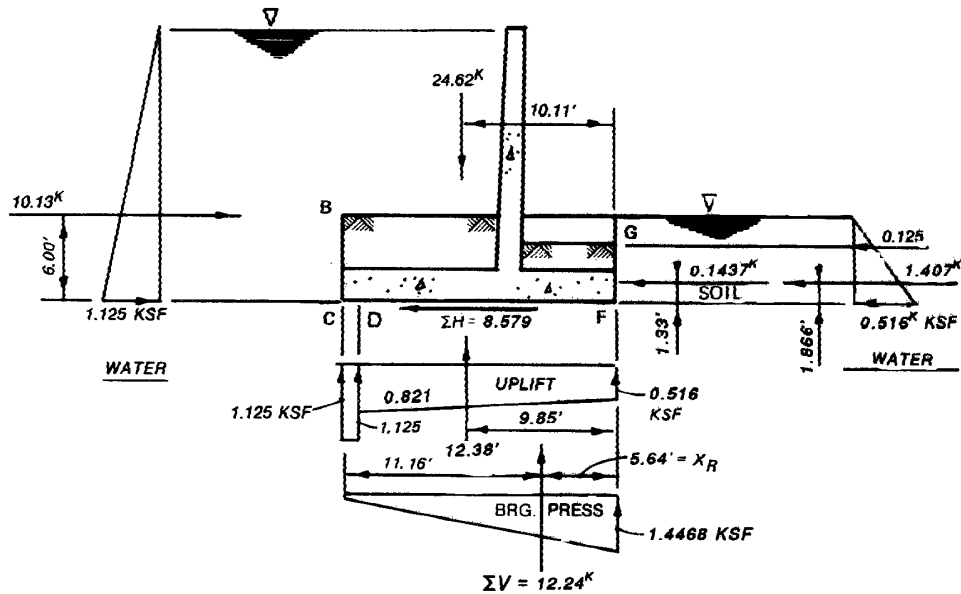

$$\begin{aligned} 24.62 \times 10.11 &= 248.91 \\ -12.38 \times 9.85 &= -121.94 \\ \Sigma V &= \underline{12.24 \text{ kips}} \end{aligned}$$

$$\begin{aligned} -10.13 \times 6.00 &= -60.78 \\ 0.14 \times 1.33 &= 0.19 \\ 1.41 \times 1.87 &= 2.64 \\ \Sigma H &= \underline{-8.57 \text{ kips}} \quad \frac{69.02}{12.24} = 5.64 \text{ ft} = x_R \end{aligned}$$

$$a = 3x_R = 3(5.64) = 16.92 \text{ ft} < 18.00 \text{ ft} = b$$

$$\text{Percent of base in compression} = \left(\frac{a}{b}\right)(100) = \left(\frac{16.92}{18}\right)100 = 94\% > 75\% \text{ (Table 4-2)}$$

Criterion is satisfied.

d. Sliding stability (FS = 1.33 required by Table 4-2, paragraph 4-15).

$$N' = \Sigma V = 12.24 \text{ kips}, \quad T = \Sigma H = 8.58 \text{ kips}$$

$$T \leq \frac{N' \tan \phi + cL}{FS} \quad [4-12]$$

Using the minimum required FS of 1.33 from Table 4-2 yields

$$8.58 \leq \frac{12.24 \tan 20^\circ + 0.4(16.92)}{1.33}$$

$$8.58 \leq 11.22$$

Sliding criterion is satisfied.

e. Bearing capacity (Chapter 5).

$$\delta = \tan^{-1} \left(\frac{\Sigma H}{\Sigma V} \right) = \tan^{-1} \left(\frac{8.58}{12.24} \right) = 35.03^\circ \text{ (Figure 5-1)}$$

$$e = \frac{B}{2} - x_R = \frac{18}{2} - 5.64 = 3.36 \text{ ft}$$

$$\bar{B} = B - 2e = 18 - 2(3.36) = 11.28 \text{ ft}$$

$$\gamma' = \gamma_b = 0.125 - 0.0625 = 0.0625, \quad D = 4 \text{ ft}$$

$$q_o = \gamma' D = 0.0625(4) = 0.25 \text{ ksf} \quad [5-8a]$$

$$\xi_{cd} = 1 + 0.2 \left(\frac{D}{\bar{B}} \right) \tan \left(45^\circ + \frac{\phi}{2} \right) = 1 + 0.2 \left(\frac{4}{11.28} \right) (1.428) = 1.101 \quad [5-4a]$$

$$\begin{aligned} \xi_{qd} = \xi_{\gamma d} &= 1 + 0.1 \left(\frac{D}{\bar{B}} \right) \tan \left(45 + \frac{\phi}{2} \right) \\ &= 1 + 0.1 \left(\frac{4}{11.28} \right) (1.428) = 1.051 \end{aligned} \quad [5-4c]$$

$$\xi_{qi} = \xi_{ci} = \left(1 - \frac{\delta}{90}\right)^2 = \left(1 - \frac{35.03}{90}\right)^2 = 0.373 \quad [5-5a]$$

$$\xi_{\gamma i} = 0, \quad \delta > \phi \quad [5-5b]$$

$$\xi_{\gamma g} = \xi_{qg} \left[1 - \tan(\beta)\right]^2 = \left[1 - \tan(0)\right]^2 = 1 \quad [5-7a]$$

$$\xi_{cg} = \xi_{qg} - \frac{1 - \xi_{qg}}{N_c \tan \phi} = 1 - \frac{1 - 1}{14.83 (\tan 20^\circ)} = 1 \quad [5-7d]$$

$$\xi_{qt} = \xi_{\gamma t} = (1 - \alpha \tan \phi)^2 = (1 - 0)^2 = 1 \quad [5-6a]$$

$$\xi_{ct} = \xi_{qt} - \frac{1 - \xi_{qt}}{N_c \tan \phi} = 1 - \frac{1 - 1}{14.83 (\tan 20^\circ)} = 1 \quad [5-6c]$$

$$N_c = 14.83, \quad N_q = 6.40, \quad N_\gamma = 2.87 \quad (\text{Table 5-1})$$

$$Q = \bar{B} \left[(\xi_{cd} \xi_{ci} \xi_{ct} \xi_{cg}^c N_c) + (\xi_{qd} \xi_{qi} \xi_{qt} \xi_{qg}^q N_q) + \frac{(\xi_{\gamma d} \xi_{\gamma i} \xi_{\gamma t} \xi_{\gamma g} \bar{B} N_\gamma)}{2} \right] \quad [5-2]$$

$$\begin{aligned} &= 11.28 \left[(1.101)(0.373)(1)(1)(0.4)(14.83) \right. \\ &\quad + 1.051(0.373)(1)(1)(0.25)(6.4) \\ &\quad \left. + 1.051(0)(1)(1)(11.28)(0.0625)(2.87)(1/2) \right] = 34.55 \text{ kips} \end{aligned}$$

$$N' = 12.24 \quad (\Sigma V \text{ for this problem})$$

$$FS = \frac{Q}{N'} = \frac{34.55}{12.24} = 2.82 > 2 \quad [5-1]$$

Bearing criterion is satisfied (Table 4-2)

N-6. EXAMPLE 6. Analyze the wall for overturning, sliding and bearing capacity. Use the line of creep method to determine water pressures. Load Case I1, design flood.

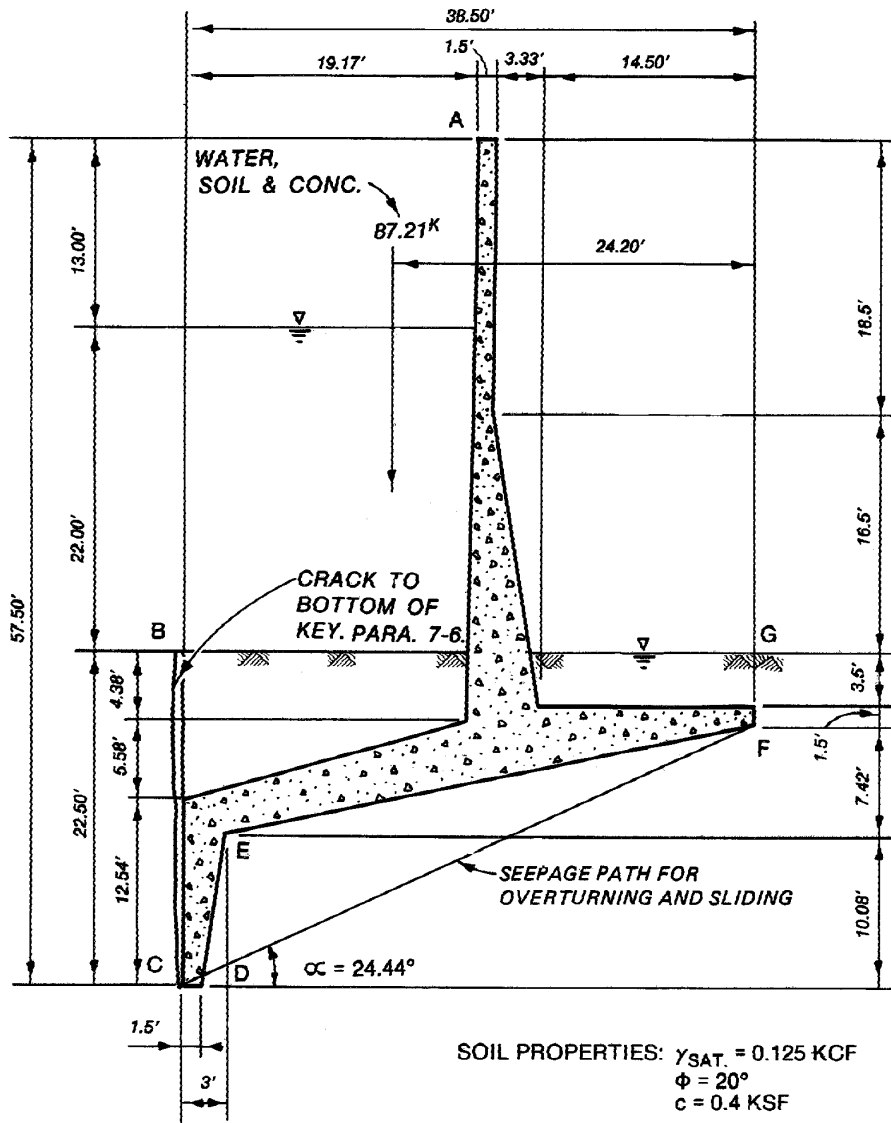

a. Water pressures (paragraph 3-19).

$$L_{CF} = \sqrt{(38.5)^2 + (17.5)^2} = 42.29 \text{ ft}, \quad L_{FG} = 5 \text{ ft}, \quad \Delta h = 22 \text{ ft}$$

$$L_S = L_{CF} + L_{FG} = 42.29 + 5 = 47.29 \text{ ft}$$

$$u_C = 44.5 (0.0625) = 2.7813 \text{ ksf}$$

$$u_F = \left(27 \text{ ft} - \frac{22 \times 42.29}{47.29} \right) 0.0625 = 0.4579 \text{ ksf}$$

Compute water pressure at D and E. Prorate head loss along path CDEF.

$$\text{Head loss along path CF} = \frac{42.29}{47.29} (22) = 19.674 \text{ ft}$$

$$L_S (\text{concrete surface}) = L_{CD} + L_{DE} + L_{EF}$$

$$L_S = 1.5 + 10.19 \text{ ft} + 36.27 \text{ ft} = 47.96 \text{ ft}$$

$$\text{Head loss at D} = \frac{1.5}{47.96} (19.674) = 0.6153 \text{ ft}$$

$$u_D = (44.5 - 0.6153)0.0625 = 2.743 \text{ ksf}$$

$$\text{Head loss at E} = \frac{(1.5 + 10.19)}{47.96} (19.674) = 4.795 \text{ ft}$$

$$u_E = (34.42 - 4.795)0.0625 = 1.852 \text{ ksf}$$

b. Lateral soil force (resisting side, above point F).

$$K_o = 1 - \sin \phi = 1 - 0.342 = 0.658 \quad [3-4]$$

$$\gamma' = [5 (0.125) - 0.4579] \div 5 = 0.0334 \text{ kcf}$$

$$P_o = \frac{1}{2} K_o \gamma_b h^2 = \frac{1}{2} (0.658) (0.0334) (5)^2 = \underline{\underline{0.275 \text{ kips}}}$$

c. Lateral water force (driving side).

$$h = 22.00 + 22.50 = 44.5 \text{ ft}, \quad \gamma_w = 0.0625 \text{ ksf}$$

$$P_w = \frac{1}{2} \gamma_w h^2 = \frac{1}{2} (0.0625)(44.5)^2 = \underline{\underline{61.88 \text{ kips}}}$$

d. Overtuning stability (paragraph 4-8, Figure 4-6).

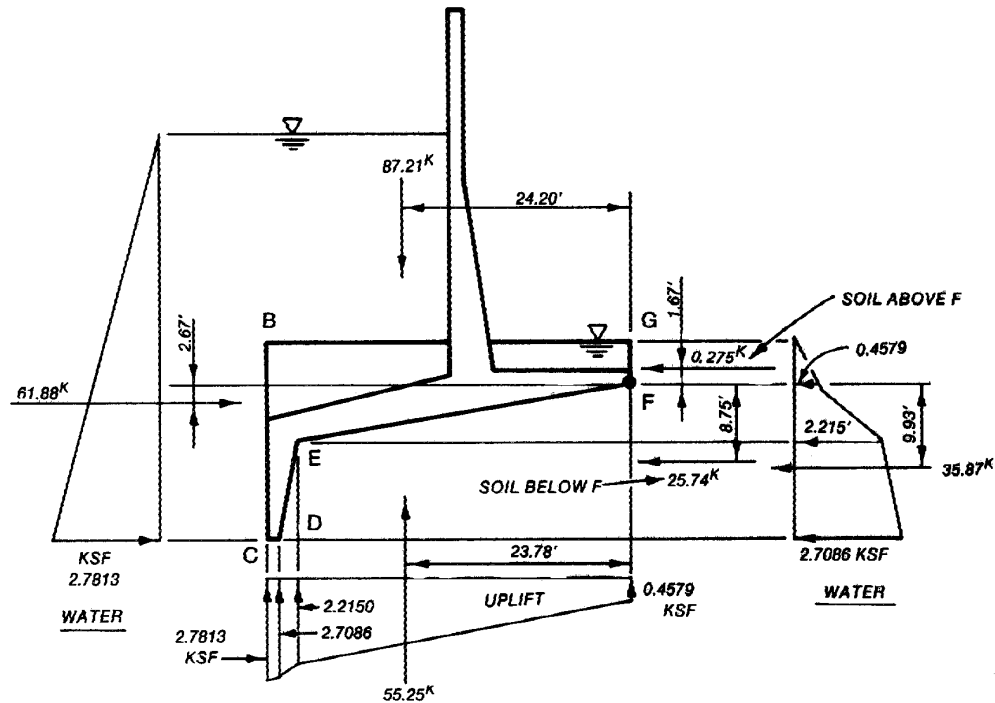

$$\begin{aligned} 87.21 \times 24.20 &= 2110.48 \\ -48.59 \times 23.78 &= -1155.47 \\ \underline{38.62} \times \Sigma V & \end{aligned}$$

$$x_R = \frac{536.88}{38.62} = \underline{\underline{13.90 \text{ ft}}} > \frac{b}{3}$$

$$\begin{aligned} -61.88 \times -2.67 &= 165.22 \\ 0.275 \times 1.67 &= 0.45 \\ 28.74 \times -8.75 &= -251.48 \\ \underline{32.87} \times -10.11 &= -332.32 \end{aligned}$$

$$\underline{\underline{0 = \Sigma H}} \quad M_F = 536.88 \text{ k-ft}$$

100 percent of base is in compression, overturning criteria satisfied (Table 4-2).

e. Sliding stability (on Plane CF, paragraph 4-15).

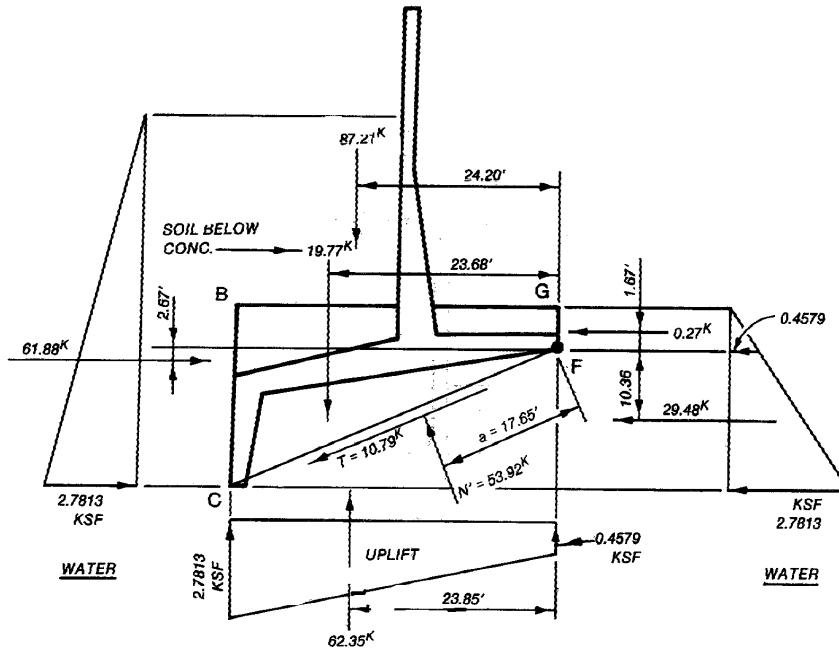

$$\begin{aligned}
 N' &= \Sigma V \cos \alpha + \Sigma H \sin \alpha \\
 T &= \Sigma H \cos \alpha - \Sigma V \sin \alpha \\
 N' &= 44.63 (0.9104) + 32.13 (0.4137) = 53.92 \text{ kips} \\
 T &= 32.13 (0.9104) - 44.63 (0.4137) = 10.79 \text{ kips} \\
 L_{CF} &= 42.29 \text{ ft}
 \end{aligned}$$

For sliding stability to be satisfied

$$T \leq \frac{N' \tan \phi + cL}{FS} \quad [4-12]$$

$$L = L_{CF}$$

$$N' \tan \phi + cL_{CF} = 53.92 (0.364) + 0.4 (42.29) = 36.54 \text{ kips}$$

From Table 4-2, the minimum FS required is 1.5.

$$T \leq \frac{36.54}{1.5}$$

$$10.79 \leq 24.36$$

Criterion is satisfied.

f. Bearing capacity (Chapter 5).

$$\alpha = 24.44^\circ, \quad \delta = \tan^{-1} \left(\frac{T}{N'} \right) = \tan^{-1} \left(\frac{10.79}{53.92} \right) = 11.32^\circ \text{ (Figure 5-1)}$$

$$\alpha = 0.427 \text{ rad}$$

$$e = \frac{L_{CF}}{2} - a = \frac{42.29}{2} - 17.65 = 3.495$$

$$\bar{B} = L_{CF} - 2e = 42.29 - 2(3.495) = 35.30 \text{ ft}$$

$$D = 5 \text{ ft}, \quad \gamma_b = 0.0625, \quad q_o = \gamma_b D = 0.3125 \text{ ksf} \quad [5-8a]$$

$$\xi_{cd} = 1 + 0.2 \left(\frac{D}{\bar{B}} \right) \tan \left(45 + \frac{\phi}{2} \right) = 1 + 0.2 \left(\frac{5}{35.3} \right) (1.428) = 1.04 \quad [5-4a]$$

$$\xi_{qd} = \xi_{\gamma d} = 1 + 0.1 \left(\frac{D}{\bar{B}} \right) \tan \left(45 + \frac{\phi}{2} \right) = 1.02 \quad [5-4c]$$

$$\xi_{qt} = \xi_{\gamma t} = (1 - \alpha \tan \phi)^2 = (1 - 0.427 \times 0.364)^2 = 0.7133 \quad [5-6a]$$

$$\xi_{ct} = \xi_{qt} - \frac{1 - \xi_{qt}}{N_c \tan \phi} = 0.7133 - \frac{1 - 0.7133}{14.83 \times 0.364} = 0.66 \quad [5-6c]$$

$$\xi_{qi} = \xi_{ci} = \left(1 - \frac{\delta}{90}\right)^2 = \left(1 - \frac{11.32}{90}\right)^2 = 0.764 \quad [5-5a]$$

$$\xi_{\gamma i} = \left(1 - \frac{\delta}{\phi}\right)^2 = \left(1 - \frac{11.32}{20}\right)^2 = 0.188 \quad [5-5b]$$

$$N_c = 14.83, \quad N_q = 6.40, \quad N_\gamma = 2.87 \quad (\text{Table 5-1})$$

From Equation 5-2

$$Q = \bar{B} \left(\xi_{cd} \xi_{ci} \xi_{ct} c N_c + \xi_{qd} \xi_{qi} \xi_{qt} q_o N_q + \frac{\xi_{\gamma d} \xi_{\gamma i} \xi_{\gamma t} \bar{B} N_\gamma}{2} \right) \quad [5-2]$$

$$Q = 35.3 \left[1.04(0.764)(0.66)(0.4)(14.83) + 1.02(0.764)(0.7133)(0.3125)(6.4) + \frac{1.02(0.188)(0.7133)(35.3)(0.0625)(2.87)}{2} \right] = 164.34 \text{ kips}$$

$$FS = \frac{Q}{N'} = \frac{164.34}{53.92} = 3.05 > 3.00 \quad (\text{Table 4-2})$$

Bearing criterion is satisfied.

N-7. **EXAMPLE 7.** Analyze the wall for overturning, sliding and bearing capacity. Load Case C2b, breaking wave condition.

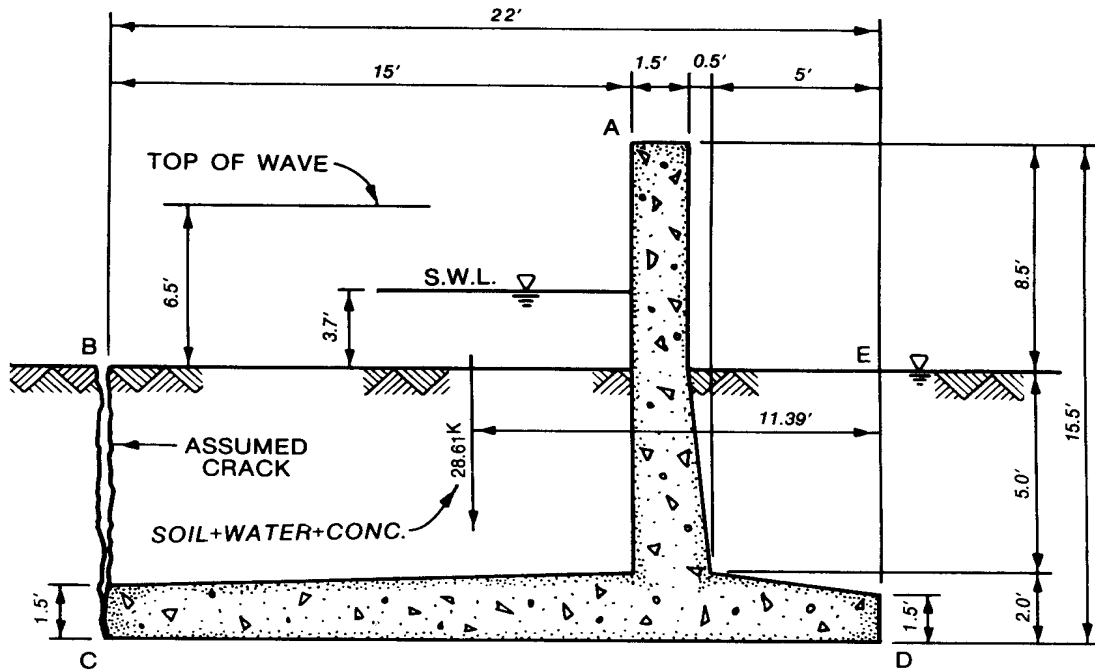

SOIL PROPERTIES: $\gamma_{SAT} = 0.125$ KCF
 $\phi = 0^\circ$
 $c = 0.90$ KSF

WATER: $\gamma_W = 0.064$ KCF

a. Water pressures (paragraphs 3-19 and 3-24d,f). Seepage from still water level (swl) (paragraph 3-24f):

$$L_{CD} = 22 \text{ ft}, \quad L_{DE} = 7.0 \text{ ft}, \quad L_S = 22 + 7 = 29 \text{ ft}$$

$$u_B = 3.7(0.064) = 0.237 \text{ ksf}$$

$$u_C = 10.7(0.064) = 0.685 \text{ ksf}$$

$$u_D = \left[10.7 - \frac{3.7(22)}{29} \right] 0.064 = 0.505 \text{ ksf} \quad (\text{on line of creep})$$

$$u_E = 0.0 \quad (\text{end creep, tail water})$$

Wave force (paragraph 3-24): Increase in static force, due to wave crest, above point C:

$$\frac{1}{2} (6.5 + 7.0)^2 (0.064) - \frac{1}{2} (3.7 + 7.0)^2 (0.064) = 5.832 - 3.664 = 2.168 \text{ kips}$$

$$5.832(13.5) \frac{1}{3} - 3.664(10.7) \frac{1}{3} = 13.176 \text{ ft-k}$$

$$2.168 \text{ k/LF acting at } \frac{13.176}{2.168} = 6.077 \text{ ft above point C.}$$

The dynamic force of the breaking wave is calculated from procedures found in Chapter 7 of the Shore Protection Manual.

Dynamic force of breaking wave = 5.176 kips at swl

b. Soil force (resisting side).

$$K_o = 1.00 \text{ (at-rest)}$$

$$\gamma' = \gamma_{\text{sat}} - \text{seepage uplift}$$

$$\gamma' = [7(0.125) - 0.505] \div 7 = 0.0529 \text{ kcf}$$

$$P_o = \frac{1}{2} K_o \gamma_b h^2 = \frac{1}{2} (1.00) (0.0529) (7)^2 = \underline{\underline{1.296 \text{ kips}}}$$

c. Overturning (paragraph 4-8). Initially, all of the base is assumed to be in compression. Full hydrostatic uplift is applied to any part of the base not in compression. The percent of the base in compression is recomputed until the assumed value equals the computed one. The final solution is shown below.

$$N' = \Sigma V = 15.25 \text{ kips}, \quad T = \Sigma H = 7.94 \text{ kips}$$

Using the minimum required FS of 1.25 given in Table 4-3 yields

$$7.40 \leq \frac{15.25 \tan 0^\circ + 0.9(18.96)}{1.25}$$

$$7.40 \leq 13.65$$

Sliding criterion is satisfied.

e. Bearing capacity (Chapter 5).

$$\delta = \tan^{-1} \left(\frac{\Sigma H}{\Sigma V} \right) = \tan^{-1} \left(\frac{7.94}{15.25} \right) = 27.50^\circ \text{ (Figure 5-1)}$$

$$e = \frac{B}{2} - x_R = \frac{22}{2} - 6.32 = 4.68 \text{ ft}$$

$$\bar{B} = B - 2e = 22 - 2(4.68) = 12.64 \text{ ft}$$

$$N_c = 5.14, \quad N_q = 1.00 \text{ (Table 5-1)}$$

$$D = 7 \text{ ft}, \quad \gamma_b = \gamma' = 0.125 - 0.064 = 0.061 \text{ kcf}$$

$$q_o = \gamma' D = 0.061(7) = 0.427 \text{ ksf} \quad [5-8a]$$

$$\xi_{cd} = 1 + 0.2 \left(\frac{D}{\bar{B}} \right) = 1 + 0.2 \left(\frac{7}{12.64} \right) = 1.111 \quad [5-4a]$$

$$\xi_{qd} = 1.00 \quad [5-4b]$$

$$\xi_{ci} = \xi_{qi} = \left(1 - \frac{\delta}{90} \right)^2 = \left(1 - \frac{27.50}{90} \right)^2 = 0.482 \quad [5-5a]$$

From Equation 5-2

$$Q = \bar{B} \left(\xi_{cd} \xi_{ci} c N_c + \xi_{qd} \xi_{qi} q_o N_q \right)$$

$$Q = 12.64 \left[1.111(0.482)(0.9)(5.14) + 1.00(0.482)(0.427)(1.00) \right]$$

$$Q = 33.91 \text{ kips}$$

Using Equation 5-1 yields

$$FS = \frac{Q}{N'} = \frac{33.91}{15.25} = 2.22 > 1.50 \quad (\text{Table 4-3})$$

Bearing criterion is satisfied.

APPENDIX O

COMPUTER PROGRAM ABSTRACTS FOR REFERENCED PROGRAMS

O-1. Computer program abstracts included in Appendix O are: Bearing Capacity Analysis of Shallow Foundations (CBEAR); CFRAG - Seepage Analysis of Confined Flow Problems by the Method of Fragments; CSLIDE - Sliding Stability Analysis of Concrete Structures; Seepage Package; UTEXAS2-University of Texas Analysis of Slopes-Version 2; An Interactive Graphics Three-Dimensional Geometry Program; CSTR - Concrete Strength Investigation and Design of Hydraulic Structures; User's Guide for Concrete Strength Investigation and Design (CASTR) in Accordance with ACI 318-83.

CATEGORY A

CBEAR		ELECTRONIC COMPUTER PROGRAM ABSTRACT	
TITLE OF PROGRAM Bearing Capacity Analysis of Shallow Foundations (CBEAR) (I0017)		PROGRAM NO. 741-F3-R0107	
PREPARING AGENCY US Army Engineer Waterways Experiment Station, Automatic Data Processing Center, PO Box 631, Vicksburg, MS 39180			
AUTHOR(S) Reed L. Mosher and Michael E. Pace		DATE PROGRAM COMPLETED June 1982	STATUS OF PROGRAM PHASE FINAL STAGE OPER
A. PURPOSE OF PROGRAM This program can be used for the analysis of the bearing capacity of shallow strip, rectangular, square, or circular foundations on one- or two-layer soil systems. The bearing capacity can be computed considering the effects of embedment of the foundation, inclination of the foundation base, inclined loads, a sloping soil surface, eccentric loads in three dimensions, submerged soil, or surcharge.			
B. PROGRAM SPECIFICATIONS Timesharing FORTRAN Program.			
C. METHODS The bearing capacity of an infinite strip footing is derived based on the classical theory of plasticity using limit equilibrium analysis. The soil behavior is assumed to be as follows: (a) Mohr-Coulomb failure criteria govern; (b) shear strength at any point is independent of strain; (c) elastic deformations are negligible with respect to plastic deformation; and (d) volume change due to stress is negligible.			
D. EQUIPMENT DETAILS			
E. INPUT-OUTPUT Data is input from a prepared data file in free field format or from the user's terminal during execution. If the data are input from a terminal the user may enter data by using key command words or by following a prompting sequence. Output from the program may be directed to a file or printed at the user's terminal.			
F. ADDITIONAL REMARKS Program is available through the <u>CORPS</u> on WES DPS/1, CSC H6000 at Macon, GA. A copy of the program and documentation may be obtained from the Engineering Computer Programs Library (ECPL), WES, telephone number: commercial (601) 634-2581 or FTS 542-2581.			

WES FORM 2205
1 JUL 80

REPLACES ENG FORM 2883 WHICH IS OBSOLETE.

CATEGORY A

CFRAG ELECTRONIC COMPUTER PROGRAM ABSTRACT		
TITLE OF PROGRAM CFRAG - Seepage Analysis of Confined Flow Problems by the Method of Fragments (I0018)		PROGRAM NO. 741-F3-R0108
PREPARING AGENCY US Army Engineer Waterways Experiment Station, Automatic Data Processing Center, PO Box 631, Vicksburg, MS 39180		
AUTHOR(S) Michael E. Pace, Dennis R. Williams, Thomas F. Wolff, and Reed Mosher	DATE PROGRAM COMPLETED October 1983	STATUS OF PROGRAM PHASE STAGE OP
A. PURPOSE OF PROGRAM CFRAG is a seepage program designed to analyze groundwater flow using the method of fragments. The program can be used to compute: (1) seepage through soil mediums which can be model using fragments; (2) head losses; (3) exit gradients; and (4) resultant uplift and lateral forces.		
B. PROGRAM SPECIFICATIONS The CFRAG program is written in FORTRAN 66. The Corps time-sharing library file name is I0018.		
C. METHODS The method of fragments is an approximate analytical procedure for computing groundwater flow. The principle assumptions used in the derivation of this method are: (1) the flow is confined and of finite depth; (2) Darcy's law is valid, therefore, laminar flow exists; (3) steady state flow exists; (4) the soil medium is homogeneous and isotropic; and (5) equipotential lines at certain locations of the flow region can be approximated by vertical lines.		
D. EQUIPMENT DETAILS Time-sharing computer (Honeywell level 66, CDC Cyber, or Harris 500).		
E. INPUT-OUTPUT Input - Data may be supplied from a prepared data file or from the user's terminal during execution. If the data are input from the terminal, the user may enter data by using key command words or by following a prompting sequence. Output - Provides an echoprint of the input data and results of the analysis.		
F. ADDITIONAL REMARKS A copy of the program and documentation may be obtained from the Engineering Computer Programs Library, WES; telephone: (601) 634-2581 or FTS 542-2581.		

CSLIDE ELECTRONIC COMPUTER PROGRAM ABSTRACT			
TITLE OF PROGRAM CSLIDE - Sliding Stability Analysis of Concrete Structures (X0075)		PROGRAM NO. 713-F3-R0075	
PREPARING AGENCY US Army Engineer Waterways Experiment Station, Information Technology Laboratory, PO Box 631, Vicksburg, MS 39180			
AUTHOR(S) Michael E. Pace and Virginia R. Noddin		DATE PROGRAM COMPLETED July 1986	STATUS OF PROGRAM
		PHASE	STAGE OP
A. PURPOSE OF PROGRAM			
<p>This program was developed to assess the sliding stability of concrete structures using the limit equilibrium method described in the Engineering Technical Letter (ETL) 1110-2-256.</p>			
B. PROGRAM SPECIFICATIONS			
<p>CSLIDE is written in FORTRAN 77.</p>			
C. METHODS			
<p>The program utilizes the limit equilibrium wedge method described in ETL 1110-2-256. The program performs an iterative search to find the failure surface with the minimum factor of safety.</p> <p style="text-align: right;">(Continued)</p>			
D. EQUIPMENT DETAILS			
<p>The program is operational on the Honeywell DPS-8 CDC Cyber, and Harris 500 computers in the time-sharing mode. Any ASCII time-sharing terminal may be used, but if graphics are desired a Tektronix 4014 terminal must be used.</p>			
E. INPUT-OUTPUT			
<p>Input - Data may be supplied from a prepared data file or from the user's terminal during execution. If the data are input from the terminal, the user may enter data by using key command words or by following a prompting sequence. All data are read in free-field format.</p> <p>Output - An echoprint of the input data and the results of the analysis in tabular and graphical form may be obtained.</p>			
F. ADDITIONAL REMARKS			
<p>A copy of the program and documentation may be obtained from the Engineering Computer Programs Library (ECPL), WES; telephone: (601) 634-2581 or FTS 542-2581.</p> <p>This program is designated X0075 in the <u>CORPS</u> Library.</p>			

C. METHODS (Continued)

CSLIDE can compute the factor of safety against sliding considering the effects of:

- a. Multiple soil layers with irregular surfaces.
- b. Water and seepage effects.
- c. Applied vertical surcharge loads which include line, strip, triangular, uniform, and ramp loads.
- d. Applied horizontal point loads.
- e. Irregular shaped structural geometry with either a horizontal or sloped base.
- f. A percentage of the base of the structure in compression due to over-turning effects.
- g. Single or multiple failure planes.
- h. Horizontal and vertical induced loads due to earthquake accelerations.
- i. Factors which require the user to predetermine the failure surface.

CATEGORY B

FEMSEEP		ELECTRONIC COMPUTER PROGRAM ABSTRACT	
TITLE OF PROGRAM Seepage Package (X8202)		PROGRAM NO. 704-F3-R0009	
PREPARING AGENCY US Army Engineer Waterways Experiment Station, Information Technology Laboratory, PO Box 631, Vicksburg, MS 39180			
AUTHOR(S)	DATE PROGRAM COMPLETED	STATUS OF PROGRAM	
Fred T. Tracy	January 1983	PHASE	STAGE OP
A. PURPOSE OF PROGRAM			
To (1) interactively generate a finite element (FE) grid, (2) to perform a FEM seepage analysis, and (3) to plot the results.			
B. PROGRAM SPECIFICATIONS			
The driver runs in timesharing and calls X8200 (704-F3-R0006) for grid generation, 704-F3-R0011 for seepage analysis, and X8201 (704-F3-R0005) for post-processing.			
C. METHODS			
Four-sided isoparametric elements are used primarily in grid generation, the finite element method is used for the seepage analysis, and flow nets, contouring, vector, and number plots are used in the post processing.			
D. EQUIPMENT DETAILS			
Output is displayed on a storage tube terminal such as the Tektronix 4012 or 4014. The program is operational on Honeywell, CDC, and Harris computers.			
E. INPUT-OUTPUT			
Input/output is performed using a graphics terminal in the time-sharing environment.			
F. ADDITIONAL REMARKS			
The seepage analysis consists of steady-state solutions to plane or axisymmetric, confined or unconfined, and homogeneous or inhomogenous problems. Documentation may be obtained from the Engineering Computer Programs Library (ECPL), WES, telephone number: commercial (601) 634-2581 or FTS 542-2581.			

WES FORM 2205
1 JUL 80

REPLACES ENG FORM 2883 WHICH IS OBSOLETE.

ELECTRONIC COMPUTER PROGRAM ABSTRACT			
TITLE OF PROGRAM UTEXAS2-University of Texas Analysis of <u>Slopes-Version 2 (I0029)</u>		PROGRAM NO.	
PREPARING AGENCY US Army Engineer Waterways Experiment Station, Information Technology Lab and Geotechnical Lab, PO Box 631, Vicksburg, MS 39180-0631.			
AUTHOR(S) (See reverse)	DATE PROGRAM COMPLETED	STATUS OF PROGRAM	
		PHASE	STAGE OP
A. PURPOSE OF PROGRAM			
<p>UTEXAS2 is a slope stability program designed to analyze slopes by any of four methods. The program will calculate the safety factor for either a prescribed shear surface or for a search of the critical shear surface. Both circular and non-circular shear surfaces can be evaluated.</p>			
B. PROGRAM SPECIFICATIONS			
<p>The UTEXAS2 program is written in FORTRAN 77. The CORPS time-sharing library file name is I0029.</p>			
C. METHODS			
<p>The four analysis procedures are: Spencer's method, Simplified Bishop's procedure, Modified Swedish procedure with the Corps' side force assumption, and Modified Swedish procedure with Lowe and Karafiath's side force assumption. There are five options for type of shear strength data utilized and six options for specifying pore pressures. All analysis procedures and major features can be run in a single data file.</p>			
D. EQUIPMENT DETAILS			
<p>Microcomputer with a least 512K memory, a hard disk, and a math co-processor. Time-sharing computer (CDC Cyber, or Harris 500) with Tektronix 4014 terminal or emulator for graphics.</p>			
E. INPUT-OUTPUT			
<p>Input - Data is supplied from a prepared data file which allows for free-field input and requires command words.</p> <p>Output - Provides an echoprint of the input data and results of the analysis in an output file divided into a series of tables.</p>			
F. ADDITIONAL REMARKS			
<p>Graphics capability for displaying the input data and the final shear surface is available. A copy of the program and documentation may be obtained from the Engineering Computer Programs Library, WES, telephone: (601) 634-2581 or FTS 542-2581.</p>			

EM 1110-2-2502
29 Sep 89

AUTHOR(S) (Continued).

Dr. Stephen G. Wright-Univ. of Texas, Austin; POC-Earl Edris, Geotech Lab and
Reed Mosher, Information Tech Lab

CATEGORY B

3DSAD ELECTRONIC COMPUTER PROGRAM ABSTRACT			
TITLE OF PROGRAM An Interactive Graphics Three-Dimensional Geometry Program (X8100)		PROGRAM NO. 713-F3-R0008	
PREPARING AGENCY US Army Engineer Waterways Experiment Station, Automatic Data Processing Center, PO Box 631, Vicksburg, MS 39180			
AUTHOR(S) Fred T. Tracy	DATE PROGRAM COMPLETED October 1978	STATUS OF PROGRAM	
		PHASE OP	STAGE
A. PURPOSE OF PROGRAM Program allows user to describe the geometry of a three dimensional structure, interactively plot the described structure, and compute weight and centroid information for individual pieces or the sum total for the structure. Other modules of the program apply generalized loading forces and pressures and perform overturning and sliding analyses.			
B. PROGRAM SPECIFICATIONS FORTRAN, Time-sharing program.			
C. METHODS Use a right handed coordinate system. Solid pieces of the structures may be described as (1) block - a two-dimensional cross-section extended in the third direction, (2) an eight node brick element, (3) a cluster of surfaces to form a solid.			
D. EQUIPMENT DETAILS Low speed graphics terminal, Central processor.			
E. INPUT-OUTPUT Input must be by a basic data file with addition and display commands entered. Output will be displayed directly on the terminal.			
F. ADDITIONAL REMARKS Program is available through the <u>CORPS</u> on WES G-635, CSC H600 at Macon, GA, and Boeing Computer Services. Reports include: 1. General Geometry Module 2. General Loads Module 3. General Analyses Module			

CATEGORY B

ELECTRONIC COMPUTER PROGRAM ABSTRACT			
TITLE OF PROGRAM CSTR - Concrete Strength Investigation and Design of Hydraulic Structures (X0066)		PROGRAM NO. 713-F3-R0066	
PREPARING AGENCY US Army Engineer Waterways Experiment Station, Automation Technology Center, PO Box 631, Vicksburg, MS 39180-0631			
AUTHOR(S) C. C. Hamby (LMKED-DS) and W. A. Price III (WESKA-E)		DATE PROGRAM COMPLETED September 1984	STATUS OF PROGRAM PHASE Operational
STAGE			
A. PURPOSE OF PROGRAM To perform investigation or design of concrete beams or columns in accordance with ETL 1110-2-265 for hydraulic structures.			
B. PROGRAM SPECIFICATIONS Written in FORTRAN IV using the Graphics Compatibility System (GCS). The CORPS time-sharing library file name is X0066.			
C. METHODS Strength analysis for investigation or design of rectangular cross sections of hydraulic structures subjected to axial load plus uniaxial flexure. Analysis is based on the rectangular stress block described in ETL 1110-2-265.			
D. EQUIPMENT DETAILS Tektronix 4014 terminal, if graphics output is desired, otherwise, any ASCII time-sharing terminal.			
E. INPUT-OUTPUT Input is from a data file; output is to a Tektronix 4014 graphics terminal or regular printing terminal.			
F. ADDITIONAL REMARKS A copy of the program and documentation may be obtained from the Engineering Computer Programs Library, WES; telephone: (601) 634-2581 or FTS 542-2581. The User's Guide for this program is WES IR K-84-9.			

ELECTRONIC COMPUTER PROGRAM ABSTRACT			
TITLE OF PROGRAM		PROGRAM NO.	
User's Guide for Concrete Strength Investigation and Design (CASTR) in Accordance with ACI 318-83		713-F3-R0067	
PREPARING AGENCY US Army Engineer Waterways Experiment Station, Information Technology Laboratory, PO Box 631, Vicksburg, MS 39180-0631			
AUTHOR(S)		DATE PROGRAM COMPLETED	STATUS OF PROGRAM
C. C. Hamby (LMKED-DS) and W. A. Price III (WESKA-E)		October 1985	PHASE Operational
STAGE			
A. PURPOSE OF PROGRAM			
To perform investigation or design of concrete beams or columns in accordance with ACI Code 318 for nonhydraulic structures.			
B. PROGRAM SPECIFICATIONS			
Written in FORTRAN IV using the Graphics Compatibility System (GCS). The CORPS time-sharing library file name is X0067.			
C. METHODS			
Strength analysis for investigation or design of rectangular cross sections of nonhydraulic structures subjected to axial load plus uniaxial flexure. Analysis is based on the rectangular stress block approximation described in Section 10.2.7 of ACI 318-83.			
D. EQUIPMENT DETAILS			
Tektronix 4014 terminal, if graphics output is desired, otherwise, any ASCII time-sharing terminal.			
E. INPUT-OUTPUT			
Input is from a data file; output is to a Tektronix 4014 graphics terminal or regular printing terminal.			
F. ADDITIONAL REMARKS			
Input data are prepared the same as for program 713-F3-R0 066, "CSTR-Concrete Strength Investigation and Design of Hydraulic Structures (X0066)." Differences between the two programs lie only in the stress block depth and other parameters. Call WES, (601) 634-2300 or FTS 542-2300 for more information.			

GLOSSARY

TERMS

Active earth pressure: Minimum horizontal pressure condition which develops when a wall rotates about its base and away from the backfill 0.001 to 0.003 radian (see paragraphs 3-4a and 3-5, and Figure 3-1).

At-rest earth pressure: Lateral pressure condition when no wall movement occurs (see paragraphs 3-4c, 3-7, 3-10, and Figure 3-1).

Bond breaker: A coating or sheet of a substance that does not adhere to concrete, placed on one monolith in the area where concrete will be placed later, to maintain separate movement of the two monoliths.

Breaking wave: See "waves."

Broken wave: See "waves."

Buttress: A vertical fin, turned perpendicular to the stem, placed monolithic with the stem and heel so as to brace the stem into a series of wall slabs supported at the base and the buttresses.

c: Symbol for cohesion value (see paragraph 3-5 and Figure 3-8).

Coastal flood wall: A flood wall that is resisting the effects of the surge tide and waves accompanying a storm. See paragraphs 4-1a and 7-1.

Closed-face structure (Chapter 10): A prefabricated facing system for an alternative type of retaining wall, where the facing has no openings. The joints between precast panels will form a pattern but vegetation cannot grow through them. See open-face structure.

Counterfort: Like a buttress, except located over the toe instead of over the heel. The fin is in tension instead of the compression of the buttress.

Diffraction (of waves): The effect of bending of the direction of propagation (travel) of a wave crest as it passes by the end of a jetty or through an opening. Thus the wave pattern spreads outward into the sheltered region within the barrier's geometric shadow.

Drained phi value: Phi value of a soil, as determined by an S test.

Drained soil tests: Tests in which the confining and shear stresses are applied so slowly that pore water pressure does not build up. An increase in applied stress produces an equal increase in effective stress.

Driving force: A force acting to move the wall, usually caused by earth and water beyond the end of the heel. See paragraph 3-7.

Driving wedge: A wedge of soil which produces a horizontal force (a driving force) tending to cause instability of a wall. See paragraph 3-7.

Fetch: The area of water in which waves are generated by a wind having a fairly constant direction and speed. Sometimes used synonymously with "fetch length," the horizontal distance over which a wind generates waves.

Frequency of a wave: See "waves."

Heel: The heel of a wall is the base slab projection pointing toward the net driving force.

Kern: The portion of the area under the base such that when the resultant normal force ("N'" or "V" in the figures in this manual) is inside the kern, the entire base is in compression contact with the subgrade. When the resultant normal force is located outside the kern, some portion of the base will be tending to lift off of the subgrade instead of being in compression contact. For a rectangular base, the edges of the kern will lie at the one-third points of the base width, as shown in Figure 4-4.

Nonbreaking wave: See "waves."

Open-faced structure (Chapter 10): A prefabricated facing system for an alternative type of retaining wall, where the precast facing units have openings between or through them. Vegetation, usually evergreen, is then planted so as to grow through the openings and present a more natural appearance of the wall's exposed face.

Phi: Angle of internal friction of earth (see Figure 3-1).

Passive earth pressure: Pressure condition that develops when a wall is moved toward backfill, causing horizontal stresses to increase and shear stresses to reverse direction (see paragraphs 3-4b and 3-5).

Protected side (of a flood wall or seawall): The side facing the area protected from flooding.

Q test (of soil): Also known as an unconsolidated undrained or UU test. Both the confining and shearing stresses are applied so rapidly that the neutral stress supports all the added load, and there is no change in water content.

R test (of soil): Also known as a consolidated undrained or CU test. The confining stresses are applied to the soil so slowly that the neutral stress is not changed and the soil consolidates fully. The shear stress, however, is applied so quickly that the neutral stress carries all this change, and there is no further consolidation or change in water content.

Refraction (of a wave): The process by which the direction of movement is changed for a wave moving in shallow water at an angle to the underwater contours: the part of the wave advancing in shallower water moves more slowly

than that part still advancing in deeper water, causing the wave crest to bend toward alignment with the underwater contours.

Resisting force: A force tending to resist movement of a wall. See paragraph 3-8.

Resisting wedge: A wedge of soil which produces a lateral reaction (a resisting force) which tends to resist instability of a wall. See paragraph 3-8.

S test (of soil): Also known as a consolidated drained or CD test. The confining stresses are applied so slowly that the neutral stress does not change. The soil consolidates with no change in neutral stress.

Seawall: See paragraph 1-4a, especially the comparison with a coastal flood wall. A seawall is usually a gravity structure for the purpose of protecting the area behind it from the action of tide and waves in front of it, sometimes with a face shaped to dissipate wave energy.

Shoaling: Point at which the water depth gets more shallow as the wave crest approaches the shoreline or a wall.

Stem: The vertical wall portion of a cantilever inverted-T wall.

Surge stillwater level: A rise above normal water level on the open coast due to the action of wind stress on the water surface. Surges resulting from hurricanes also include the rise in level due to atmospheric pressure reduction.

Structural wedge: The structural wedge consists of the structure itself with any soil and water contained within the boundaries of the structure or over the base.

Toe: The toe of a wall is the portion of the base slab pointing toward the net resisting force.

Train, wave: See "waves."

Undrained soil tests: Tests where the pore water pressure is not allowed to dissipate and the water carries all of the applied stresses.

Unprotected side of a flood wall or seawall: The side of the wall facing the storm tide and waves, or rising water.

Wall friction: The angle of friction between a soil mass tending to move parallel along the interface between the soil mass and a wall. See paragraph 3-14.

Water stop: A strip of material, cast into each of two adjacent concrete monoliths and spanning the space between them, for the purpose of preventing the flow of water through the space. Usually made of elastomeric material for

civil works structures, but also made of sheet metal. See paragraph 7-13 and Figure 7-9.

Wave parameter definitions (see paragraph 3-24) are best obtained from Chapter 7 of the Shore Protection Manual (U. S. Army Engineer Waterways Experiment Station 1984).^{*} Abbreviated definitions are shown below.

Breaking wave: While there are several types of breaking waves, the type associated with the high-impulse effects used in this manual is the plunging breaker, where the wave crest becomes more and more steep, until the crest curls forward and falls over a pocket of trapped air. This is characterized by a very large dynamic impulse of short (0.2 second, approximately) duration and a rise in hydrostatic pressure from still water (no wave) up to the crest one-half of the wave height above still water. See paragraph 3-24d.

Broken wave: A somewhat confused mass of water surging forward after the wave has broken some distance away from the wall. See paragraph 3-24e.

Nonbreaking wave: A wave impacting on a wall under conditions where there is no breaking tendency but the mass of water is stopped from forward motion by the wall and imparts its energy to the vertical face. See paragraph 3-24c.

Wave height: The vertical distance from the crest of a wave to the adjacent trough (lowest elevation). A continuously changing value in a typical train of waves, frequently assumed to have a Gaussian distribution. See paragraph 3-24b for the assumed values as fractions of the significant wave height (an average of the highest one-third of all of the waves in the wave train is assumed for design of the structure).

Wave length: The horizontal distance from one wave crest to the next crest in the group (train) of waves. A continuously changing value in a typical train of waves, frequently assumed to have a Gaussian distribution.

Wave steepness: The ratio of wave height to wave length.

Wave train: A group of waves coming from the same direction over the same fetch.

Wave frequency: The number of wave crests passing a given point in one second, the reciprocal of the wave period.

Wave period: The time in seconds required for a wave crest to travel a distance of one wave length, the reciprocal of the frequency.

^{*} References cited in this appendix may be found in Appendix A, "References."