



PDHonline Course C135 (6 PDH)

Pavement Design

Instructor: John C. Huang, Ph.D., PE

2020

PDH Online | PDH Center

5272 Meadow Estates Drive
Fairfax, VA 22030-6658
Phone: 703-988-0088
www.PDHonline.com

An Approved Continuing Education Provider

UNIFIED FACILITIES CRITERIA (UFC)

PAVEMENT DESIGN FOR ROADS, STREETS, WALKS, AND OPEN STORAGE AREAS



APPROVED FOR PUBLIC RELEASE; DISTRIBUTION UNLIMITED

UNIFIED FACILITIES CRITERIA (UFC)

**PAVEMENT DESIGN FOR ROADS, STREETS, WALKS, AND OPEN STORAGE
AREAS**

Any copyrighted material included in this UFC is identified at its point of use.
Use of the copyrighted material apart from this UFC must have the permission of the
copyright holder.

U.S. ARMY CORPS OF ENGINEERS (Preparing Activity)

NAVAL FACILITIES ENGINEERING COMMAND

AIR FORCE CIVIL ENGINEER SUPPORT AGENCY

Record of Changes (changes are indicated by \1\ ... /1/)

| Change No. | Date | Location |
|-------------------|-------------|-----------------|
| | | |
| | | |

This UFC supersedes TM 5-822-5, dated 12 June 1992. The format of this UFC does not conform to UFC 1-300-01; however, the format will be adjusted to conform at the next revision. The body of this UFC is the previous TM 5-822-5, dated 12 June 1992.

FOREWORD

v\

The Unified Facilities Criteria (UFC) system is prescribed by MIL-STD 3007 and provides planning, design, construction, sustainment, restoration, and modernization criteria, and applies to the Military Departments, the Defense Agencies, and the DoD Field Activities in accordance with [USD\(AT&L\) Memorandum](#) dated 29 May 2002. UFC will be used for all DoD projects and work for other customers where appropriate. All construction outside of the United States is also governed by Status of forces Agreements (SOFA), Host Nation Funded Construction Agreements (HNFA), and in some instances, Bilateral Infrastructure Agreements (BIA.) Therefore, the acquisition team must ensure compliance with the more stringent of the UFC, the SOFA, the HNFA, and the BIA, as applicable.

UFC are living documents and will be periodically reviewed, updated, and made available to users as part of the Services' responsibility for providing technical criteria for military construction. Headquarters, U.S. Army Corps of Engineers (HQUSACE), Naval Facilities Engineering Command (NAVFAC), and Air Force Civil Engineer Support Agency (AFCEA) are responsible for administration of the UFC system. Defense agencies should contact the preparing service for document interpretation and improvements. Technical content of UFC is the responsibility of the cognizant DoD working group. Recommended changes with supporting rationale should be sent to the respective service proponent office by the following electronic form: [Criteria Change Request \(CCR\)](#). The form is also accessible from the Internet sites listed below.

UFC are effective upon issuance and are distributed only in electronic media from the following source:

- Whole Building Design Guide web site <http://dod.wbdg.org/>.

Hard copies of UFC printed from electronic media should be checked against the current electronic version prior to use to ensure that they are current.

AUTHORIZED BY:



DONALD L. BASHAM, P.E.
Chief, Engineering and Construction
U.S. Army Corps of Engineers



DR. JAMES W. WRIGHT, P.E.
Chief Engineer
Naval Facilities Engineering Command



KATHLEEN I. FERGUSON, P.E.
The Deputy Civil Engineer
DCS/Installations & Logistics
Department of the Air Force



Dr. GET W. MOY, P.E.
Director, Installations Requirements and
Management
Office of the Deputy Under Secretary of Defense
(Installations and Environment)

**ARMY
AIR FORCE**

**TM 5-822-5
AFM 88-7, CHAP. 1**

**PAVEMENT DESIGN FOR ROADS,
STREETS, WALKS, AND
OPEN STORAGE AREAS**

APPROVED FOR PUBLIC RELEASE; DISTRIBUTION IS UNLIMITED

DEPARTMENTS OF THE ARMY AND THE AIR FORCE

JUNE 1992

REPRODUCTION AUTHORIZATION/RESTRICTIONS

This manual has been prepared by or for the Government and is public property and not subject to copyright.

Reprints or republications of this manual should include a credit substantially as follows: “Joint Departments of the Army and Air Force, TM 5-822-5/AFM 88-7, Chapter 1, Pavement Design for Roads, Streets, Walks, and Open Storage Areas, 12 June 1992.”

PAVEMENT DESIGN FOR ROADS, STREET, WALKS, AND OPEN STORAGE AREAS

| | <i>Paragraph</i> | <i>Page</i> |
|--|------------------|-------------|
| CHAPTER 1. INTRODUCTION | | |
| Purpose | 1-1 | 1-1 |
| Scope | 1-2 | 1-1 |
| References | 1-3 | 1-1 |
| Selection of Pavement Type | 1-4 | 1-1 |
| Basis of Design | 1-5 | 1-1 |
| Computer Aided Design | 1-6 | 1-1 |
| CHAPTER 2. PRELIMINARY INVESTIGATIONS | | |
| General | 2-1 | 2-1 |
| Investigations of Site | 2-2 | 2-1 |
| Soil Conditions | 2-3 | 2-1 |
| Borrow Areas | 2-4 | 2-1 |
| CHAPTER 3. VEHICULAR TRAFFIC | | |
| Effect on Pavement Design | 3-1 | 3-1 |
| Traffic Evaluation | 3-2 | 3-1 |
| CHAPTER 4. FLEXIBLE PAVEMENT SUBGRADES | | |
| Factors To Be Considered | 4-1 | 4-1 |
| Compaction | 4-2 | 4-1 |
| Compaction Example | 4-3 | 4-1 |
| Selection of Design CBR Values | 4-4 | 4-2 |
| CHAPTER 5. FLEXIBLE PAVEMENT SELECT MATERIALS AND SUBBASE COURSES | | |
| General | 5-1 | 5-1 |
| Materials | 5-2 | 5-1 |
| Compaction | 5-3 | 5-4 |
| Drainage | 5-4 | 5-2 |
| Selection of Design CBR Values | 5-5 | 5-2 |
| CHAPTER 6. FLEXIBLE PAVEMENT BASE COURSES | | |
| Materials | 6-1 | 6-1 |
| Compaction | 6-2 | 6-1 |
| Drainage | 6-3 | 6-1 |
| Selection of Design CBR | 6-4 | 6-1 |
| Minimum Thickness | 6-5 | 6-1 |
| CHAPTER 7. BITUMINOUS PAVEMENT | | |
| General | 7-1 | 7-1 |
| Criteria for Bituminous Pavements | 7-2 | 7-1 |
| CHAPTER 8. FLEXIBLE PAVEMENT DESIGN | | |
| General | 8-1 | 8-1 |
| Design Procedure | 8-2 | 8-1 |
| Design Index | 8-3 | 8-1 |
| Thickness Criteria-Conventional Flexible Pavements | 8-4 | 8-1 |
| Example Thickness Design-Conventional Flexible Pavements | 8-5 | 8-2 |
| Thickness Criteria-Stabilized Soil Layers | 8-6 | 8-3 |
| Example Thickness Design-Stabilized Soil Layers | 8-7 | 8-4 |
| Shoulders and Similar Areas | 8-8 | 8-4 |
| Bituminous Sidewalks | 8-9 | 8-5 |
| Bituminous Driveways | 8-10 | 8-5 |

This publication with special software (Appendix E) has a value of less than \$100.00 per copy, and does not require accountability under the provisions of AR 735-17 and AR 710-2-1.

APPROVED FOR PUBLIC RELEASE; DISTRIBUTION IS UNLIMITED

*This manual supersedes TM 5-822-5/AFM 88-7, Chap 3, dated 1 October 1980 and TM 5-822-6/AFM 88-7, Chap 1, dated 1 April 1977.

| | <i>Paragraph</i> | <i>Page</i> |
|---|------------------|-------------|
| Curbs and Gutters | 8-11 | 8-6 |
| Flexible Overlay Design | 8-12 | 8-6 |
| CHAPTER 9. RIGID PAVEMENT SUBGRADES | | |
| Soil Classification and Tests | 9-1 | 9-1 |
| Compaction | 9-2 | 9-1 |
| Treatment of Unsuitable Soils | 9-3 | 9-1 |
| Determination of Modulus of Subgrade Reaction | 9-4 | 9-2 |
| CHAPTER 10. RIGID PAVEMENT BASE COURSES | | |
| General Requirements | 10-1 | 10-1 |
| Materials | 10-2 | 10-1 |
| Compaction | 10-3 | 10-1 |
| Frost Requirements | 10-4 | 104 |
| CHAPTER 11. CONCRETE PAVEMENT | | |
| Mix Proportioning and Control | 11-1 | 11-1 |
| Testing | 11-2 | 11-1 |
| Special Conditions | 11-3 | 11-1 |
| CHAPTER 12. PLAIN CONCRETE PAVEMENT DESIGN | | |
| General | 12-1 | 12-1 |
| Roller-Compacted Concrete Pavements | 12-2 | 12-1 |
| Design Procedure | 12-3 | 12-1 |
| Design Procedure for Stabilized Foundations | 12-4 | 12-3 |
| Design Examples | 12-5 | 12-4 |
| Concrete Sidewalks | 12-6 | 12-4 |
| Concrete Driveways | 12-7 | 12-5 |
| Curbs, Gutters, and Shoulders | 12-8 | 12-5 |
| CHAPTER 13. REINFORCED CONCRETE PAVEMENTS | | |
| Application | 13-1 | 13-1 |
| Design Procedure | 13-2 | 13-3 |
| Limitations | 13-3 | 13-5 |
| Reinforcing Steel | 13-4 | 13-5 |
| Design Examples | 13-5 | 13-5 |
| Design Details | 13-6 | 13-6 |
| CHAPTER 14. PAVEMENT OVERLAYS | | |
| General | 14-1 | 14-1 |
| Definitions and Symbols for Overlay Pavement Design | 14-2 | 14-1 |
| Preparation of Existing Pavement | 14-3 | 14-1 |
| Condition of Existing Rigid Pavement | 14-4 | 14-2 |
| Rigid Overlay of Existing Rigid Pavement | 14-5 | 14-2 |
| Rigid Overlay of Existing Flexible or Composite Pavements | 14-6 | 14-4 |
| Flexible Overlay of Flexible Pavements | 14-7 | 14-4 |
| Flexible Overlay of Rigid Base Pavement | 14-8 | 14-4 |
| Use of Geotextiles to Retard Reflective Cracking | 14-9 | 14-7 |
| Overlays in Frost Regions | 14-10 | 14-8 |
| Overlay Design Example | 14-11 | 14-8 |
| CHAPTER 15. JOINTS FOR PLAIN CONCRETE | | |
| Design Details | 15-1 | 15-1 |
| Joint Types and Usage | 15-2 | 15-1 |
| Dowels | 15-3 | 15-17 |
| Special Provisions for Slipform Paving | 15-4 | 15-17 |
| Joint Sealing | 15-5 | 15-17 |
| Special Joints and Juncures | 15-6 | 15-17 |
| CHAPTER 16. JOINTS FOR REINFORCED CONCRETE | | |
| Requirements | 16-1 | 16-1 |
| Joint Sealing | 16-2 | 16-8 |
| CHAPTER 17. ROLLER-COMPACTED CONCRETE PAVEMENTS | | |
| Introduction | 17-1 | 17-1 |
| Load Transfer | 17-2 | 17-1 |
| Thickness Design | 17-3 | 17-1 |
| Multilift Pavements | 17-4 | 17-1 |
| Joint Types for RCC | 17-5 | 17-2 |
| CHAPTER 18. SEASONAL FROST CONDITIONS | | |
| General | 18-1 | 18-1 |
| Definitions | 18-2 | 18-2 |
| Frost-Susceptibility Classification | 18-3 | 18-4 |

| | <i>Paragraph</i> | <i>Page</i> |
|---|------------------|-------------|
| Alternative Methods of Thickness Design | 18-4 | 18-6 |
| Selection of Design Method | 18-5 | 18-6 |
| Limited Subgrade Frost Penetration | 18-6 | 18-6 |
| Reduced Subgrade Strength | 18-7 | 18-12 |
| Use of State Highway Requirements | 18-8 | 18-14 |
| Free-Draining Material Directly Beneath Bound Base or Surfacing Layer | 18-9 | 18-14 |
| Other Granular Unbound Base Course | 18-10 | 18-15 |
| Use of F1 and F2 Soils for Base Materials | 18-11 | 18-15 |
| Filter or Drainage Requirements | 18-12 | 18-15 |
| Stabilizers and Stabilized Layers | 18-13 | 18-15 |
| Stabilization with Lime and with LCF | 18-14 | 18-16 |
| Stabilization with Portland Cement | 18-15 | 18-16 |
| Stabilization with Bitumen | 18-16 | 18-16 |
| Subgrade Requirements | 18-17 | 18-16 |
| Other Measures to Reduce Heave | 18-18 | 18-18 |
| Pavement Cracking Associated with Frost Heave | 18-19 | 18-18 |
| Control of Subgrade and Base Course Construction | 18-20 | 18-18 |
| Base Course Construction | 18-21 | 18-19 |
| Compaction | 18-22 | 18-19 |
| Use of Insulation Materials in Pavements | 18-23 | 18-19 |
| Design Example-Heavily Trafficked Road | 18-24 | 18-19 |
| APPENDIX A. REFERENCES | | A-1 |
| APPENDIX B. DETERMINATION OF FLEXURAL STRENGTH AND MODULUS OF ELASTICITY OF BITUMINOUS CONCRETE | | B-1 |
| APPENDIX C. METHOD OF TEST FOR PERFORMED POLYCHLOROPRENE ELASTOMERIC JOINT SEAL JET-FUEL-RESISTANCE | | C-1 |
| APPENDIX D. USE OF INSULATION MATERIALS IN PAVEMENTS | | D-1 |
| APPENDIX E. COMPUTER AIDED DESIGN FOR FLEXIBLE ROAD PAVEMENTS/RIGID ROAD PAVEMENTS .. | | E-1 |

List of Figures

| <i>Figure No.</i> | <i>Title</i> | <i>Page</i> |
|-------------------|---|-------------|
| 8-1. | Flexible Pavement Design Curve for Roads and Streets | 8-2 |
| 8-2. | Equivalency Factors for Soils Stabilized with Cement, Lime or Cement and Lime Mixed with Flyash | 8-4 |
| 9-1. | Effect of Base-Course Thickness on Modulus of Soil Reaction | 9-3 |
| 12-1. | Design Curves for Plain Concrete Roads and Streets, and RCCP | 12-2 |
| 12-2. | Design Curve for Plain Concrete Parking and Open Storage Areas | 12-3 |
| 13-1. | Typical Layout of Joints at Intersection | 13-2 |
| 13-2. | Reinforced Rigid Pavement Design | 13-4 |
| 13-3. | Design Details of Reinforced Rigid Pavement with Two Traffic Lanes | 13-6 |
| 13-4. | Design Details of Reinforced Rigid Pavement with Traffic and Parking Lanes | 13-8 |
| 13-5. | Design Details of Reinforced Rigid Pavement with Integral Curb | 13-9 |
| 13-6. | Typical Layout of Joints at the Intersection of Reinforced Rigid Pavement | 13-11 |
| 14-1. | Factor for Projecting Cracking in a Flexible Pavement | 14-6 |
| 14-2. | Location Guide for the Use of Geotextiles in Retarding Reflective Cracking | 14-6 |
| 15-1. | Design Details for Plain Concrete Pavements | 15-2 |
| 15-2. | Joint Layout for Vehicular Parking Areas | 15-4 |
| 15-3. | Contraction Joints for Plain Concrete Pavements | 15-5 |
| 15-4. | Construction Joints for Plain Concrete Pavements | 15-6 |
| 15-5. | Expansion Joints for Plain Concrete Pavements | 15-10 |
| 15-6. | Thickened-Edge Slip Joint | 15-11 |
| 15-7. | Joint Sealant Details | 15-12 |
| 16-1. | Contraction Joints for Reinforced Concrete Pavements | 16-2 |
| 16-2. | Construction Joints for Reinforced Concrete Pavements | 16-3 |
| 16-3. | Expansion Joints for Reinforced Concrete Pavements | 16-7 |
| 18-1. | Determination of Freezing Index | 18-4 |
| 18-2. | Distribution of Design Freezing Index for North America | 18-8 |
| 18-3. | Frost Penetration Beneath Pavements | 18-9 |
| 18-4. | Design Depth of Nonfrost-Susceptible Base for Limited Subgrade Frost Penetration | 18-12 |
| 18-5. | Frost-Area Index of Reaction for Design of Rigid Roads, Streets, and Open Storage Areas | 18-14 |
| 18-6. | Tapered Transition Used Where Embankment Material Differs from Natural Subgrade in Cut | 18-18 |
| D-1. | Equivalent Sinusoidal Surface Temperature Amplitude A and Initial Temperature Difference V_0 | D-2 |
| D-2. | Thickness of Extruded Polystyrene Insulation to Prevent Subgrade Freezing | D-3 |
| D-3. | Effect of Thickness of Insulation and Base on Frost Penetration | D-4 |

List of Tables

| <i>Table No.</i> | <i>Title</i> | <i>Page</i> |
|------------------|---|-------------|
| 3-1. | Pavement Design Index | 3-2 |
| 4-1. | Depth of Compaction for Select Materials and Subgrades ($CBR \leq 20$) | 4-1 |
| 5-1. | Maximum Permissible Design Values for Subbases and Select Materials | 5-1 |
| 6-1. | Minimum Thickness of Pavement and Base Course | 6-2 |
| 8-1. | Equivalency Factors for Bituminous Stabilized Materials | 8-3 |
| 9-1. | Modulus of Soil Reaction | 9-2 |
| 15-1. | Maximum Allowable Spacing of Transverse Contraction Joints | 15-15 |
| 15-2. | Dowel Size and Spacing for Construction, Contraction, and Expansion Joints | 15-15 |
| 18-1. | Modes of Distress in Pavements | 18-2 |
| 18-2. | Frost Design Soil Classification | 18-5 |
| 18-3. | Frost-Area Soil Support Indexes for Subgrade Soils for Flexible Pavement Design | 18-13 |

CHAPTER 1

INTRODUCTION

1-1. Purpose.

This manual provides criteria for the design of pavements for roads, streets, walks, and open storage areas at U.S. Army and Air Force installations.

1-2. Scope.

This manual provides criteria for plain concrete, reinforced concrete, flexible pavements, and design for seasonal frost conditions. These criteria include subgrade and base requirements, thickness designs, and compaction requirements, criteria for stabilized layers, concrete pavement joint details, and overlays.

1-3. References.

Appendix A contains a list of references used in this manual.

1-4. Selection of Pavement Type.

Rigid pavements or composite pavements with a rigid overlay are required for the following areas.

- a. Vehicle Maintenance Areas.
- b. Pavements for All Vehicles with Nonpneumatic Tires.
- c. Open Storage Areas with Materials Having Nonpneumatic Loadings in Excess of 200 psi.
- d. Covered Storage Areas.
- e. Organizational Vehicle Parking Areas.
- f. Pavements Supporting Tracked Vehicles.
- g. Vehicle Wash Racks.
- h. Vehicle Fueling Pads.

Except for architectural or special operational requirements, all other pavements will be designed based upon life-cycle cost analysis.

1-5. Basis of Design.

a. *Design Variables.* The prime factor influencing the structural design of a pavement is the load-carrying capacity required. The thickness of pavement necessary to provide the desired load-carrying capacity is a function of the following five principal variables-

- (1) Vehicle wheel load or axle load.
- (2) Configuration of vehicle wheels or tracks.
- (3) Volume of traffic during the design life of pavement.
- (4) Soil strength.

(5) Modulus of rupture (flexural strength) for concrete pavements.

b. *Rigid Pavements.* The rigid pavement design procedure presented herein is based upon the critical tensile stresses produced within the slab by the vehicle loading. Correlation between theory, small-scale model studies, and full-scale accelerated traffic tests have shown that maximum tensile stresses in the pavement occur when the vehicle wheels are tangent to a free or unsupported edge of the pavement. Stresses for the condition of the vehicle wheels tangent to a longitudinal or transverse joint are less severe because of the use of load-transfer devices in these joints to transfer a portion of the load to the adjacent slab. Other stresses, because of their cyclic nature, will at times be additive to the vehicle load stresses and include restraint stresses resulting from thermal expansion and contraction of the pavement and warping stresses resulting from moisture and temperature gradients within the pavement. Provision for those stresses not induced by wheel loads is included in design factors developed empirically from full-scale accelerated traffic tests and from the observed performance of pavements under actual service conditions.

c. *Flexible Pavement.* The design procedure used by the Corps of Engineers and the Air Force to design flexible pavements is generally referred to as the California Bearing Ratio (CBR) design procedure. This procedure requires that each layer be thick enough to distribute the stresses induced by traffic so that when they reach the underlying layer they will not overstress and produce excessive shear deformation in the underlying layer. Each layer must also be compacted adequately so that traffic does not produce an intolerable amount of added compaction. Use ASTM D 1557 compaction effort procedures to design against consolidation under traffic.

1-6. Computer Aided Design.

In addition to the design procedures presented herein, computer programs are available for determining pavement thickness and compaction requirements for roads, streets, and open storage areas. These programs are contained on the floppy disk appendix E located in pocket to cover 3.

a. *Development.* Computer programs have been

TM 5-822-5/AFM 88-7, Chap. 1

developed to aid in the design of pavements for roads, streets, and open storage areas. The programs were developed on an IBM PC-AT using FORTRAN 77 as the development language with Microsoft's FORTRAN Compiler (version 3.2) and MS-DOS (version 3.1) as the operating system. Normally, the programs will be furnished as a compiled program which can be executed from floppy diskettes or hard drives. Thus far all the programs have been run on IBM PC-AT or IBM compatible microcomputers containing a minimum of 512K RAM.

b. Use of programs. In development of the computer programs, an effort was made to provide a user friendly program requiring no external instructions for use of the programs. Aside from instructions for initiating execution, which is standard for any executable program, the user is lead through the design procedure by a series of questions and informational screens. The input data required for pavement design by the program are

identical to the data required by the design manual, and the results obtained from the program should be close to the results obtained from the design curves. Because the computer program recalculates data and approximates certain empirical data, there may be some minor differences in results from the program and from the manual. If significant difference are obtained contact HQUSACE (CEMP-ET).

c. Program names. The flexible pavement road design program is FRD 904, and the rigid pavement design program is RRD 805. The numbers in the name refer to the date of the program. The first digit is the year of the revision. The last two digits of the program name is the month of the revision. Thus, the program FRD 904 is the flexible road design program that was revised in April 1989. Care should be taken that the latest version of the computer programs is being used. If there is doubt concerning a program, contact HQUSACE (CEMP-ET).

CHAPTER 2

PRELIMINARY INVESTIGATIONS

2-1. General.

The subgrade provides a foundation for supporting the pavement structure. As a result, the required pavement thickness and the performance obtained from the pavement during its design life will depend largely upon the strength and uniformity of the subgrade. Therefore, insofar as is economically feasible, a thorough investigation of the sub-grade should be made so that the design and construction will ensure uniformity of support for the pavement structure and realization of the maximum strength potential for the particular sub-grade soil type. The importance of uniformity of soil and moisture conditions under the pavement cannot be overemphasized with respect to frost action.

2-2. Investigations of Site.

Characteristics of subgrade soils and peculiar features of the site must be known to predict pavement performance. Investigations should determine the general suitability of the subgrade soils based on classification of the soil, moisture-density relation, degree to which the soil can be compacted, expansion characteristics, susceptibility to pumping, and susceptibility to detrimental frost action. Such factors as groundwater, surface infiltration, soil capillarity, topography, rainfall, and drainage conditions also will affect the future support rendered by the subgrade by increasing its moisture content and thereby reducing its strength. Past performance of existing pavements over a minimum of 5 years on similar local subgrades should be used to confirm the proposed design criteria. All soils should be classified according to the Unified Soil Classification Systems (USCS) in ASTM D 2487.

2-3. Soil Conditions.

a. General survey of subgrade conditions. Sources of data should include the landforms, soil

conditions in ditches, and cuts and tests of representative soils in the site. The survey should be augmented with existing soil and geological maps. Both natural and subsurface drainage of the sub-grade must be considered.

b. Preliminary subsurface explorations. Preliminary subsurface explorations should be made at intervals selected to test each type of soil and topography identified in the general survey. Additional subsurface explorations should be made in those areas where the preliminary investigation indicates unusual or potentially troublesome subgrade conditions. In determining subgrade conditions, borings will be carried to the depth of frost penetration, but no less than 6 feet below the finished grade. In the design of some high fills, it may be necessary to consider settlement caused by the weight of the fill. The depth requirements stated above will usually result in the subsurface explorations reaching below the depth of maximum frost penetration. If this is not the case, they should be extended to the maximum depth of frost penetration below the design grade as determined from chapter 10.

c. Soil. Soil samples from the preliminary borings should be classified and the data used to prepare soil profiles and to select representative soils for further testing. Measurements should include moisture contents which indicate soft layers in the soil.

2-4. Borrow Areas.

Where material is to be borrowed from adjacent areas, subsurface explorations should be made in these areas and carried 2 to 4 feet below the anticipated depth of borrow. Samples from the explorations should be classified and tested for moisture content and compactions characteristics.

CHAPTER 3

VEHICULAR TRAFFIC

3-1. Effect on Pavement Design.

Pavement thickness must be designed to withstand the anticipated traffic, categorized by type and weight of vehicles, and measured by average daily volume (ADV) of each type for the design life of the pavement. For most pavements, the magnitude of the axle load is of greater importance than the gross weight of pneumatic-tired vehicles because axle spacings are generally so large that there is little interaction between the wheel loads of one axle and the wheel loads of the other axles. Thus, for the case of pneumatic-tired vehicles having equal axle loads, the increased severity of loading imposed by conventional four- or five-axle trucks as compared with that imposed by two- or three-axle trucks is largely a fatigue effect resulting from an increased number of load repetitions per vehicle operation. For forklift trucks where the loading is concentrated largely on a single axle and for tracked vehicles where the loading is evenly divided between the two tracks, the severity of the vehicle loading is a function of the gross weight of the vehicle and the frequency of loading. Relations between load repetition and required rigid pavement thickness developed from accelerated traffic tests of full-scale pavements have shown that, for any given vehicle, increasing the gross weight by as little as 10 percent can be equivalent to increasing the volume of traffic by as much as 300 to 400 percent. On this basis, the magnitude of the vehicle loading must be considered as a more significant factor in the design of pavements than the number of load repetitions.

3-2. Traffic Evaluation.

Procedures for the evaluation of traffic and selection of design index are as follows.

a. Pneumatic-tired vehicles. To aid in evaluating vehicular traffic for the purpose of pavement design, pneumatic-tired vehicles have been divided into the following three groups —

Group 1. Passenger cars, panel trucks, and pickup trucks

Group 2. Two-axle trucks

Group 3. Three-, four-, and five-axle trucks

The design weights for various pneumatic-tired vehicles have been based on average weights, as determined from Federal Highway Administration traffic surveys made on public highways, plus one-fourth of the difference between these average

weights and the maximum allowable weights. For group 2 and group 3 vehicles, maximum allowable weights are based on single-axle and tandem-axle loadings not exceeding 18,000 and 32,000 pounds, respectively. Since traffic rarely will be composed of vehicles from a single group, pneumatic-tired vehicular traffic has been classified into five general categories based on the distribution of vehicles from each of the three groups listed above. These traffic categories are defined as follows —

Category I. Traffic composed primarily of passenger cars, panel and pickup trucks (group 1 vehicles), but containing not more than 1 percent two-axle trucks (group 2 vehicles).

Category II. Traffic composed primarily of passenger cars, panel and pickup trucks (group 1 vehicles), but may contain as much as 10 percent two-axle trucks (group 2 vehicles). No trucks having three or more axles (group 3 vehicles) are permitted in this category.

Category III. Traffic containing as much as 15 percent trucks, but with not more than 1 percent of the total traffic composed of trucks having three or more axles (group 3 vehicles).

Category IV. Traffic containing as much as 25 percent trucks, but with not more than 10 percent of the total traffic composed of trucks having three or more axles (group 3 vehicles).

Category IVA. Traffic containing more than 25 percent trucks.

b. Tracked vehicles and forklift trucks. Tracked vehicles having gross weights not exceeding 15,000 pounds and forklift trucks having gross weights not exceeding 6,000 pounds may be treated as two-axle trucks (group 2 vehicles) and substituted for trucks of this type in the traffic categories defined above on a one-for-one basis. Tracked vehicles having gross weights exceeding 15,000 pounds but not 40,000 pounds and forklift trucks having gross weights exceeding 6,000 pounds but not 10,000 pounds may be treated as group 3 vehicles and substituted for trucks having three or more axles in the appropriate traffic categories on a one-for-one basis. Traffic composed of tracked vehicles exceeding 40,000 pounds gross weight and forklift trucks exceeding 10,000 pounds gross weight has been divided into the following three categories —

Maximum Vehicle Gross Weight, Pounds

| Category | Tracked Vehicles | Forklift Trucks |
|----------|------------------|-----------------|
| V..... | 60,000 | 15,000 |
| VI..... | 90,000 | 25,000 |
| VII..... | 130,000 | (*) |

* Forklift trucks exceeding 25,000-pounds gross weight are treated in TM 5-809-12/AFM 88-3, Chap. 15.

c. *Selection of design index.* The design of pavements for Army and Air Force roads, streets, and similar areas is based on a “design index,” which represents the combined effect of the loads defined by the traffic categories just described and the traffic volumes associated with each of the lettered classifications of roads or streets. This index extends from one through ten with an

increase in numerical value indicative of an increase in pavement design requirements. Table 3-1 gives the appropriate design index for combinations of the eight traffic categories based on distribution of traffic, vehicle type, and the six-letter classifications based on the volume of traffic. For example, suppose an average daily traffic (ADT) of 2,000 vehicles composed primarily of passenger cars, panel trucks, and pickup trucks (group 1), but including 100 two-axle trucks (group 2) is anticipated for a road in flat terrain. First, the road class is determined from TM 5-822-2/AFM 88-7, Chap. 5 to be a class D road. Second, the group 2 vehicles are 100/2,000 or 5 percent of the total of groups 1 and 2, making this category II traffic. Therefore, the appropriate design index from table 3-1 is 2.

Table 3-1. Pavement Design Index

| Traffic Category | Pavement Design Index for Road or Street Classification | | | | | |
|---|---|----|----|----|----|-----|
| | A | B | C | D | E | F |
| I..... | 2 | 2 | 2 | 1 | 1 | 1 |
| II..... | 3 | 2 | 2 | 2 | 2 | 1 |
| III..... | 4 | 4 | 4 | 3 | 3 | 2 |
| IV..... | 5 | 5 | 5 | 4 | 4 | 3 |
| IVA..... | 6 | 6 | 6 | 5 | 5 | 4 |
| V (60-kilopound (kip) track-laying vehicles or 15 kip forklifts)..... | 7 | 7 | 7 | 7 | 7 | (*) |
| 500/day..... | 6 | 6 | 6 | 6 | 6 | (*) |
| 200/day..... | 6 | 6 | 6 | 6 | 6 | (*) |
| 100/day..... | 6 | 6 | 6 | 6 | 6 | 6 |
| 40/day..... | 6 | 6 | 6 | 5 | 5 | 5 |
| 10/day..... | 5 | 5 | 5 | 5 | 5 | 5 |
| 4/day..... | 5 | 5 | 5 | 5 | 4 | 4 |
| 1/day..... | 5 | 5 | 5 | 4 | 4 | 4 |
| VI (90-kip track-laying vehicles or 25 kip forklifts) | | | | | | |
| 200/day..... | 9 | 9 | 9 | 9 | 9 | (*) |
| 100/day..... | 8 | 8 | 8 | 8 | 8 | 8 |
| 40/day..... | 7 | 7 | 7 | 7 | 7 | 7 |
| 10/day..... | 6 | 6 | 6 | 6 | 6 | 6 |
| 4/day..... | 6 | 6 | 6 | 6 | 6 | 6 |
| 1/day..... | 5 | 5 | 5 | 5 | 5 | 5 |
| 1/week..... | 5 | 5 | 5 | 4 | 4 | 4 |
| VII (120-kip track laying vehicles): | | | | | | |
| 100/day..... | 10 | 10 | 10 | 10 | 10 | 10 |
| 40/day..... | 9 | 9 | 9 | 9 | 9 | 9 |
| 10/day..... | 8 | 8 | 8 | 8 | 8 | 8 |
| 4/day..... | 7 | 7 | 7 | 7 | 7 | 7 |
| 1/day..... | 6 | 6 | 6 | 6 | 6 | 6 |
| 1/week..... | 5 | 5 | 5 | 5 | 5 | 5 |

* Traffic limited to 100 vehicles per day.

(1) *Tracked vehicles and forklift trucks.* Provision is made whereby the designer may determine pavement design requirements for tracked vehicles or forklifts in combination with traffic by pneumatic-tired vehicles or for traffic by tracked vehicles or forklifts only. Where pneumatic-

tired vehicles, forklifts, and tracked vehicles are to be considered, the proper letter classification of the road or street is determined from TM 5-822-2/AFM 88-7, Chapter 5 according to the total volume of traffic from all types of vehicles. In table 3-1 the traffic for categories V, VI, and VII has been

divided further into various levels of frequency. If the tracked vehicle or forklift traffic is composed of vehicles from more than a single traffic category, it will be necessary for the designer to determine the anticipated frequency of traffic in each category in order to determine the appropriate design index. For example, 40 vehicles per day of category VI traffic require a greater pavement design index than does one vehicle per day of category VII traffic. Thus, the designer cannot rely on maximum gross weight alone to determine pavement design index values. For vehicular parking areas, the design index

should be determined from the column for class E roads or streets, again taking into account the relative traffic frequencies where there are vehicles from more than a single traffic category.

(2) *Special-Purpose Vehicles.* Information regarding pavement design requirements for special purpose vehicles producing loadings significantly greater than those defined in this manual will be requested from Headquarters, US Army Corps of Engineers (CEMP-ET), or the appropriate Air Force Major Command.

CHAPTER 4

FLEXIBLE PAVEMENT SUBGRADES

4-1. Factors To Be Considered.

The information obtained from the explorations and tests previously described should be adequate to enable full consideration of all factors affecting the suitability of the subgrade and subsoil. The primary factors are as follows:

- a. The general characteristics of the subgrade soils such as soil classification, limits, etc.
- b. Depth to bed rock.
- c. Depth to water table (including perched water table).
- d. The compaction that can be attained in the subgrade and the adequacy of the existing density in the layers below the zone of compaction requirements.
- e. The CBR that the compacted subgrade and uncompacted subgrade will have under local environmental conditions.
- f. The presence of weak or soft layers in the sub-soil.
- g. Susceptibility to detrimental frost action.

4-2. Compaction.

The natural density of the subgrade must be sufficient to resist densification under traffic or the subgrade must be compacted during construction to a depth where the natural density will resist densification under traffic. Table 4-1 shows the depth, measured from the pavement surface, at which a given percent compaction is required to prevent densification under traffic. Subgrades in cuts must have natural densities equal to or greater than the values shown in table 4-1. Where such is not the case, the subgrade must be compacted from the surface to meet the tabulated densities, or be removed and replaced in which case the requirements for fills apply, or be covered with sufficient select material, subbase, and base so that the uncompacted subgrade is at a depth where the in-place densities are satisfactory. In fill areas, cohesionless soils will be placed at no less than 95 percent of ASTM D 1557 maximum density nor cohesive fills at less than 90 percent of ASTM D 1557 maximum density.

Table 4-1. Depth of Compaction for Select Materials and Subgrades (CBR ≤ 20).

| Design index | Depth of compaction* for percent compaction shown, in. | | | | | | | | | |
|--------------|--|----|----|----|----|------------------------------------|----|----|----|----|
| | Cohesive soils PI > 5; LL > 25 | | | | | Cohesionless soils PI ≤ 5; LL ≤ 25 | | | | |
| | 100 | 95 | 90 | 85 | 80 | 100 | 95 | 90 | 85 | 80 |
| 1..... | 3 | 7 | 10 | 14 | 17 | 7 | 13 | 19 | 25 | 33 |
| 2..... | 4 | 8 | 12 | 16 | 20 | 8 | 15 | 22 | 29 | 38 |
| 3..... | 4 | 9 | 14 | 18 | 23 | 9 | 17 | 25 | 33 | 43 |
| 4..... | 5 | 11 | 16 | 21 | 26 | 11 | 20 | 28 | 37 | 48 |
| 5..... | 6 | 12 | 18 | 23 | 28 | 12 | 22 | 31 | 40 | 53 |
| 6..... | 7 | 14 | 19 | 25 | 31 | 14 | 24 | 35 | 44 | 58 |
| 7..... | 7 | 15 | 21 | 28 | 34 | 15 | 26 | 38 | 48 | 63 |
| 8..... | 8 | 16 | 23 | 30 | 37 | 16 | 29 | 41 | 52 | 68 |
| 9..... | 9 | 18 | 25 | 32 | 40 | 18 | 31 | 44 | 56 | 74 |
| 10..... | 10 | 20 | 28 | 35 | 43 | 20 | 34 | 47 | 59 | 77 |

* Depth of compaction is measured from pavement surface.

4-3. Compaction Example.

An example illustrating the application of sub-grade compaction requirements is as follows:

- a. *Cohesion less subgrade.* Assume a clean cohesionless sand and a design CBR of 18, with a natural in-place density of 90 percent of maximum density to beyond the depth of exploration of 6 feet. From table 4-1 for a design index of 5, it is found that 100 percent density must extend to a depth of

12 inches below the pavement surface. Below this depth, fill sections must be compacted to 95 percent maximum density throughout, and cut sections to 95 percent of maximum density to a depth of 22 inches below the pavement surface. The designer must decide from previous experience or from test-section data whether or not these percentages of compaction in cut sections can be obtained from the top of the subgrade. If they cannot, a part of the subgrade must be removed, the underlying layer

compacted, and the material replaced, or the thickness of select material or subbase must be so increased that the densities in the uncompacted subgrade will be adequate.

b. Cohesive subgrade. Assume a lean clay, a design CBR of 7, and a natural in-place density of 83 percent of maximum density extending below the depth of exploration of 6 feet. Compaction of the subgrade from the surface would be impracticable with ordinary equipment beyond the 6- to 8-inch depth that could be processed; therefore, the minimum depth of cut would be limited by the in-place density. From table 4-1 for a design index of 5, it is found that the 83 percent in-place natural density would be satisfactory below depths of about 25 inches from the pavement surface. From CBR design curves (explained subsequently), the top of the subgrade will be 14.5 inches below the pavement surface; therefore, a zone 10.5 inches thick below the top of the subgrade requires treatment. The bottom 6 to 8 inches of this can be processed in place; so about 4 inches of material must be removed and replaced. Compaction to 95 percent of maximum density is required for all cohesive material that lies within 12 inches of the pavement surface. Since the subgrade does not fall within this zone compaction requirements in the replaced material should be 90 percent to conform to fill requirements, and the layer processed in place

should be 85 percent of maximum density to conform to fill requirements.

4-4. Selection of Design CBR Values.

Flexible pavements may be designed using the laboratory soaked CBR, the field in-place CBR, or the CBR from undisturbed samples as described in MIL-STD-621A, Method 101. For the design of flexible pavements in areas where no previous experience regarding pavement performance is available, the laboratory soaked CBR is normally used. Where an existing pavement is available at the site that has a subgrade constructed to the same standards as the job being designed, in-place tests or tests on undisturbed samples may be used in selecting the design CBR value. In-place tests are used when the subgrade material is at the maximum water content expected in the prototype. Contrarily, tests on undisturbed samples are used where the material is not at the maximum water content and thus soaking is required. Sampling involves considerably more work than in-place tests; also, "undisturbed" samples tend to be slightly disturbed; therefore, in-place tests should be used where possible. Guides for determining when in-place tests can be used are given in details of the CBR test in MIL-STD-621A, Test Method 101.

CHAPTER 5

FLEXIBLE PAVEMENT SELECT MATERIALS AND SUBBASE COURSES

5-1. General.

It is common practice in pavement design to use locally available or other readily available materials between the subgrade and base course for economy. These layers are designated in this manual as select materials or subbases. Those with design CBR values equal to or less than 20 are designated select materials, and those with CBR values above 20 are designated subbases. Minimum thicknesses of pavement and base have been established to eliminate the need for subbases with design CBR values above 50. Where the design CBR value of the subgrade without processing is in the range of 20 to 50, select materials and subbases may not be needed. However, the subgrade cannot be assigned design CBR values of 20 or higher unless it meets the gradation and plasticity requirements for subbases.

5-2. Materials.

The investigations described in chapter 2 will be used to determine the location and characteristics of suitable soils for select material and subbase construction.

a. Select materials. Select materials will normally be locally available coarse-grained soils (prefix G or S), although fine-grained soils in the ML and CL groups may be used in certain cases. Limerock, coral, shell, ashes, cinders, caliche, disintegrated granite, and other such materials should be considered when they are economical. Recommended plasticity requirements are listed in table 5-1. A maximum aggregate size of 3 inches is suggested to aid in meeting grading requirements.

Table 5-1. Maximum Permissible Design Values for Subbases and Select Materials.

| Material | De- sign CBR | Size in. | Gradation requirements,* % passing | | Liquid Limit | Plas- ticity Index |
|-----------------------|--------------------|-------------|--|------------|-----------------|--------------------------|
| | | | No. 10 | No. 200 | | |
| Subbase | 50 | 3 | 50 | 15 | 25 | 5 |
| Subbase | 40 | 3 | 80 | 15 | 25 | 5 |
| Subbase | 30 | 3 | 100 | 15 | 25 | 5 |
| Select material | 20 | *3 | | **25 | **35 | **12 |

* Cases may occur in which certain natural materials that do not meet the gradation requirements may develop satisfactory CBR values in the prototype. Exceptions to the gradation requirements are permissible when supported by adequate in-place CBR tests on construction that has been in service for several years. The CBR test is not applicable for use in evaluating materials stabilized with additives.

** Suggested limits.

b. Subbase materials. Subbase materials may consist of naturally occurring coarse-grained soils or blended and processed soils. Materials such as limerock, coral, shell, ashes, cinders, caliche, and disintegrated granite may be used as subbases when they meet the requirements described in table 5.4. The existing subgrade may meet the requirements for a subbase course or it may be possible to treat the existing subgrade to produce a subbase. However, admixing native or processed materials will be done only when the unmixed subgrade meets the liquid limit and plasticity index requirements for subbases. It has been found that "cutting" plasticity

in this way is not satisfactory. Material stabilized with commercial additives may be economical as a subbase. Portland cement, lime, flyash, or bitumen and combinations thereof are commonly employed for this purpose. Also, it may be possible to decrease the plasticity of some materials by use of lime or portland cement in sufficient amounts to make them suitable as subbases.

5-3. Compaction.

These materials can be processed and compacted with normal procedures. Compaction of subbases will be 100 percent of ASTM D 1557 density

TM 5-822-5/AFM 88-7, Chap. 1

except where it is known that a higher density can be obtained practically, in which case the higher density should be required. Compaction of select materials will be as shown in table 4-1 except that in no case will cohesionless fill be placed at less than 95 percent or cohesive fill at less than 90 percent.

5-4. Drainage.

Subbase drainage is an important aspect of design and should be accomplished in accordance with TM 5-820-2/AFM 88-5, Chap. 2.

5-5. Selection of Design CBR Values.

The select material or subbase will generally be uniform, and the problem of selecting a limiting condition, as described for the subgrade, does not ordinarily exist. Tests are usually made on remolded samples; however, where existing similar con-

struction is available, CBR tests may be made in place on material when it has attained its maximum expected water content or on undisturbed soaked samples. The procedures for selecting CBR design values described for subgrades apply to select materials and subbases. CBR tests on gravelly materials in the laboratory tend to give CBR values higher than those obtained in the field. The difference is attributed to the processing necessary to test the sample in the 6-inch mold, and to the confining effect of the mold. Therefore, the CBR test is supplemented by gradation and Atterberg limits requirements for subbases, as shown in table 5-1. Suggested limits for select materials are also indicated. In addition to these requirements, the material must also show in the laboratory tests a CBR equal to or higher than the CBR assigned to the material for design purposes.

CHAPTER 6

FLEXIBLE PAVEMENT BASE COURSES

6-1. Materials. High-quality materials must be used in base courses of flexible pavements. These high-quality materials provide resistance to the high stresses that occur near the pavement surface. Guide specifications for graded crushed aggregate, limerock, and stabilized aggregate may be used without qualification for design of roads, streets, and parking areas. Guide specifications for dry- and water-bound macadam base courses may be used for design of pavements only when the cost of the dry- or water-bound macadam base does not exceed the cost of stabilized-aggregate base course, and the ability of probable bidders to construct pavements with dry- or water-bound macadam base to the required surface smoothness and grade tolerances has been proved by experience in the area.

6-2. Compaction. Base courses placed in flexible pavements should be compacted to the maximum density practicable, generally in excess of 100 percent of ASTM D 1557 maximum density but never less than 100 percent of ASTM D 1557 maximum density.

6-3. Drainage. Drainage design for base courses should be accomplished in accordance with TM 5-820-2/AFM 88-5, Chap. 2.

6-4. Selection of Design CBR. Because of the effects of processing samples for the laboratory CBR tests and because of the effects of the test

mold, the laboratory CBR test will not be used in determining CBR values of base courses. In-stead, selected CBR ratings will be assigned as shown in the following tabulation. These ratings have been based on service behavior records and, where pertinent, on in-place tests made on materials that had been subjected to traffic. It is imperative that the materials conform to the quality requirements given in the guide specifications so that they will develop the needed strengths.

| No. | Type | De- sign CBR |
|-----|--|--------------------|
| 1 | Graded crushed aggregate | 100 |
| 2 | Water-bound macadam | 100 |
| 3 | Dry-bound macadam | 100 |
| 4 | Bituminous binder and surface courses, central plant, hot mix. | 100 |
| 5 | Limerock | 80 |
| 6 | Stabilized aggregate | 80 |

6-5. Minimum Thickness. The minimum allowable thickness of base course will be 4 inches as shown in table 6-1, except that in no case will the total thickness of pavement plus base for class A through D roads and streets be less than 6 inches nor less than frost design minimum specified in chapter 18 when frost conditions are controlling. TM 5-822-5/AFM 88-7, Chap. 1

Table 6-1. Minimum Thickness of Pavement and Base Course.

| Design index | Minimum Base Course CBR | | | | | | | | |
|--------------|-------------------------|----------|-----------|--------------|----------|-----------|--------------|----------|-----------|
| | 100 | | | 80 | | | 50* | | |
| | Pavement in. | Base in. | Total in. | Pavement in. | Base in. | Total in. | Pavement in. | Base in. | Total in. |
| 1 | ST** | 4 | 4-1/2† | MST†† | 4 | 4-1/2† | 2 | 4 | 6 |
| 2 | MST†† | 4 | 5† | 1-1/2 | 4 | 5-1/2† | 2-1/2 | 4 | 6-1/2 |
| 3 | 1-1/2 | 4 | 5-1/2† | 1-1/2 | 4 | 5-1/2† | 2-1/2 | 4 | 6-1/2 |
| 4 | 1-1/2 | 4 | 5-1/2† | 2 | 4 | 6 | 3 | 4 | 7 |
| 5 | 2 | 4 | 6 | 2-1/2 | 4 | 6-1/2 | 3-1/2 | 4 | 7-1/2 |
| 6 | 2-1/2 | 4 | 6-1/2 | 3 | 4 | 7 | 4 | 4 | 8 |
| 7 | 2-1/2 | 4 | 6-1/2 | 3 | 4 | 7 | 4 | 4 | 8 |
| 8 | 3 | 4 | 7 | 3-1/2 | 4 | 7-1/2 | 4-1/2 | 4 | 8-1/2 |
| 9 | 3 | 4 | 7 | 3-1/2 | 4 | 7-1/2 | 4-1/2 | 4 | 8-1/2 |
| 10 | 3-1/2 | 4 | 7 | 4 | 4 | 8 | 5 | 4 | 9 |

* In general 50-CBR base course will only be used for classes E and F roads and streets.

** Bituminous surface treatment (spray application).

† Minimum total thickness of pavement plus base for classes A through D roads and streets will be 6 inches.

†† Multiple bituminous surface treatment (spray application).

CHAPTER 7

BITUMINOUS PAVEMENT

7-1. General.

The bituminous materials used in paving are asphaltic or tar products as listed in TM 5-822-8/AFM 88-6, Chap 9. Although asphalts and tars resemble each other in general appearance, they do not have the same physical or chemical characteristics. Tars are affected to a greater extent by temperature changes and weather conditions; however, they tend to have better adhesive and penetrating properties than asphalts. Generally asphalt surface courses are preferred to tar surface courses. The selection of the type of bituminous material (asphalt

or tar) should normally be based on economy.

7-2. Criteria for Bituminous Pavements.

The basic criteria for selection and design of bituminous pavements are contained in TM 5-822-8 which includes the following criteria:

- a.* Selection of bitumen type.
- b.* Selection of bitumen grade.
- c.* Aggregate requirements.
- d.* Quality requirements.
- e.* Types of bituminous pavements.

CHAPTER 8

FLEXIBLE PAVEMENT DESIGN

8-1. General.

Flexible pavement designs will provide the following:

- a. Sufficient compaction of the subgrade and of each layer during construction to prevent objectionable settlement under traffic.
- b. Adequate drainage of base course.
- c. Adequate thickness above the subgrade and above each layer together with adequate quality of the select material, subbase, and base courses to prevent detrimental shear deformation under traffic and, when frost conditions are a factor, to control or reduce to acceptable limits effects of frost heave or permafrost degradation.
- d. A stable, weather-resistant, wear-resistant waterproof, nonslippery pavement.

8-2. Design Procedure.

a. *Conventional flexible pavements.* In designing conventional flexible pavement structures, the design values assigned to the various layers are applied to the curves and criteria presented herein. Generally, several designs are possible for a specific site, and the most practical and economical design is selected. Since the decision on the practicability of a particular design may be largely a matter of judgment, full particulars regarding the selection of the final design (including cost estimates) will be included in the design analysis. For computer aided design, see paragraph 1-6.

b. *Stabilized Soil Layers.* Flexible pavements containing stabilized soil layers are designed through the use of equivalency factors. A conventional flexible pavement is first designed and the equivalency factors applied to the thickness of the layer to be stabilized. When stabilized materials meeting all gradation, durability, and strength requirements indicated in TM 5-822-4, and in chapter 17 herein are utilized in pavement structures, an appropriate equivalency factor may be applied. Soils which have been mixed with a stabilizing agent and which do not meet the requirements for a stabilized soil are considered modified and are designed as conventional pavement layers. When portland cement is used to stabilize base course materials in Air Force Pavements, the treatment level must be maintained below approximately 4 percent by weight to minimize shrinkage cracking which will reflect through the bituminous concrete surface course. In this case, the base course will, in most

instances, be modified rather than stabilized. In addition, when unbound granular layers are employed between two bound layers (e.g., an unbound base course between an asphalt concrete (AC) surface course and a stabilized subbase course), it is imperative that adequate drainage be provided the unbound layer to prevent entrapment of excessive moisture in the layer. Additional information on soil stabilization may be - obtained from TM 5-818-1.

c. *All-bituminous concrete.* All-bituminous concrete pavements are also designed using equivalency factors (see para 8-6). The procedure is the same as for stabilized soil layers discussed above.

8-3. Design Index.

The design of flexible pavements for roads, streets, parking areas, open storage, and similar areas will be based on a design index, which is an index representing all traffic expected to use a flexible pavement during its life. It is based on typical magnitudes and compositions of traffic reduced to equivalents in terms of repetitions of an 18,000-pound, single-axle, dual-tire load. Selection of the design index will be accomplished as stated in chapter 3. The designer is cautioned that in selecting the design index, consideration will be given to traffic which may use the pavement structure during various stages of construction and to other foreseeable exceptional use.

8-4. Thickness Criteria-Conventional Flexible Pavements.

Thickness design requirements are given in figure 8-1 in terms of CBR and design index. Minimum thickness requirements are shown in table 6-1. For frost condition design, thickness requirements will be determined from chapter 18 of this manual. In regions where the annual precipitation is less than 15 inches and the water table (including perched water table) will be at least 15 feet below the finished pavement surface, the danger of high moisture content in the subgrade is reduced. Where in-place tests on similar construction in these regions indicate that the water content of the subgrade will not increase above the optimum, the total pavement thickness, as determined by CBR tests on soaked samples, may be reduced by as much as 20 percent. The minimum thickness of pavement and base course must still be met; there-

fore the reduction Will be affected in the subbase course immediately above the subgrade. when only limited rainfall records are available, or the annual precipitation is close to the 15-inch criterion, careful

consideration will be given to the sensitivity of the subgrade to small increases in moisture content before any reduction in thickness is made.

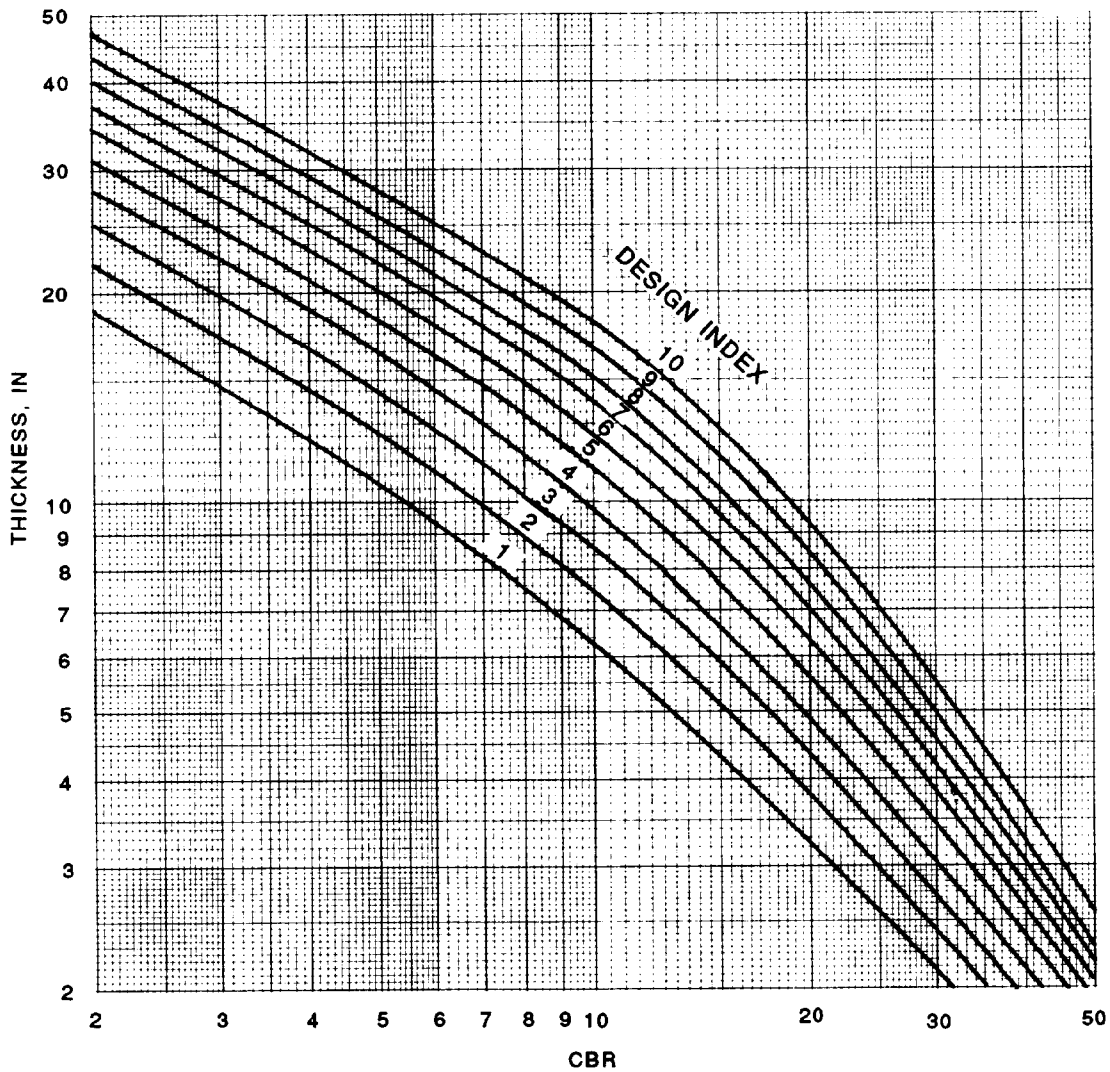

Figure 8-1. Flexible Pavement Design Curve for Roads and Streets.

8-5. Example Thickness Design-Conventional Flexible Pavements.

This example illustrates design by the CBR method when the subgrade, subbase, or base course materials are not affected by frost. Assume that a design is to be prepared for a road that will require a design index of 5. Further assume that compaction

requirements will necessitate an increase in subgrade density to a depth of 9 inches below the subgrade surface and that a soft layer occurs within the subgrade 24 inches below the subgrade surface. The CBR design values of the various subgrade layers and the materials available for subbase and base course construction are as follows:

| Material | Soil Classification | Design CBR |
|------------------------------|---------------------|------------|
| Weak layer in subgrade | CH | 4 |
| Natural subgrade | CL | 7 |
| Compacted subgrade | CL | 10 |
| 1 | GP | 35 |
| 2 | GM (limerock) | 80 |

The total thickness and thicknesses of the various subbase and base layers are determined as follows:

a. *Total thickness.* The total thickness of subbase, base, and pavement will be governed by the CBR of the compacted subgrade. From the flexible-pavement design curves shown in figure 8-1, the required total thickness above the compacted subgrade (CBR of 10) is 11 inches. A check must be made of the adequacy of the strength of the uncompacted subgrade and of the weak layer within the subgrade. From the curves in figure 8-1, the required cover for these two layers is 14.5 and 21 inches, respectively. If the design thickness is 11 inches and the subgrade is compacted to 9 inches below the subgrade surface, the natural subgrade will be covered by a total of 20 inches of higher strength material. Similarly, the soft layer occurring 24 inches below the subgrade surface will be protected by 35 inches of total cover. Thus, the cover is adequate in both cases.

b. *Minimum base and pavement thicknesses.* For a design index of 5 the minimum base thickness is 4 inches and the pavement thickness is 2½ inches as indicated in table 6-1. If, however, the CBR of the base material had been 100 rather than 80, a minimum pavement thickness of 2 inches would have been required.

c. *Thickness of subbase and base courses.* The design thickness of each layer of materials 1 and 2 will depend upon the CBR design value of each material. The total thickness of subbase, base, and pavement, as determined above, is 11 inches. The thickness required above material 1 (CBR = 35), as determined from figure 8-1, is 3 inches; therefore, the required thickness of material 1 is 8 inches (11 - 3 inches). The 3-inch layer required above material 1 will be composed of material 2 and pavement; however, adjustments must be made in the thicknesses of material 2 and the pavement to conform with minimum base and pavement thickness, which is a combined thickness of

pavement and base of 6½ inches (2½ inches of pavement and 4 inches of base). Therefore, the section using materials 1 and 2 will consist of a 4.5-inch subbase course of material 1, a 4-inch base course of material 2, and a 2½-inch pavement.

8-6. Thickness Criteria-Stabilized Soil Layers.

a. *Equivalency factors.* The use of stabilized soil layers within a flexible pavement provides the opportunity to reduce the overall thickness of pavement structure required to support a given load. To design a pavement containing stabilized soil layers requires the application of equivalency factors to a layer or layers of a conventionally designed pavement. To qualify for application of equivalency factors, the stabilized layer must meet appropriate strength and durability requirements set forth in TM 5-822-4. An equivalency factor represents the number of inches of a conventional base or subbase which can be replaced by 1 inch of stabilized material. Equivalency factors are determined as shown in table 8-1 for bituminous stabilized materials, and from figure 8-2 for materials stabilized with cement, lime, or a combination of flyash mixed with cement or lime. Selection of an equivalency factor from the tabulation is dependent upon the classification of the soil to be stabilized. Selection of an equivalency factor from figure 8-2 requires that the unconfined compressive strength as determined in accordance with ASTM D 1633 be known. Equivalency factors are determined from figure 8-2 for subbase materials only. The relationship established between a base and subbase is 2 to 1. Therefore, to determine an equivalency factor for a stabilized base course, divide the subbase factor from figure 8-2 by 2.

Table 8-1. *Equivalency Factors for Bituminous Stabilized Materials.*

| Material | Equivalency Factors | |
|-------------------------------|---------------------|----------|
| | Base | Sub-base |
| All-bituminous concrete | 1.15 | 2.30 |
| GW, GP, GM, GC | 1.00 | 2.00 |
| SW, SP, SM, SC | (*) | 1.50 |

*Not used for base course material.

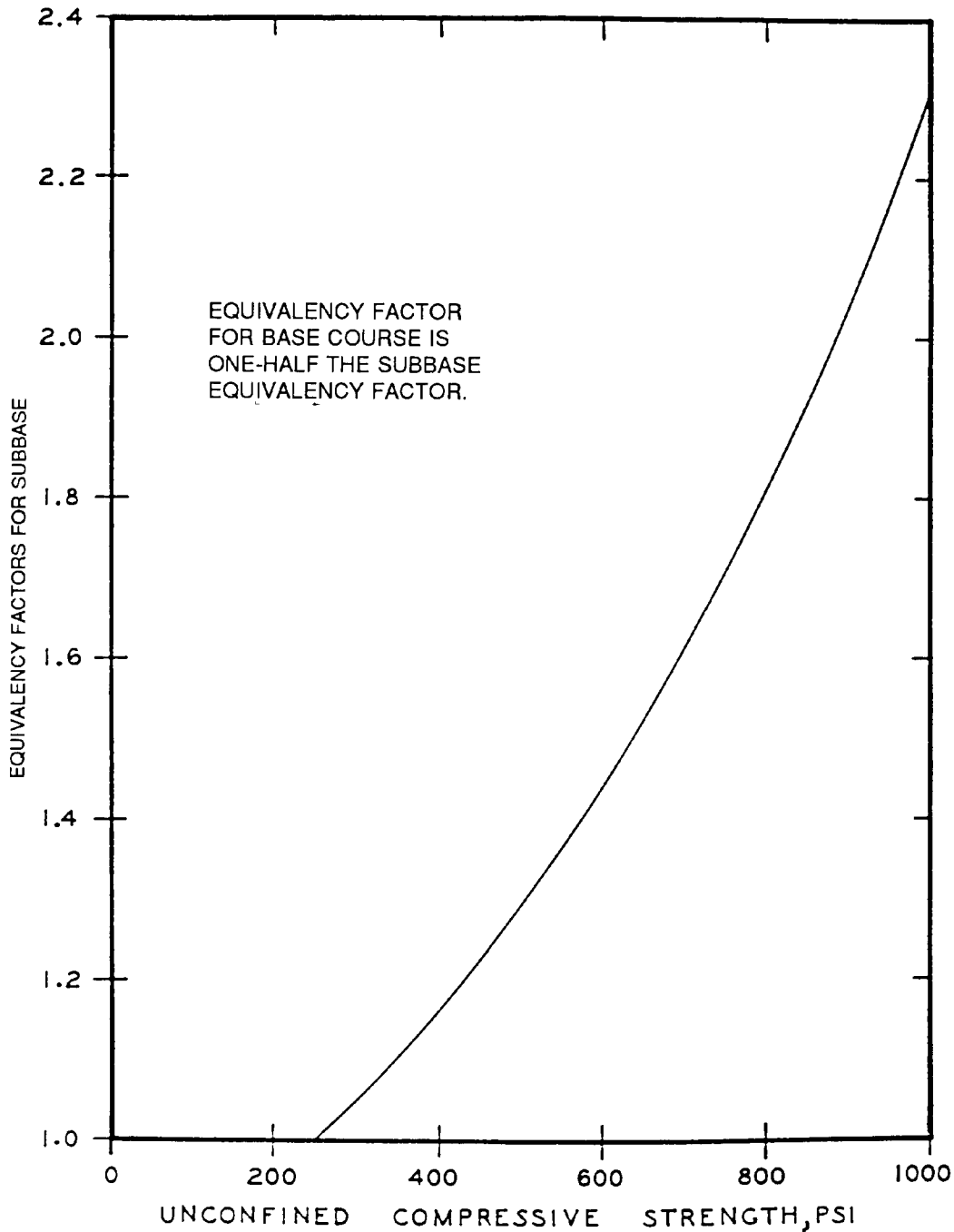

Figure 8-2. Equivalency Factors for Soils Stabilized with Cement, Lime, or Cement and Lime Mixed with Flyash.

b. *Minimum thickness.* The minimum thickness requirements for a stabilized base or subbase is 4 inches. The minimum thickness requirements for the asphalt pavement are the same as shown for conventional pavements in table 6-1.

8-7. Example Thickness Design-Stabilized Soil Layers.

To use the equivalency factors requires that a conventional flexible pavement be designed to support the design load conditions. If it is desired to use a

stabilized base or subbase course, the thickness of conventional base or subbase is divided by the equivalency factor for the applicable stabilized soil. Examples for the application of the equivalency factors are as follows—

a. Example 1. Assume a conventional flexible pavement has been designed which requires a total thickness of 16 inches above the subgrade. The minimum thickness of AC and base is 2 and 4 inches, respectively, and the thickness of subbase is 10 inches. It is desired to replace the base and subbase with a cement-stabilized gravelly soil having an unconfined compressive strength of 890 psi. From figure 8-2 the equivalency factor for a subbase having an unconfined compressive strength of 890 is 2.0. Therefore, the thickness of stabilized subbase is 10 inches ÷ 2.0 = 5.0 inches. To calculate the thickness of stabilized base course, divide the subbase equivalency factor by 2 and then divide the unbound base course thickness by the result. Therefore, 4 inches ÷ 1.0 = 4.0 inches of stabilized base course. The final section would be 2 inches of AC and 9 inches of cement-stabilized gravelly soil. The base course thickness of 4.0 inches would also have been required due to the minimum thickness of stabilized base.

b. Example 2. Assume a conventional flexible pavement has been designed which requires 2 inches of AC surface, 4 inches of crushed stone base, and 6 inches of subbase. It is desired to construct an all-bituminous pavement (ABC). The equivalency factor from table 8-1 for a base course is 1.15 and for a subbase is 2.30. The thickness of AC required to replace the base is 4 inches ÷ 1.15 = 3.5 inches, and the thickness of AC required to replace the subbase is 6 inches ÷ 2.30 = 2.6 inches. Therefore, the total thickness of the ABC pavement is 2 + 3.5 + 2.6 or 8.1 inches, which would be rounded to 8.0 inches.

8-8. Shoulders and Similar Areas.

These areas are provided only for the purpose of minimizing damage to vehicles which use them accidentally or in emergencies; therefore, they are not considered normal vehicular traffic areas. Normally, only shoulders for class A roads will be paved. Others will be surfaced with soils selected for their stability in wet weather and will be compacted as required. Dust and erosion control will be provided by means of vegetative cover, anchored mulch, coarse-graded aggregate, or liquid palliatives (TM 5-830-3/AFM 88-17, Chap 3). Shoulders will not block base-course drainage, particularly where frost

conditions are a factor. Where paving of shoulders is deemed necessary, the shoulders will be designed as a class F road or street.

8-9. Bituminous Sidewalks.

Permanent bituminous sidewalks will consist of a 4-inch-thick base with a 1-inch-thick bituminous surfacing. Material used locally in base construction for roads will normally be suitable as sidewalk base material. Bases may also be constructed of soils stabilized or modified in place with portland cement, lime, bituminous materials, or other acceptable stabilizers. In frost and permafrost areas, bases of sidewalks should be nonfrost-susceptible. The bituminous surfacing may consist of hot- or cold-mix bituminous concrete, sand-asphalt or sand-tar mixes, or sheet asphalt; in locations where the surface texture is not of prime importance, bituminous surface treatments may be used. Temporary walks or walks that are seldom used will be constructed of stable or stabilized soils or rock screenings containing granular and colloidal materials combined in the proportions necessary to ensure maximum density and stability under varied weather conditions, including frost action. Where necessary, the life of these walks may be prolonged by the application of bituminous surface treatments or by the addition of suitable stabilizing agents. The use of soil sterilants may be considered to prevent vegetation growth through bituminous sidewalks.

8-10. Bituminous Driveways.

Base course materials in residence driveway areas will be compacted to not less than 100 percent, and the top 6 inches of the subgrade to not less than 90 percent (95 percent for cohesionless sands and gravels) of the maximum density from ASTM D 1557. Minimum base course thicknesses for residence driveways are as follows:

| Subgrade CBR | Base course minimum thickness inches |
|---------------------|--------------------------------------|
| Greater than 7..... | 4 |
| 5 to 7..... | 6 |
| Less than 5..... | 8 |

The minimum paving requirements for residence driveways are a multiple bituminous surface treatment for base course CBR values less than 80 and a single-bituminous surface treatment for CBR values of 80 or above.

TM 5-822-5/AFM 88-7, Chap. 1

8-11. Curbs and Gutters.

Curbs and gutters will be provided with a foundation at least 4 inches thick of material of 50-CBR minimum. The material will be nonfrost-susceptible when required and will be compacted to the same requirements as the base or subbase course at the same elevation. The foundation for curbs and

gutters will not block the drainage of base course (TM 5-822-2/AFM 88-7, Chap 5).

8-12. Flexible Overlay Design.

For the design of flexible pavement overlays, see chapter 14 of this manual.

CHAPTER 9

RIGID PAVEMENT DESIGN

9-1. Soil Classification and Tests. All soils should be classified according to the Unified Soil Classification System (USGS) as given in ASTM D 2487. There have been instances in construction specifications where the use of such terms as "loam," "gumbo," "mud," and "muck" have resulted in misunderstandings. These terms are not specific and are subject to different interpretations throughout the United States. Such terms should not be used. Sufficient investigations should be performed at the proposed site to facilitate the description of all soils that will be used or removed during construction in accordance with ASTM D 2487; any additional descriptive information considered pertinent should also be included. If Atterberg limits are a required part of the description, as indicated by the classification tests, the test procedures and limits should be referenced in the construction specifications.

9-2. Compaction.

a. General. Compaction improves the stability of the subgrade soils and provides a more uniform foundation for the pavement. ASTM D 1557 soil compaction test conducted at several moisture contents is used to determine the compaction characteristics of the subgrade soils. The range of maximum densities normally obtained in the compaction test on various soil types is listed in TM 5-825-2. This test method should not be used if the soil contains particles that are easily broken under the blow of the tamper unless the field method of compaction will produce a similar degradation. Certain types of soil may require the use of a laboratory compaction control test other than the above-mentioned compaction test. The unit weight of some types of sands and gravels obtained using the compaction method above may be lower than the unit weight that can be obtained by field compaction; hence, the method may not be applicable. In those cases where a higher laboratory density is desired, compaction tests are usually made under some variation of the ASTM D 1557 method, such as vibration or tamping (alone or in combination) with a type hammer or compaction effort different from that used in the test.

b. Requirements. For all subgrade soil types, the subgrade under the pavement slab or base course must be compacted to a minimum depth of 6 inches. If the densities of the natural subgrade materials are equal to or greater than 90 percent of the maximum

density from ASTM D 1557, no rolling is necessary other than that required to provide a smooth surface. Compaction requirements for cohesive soils ($LL > 25$; $PI > 5$) will be 90 percent of maximum density for the top 6 inches of cuts and the full depth of fills. Compaction requirements for cohesionless soils ($LL < 25$; $PI < 5$) will be 95 percent for the top 6 inches of cuts and the full depth of fills. Compaction of the top 6 inches of cuts may require the subgrade to be scarified and dried or moistened as necessary and recompact to the desired density.

c. Special soils. Although compaction increases the stability and strength of most soils, some soil types show a marked decrease in stability when scarified, worked, and rolled. Also, expansive soils shrink excessively during dry periods and expand excessively when allowed to absorb moisture. When soils of these types are encountered, special treatment will usually be required. For nominally expansive soils, water content, compaction effort, and overburden should be determined to control swell. For highly expansive soils, replacement to depth of moisture equilibrium, raising grade, lime stabilization, prewetting, or other acceptable means of controlling swell should be considered (see TM 5-818-7 for guidance).

9-3. Treatment of Unsuitable Soils. Soils not suitable for subgrade use (as specified in TM 5-825-2/AFM 88-6, Chap 2, and MIL-STD-619) should be removed and replaced or covered with soils which are suitable. The depth to which such adverse soils should be removed or covered depends on the soil type, drainage conditions, and depth of freezing temperature penetration and should be determined by the engineer on the basis of judgment and previous experience, with due consideration of the traffic to be served and the costs involved. Where freezing temperatures penetrate a frost-susceptible subgrade, design procedures outlined in chapter 17 herein, or TM 5-852-3 as applicable, should be followed. In some instances, unsuitable or adverse soils may be improved economically by stabilization with such materials as cement, flyash, lime, or certain chemical additives, whereby the characteristics of the composite material become suitable for subgrade purposes. Criteria for soil stabilization are in TM 5-822-4. However, subgrade stabilization should not be attempted unless the costs reflect corresponding savings in base-course,

pavement, or drainage facilities construction.

9-4. Determination of Modulus of Subgrade Reaction. For the design of rigid pavements in those areas where no previous experience regarding pavement performance is available, the modulus of subgrade reaction *k* to be used for design purposes is determined by the field plate-bearing test. This test procedure and the method for evaluating its results are given in MIL-STD-621A. Where performance data from existing rigid pavements are available, adequate values for *k* can usually be determined on the basis of consideration of soil type, drainage conditions, and frost conditions that pre-

vail at the proposed site. Table 9-1 presents typical values of *k* for various soil types and moisture conditions. These values should be considered as a guide only, and their use in lieu of the field plate-bearing test, although not recommended, is left to the discretion of the engineer. Where a base course is used under the pavement, the *k* value on top of the base is used to determine the pavement thickness. The plate-bearing test may be run on top of the base, or figure 9-1 may be used to determine the modulus of soil reaction on top of the base. It is good practice to confirm adequacy of the *k* on top of the base from figure 9-1 by running a field plate-load test.

*Table 9-1. Modulus of Soil Reaction**

| Type of material | Moisture content percentage | | | | | | |
|---|-----------------------------|--------|---------|----------|----------|----------|---------------------|
| | 1 to 4 | 5 to 8 | 9 to 12 | 13 to 16 | 17 to 20 | 21 to 24 | 25 to 28 Over 28 |
| Silts and clays, LL greater than 50 (OH, CH, MH)..... | | 175 | 150 | 125 | 100 | 75 | 50 |
| Silts and clays LL less than 50 (OL, CL, ML)..... | | 200 | 175 | 150 | 125 | 100 | 75 |
| Silty and clayey sands (SM and SC)..... | 300 | 250 | 225 | 200 | 150 | | |
| Sand and gravelly sands (SW and SP)..... | 350 | 300 | 250 | | | | |
| Silty and clayey gravels (GM and GC)..... | 400 | 350 | 300 | 250 | | | |
| Gravel and sandy gravels (GW and GP)..... | 500 | 450 | | | | | |

Notes:

1. Values of *k* shown are typical for materials having dry densities equal to 90 to 95 percent of the maximum. For materials having dry densities less than 90 percent of the maximum, values should be reduced by 50 pounds per cubic inch (pci), except that a *k* of 25 pci will be the minimum used for design.

2. Values shown may be increased slightly if density is greater than 95 percent of the maximum, except that a *k* of 500 pci will be the maximum used for design.

3. Frost area *k* values are given in chapter 10 of this manual.

*Typical values of *k* in pci for rigid pavement design.

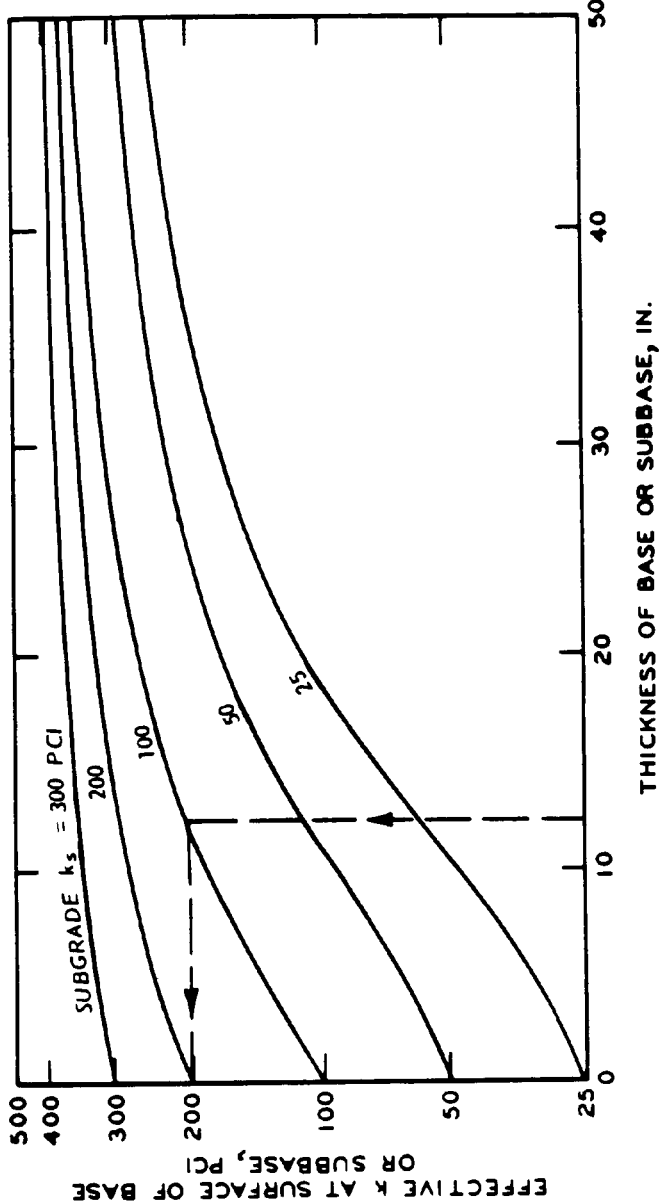

Figure 9-1. Effect of Base-Course Thickness on Modulus of Soil Reaction.

CHAPTER 10

RIGID PAVEMENT BASE COURSES

10-1. General Requirements.

Base courses may be required under rigid pavements for replacing soft, highly compressible or expansive soils and for providing the following.

- a.* Additional structural strength.
- b.* More uniform bearing surface for the pavement.
- c.* Protection for the subgrade against detrimental frost action.
- d.* Drainage.
- e.* Suitable surface for the operation of construction equipment, especially slipform pavers.

Use of base courses under a rigid pavement to provide structural benefit should be based on economy of construction. The first cost is usually less for an increase in thickness than for providing a thick base course. However, thick base courses have often resulted in lower maintenance costs since the thick base course provides stronger foundation and therefore less slab movement. A minimum base-course thickness of 4 inches is required over subgrades that are classified as OH, CH, CL, MH, ML, and OL to provide protection against pumping. In certain cases of adverse moisture conditions (high water table or poor drainage), SM and SC soils also may require base courses to prevent pumping. The designer is cautioned against the use of fine-grained material for leveling courses or choking open-graded base courses since this may create a pumping condition. Positive drainage should be provided for all base courses to ensure water is not trapped directly beneath the pavement since saturation of these layers will cause the pumping condition that the base course is intended to prevent. The base course material and drains must meet the drainage criteria listed in TM 5-820-2/AFM 88-5, Chap. 2.

10-2. Materials.

If conditions indicate that a base course is desirable under a rigid pavement, a thorough investigation should be made to determine the source, quantity, and characteristics of the available materials. A study should also be made to determine the most economical thickness of material for a base course that will meet the requirements. The base course may consist of natural, processed, or stabilized materials. The material selected should be the one that best accomplishes the intended purpose of the base course. In general, the base-course material should be a well-graded, high-stability material. In this connection all base courses to be placed beneath concrete pavements for military roads and streets should conform to the following requirements:

- a.* Percent passing No.10 sieve; Not more than 85.
- b.* Percent passing No.200 sieve: Not more than 15.
- c.* Plasticity index: Not higher than 6.

Where local experience indicates their desirability, other control limitations such as limited abrasion loss may be imposed to ensure a uniform high-quality base course.

10-3. Compaction.

Where base courses are used under rigid pavements, the base-course material should be compacted to a minimum of 95 percent of the maximum density. The engineer is cautioned that it is difficult to compact thin base courses to high densities when they are placed on yielding subgrades.

10-4. Frost Requirements.

In areas where subgrade soils are subjected to seasonal frost action detrimental to the performance of pavements, the requirements for base-course thickness and gradation will follow the criteria in chapter 18 of this manual.

CHAPTER 11

CONCRETE PAVEMENT

11-1. Mix Proportioning and Control.

Proportioning of the concrete mix and control of the concrete for pavement construction will be in accordance with TM 5-822-7. Normally, a design flexural strength at 28-day age will be used for the pavement thickness determination. Should it be necessary to use the pavements at an earlier age, consideration should be given to the use of a design flexural strength at the earlier age or to the use of high early strength cement, whichever is more economical. Flyash gains strength more slowly than cement, so that if used it may be desirable to select a strength value at a period other than 28 days if time permits.

11-2. Testing.

The flexural strength of the concrete and lean concrete base will be determined in accordance with ASTM C 78. The standard test specimen will be a 6- by 6-inch section long enough to permit testing over a span of 18 inches. The standard beam will be

used for concrete with the maximum size aggregate up to 2 inches. When aggregate larger than the 2-inch nominal size is used in the concrete, the cross-sectional dimensions of the beam will be at least three times the nominal maximum size of the aggregate, and the length will be increased to at least 2 inches more than three times the depth.

11-3. Special Conditions.

Mix proportion or pavement thickness may have to be adjusted due to results of concrete tests. If the tests show a strength gain less than predicted or a retrogression in strength, then the pavement would have to be thicker. If the concrete strength was higher than predicted, then the thickness may be reduced. Rather than modifying the thickness required as a result of tests on the concrete, the mix proportioning could be changed to increase or decrease the concrete strength, thereby not changing the thickness.

CHAPTER 12

PLAIN CONCRETE PAVEMENT DESIGN

12-1. General.

Rigid pavements for roads, streets, and open storage areas at military installations will be plain (nonreinforced) concrete except for those conditions listed in chapter 13 or unless otherwise approved by HQUSACE (CEMP-ET), or the appropriate Air Force Major Command.

12-2. Roller-Compacted Concrete Pavements.

Roller-compacted concrete pavements (RCCP) are plain concrete pavements constructed using a zero-slump portland cement concrete mixture that is placed with an AC paving machine and compacted with vibratory and rubber-tired rollers. The design of RCCP is presented in chapter 17.

12-3. Design Procedure.

For convenience in determining design requirements, the entire range of vehicle loadings and traffic intensities anticipated during the design life of pavements for the various classifications of military roads and streets has been expressed as an equivalent number of repetitions of an 18,000-pound single-axle loading. To further simplify the design procedure, the range of equivalent repetitions of the basic loading thus determined has been designated by a numerical scale defined as the pavement design index. This index extends from 1 through 10 with an increase in numerical value indicative of an increase in pavement design requirements. Values for the design index are determined using the procedure in chapter 3. Once the design index has been determined the required thickness of plain concrete pavement is then ob-

tained from the design chart presented in figure 12-1 for roads and streets. Figure 12-2 is used to determine the thickness of parking and storage areas except that the thickness of roller-compacted concrete parking and storage areas will be designed using figure 12-1. These design charts are graphical representations of the interrelation of flexural strength, modulus of subgrade reaction k , pavement thickness, and repetitions (design index) of the basic 18,000-pound single-axle loading. These design charts are based on the theoretical analyses of Westergaard (*New Formulas for Stresses in Concrete Pavements of Airfields*, ASCE Transactions), supplemented by empirical modifications determined from accelerated traffic tests and observations of pavement behavior under actual service conditions. The design charts are entered using the 28-day flexural strength of the concrete. A horizontal projection is then made to the right to the design value for k . A vertical projection is then made to the appropriate design-index line. A second horizontal projection to the right is then made to intersect the scale of pavement thickness. The dashed line shown on curves is an example of the correct use of the curves. When the thickness from the design curve indicates a fractional value, it will be rounded up to the next 1/2-inch thickness. All plain concrete pavements will be uniform in cross-sectional thickness. Thickened edges are not normally required since the design is for free edge stresses. The minimum thickness of plain concrete for any military road, street, or open storage area will be 6 inches.

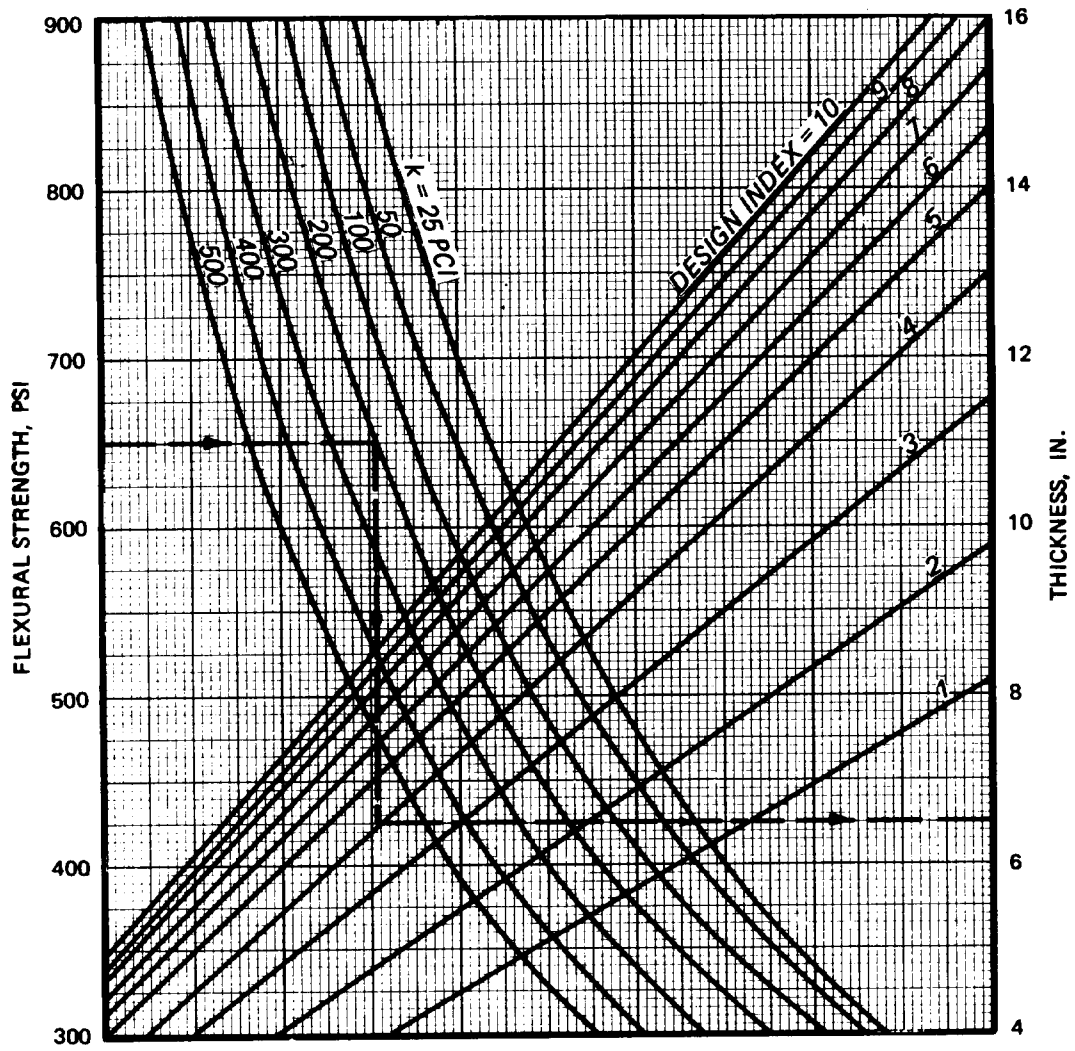

Figure 12-1. Design Curves for Plain Concrete Roads and Streets, and RCCP.

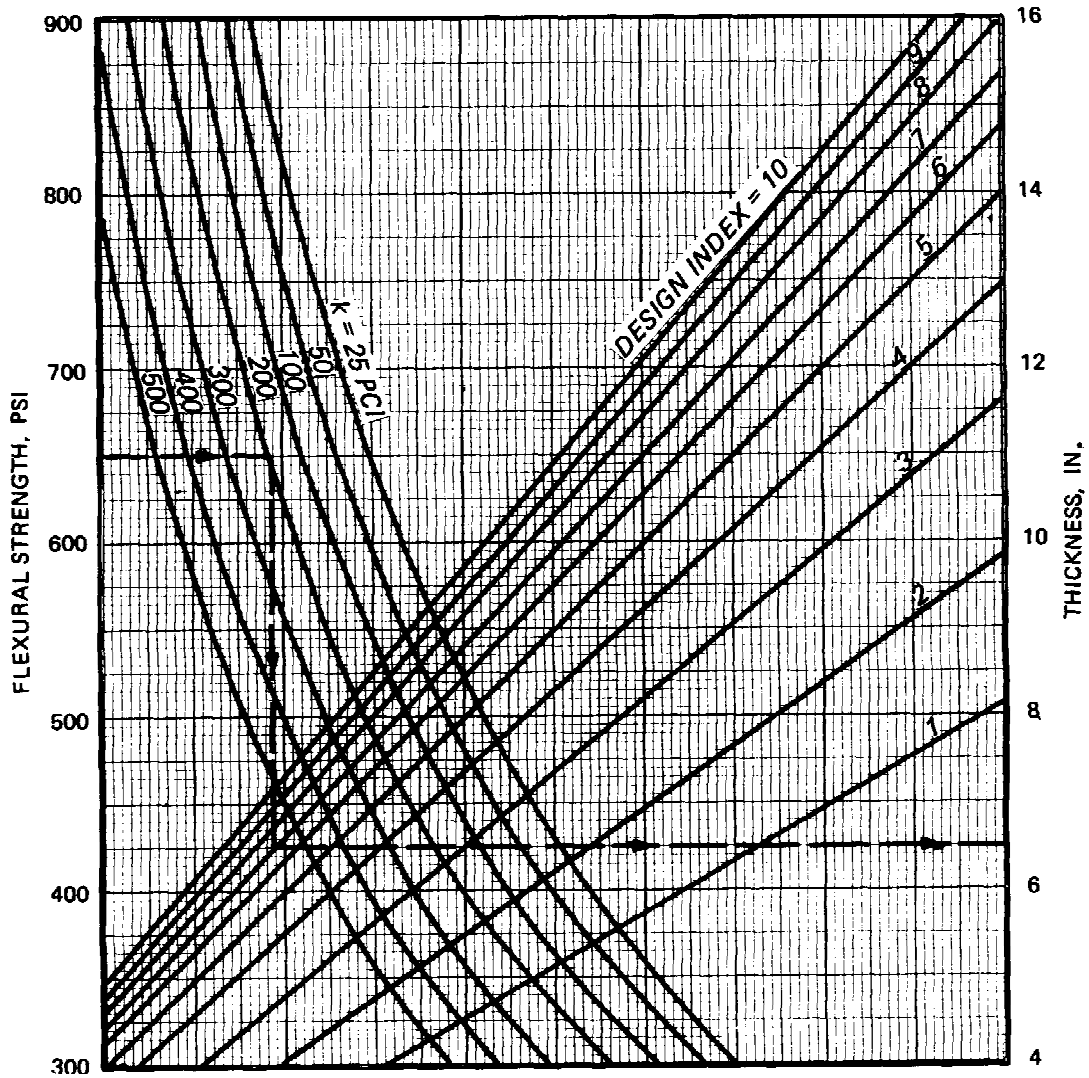

Figure 12-2. Design Curve for Plain Concrete Parking and Open Storage Areas.

12-4. Design Procedure for Stabilized Foundations.

The thickness requirements for a plain concrete pavement on a modified soil foundation will be designed as if the layer is unbound using the k value measured on top of the modified soil layer. For stabilized soil layers, the treated layer will be considered to be a low-strength base pavement and the thickness determined using the following modified partially bonded overlay pavement design equation:

$$h_o = 1.4 \sqrt{h_d^{1.4} - (0.0063^3 \sqrt{E_f \cdot h_s})^{1.4}} \quad (e_1 | 12-1)$$

where

- h_o = thickness of plain concrete pavement overlay required over the stabilized layer, inches
- h_d = thickness of plain concrete pavement from design chart (fig. 12-1) based on k value of unbound material, inches
- E_f = flexural modulus of elasticity of the stabilized soil. The modulus value for bituminous stabilized soils will be determined according to the procedures in appendix B. The modulus value for lime and cement stabilized soils will be determined using the results of CRD-C 21 and the equations in appendix B
- h_s = thickness of stabilized layer, inches

TM 5-822-5/AFM 88-7, Chap. 1

For additional information on stabilization and mix proportioning see TM 5-822-4 and TM 5-818-1.

12-5. Design Examples.

As an example of the application of the design procedures given for nonstabilized foundations, design a plain concrete pavement for a road in a rural area on rolling terrain to carry the following traffic:

| | |
|------------------------------|-------------------------|
| Average daily volume..... | 3,500 vehicles per lane |
| Trucks, 2 axle..... | 150 per lane per day |
| Trucks, 3 or more axles..... | 50 per lane per day |

Based on the criteria in TM 5-822-2/AFM 88-7, Chap 5, this traffic would be evaluated as requiring a class C road. It would be designed for category IV traffic and a design index of 5. Assuming a 28-day flexural strength for the concrete of 675 psi, and a k value of 100 pounds per cubic inch (pci), the required pavement thickness as indicated by figure 12-1 is approximately 7.3 inches. This thickness value would be rounded off to 7.5 inches for design. To illustrate the design procedure when traffic includes tracked vehicles, assume that in addition to the pneumatic-tired traffic used in the previous example, the designer must provide for an average of 60 tanks per lane per day and that the gross weight of each tank is 50,000 pounds. The 50,000-pounds gross weight would be classified as category V traffic (according to chapter 3) since it exceeds the maximum of 40,000 pounds permitted for tracked vehicles in category IV traffic. Inasmuch as the tank traffic exceeds 40 per day, the rigid pavement design index would be based on the next higher traffic volume given in table 3-1, which is 100 per day. Thus, the design index for a class C street would be 6. Assuming the same 28-day flexural strength and k value as in the previous example, the required pavement thickness is approximately 7.75 inches (fig 12-1) and would require a design thickness of 8.0 inches. To illustrate the procedure for combining tracked vehicles with pneumatic-tired vehicles, design a rigid pavement on rolling terrain for the following traffic:

| | |
|---------------------------------------|-----------------------|
| Average daily volume..... | 750 vehicles per lane |
| Trucks, 2 axle..... | 100 per lane per day |
| Trucks, 3 or more axles..... | 40 per lane per day |
| Track-laying vehicles, 50,000 pounds. | 50 per lane per day |
| Track-laying vehicles, 80,000 pounds. | 20 per lane per day |

According to TM 5-822-2/AFM 88-7, Chap 5, the traffic on rolling terrain would be evaluated as requiring a class D road or class E street. From

chapter 3, the 50-kilopounds (kip) tracked vehicles would be classified as category V traffic. For a fire-quench of 50 of these vehicles per lane per day, the pavement design index would be 6. The 80-kip tracked vehicles are classified as category VI traffic. For a frequency of 20 of these vehicles per lane per day, the pavement design index would be 7. Thus, it can be seen that the 80-kip tracked vehicle traffic governs as it requires the highest design index. Assuming the same 28-day flexural strength and k value as in the previous design examples, the required pavement thickness is 8.1 inches (fig 12-1) which would be rounded to 8.5 inches for design. For this same example, if the plain concrete pavement is to be placed on 6 inches of cement stabilized soil having an E~ value of 500,000 psi, then the thickness of plain concrete re- quire would be as follows using equation 12-1.

$$h_o = 1.4 \sqrt{h_d^{1.4} - (0.0063 \sqrt{E_f} h_o)^{1.4}}$$

$$h_o = 1.4 \sqrt{(8.1)^{1.4} - [0.0063 \sqrt{500,000} (6)]^{1.4}}$$

$$h_o = 6.6 \text{ inches (round to 7.0 inches for design)}$$

Design examples for rigid pavement for frost conditions are discussed in chapter 18.

12-6. Concrete Sidewalks.

Portland cement concrete walks may be provided at installations where pedestrian traffic justifies this type of construction. Normally, the design thickness for walks will be 4 inches. Where it is necessary and desirable to continue the walk across driveways and private entrances, provided for vehicle crossings, the thickness of the walk should be increased to provide sufficient strength to support the vehicular loads to which such portions of the walks will be subjected. Concrete walks should be grooved transversely into rectangular areas with the longest dimension no greater than 1.25 times the shorter dimension to create planes of weakness for control of contraction cracking. The depth of such grooves should be a minimum of one-fourth the thickness of the slab and need not be sealed. Expansion joints consisting of approved preformed bituminous filler or wood approximately 1/2 inch thick should be installed to surround or to separate all structures or features which project through or against the sidewalk slab. Expansion joints of a similar type should be installed at regularly spaced intervals transversely across the sidewalk slab. The spacing for such joints should be not less than 30 feet nor more than 50 feet. A base is only recommended at locations where past experience has shown that sub-

grade soils exhibit unacceptable swell and frost heave potential. These soils can result in safety problems with differential joint elevations.

12-7. Concrete Driveways.

Under normal conditions, rigid pavement for residential driveways will be either 6-inch plain concrete or 5-inch reinforced concrete with 0.10 percent of reinforcement steel. In plain concrete pavement design, slab lengths will not exceed 15 feet with 12 feet recommended. For reinforced pavement, slab lengths up to 30 feet may be used. The residential driveways will be 6 inches thick and reinforced with a minimum of 0.05 percent of reinforcement steel when the following adverse conditions prevail: when concrete flexural strength is below 630 psi and the subgrade modulus k is below

50 pci, and when frost penetrates a frost-susceptible material underlying the rigid pavement on small jobs in frost areas. Where the flexural strength or subgrade modulus is unknown, the design will be 6 inches of concrete with a 6-inch base course. Contraction or construction joints provided in a driveway will be designed and sealed in accordance with chapter 15 or 16. Expansion joints consisting of approved preformed bituminous filler or wood should be installed to surround or separate all structures which project through or against the driveway slabs.

12-8. Curbs, Gutters, and Shoulders.

For a discussion of the design of curbs, gutters, and shoulders, see paragraphs 8-8 and 8-11 of this manual.

CHAPTER 13

REINFORCED CONCRETE PAVEMENTS

13-1. Application

Under certain conditions, concrete pavement slabs may be reinforced with welded wire fabric or formed bar mats arranged in a square or rectangular grid. The advantages of using steel reinforcement include a reduction in the required slab thickness, greater spacing between joints, and reduced differential settlement due to nonuniform support or frost heave.

a. Subgrade conditions. Reinforcement may reduce the damage resulting from cracked slabs. Cracking may occur in rigid pavements founded on subgrades where differential vertical movement is a definite potential. An example is a foundation with definite or borderline frost susceptibility that cannot feasibly be made to conform to conventional frost design requirements.

b. Economic considerations. In general, reinforced concrete pavements will not be economically

competitive with plain concrete pavements of equal load-carrying capacity, even though a reduction in pavement thickness is possible. Alternate bids, however, should be invited if reasonable doubt exists on this point.

c. Plain concrete pavements. In otherwise plain concrete pavements, steel reinforcement should be used for the following conditions:

(1) *Odd-shaped slabs.* Odd-shaped slabs should be reinforced in two directions normal to each other using a minimum of 0.05 percent of steel in both directions. The entire area of the slab should be reinforced. An odd-shaped slab is considered to be one in which the longer dimension exceeds the shorter dimension by more than 25 percent or a slab which essentially is neither square nor rectangular. Figure 13-1 includes examples of reinforcement required in odd-shaped slabs.

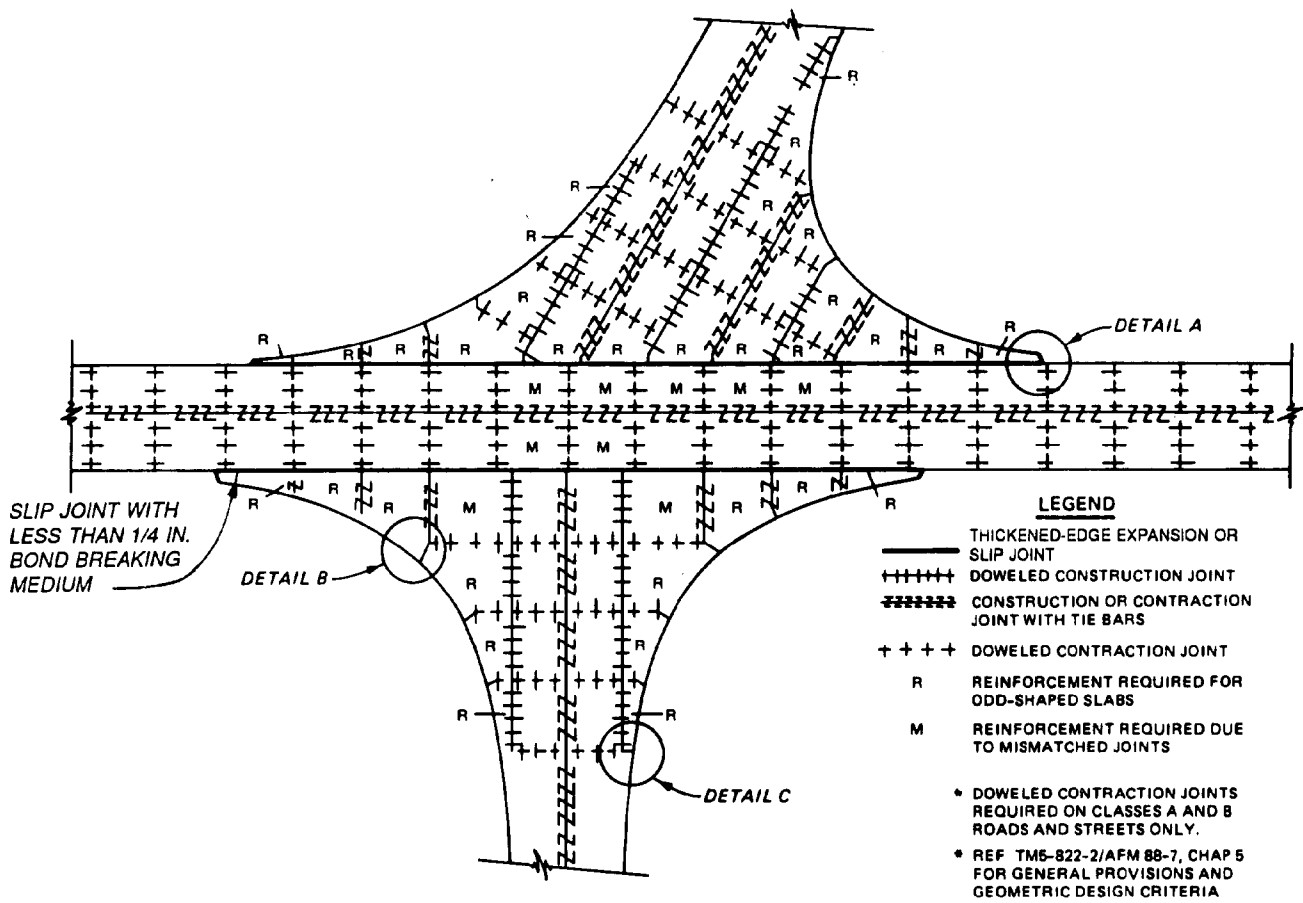

Figure 13-1. Typical Layout of Joints at Intersection. (Sheet 1 of 2)

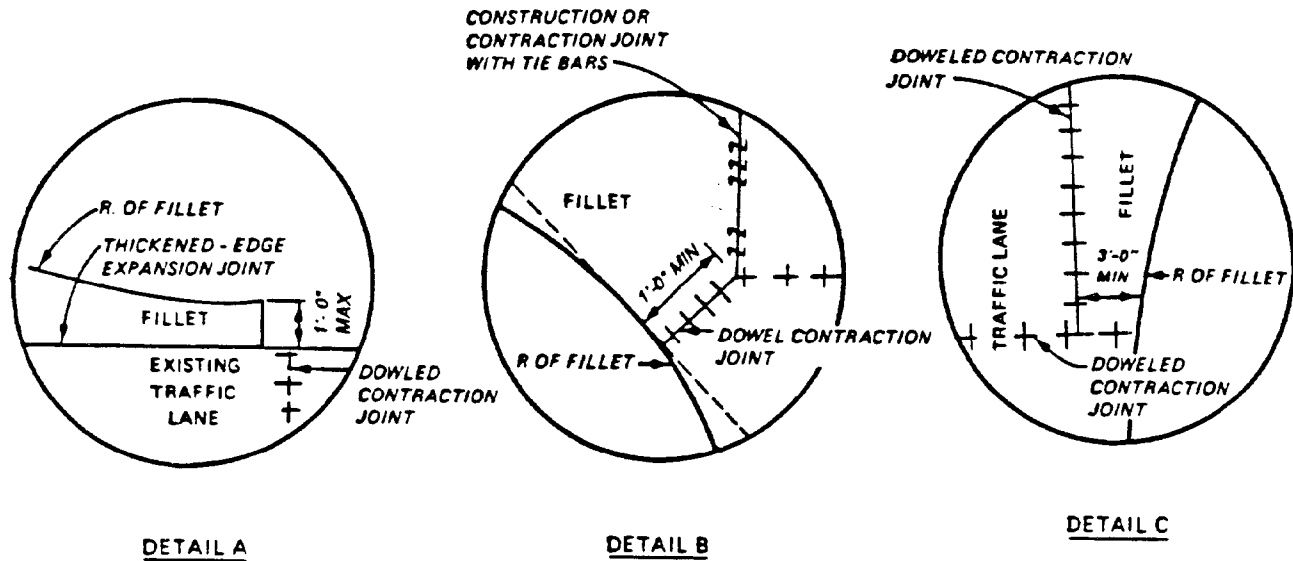

Figure 13-1. Typical Layout of Joints at Intersection. (Sheet 2 of 2)

(2) *Mismatched joints.* A partial reinforcement or slab is required where the joint patterns of abutting pavements or adjacent paving lanes do not match, unless the pavements are positively separated by an expansion joint or slip-type joint having a bond less than 1/4-inch bond-breaking medium. The pavement slab directly opposite the mismatched joint should be reinforced with a minimum of 0.05 percent of steel in directions normal to each other for a distance of 3 feet back from the juncture and for the full width or length of the slab in 8 directions normal to the mismatched joint. Mismatched joints normally will occur at intersections of pavements or between pavement and fillet areas as shown in figure 13-1.

d. *Other uses.* Reinforced concrete pavements may be considered for reasons other than those described above provided that a report containing a justification of the need for reinforcement is prepared and submitted for approval to HQUSACE (CEMP-ET) or the appropriate Air Force Major Command.

13-2. Design Procedure.

a. *Thickness design on unbound base or subbase.* The design procedure for reinforced concrete pavements uses the principle of allowing a reduction in the required thickness of plain concrete pavement due to the presence of the steel reinforcing. The design procedure has been developed empirically from a limited number of prototype test pavements subjected to accelerated

traffic testing. Although some cracking will occur in the pavement under the design traffic loadings, the steel reinforcing will hold the cracks tightly closed. The reinforcing will prevent spalling or faulting at the cracks and provide a serviceable pavement during the anticipated design life. Essentially, the design method consists of determining the percentage of steel required, the thickness of the reinforced concrete pavement, and the minimum allowable length of the slabs. Figure 13-2 presents a graphic solution for the design of reinforced concrete pavements. Since the thickness of a reinforced concrete pavement is a function of the percentage of steel reinforcing, the designer may determine either the required percentage of steel for a predetermined thickness of pavement or the required thickness of pavement for a predetermined percentage of steel. In either case, it is necessary first to determine the required thickness of plain concrete pavement by the method outlined previously in chapter 12. The plain concrete pavement thickness h_d (to the nearest 0.1 inch) is used to enter the nomograph in figure 13-2. A straight line is then drawn from the value of h_d to the value selected for either the reinforced concrete pavement thickness h_r or the percentage of reinforcing steel S . It should be noted that the S value indicated by figure 13-2 is the percentage to be used in the longitudinal direction only. For normal designs, the percentage of steel used in the transverse direction will be one-half of that to be used in the longitudinal direction. In fillets, the percent steel will be the same in both directions.

Once the h_r and S values have been determined, the maximum allowable slab length L is obtained from the intersection of the straight line and the scale or

L . Difficulties may be encountered in sealing joints between very long slabs because of large volumetric changes caused by temperature changes.

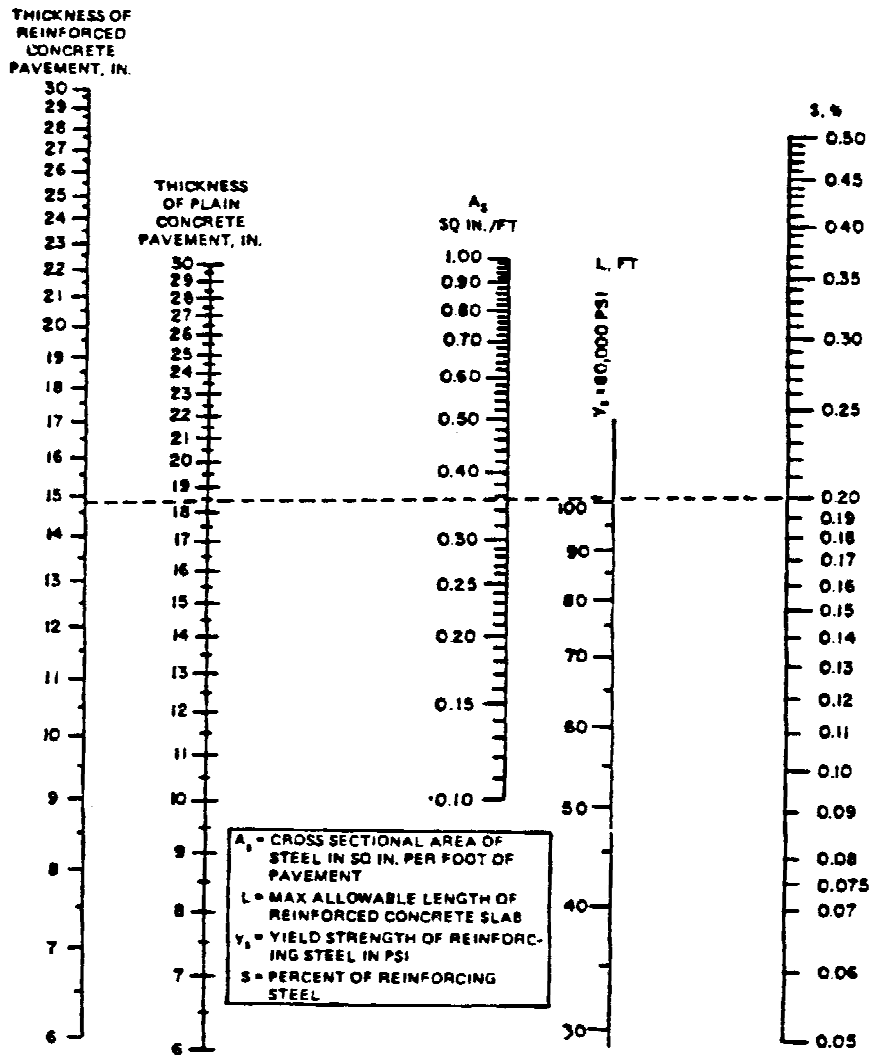

Figure 13-2. Reinforced Rigid Pavement Design

b. Thickness design on stabilized base or subgrade. To determine the thickness requirements for reinforced concrete pavement on a stabilized foundation, it is first necessary to determine the thickness of plain concrete pavement required over

the stabilized layer using procedures set forth in chapter 12. This thickness of plain concrete is then used with figure 13-2 to design the reinforced concrete pavement in the same manner discussed above for nonstabilized foundations.

13-3. Limitations.

The design criteria for reinforced concrete pavement for military roads and streets are subject to the following limitations.

a. No reduction in the required thickness of plain concrete pavement should be allowed for percentages of longitudinal steel less than 0.05 percent.

b. No further reduction in the required thickness of plain concrete pavement should be allowed over that indicated in figure 13-2 for 0.5 percent longitudinal steel, regardless of the percentage of steel used.

c. The maximum length *L* of reinforced concrete pavement slabs should not exceed 75 feet regardless of the percentage of longitudinal steel, yield strength of the steel, or thickness of the pavement. When long slabs are used, special consideration must be given to joint design and sealant requirements.

d. The minimum thickness of reinforced concrete pavements should be 6 inches, except that the minimum thickness for driveways will be 5 inches and the minimum thickness for reinforced overlays over rigid pavements will be 4 inches.

13-4. Reinforcing Steel.

a. Type of reinforcing steel. The reinforcing steel may be either deformed bars or welded wire fabric. Deformed bars should conform to the requirements of ASTM A 615, A 616, or A 617. In general, grade 60 deformed bars should be specified, but other grades may be used if warranted. Fabricated steel bar mats should conform to ASTM A 184. Cold drawn wire for fabric reinforcement should conform to the requirements of ASTM A 82, and welded steel wire fabric to ASTM A 185. The use of epoxy coated steel may be considered in areas where corrosion of the steel may be a problem.

b. Placement of reinforcing steel. The reinforcing steel will be placed at a depth of $\frac{1}{4}h_d + 1$ inch from the surface of the reinforced slab. This will place the steel above the neutral axis of the slab and will allow clearance for dowel bars. The wire or bar sizes and spacing should be selected to give, as nearly as possible, the required percentage of steel per foot of pavement width or length. In no case should the percent steel used be less than that required by figure 13-2. Two layers of wire fabric or bar mat, one placed directly on top of the other, may be used to obtain the required percent of steel; however, this should only be done when it is impracticable to provide the required steel in one layer. If two layers of steel are used, the layers must be fastened together (either wired or clipped) to

prevent excessive separation during concrete placement. When the reinforcement is installed and concrete is to be placed through the mat or fabric, the minimum clear spacing between bars or wires will be $1\frac{1}{2}$ times the maximum size of aggregate. If the strike-off method is used to place the reinforcement (layer of concrete placed and struck off at the desired depth, the reinforcement placed on the plastic concrete, and the remaining concrete placed on top of the reinforcement), the minimum spacing of wires or bars will not be less than the maximum size of aggregate. Maximum bar or wire spacing or slab thickness shall not exceed 12 inches. The bar mat or wire fabric will be securely anchored to prevent forward creep of the steel mats during concrete placement and finishing operations. The reinforcement shall be fabricated and placed in such a manner that the spacing between the longitudinal wire or bar and the longitudinal joint, or between the transverse wire or bar and the transverse joint, will not exceed 3 inches or one-half of the wire or bar spacing in the fabric or mat. The wires or bars will be lapped as follows.

(1) Deformed steel bars will be overlapped for a distance of at least 24 bar diameters measured from the tip of one bar to the tip of the other bar. The lapped bars will be wired or otherwise securely fastened to prevent separation during concrete placement.

(2) Wire fabric will be overlapped for a distance equal to at least one spacing of the wire in the fabric or 32 wire diameters, whichever is greater. The length of lap is measured from the tip of one wire to the tip of the other wire normal to the lap. The wires in the lap will be wired or otherwise securely fastened to prevent separation during concrete placement.

13-5. Design Examples.

As an example, let it be required to design a reinforced concrete pavement for the same set of conditions used in the initial design example given previously in paragraph 12-4. Using the value of h_d of 7.9 inches, the percentage of longitudinal reinforcing steel *S* required to reduce the pavement thickness to 7 inches is obtained from figure 13-2 as 0.10 percent. Similarly, the percentage of longitudinal reinforcing steel required to reduce the pavement thickness to 6 inches is 0.30 percent. The percentage of transverse reinforcing steel would be either 0.05 for a design thickness of 7 inches or 0.15 for a design thickness of 6 inches. The choice of which percentage of steel reinforcement to use should be based on economic considerations as well as on foundation and climatic conditions peculiar to

the project area. If the yield strength of the steel is assumed to be 60,000 psi, the maximum allowable spacing of the transverse contraction joints would be 49 feet for 0.10 percent longitudinal steel, and 97 feet would be indicated as the maximum spacing for 0.30 percent longitudinal steel. In the latter case, the maximum permissible spacing of 75 feet would be used.

13-6. Design Details.

Typical details for the design and construction of reinforced concrete pavements for military roads and streets are shown in figures 13-3, 13-4, 13-5, and 13-6.

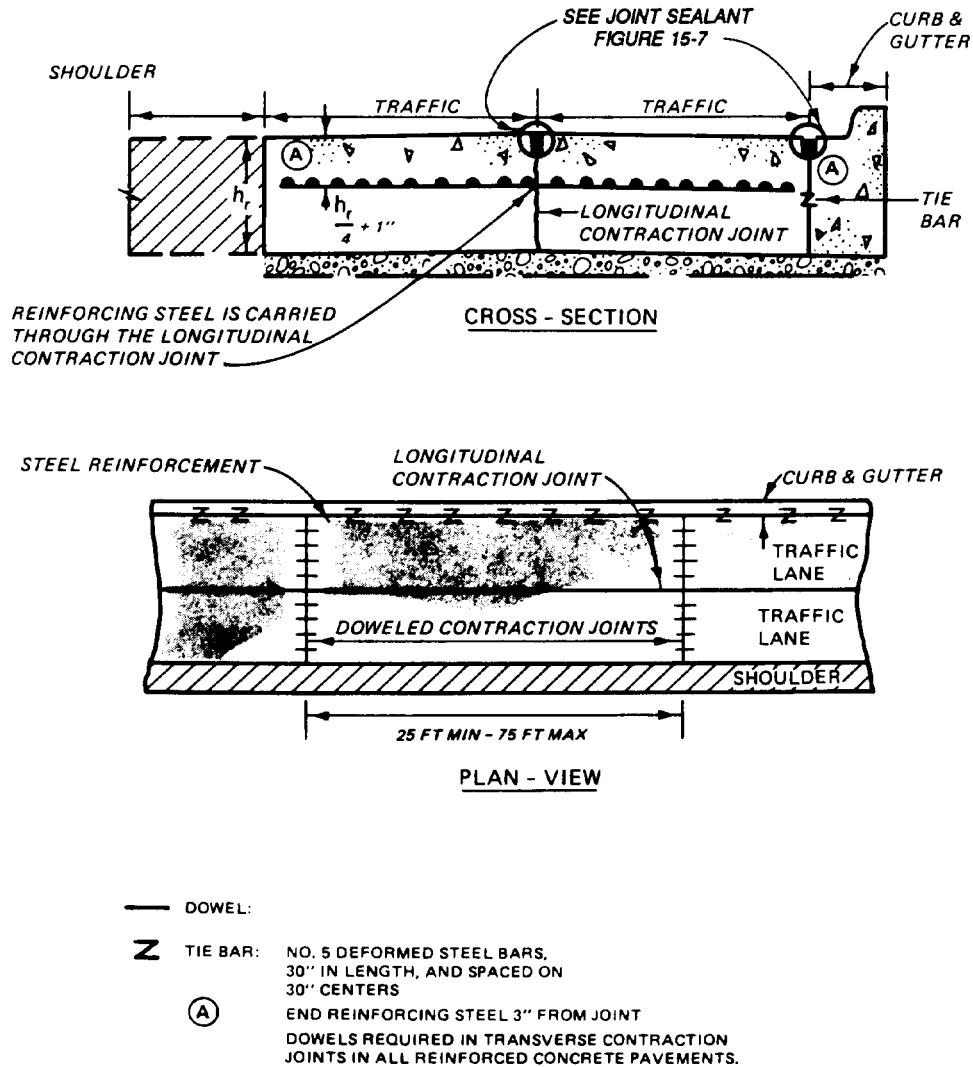

Figure 13-3. Design Details of Reinforced Rigid Pavement with Two Traffic Lanes. (Sheet 1 of 2)

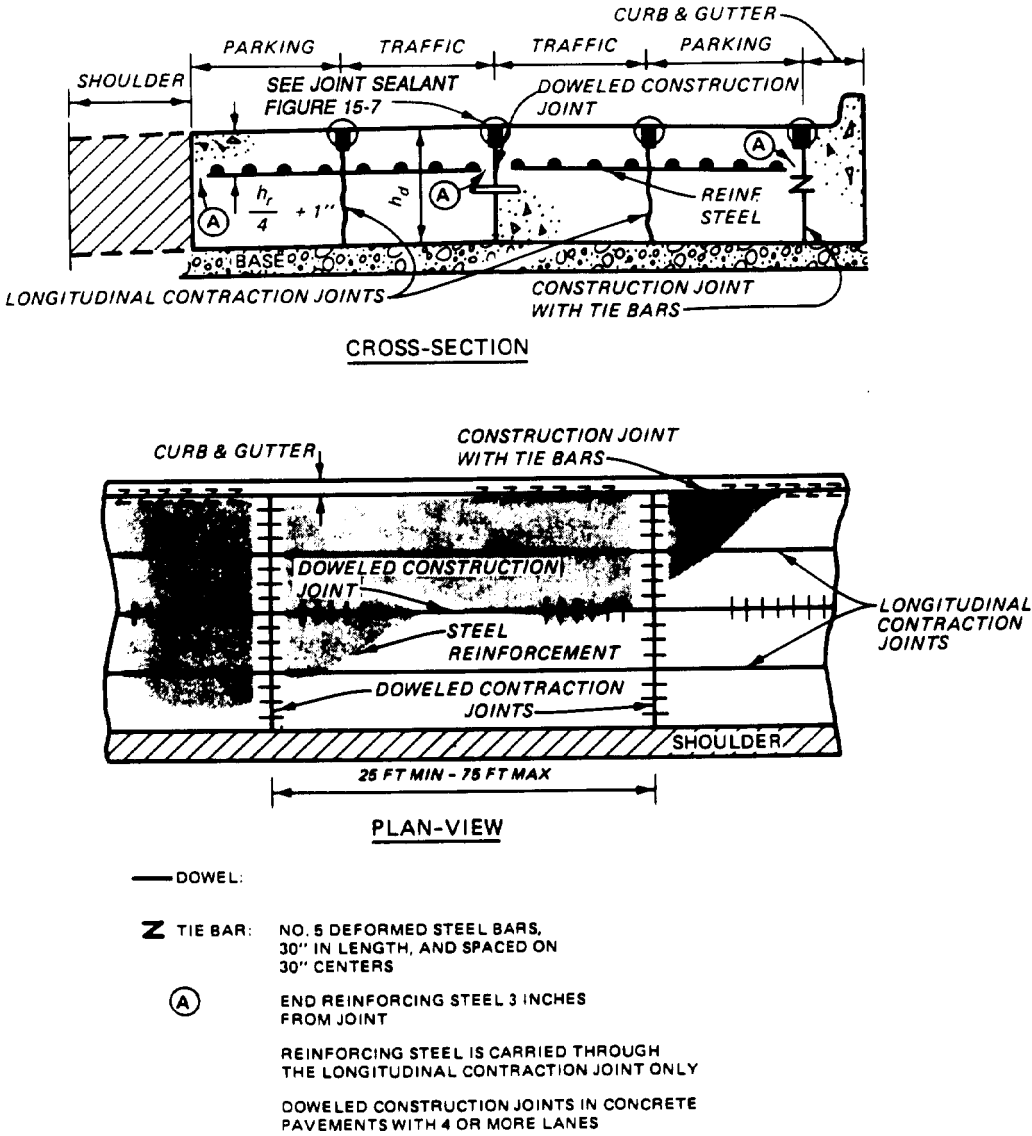

Figure 13-3. Design Details of Reinforced Rigid Pavement with Two Traffic Lanes. (Sheet 2 of 2)

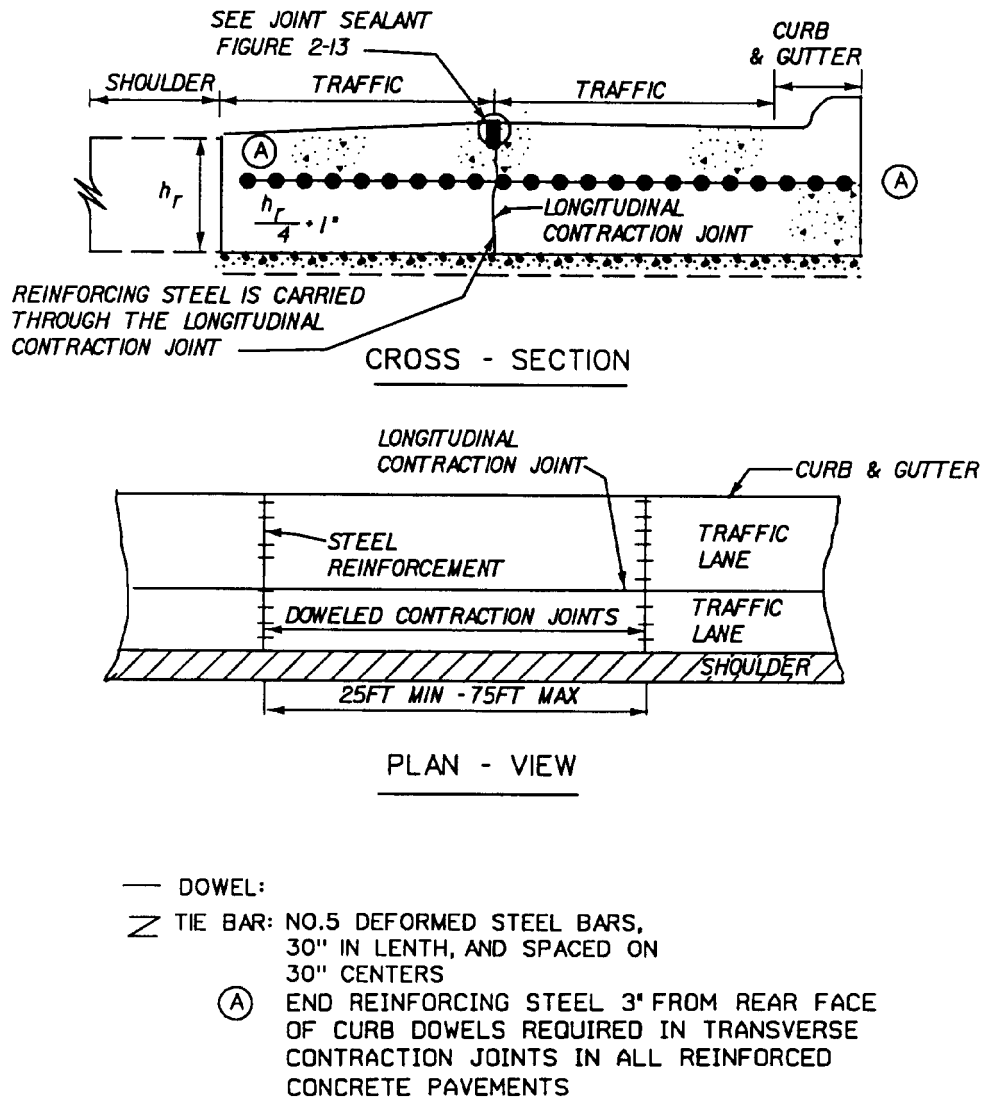

Figure 13-4. Design Details of Reinforced Rigid Pavement with Traffic and Parking Lanes.

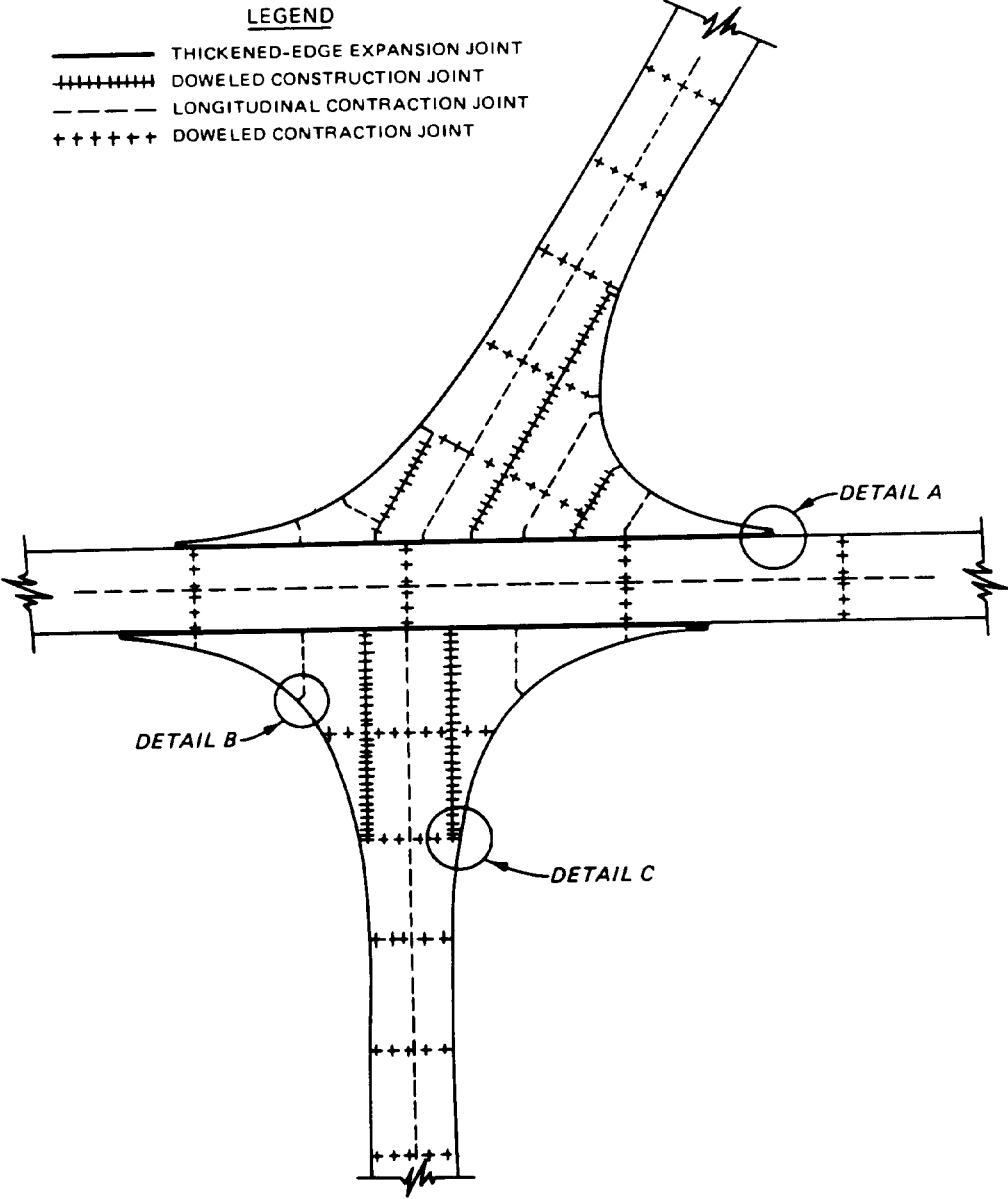

Figure 13-5. Design Details of Reinforced Rigid Pavement with Integral Curb. (Sheet 1 of 2)

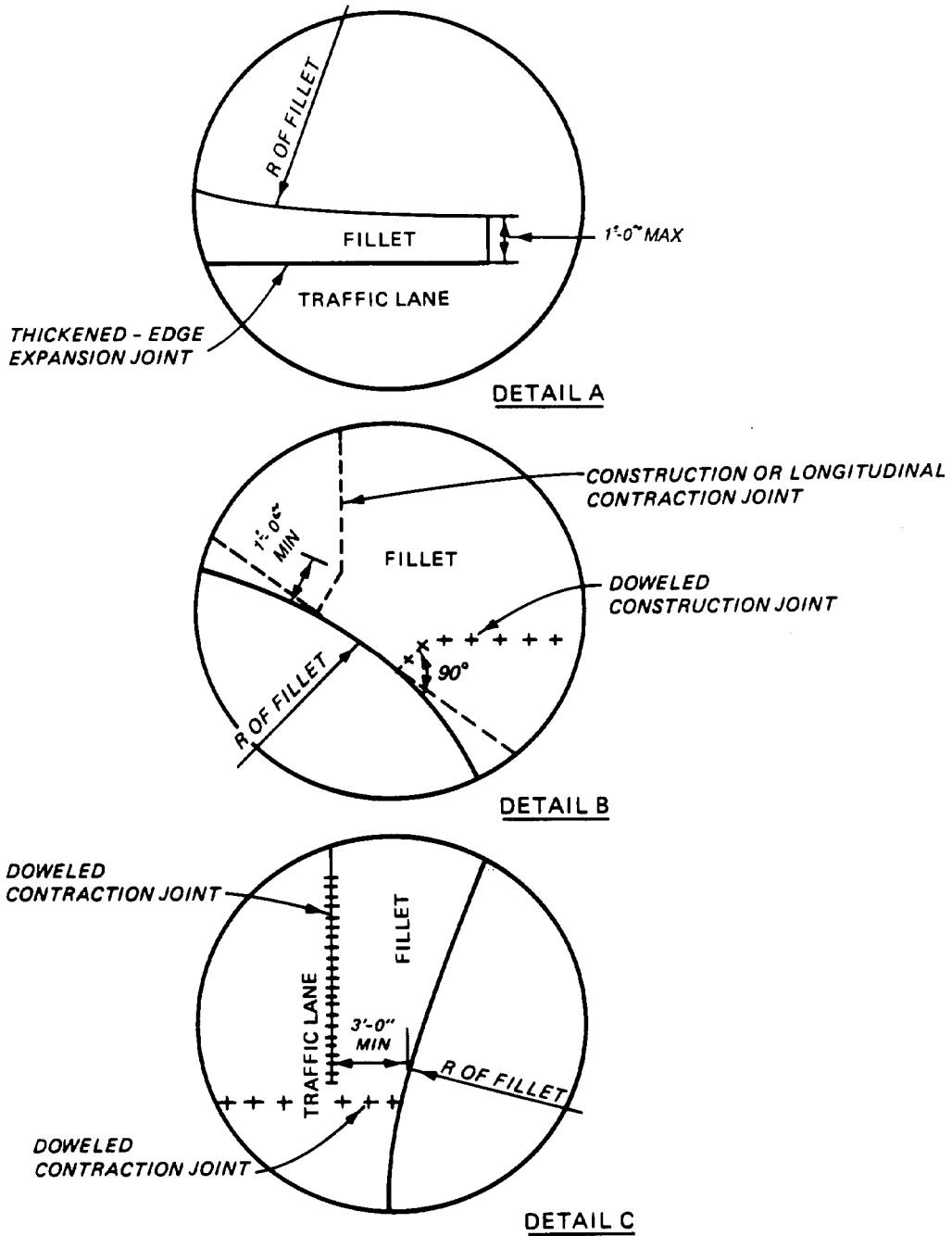

Figure 13-5. Design Details of Reinforced Rigid Pavement with Integral Curb. (Sheet 2 of 2)

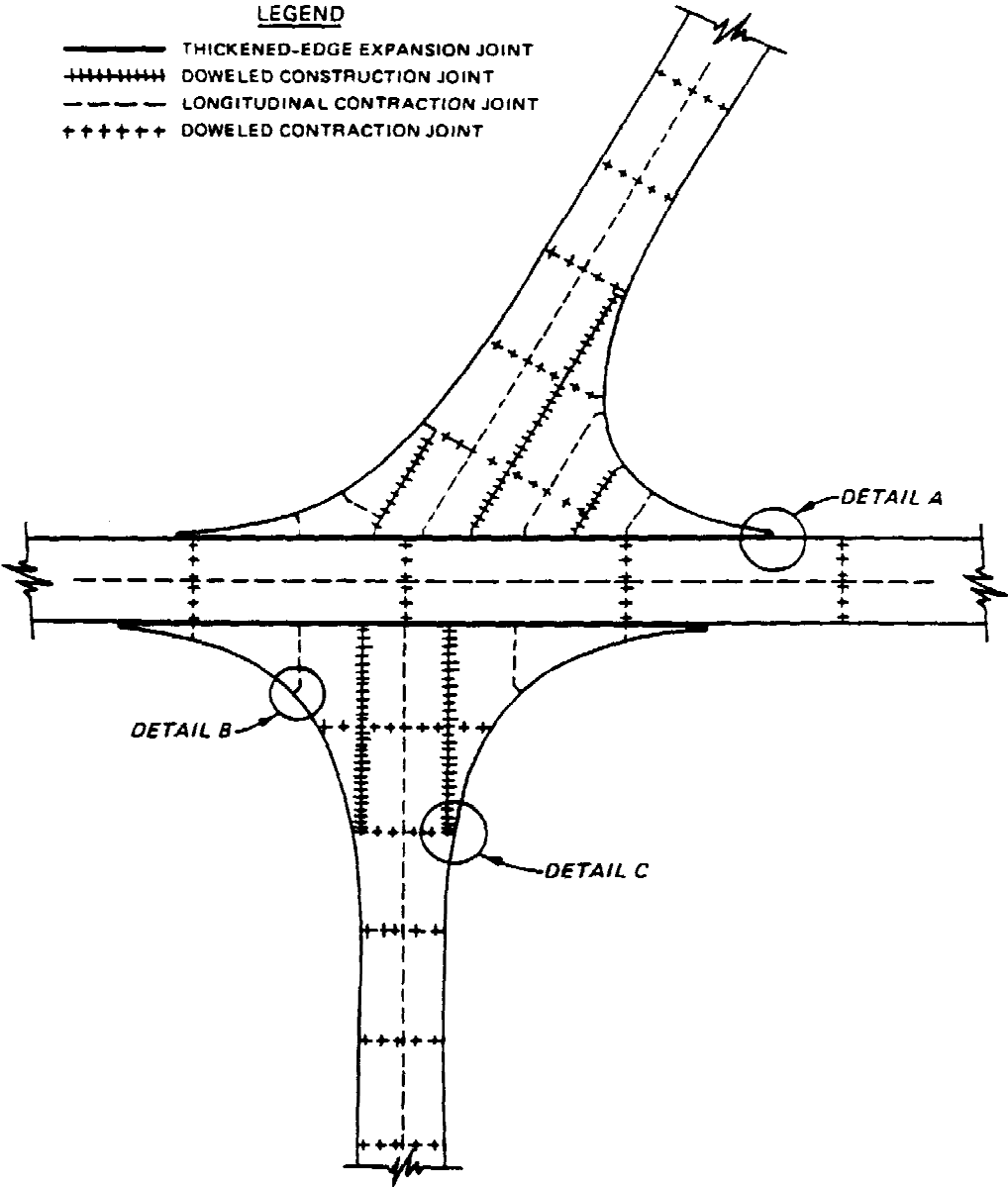

Figure 13-6. Typical Layout of Joints at the Intersection of Reinforced Rigid Pavement. (Sheet 1 of 2)

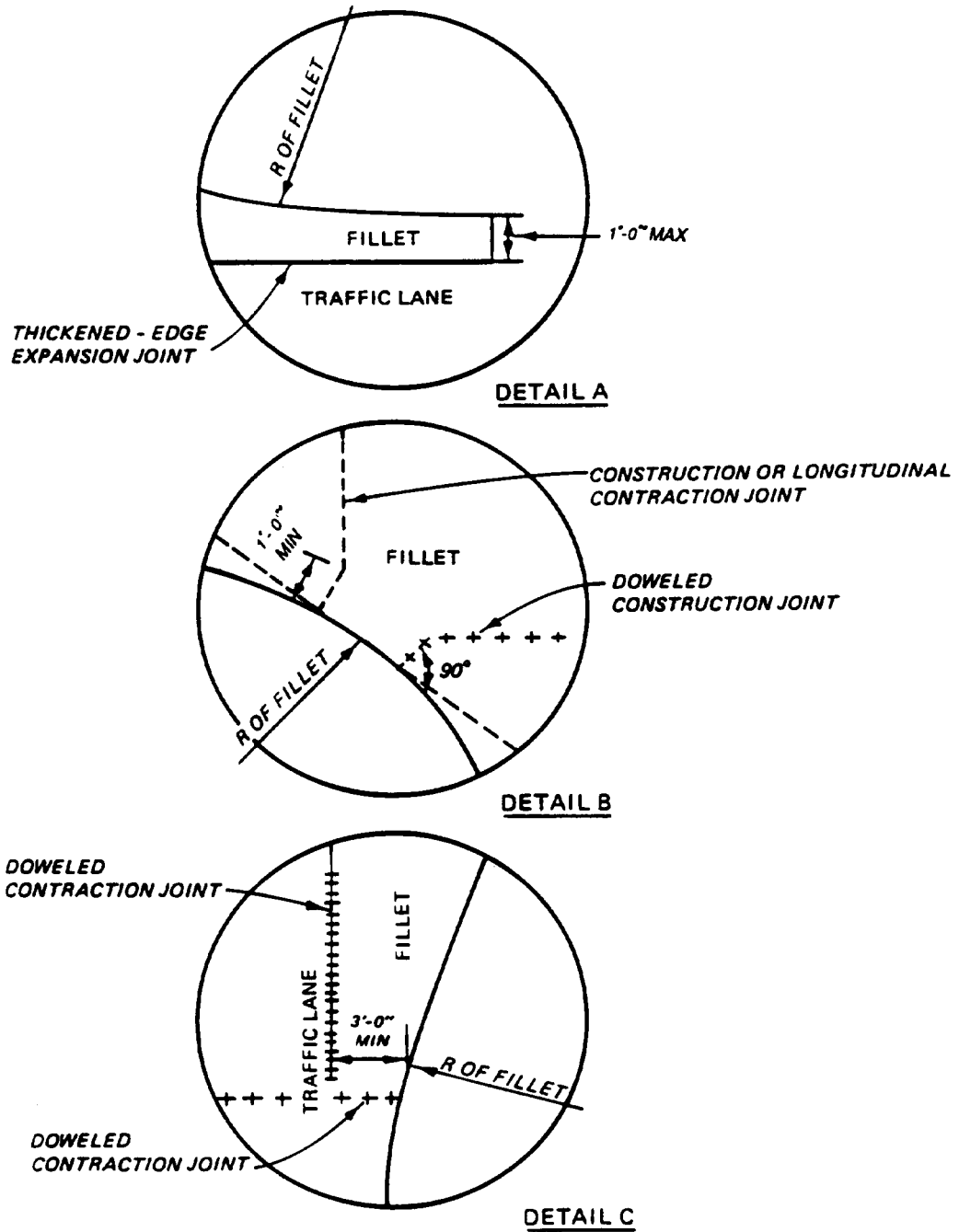

Figure 13-6. Typical Layout of Joints at the Intersection of Reinforced Rigid Pavement. (Sheet 2 of 2)

CHAPTER 14

PAVEMENT OVERLAYS

14-1. General.

Normally, overlays of existing pavements are used to increase the load-carrying capacity of an existing pavement or to correct a defective surface condition on the existing pavement. Of these reasons, the first requires a structural design procedure for determining the thickness of overlay; whereas the second requires only a thickness of overlay sufficient to correct the surface condition, and no increase in load-carrying capacity is considered. The design method for overlays included in this chapter determines the thickness required to increase load-carrying capacity. These methods have been developed from a series of full-scale accelerated traffic tests on various types of overlays and are, therefore, empirical. These methods determine the required thickness of overlay that, when placed on the existing pavement, will be equivalent in performance to the required design thickness of a new pavement placed on subgrade.

14-2. Definitions and Symbols for Overlay Pavement Design.

The following terms and symbols apply to the design of overlay pavements.

- a. Rigid base pavement.* An existing rigid pavement is one on which an overlay is to be placed.
- b. Flexible base pavement.* Existing pavement to be overlaid is composed of bituminous concrete, base, and subbase courses.
- c. Composite pavement.* Existing pavement to be overlaid with rigid pavement is composed of an all-bituminous or flexible overlay on a rigid base pavement.
- d. Overlay pavement* A pavement constructed on an existing base pavement to increase load-carrying capacity or correct a surface defect.
- e. Rigid overlay.* A rigid pavement used to strengthen an existing flexible or rigid pavement.
- f. Flexible overlay.* A flexible pavement (either all-bituminous or bituminous with base course) used to strengthen an existing rigid or flexible pavement.

14-3. Preparation of Existing Pavement.

Exploration and tests of the existing pavement should be made to locate all areas of distress in the existing pavement and to determine the cause of the distress. Areas showing extensive and progressive cracking, rutting, and foundation failures should be

repaired prior to the overlay. Such repair is especially needed in areas where excessive pumping, bleeding of water at joints or cracks, excessive settlement in foundation, subgrade rutting, surface rutting, and slides have occurred. If testing of the existing pavement indicates the presence of voids beneath a rigid pavement, they should be filled by grouting prior to the overlay. The properties of the existing pavement and foundation such as the modulus of subgrade reaction, CBR, thickness, condition index, and flexural strength should be determined. The exact properties to be determined will depend upon the type of overlay to be used. The surface of the existing pavement should be conditioned for the various types of overlays as follows.

a. Rigid overlay. Overlay thickness criteria are presented for three conditions of bond between the rigid overlay and existing rigid pavement: fully bonded, partially bonded, and nonbonded. The fully bonded condition is obtained when the concrete is cast directly on concrete and special efforts are made to obtain bond. The partially bonded condition is obtained when the concrete is cast directly on concrete with no special efforts to achieve or destroy bond. The nonbonded condition is obtained when the bond is prevented by an intervening layer of material. When a fully bonded or partially bonded rigid overlay is to be used, the existing rigid pavement will be cleaned of all foreign matter (such as oil and paint), spalled concrete, extruded joint seal, bituminous patches, or anything else that would act as a bond-breaker between the overlay and existing rigid pavement. In addition, for the fully bonded overlay, the surface of the existing pavement must be prepared according to the recommendation in TM 5-822-7. A sand-cement grout or an epoxy grout is applied to the cleaned surface just prior to placement of the concrete overlay. When a nonbonded rigid overlay is being used, the existing rigid pavement will be cleaned of all loose particles and covered with a leveling or bond-breaking course of bituminous concrete, sand-asphalt, heavy building paper, polyethylene, or other similar stable material. The bond-breaking medium generally should not exceed a thickness of about 1 inch except in the case of leveling courses where greater thicknesses may be necessary. When a rigid overlay is being applied to an existing flexible pavement, the surface of the existing pavement will

TM 5-822-5/AFM 88-7, Chap. 1

be cleaned of loose materials, and any potholing or unevenness exceeding about 1 inch will be repaired by cold planing or localized patching or the application of a leveling course using bituminous concrete, sand-asphalt, or a similar material.

b. Flexible overlay. When a flexible overlay is used, no special treatment of the surface of the existing rigid pavement will be required, other than the removal of loose material. When the flexible overlay is all-bituminous concrete, the surface of the existing rigid pavement will be cleaned of all foreign matter, spalled concrete, fat spots in bituminous patches, and extruded soft or spongy joint seal material. Joints or cracks less than 1 inch wide in the existing rigid pavement will be filled with joint sealant. Joints or cracks that are 1 inch or greater in width will be cleaned and filled with an acceptable bituminous mixture (such as sand asphalt) which is compatible with the overlay. Leveling courses of bituminous concrete will be used to bring the existing rigid pavement to the proper grade when required. Prior to placing the all-bituminous concrete, a tack coat will be applied to the surface of the existing pavement.

14-4. Condition of Existing Rigid Pavement.

a. General. The support that the existing rigid pavement will provide to an overlay is a function of its structural condition just prior to the overlay. In the overlay design equations, the structural condition of the existing rigid pavement is assessed by a condition factor *C*. The value of *C* should be selected based upon a condition survey (TM 5-826-6/AFR 93-5) of the existing rigid pavement. Interpolation of *C* values between those shown below may be used if it is considered necessary to define more accurately the existing structural condition.

b. Plain concrete overlay. The following values of *C* are assigned for the following conditions of plain and reinforced concrete pavements.

(1) Condition of Existing Plain Concrete Pavement:

- C* = 1.00 — Pavements are in good condition with little or no structural cracking due to load.
- C* = 0.75 — Pavements exhibit initial cracking due to load but no progressive cracking or faulting of joints or cracks.
- C* = 0.35 — Pavements exhibit progressive cracking due to load accompanied by spalling, raveling, or faulting of cracks and joints.

(2) Condition of Existing Reinforced Concrete Pavement:

- C* = 1.00 — Pavements are in good condition with little or no short-spaced transverse (1-to 2-foot) cracks, no longitudinal cracking, and little spalling or raveling along cracks.
- C* = 0.75 — Pavements exhibit short-spaced transverse cracking but little or no interconnecting longitudinal cracking due to load and only moderate spalling or raveling along cracks.
- C* = 0.35—Pavements exhibit severe short-spaced transverse cracking and interconnecting longitudinal cracking due to load, severe spalling along cracks, and initial punchout-type failures.

c. Flexible Overlay. The following values of *C* are assigned for the following conditions of plain and reinforced concrete pavement.

(1) Condition of Existing Plain Concrete Pavements:

- C* = 1.00 — Pavements are in good condition with some cracking due to load but little or no progressive-type cracking.
- C* = 0.75 — Pavement exhibit progressive cracking due to load and spalling, raveling, and minor faulting at joints and cracks.
- C* = 0.50—Pavements exhibit multiple cracking along with raveling, spalling, and faulting at joints and cracks

(2) Condition of Existing Reinforced Concrete Pavement.

- C* = 1.00 — Pavements are in good condition but exhibit some closely spaced load-induced transverse cracking, initial interconnecting longitudinal cracks, and moderate spalling or raveling of joints and cracks.
- C* = 0.75 — Pavements in trafficked areas exhibit numerous closely spaced load-induced transverse and longitudinal cracks, rather severe spalling or raveling, or initial evidence of punchout failures.

14-5. Rigid Overlay of Existing Rigid Pavement.

a. General. There are three basic equations for the design of rigid overlays which depend upon the

degree of bond that develops between the overlay and existing pavement: fully bonded, partially bonded, and nonbonded. The fully bonded overlay equation is used when special care is taken to provide bond between the overlay and the existing pavement. The partially bonded equation will be used when the rigid overlay is to be placed directly on the existing pavement and no special care is taken to provide bond. A bond-breaking medium and the nonbonded equation will be used when a plain concrete overlay is used to overlay an existing reinforced concrete pavement or an existing plain concrete pavement that has a condition factor $C \leq 0.35$. They will also be used when matching joints in a plain concrete overlay with those in the existing plain concrete pavement causes undue construction difficulties or results in odd-shaped slabs.

b. Plain concrete overlay.

(1) *Thickness determination.* The required thickness h_o of plain concrete overlay will be determined from the following applicable equations:

Fully bonded

$$h_o = h_d - h_E \quad (\text{eq 14-1})$$

Partially bonded

$$h_o = 1.4 \sqrt{h \frac{1.4}{d} - C \left(\frac{h_d}{h_e} \times h_E \right)^{1.4}} \quad (\text{eq 14-2})$$

Nonbonded

$$h_o = \sqrt{h \frac{2}{d} - C \left(\frac{h_d}{h_e} \times h_E \right)^2} \quad (\text{eq 14-3})$$

where h_d is the design thicknesses of plain concrete pavement determined from figures 12-1 or 12-2 using the design flexural strength of the overlay and h_e is the design thickness of plain concrete pavement using the measured flexural strength of the existing rigid pavement; the modulus of soil reaction k of the existing rigid pavement foundation; and the design index needed for overlay design. The use of fully bonded overlay is limited to existing pavements having a condition index of 1.0 and to overlay thickness of 2.0 to 5.0 inches. The fully bonded overlay is used primarily to correct a surface problem such as scaling rather than as a structural upgrade. The factor h_E represents the thickness of the existing plain concrete pavement or the equivalent thickness of plain concrete pavement having the same load-carrying capacity as the existing pavement. If the existing pavement is reinforced concrete, h_E is determined from figure 18-2 using the percent reinforcing steel S and

design thickness h_e . The minimum thickness of plain concrete overlay will be 2 inches for a fully bonded overlay and 6 inches for a partially bonded or nonbonded overlay. The required thickness of overlay must be rounded to the nearest full or 1/2-inch increment. When the indicated thickness falls midway between 1 and 1/2-inch, the thickness will be rounded up. See paragraph 14-11 for overlay design example.

(2) *Jointing.* For all partially bonded and fully bonded plain concrete overlays, joints will be provided in the overlay to coincide with all joints in the existing rigid pavement. It is not necessary for joints in the overlay to be of the same type as joints in the existing pavement. When it is impractical to match the joints in the overlay to joints in the existing rigid pavement, either a bond-breaking medium will be used and the overlay designed as a nonbonded overlay or the overlay will be reinforced over the mismatched joints. Should the mismatch of joints become severe, a reinforced concrete overlay design should be considered as an economic alternative to the use of a nonbonded plain concrete overlay. For nonbonded plain concrete overlays, the design and spacing of transverse contraction joints will be in accordance with requirements for plain concrete pavements. For both partially bonded and nonbonded plain concrete overlays, the longitudinal construction joints will be doweled using the dowel size and spacing discussed in chapter 15. Dowels and load-transfer devices will not be used in fully bonded overlays. Joint sealing for plain concrete overlays will conform to the requirements for plain concrete pavements.

c. Reinforced concrete overlay. A reinforced concrete overlay may be used to strengthen either an existing plain concrete or reinforced concrete pavement. Generally, the overlay will be designed as a partially bonded overlay. The nonbonded overlay design will be used only when a leveling course is required over the existing pavement. The reinforcement steel for reinforced concrete overlays will be designed and placed in accordance with reinforced concrete pavements.

(1) *Thickness determination.* The required thickness of reinforced concrete overlay will be determined using figure 13-2 after the thickness of plain concrete overlay has been determined from the appropriate overlay equation. Then, using the value for the thickness of plain concrete overlay, either the thickness of reinforced concrete overlay can be selected and the required percent steel determined or the percent steel can be selected and the thickness of reinforced concrete overlay determined

from figure 13-2. The minimum thickness of reinforced concrete overlay will be 4 inches.

(2) *Jointing.* Whenever possible, the longitudinal construction joints in the overlay should match the longitudinal joints in the existing pavement. All longitudinal joints will be doweled with dowel size and spacing designated in chapter 15 using the thickness of reinforced concrete overlay. It is not necessary for transverse joints in the overlay to match joints in the existing pavement; however, when practical, the joints should be matched. The maximum spacing of transverse contraction joints will be determined in accordance with equation 16-1, but it will not exceed 75 feet regardless of the thickness of the pavement or the percent steel used. Joint sealing for reinforced concrete pavements will conform to the requirements for plain concrete pavements.

14-6. Rigid Overlay of Existing Flexible or Composite Pavements.

a. Flexible pavements. A rigid overlay of an existing flexible pavement should be designed in the same manner as a rigid pavement on grade. A modulus of subgrade reaction k should be determined by a plate-bearing test made on the surface of the existing flexible pavement. If not practicable to determine k from a plate-bearing test, an approximate value may be determined using figure 9-1. Figure 9-1 yields an effective k value at the surface of the flexible pavement as a function of the subgrade k and thickness of base and sub-base above the subgrade. When using figure 9-1, the bituminous concrete is considered to be unbound base course material. Using this k value and the concrete flexural strength, the required thickness of plain concrete overlay is determined from figure 12-1 or 12-2. However, the following limitations should apply:

(1) In no case should a k value greater than 500 pci be used.

(2) The plate-bearing test to determine the k value should be performed on the flexible pavement at a time when the temperature of the bituminous concrete is of the same order as the ambient temperature of the hottest period of the year in the locality of the proposed construction.

b. Composite base pavements. Two conditions of composite pavement can be encountered when considering a rigid overlay. When the composite pavement is composed of a rigid base pavement with less than 4 inches of all-bituminous overlay, the required thickness of rigid overlay should be determined using the nonbonded overlay equation. If the composite pavement is composed of a rigid

base pavement with 4 inches or more of either all-bituminous or bituminous with base course overlay, the required thickness of overlay should be determined by paragraph 14-6a. The same limitations for maximum k value and temperature of pavement at the time of test should apply.

14-7. Flexible Overlay of Flexible Pavement.

Overlays are used for strengthening or rehabilitation of an existing pavement. Strengthening is required when heavier loads are introduced or when a pavement is no longer capable of supporting the loads for which it was designed. Rehabilitation may include sealing or resealing of cracks, patching, limited reconstruction prior to an overlay, restoration of the surface profile, improvement of skid resistance by a friction course, or improvement of the surface quality. When it has been determined that strengthening is required, the design of an overlay will be accomplished by initially designing a new pavement and comparing its thickness with the thickness of the existing pavement. The difference between these two pavements is the thickness of overlay required to satisfy design requirements. Overlays may be all-bituminous concrete or AC and base course. The flexible pavement after being overlaid shall meet all compaction requirements of a new pavement. Where the existing construction is complex, consisting of several layers, and especially where there are semirigid layers, such as soil cement, cement-stabilized soils, or badly cracked portland cement concrete, careful exercise of judgment will be necessary to evaluate the existing materials. Guidance for evaluating existing construction is given in TM 5-826-2/AFM 88-24, Chap 2.

14-8. Flexible Overlay of Rigid Base Pavement.

a. Design procedure. The design procedure presented determines the thickness of flexible overlay necessary to increase the load-carrying capacity of existing rigid pavement. This method is limited to the design of the two types of flexible overlay, the all-bituminous and the bituminous with base course. The selection of the type of flexible overlay to be used for a given condition is dependent only on the required thickness of the overlay. Normally, the bituminous with base course overlay should be used when the required thickness of overlay is sufficient to incorporate a minimum 4-inch compacted layer of high-quality base-course material plus the required thickness of bituminous concrete surface courses. For lesser thicknesses of flexible overlay, the all-bituminous overlay should be used. The method of design is referenced to the deficiency in

thickness of the existing rigid base pavement and assumes that a controlled degree of cracking will take place in the rigid base pavement during the design life of the pavement.

b. Thickness determination. Regardless of the type of nonrigid overlay, the required thickness t_o will be determined by

$$t_o = 3.0 (Fh_d - Ch_e) \quad (\text{eq 14-4})$$

where h_d is the design thickness of plain concrete pavement from figure 12-1 or 12-2 using the flexural strength R of the concrete in the existing rigid pavement, the modulus of soil reaction k of the existing pavement, and the appropriate design index. The factor h_e represents the thickness of plain concrete pavement equivalent in load-carrying ability to the thickness of existing rigid pavement. If the existing rigid pavement is plain concrete, then the equivalent thickness equals the existing thickness; however, if the existing rigid pavement is reinforced concrete, the equivalent thickness must be determined from figure 13-2. F is a factor, determined from figure 14-1, that projects the cracking expected to occur in the base pavement during the design life of the overlay. C is a coefficient from paragraph 14-4 based upon the structural condition of the existing rigid pavement. The computed thickness of overlay will be rounded to the nearest whole or $\frac{1}{2}$ inch. To reduce reflective cracking, the minimum thickness of all-bituminous

overlay used for strengthening purposes will be 4 inches. No limitation is placed on the minimum thickness of an all-bituminous overlay when used for maintenance or to improve pavement surface smoothness. In certain instances, the flexible overlay design equation will indicate thickness requirements less (sometimes negative values) than the minimum values. In such cases the minimum thickness requirement will be used. When strengthening existing rigid pavements that exhibit low flexural strength (less than 500 psi) or that are constructed on high-strength foundation (k exceeding 200 pci), it may be found that the flexible pavement design procedure in this manual indicates a lesser required overlay thickness than the overlay design formula. For these conditions, the overlay thickness will be determined by both methods, and the lesser thickness will be used for design. For the flexible pavement design procedure, the existing rigid pavement will be considered an equivalent thickness of high-quality crushed aggregate base (CBR=100), and the total pavement thickness determined based upon the subgrade CBR. Any existing base or subbase layers will be considered as corresponding layers in the flexible pavement. The thickness of required overlay will then be the difference between the required flexible pavement thickness and the combined thicknesses of existing rigid pavement and any base or subbase layers above the subgrade.

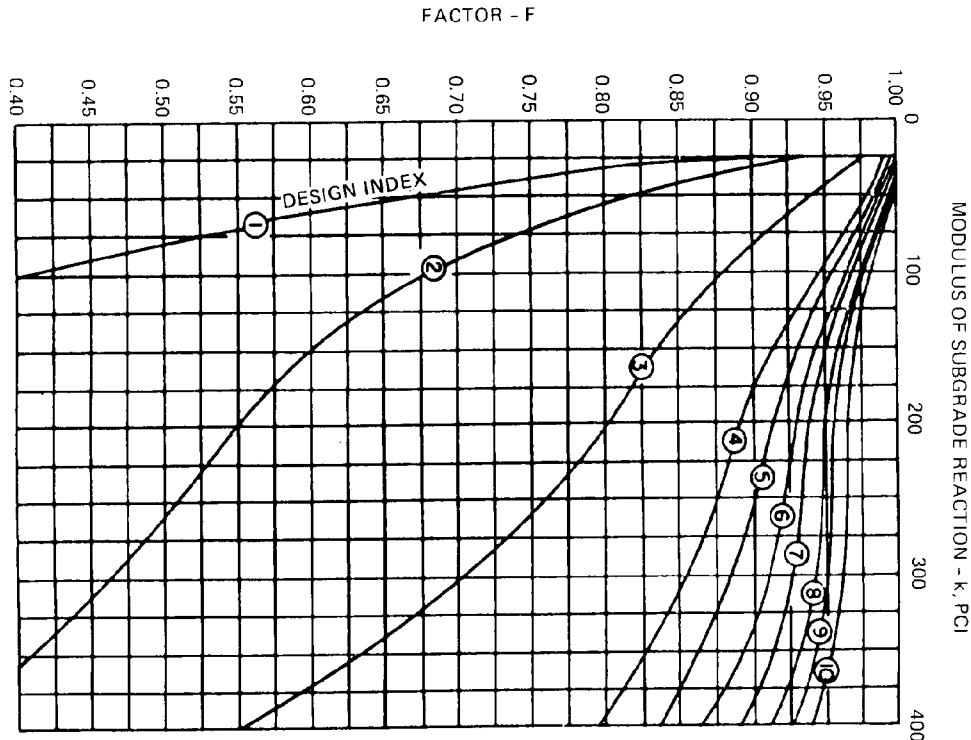

Figure 14-1. Factor for Projecting Cracking in a Flexible Pavement.

c. *Jointing* Normally, joints, other than those required for construction of a bituminous concrete pavement, will not be required in flexible overlays of existing rigid pavements. It is good practice to attempt to lay out paving lanes in the bituminous concrete to prevent joints in the overlay from coinciding with joints in the rigid base pavement. Movements of the existing rigid pavement, both from contraction and expansion and deflections due to applied loads, cause high concentrated stresses in the flexible overlay directly over joints and cracks in the existing rigid pavements. These stresses may result in cracking, often referred to as reflection cracks, in the overlay. The severity of this type cracking will, in part, depend upon the type of rigid pavement. For example, a plain concrete pavement normally will have closely spaced joints and may result in reflection cracks over the joints, but the cracks will be fairly tight and less likely to ravel. Nevertheless, reinforced concrete pavements will normally have joints spaced farther apart, which will, in turn, experience larger movements. The reflection cracks over these joints are more likely to ravel and spall. Likewise, either existing plain concrete or reinforced concrete pavements may have expansion joints that experience rather large movements, and consideration may be given to provide an expansion joint in the flexible overlay to coincide with the expansion joint in the existing pavement. No practical method has been developed to absolutely prevent reflective cracking in flexible overlays; however, experience has shown that the degree of cracking is related to the thickness of the overlay, with the thinner overlays exhibiting the greater tendency to crack.

14-9. Use of Geotextiles to Retard Reflective Cracking.

Geotextiles have been effective in retarding reflec-

tive cracking in some areas of the United States, as shown in figure 14-2. When geotextiles are used under an AC pavement, the existing pavement should be relatively smooth with all cracks larger than 1/4 inch sealed. A leveling course is also recommended before application of the fabric to ensure a suitable surface. A tack coat is also required prior to placement of the geotextile. The minimum overlay thickness is as shown in figure 14-2. When using geotextiles under a flexible pavement overlay, the geotextiles can be used as a membrane strip or a full-width application. The existing pavement should be stable with negligible movement under loads and all joints and cracks larger than 1/4 inch sealed. With the strip method, the geotextile is applied directly on the concrete joints and cracks and then overlaid. With the full-width method, the geotextile can be applied directly to the existing pavement or placed on a leveling course. It has also been observed that in flexible overlays, the lower viscosity (or higher penetration grade) asphalts are less likely to experience reflective cracking. Therefore, the lowest viscosity grade asphalt that will provide sufficient stability during high temperatures should be used.

14-10. Overlays in Frost Regions.

Whenever the subgrade is susceptible to differential heaving or weakening during the frost-melt period, the overlay design should meet the requirements for frost action as given in chapter 17. When it is determined that distress in an existing pavement has been caused by differential heaving due to frost action, an overlay may not correct the condition unless the combined thickness of the pavement is sufficient to prevent substantial frost penetration into the underlying frost-susceptible material.

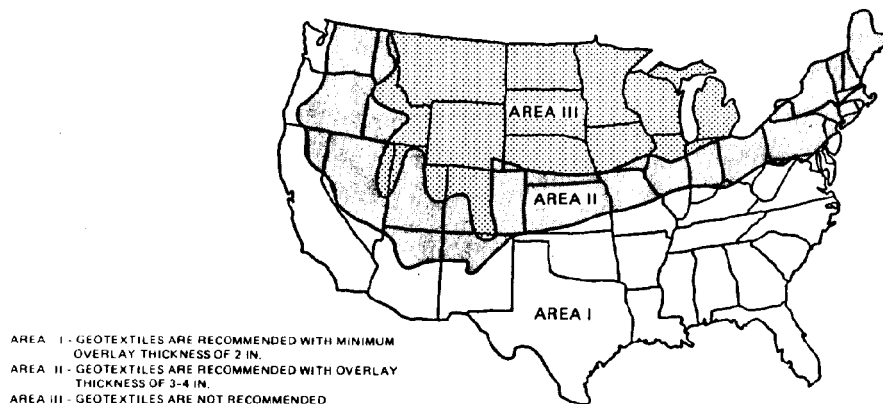

Figure 14-2. Location Guide for the Use of Geotextiles in Retarding Reflective Cracking.

14-11. Overlay Design Example.

Design an overlay for an existing road having a plain concrete thickness of 6 inches, a flexural strength of 650 psi, a subgrade k value of 100 pci, and a design index of 8. The concrete overlay will also have a flexural strength of 650 psi. The factor for projecting cracking in a flexible overlay is 0.975 from figure 14-1. The existing pavement is in good condition with little or no structural cracking. The condition factor C is therefore equal to 1.0 for concrete and flexible overlay. From figure 12-1, h_d and h_e are 8.6 inches. Overlay thickness requirements for the various types of overlays are as follows:

Bonded Overlay

$$h_o = h_d - h_g$$

$$h_o = 8.6 - 6.0$$

$$h_o = 2.6 \text{ inches (round to 3.0 inches)}$$

Partially Bonded Overlay

$$h_o = 1.4 \sqrt{h \frac{1.4}{d} - C \left(\frac{h_d}{h_e} \times h_E \right)^{1.4}}$$

$$h_o = 1.4 \sqrt{(8.6)^{1.4} - 1.0 \left(\frac{8.6}{8.6} \times 6.0 \right)^{1.4}}$$

$h_o = 4.4$ inches (use minimum thickness of 6 inches)

Unbonded Overlay

$$h_o = 2 \sqrt{h \frac{2}{d} - C \left(\frac{h_d}{h_e} \times h_E \right)^2}$$

$$h_o = 2 \sqrt{8.6^2 - 1.0 \left(\frac{8.6}{8.6} \times 6 \right)^2}$$

$h_o = 6.16$ inches (round to 6.5 inches)

Flexible Overlay

$$t_o = 3.0(Fh_d - Ch_g)$$

$$t_o = 3.0(0.975 \times 8.6 - 1.0 \times 6)$$

$$t_o = 7.2 \text{ inches (round to 7.5 inches)}$$

CHAPTER 15

JOINTS FOR PLAIN CONCRETE

15-1. Design Details.

A typical layout and cross section of a roadway is presented in figure 15-1 showing the location of various joint types. Figure 13-1 presents a layout of joints at intersections of plain concrete pavements. Figure 15-2 shows the layout of joints for plain concrete parking areas. Joints for RCCP are discussed in chapter 17.

15-2. Joint Types and Usage.

Joints are provided to permit contraction and ex-

pansion of the concrete resulting from temperature and moisture changes, to relieve warping and curling stresses due to temperature and moisture differentials, to prevent unsightly irregular breaking of the pavement, and as a construction expedient, to separate sections or strips of concrete placed at different times. The three general types of joints are contraction, construction, and expansion (see figs. 15-3 to 15-6).

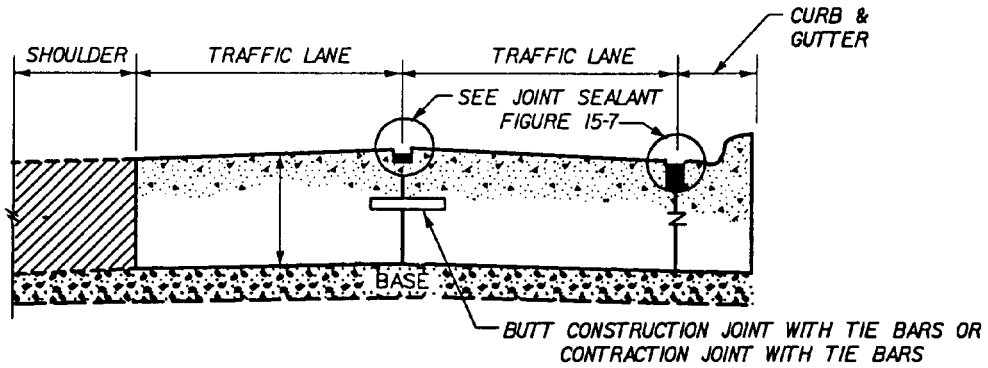

CROSS SECTION

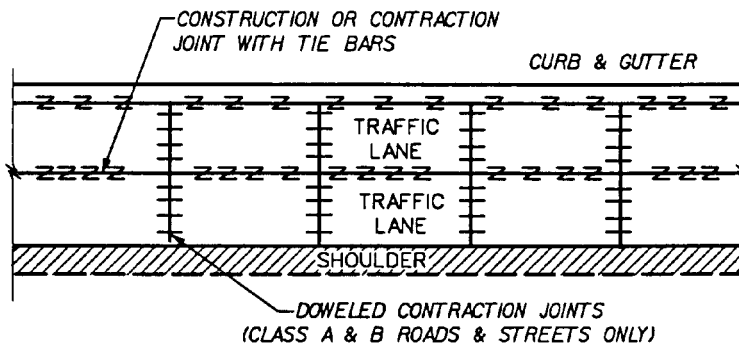

PLAN VIEW

- DOWEL:
- Z TIE BAR: NO. 5 DEFORMED STEEL BARS, 30" IN LENGTH, AND SPACED ON 30" CENTERS

Figure 15-1. Design Details for Plain Concrete Pavements. (Sheet 1 of 2)

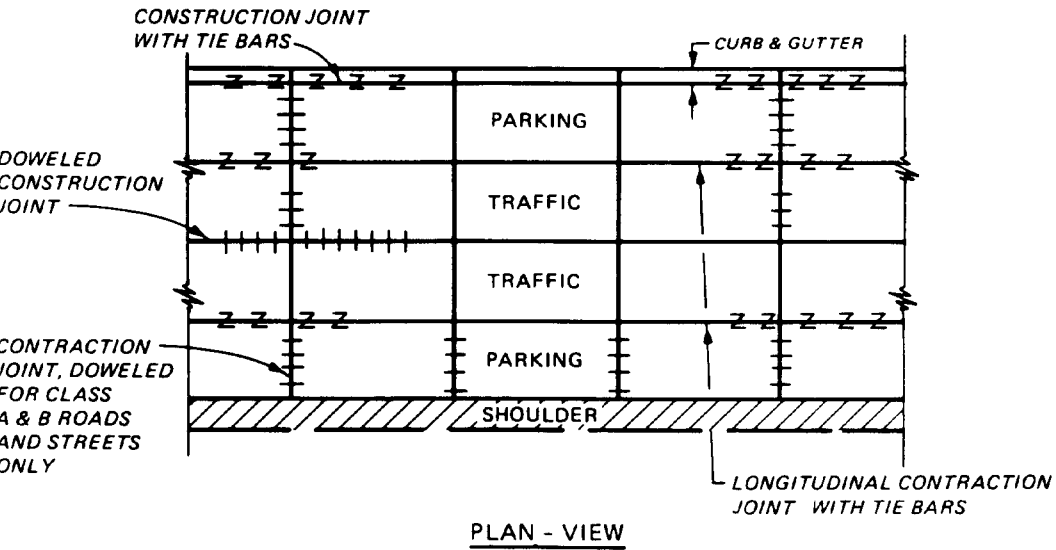
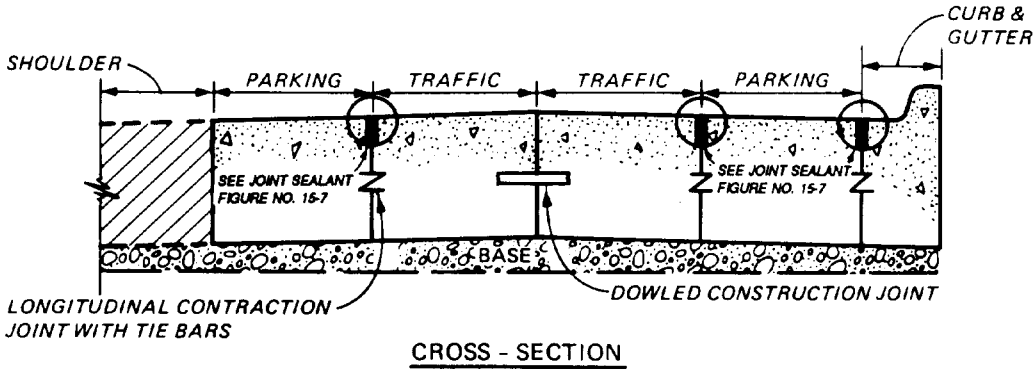

- DOWEL:
- Z TIE BAR: NO. 5 DEFORMED STEEL BARS, 30" IN LENGTH, AND SPACED ON 30" CENTERS.

Figure 15-1. Design Details for Plain Concrete Pavements. (Sheet 2 of 2)

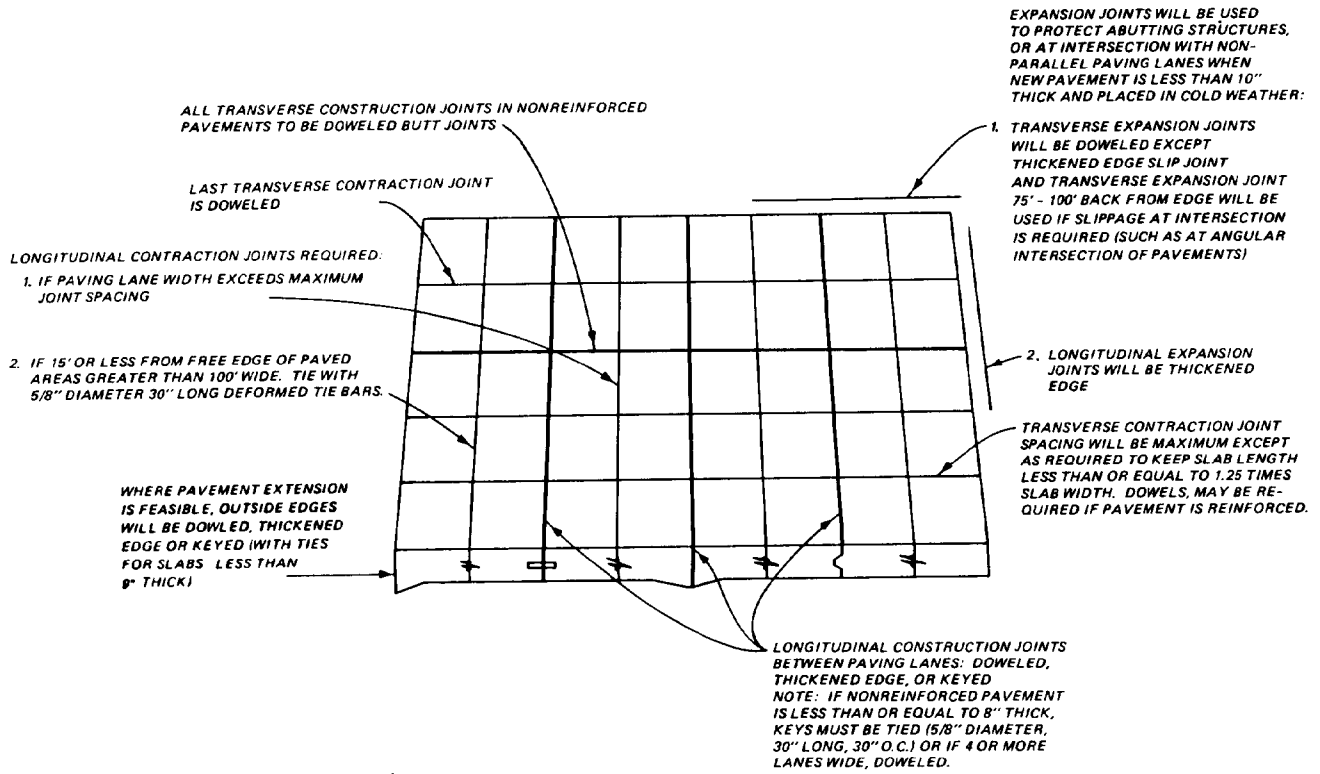
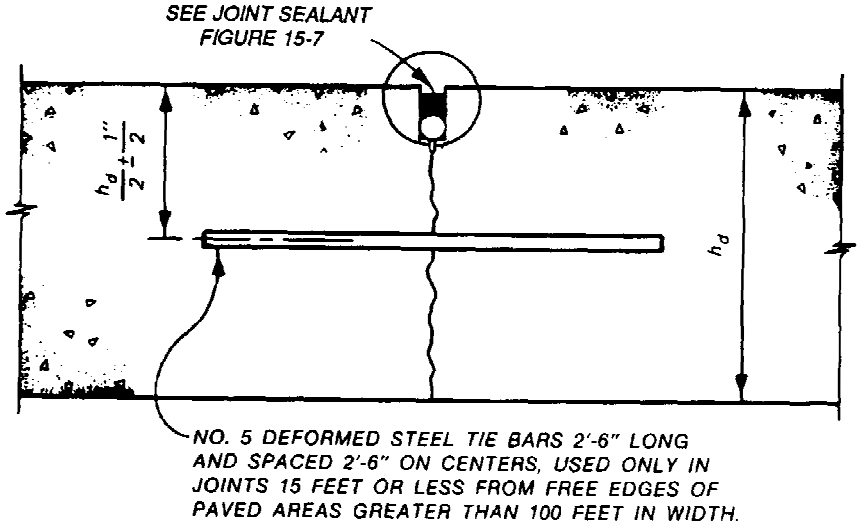
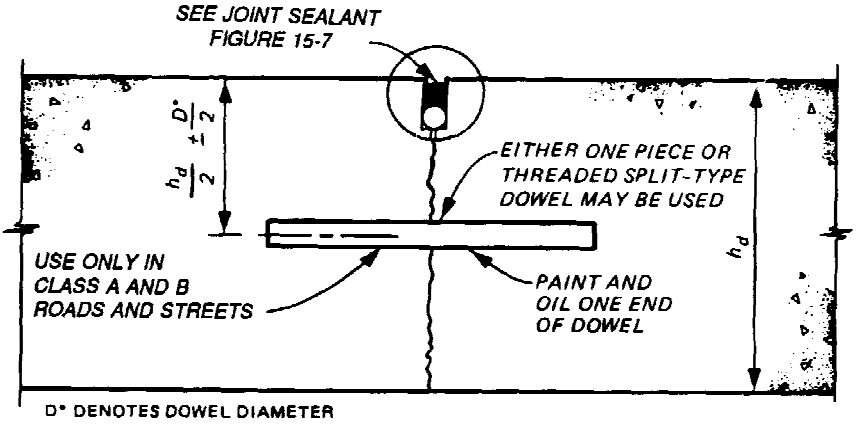

Figure 15-2. Joint Layout for Vehicular Parking Areas.



a. LONGITUDINAL



b. TRANSVERSE

Figure 15-3. Contraction Joints for Plain Concrete Pavements.

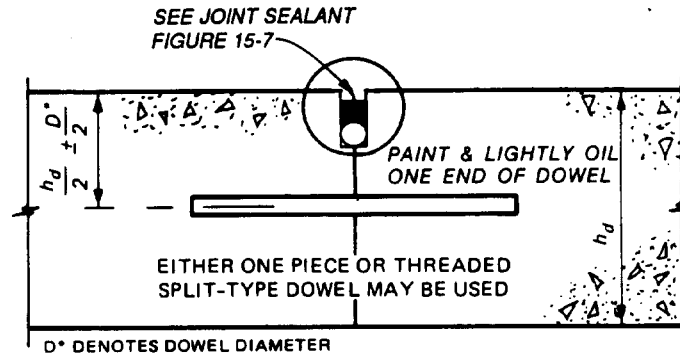

a. DOWELED TRANSVERSE OR LONGITUDINAL

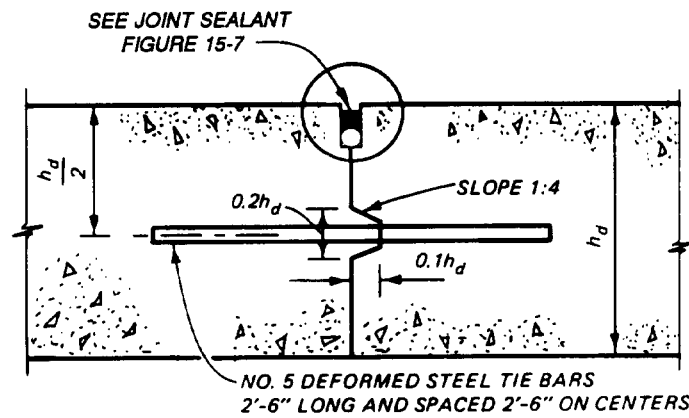

NOTES: TO BE USED ONLY WHEN SLAB THICKNESS IS 9 INCHES OR MORE
 A TOLERANCE OF $\pm 1/16$ " MAY BE ALLOWED FOR KEY DIMENSIONS AND LOCATION
 VERTICAL TOLERANCE OF $\pm 1/4$ " ALLOWED FOR PLACEMENT OF TIE BAR
 TIED JOINTS IN PAVEMENT WIDTH > 75 FT IS NOT RECOMMENDED.

b. KEYED AND TIED LONGITUDINAL

Figure 15-4. Construction Joints for Plain Concrete Pavements. (Sheet 1 of 4)

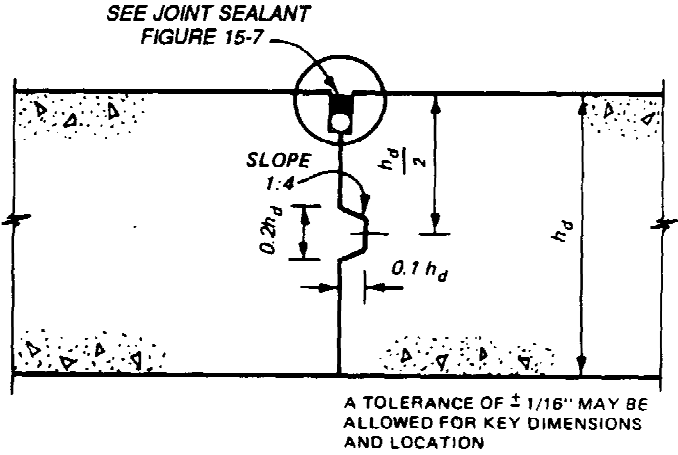

c. KEYED LONGITUDINAL

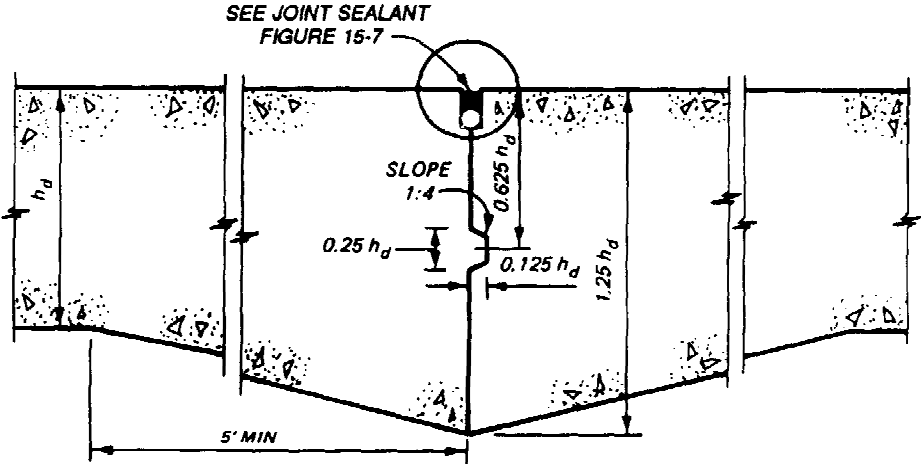

d. KEYED THICKENED EDGE LONGITUDINAL

Figure 15-4. Construction Joints for Plain Concrete Pavements. (Sheet 2 of 4)

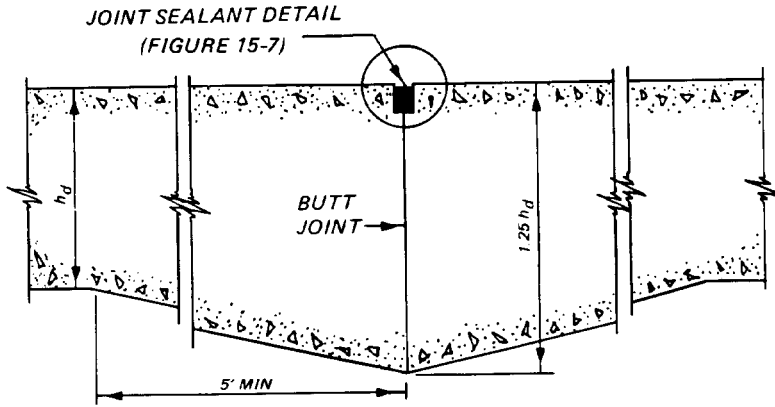

e. THICKENED EDGE LONGITUDINAL

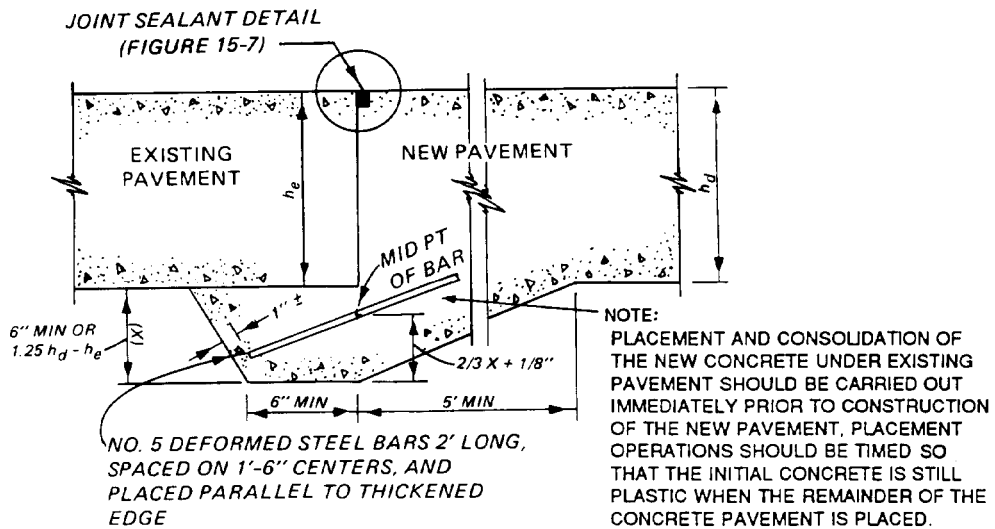

f. SPECIAL JOINT BETWEEN NEW AND EXISTING PAVEMENT TRANSVERSE OR LONGITUDINAL

Figure 15-4. Construction Joints for Plain Concrete Pavements. (Sheet 3 of 4)

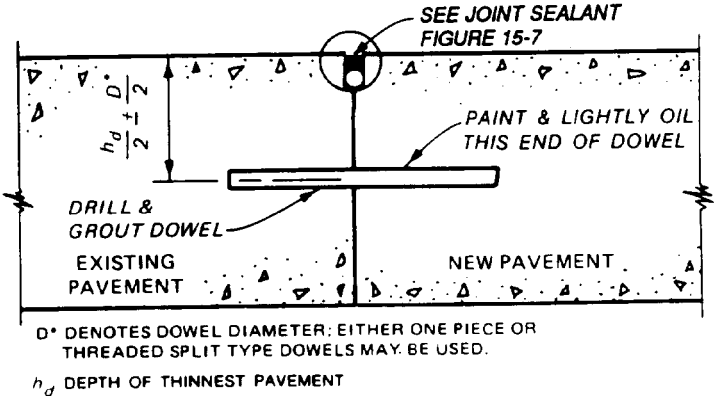

g. DOWELED JOINT BETWEEN
NEW AND EXISTING PAVEMENT

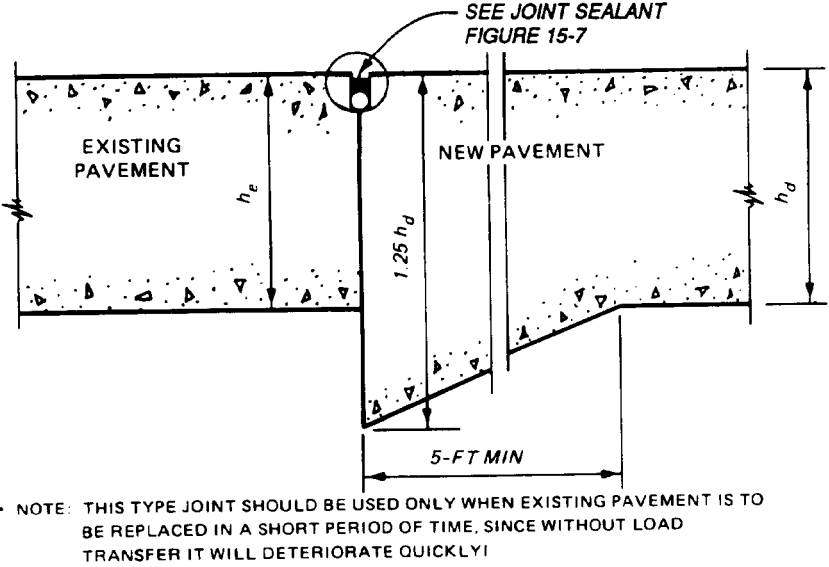

h. THICKENED-EDGED JOINT BETWEEN
NEW AND EXISTING PAVEMENT

Figure 15-4. Construction Joints for Plain Concrete Pavements. (Sheet 4 of 4)

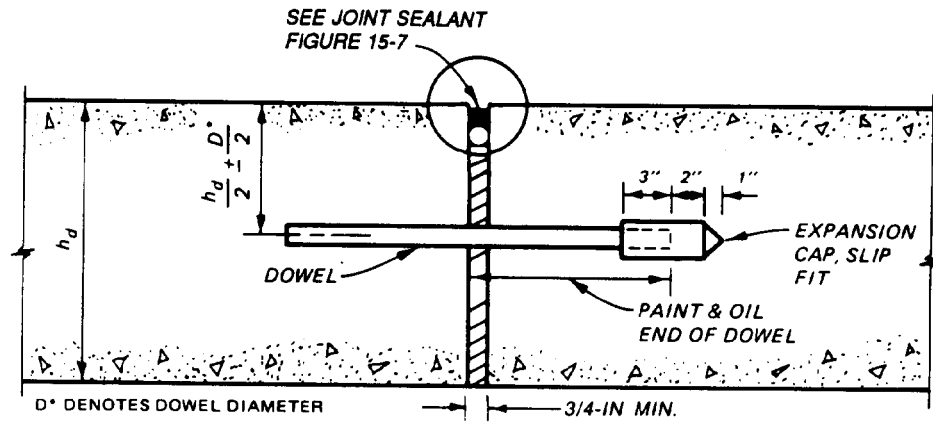

a. TRANSVERSE

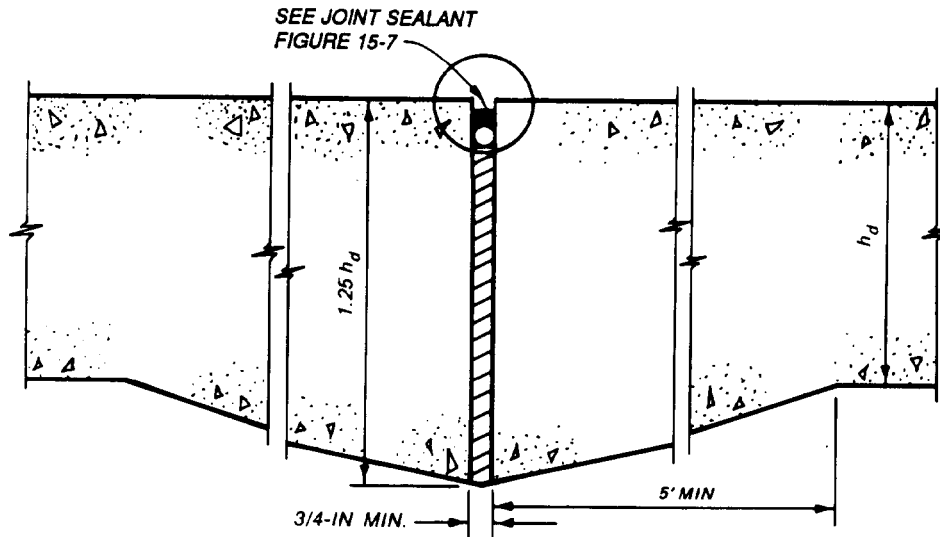

b. LONGITUDINAL

Figure 15-5. Expansion Joints for Plain Concrete Pavements.

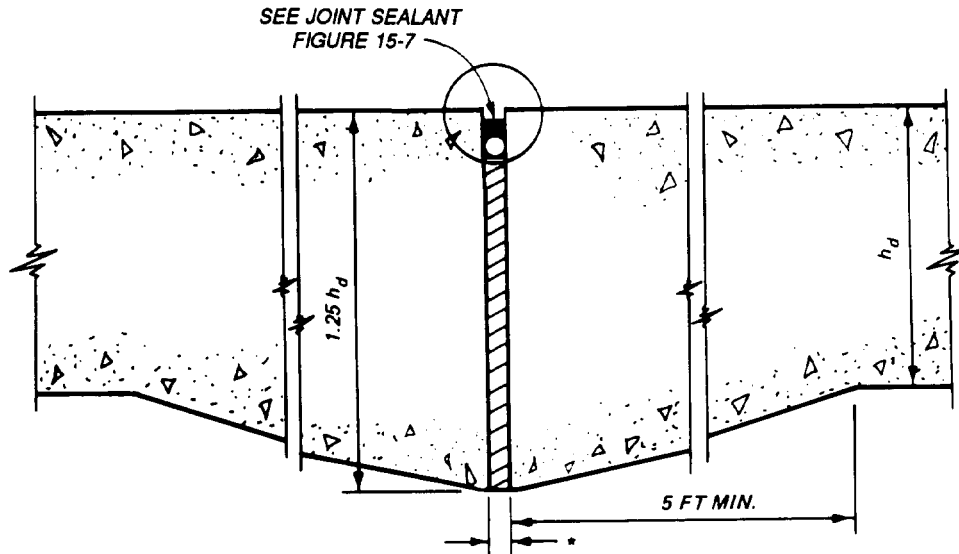

- * THE BOND-BREAKING MEDIUM WILL BE EITHER A HEAVY COATING OF BITUMINOUS MATERIAL NOT LESS THAN 1/16 INCH IN THICKNESS WHEN JOINTS MATCH OR A NORMAL NONEXTRUDING - TYPE EXPANSION JOINT MATERIAL 1/4 INCH IN THICKNESS WHEN JOINTS DO NOT MATCH.

Figure 15-6. Thickened-Edge Slip Joint.

a. *Contraction joints.* Weakened-plane contraction joints are provided to control cracking in the concrete and to limit curling or warping stresses resulting from drying shrinkage and contraction and from temperature and moisture gradients in the pavement, respectively. Shrinkage and contraction of the concrete cause slight cracking and separation of the pavement at the weakened planes, which will provide some relief from tensile forces resulting from foundation restraint and compressive forces caused by subsequent expansion. Contraction joints will be required transversely and may be required longitudinally depending upon pavement thickness and spacing of construction joints. Instructions regarding the use of sawcuts or preformed inserts to form the weakened plane are contained in TM 5-822-7.

(1) *Width and depth of weakened plane groove.* The width of the weakened plane groove will be a minimum of $\frac{1}{8}$ inch and a maximum equal to the width of the sealant reservoir. The depth of the weakened plane groove must be great enough to cause the concrete to crack under the tensile stresses resulting from the shrinkage and contraction of the concrete as it cures. Experience, supported by analyses, indicates that this depth should be at least one-fourth of the slab thickness for

pavements 12 inches or less, and 3 inches for pavements greater than 12 and less than 18 inches in thickness. In no case will the depth of the groove be less than the maximum nominal size of aggregate used. Concrete placement conditions may influence the fracturing of the concrete and dictate the depth of groove required. For example, concrete placed early in the day, when the air temperature is rising, may experience expansion rather than contraction during the early life of the concrete with subsequent contraction occurring several hours later as the air temperature drops. The concrete may have attained sufficient strength before the contraction occurs so that each successive weakened plane does not result in fracturing of the concrete. As a result, an excessive opening may result where fracturing does occur. To prevent such an opening, the depth of the groove will be increased to one-third of the slab thickness to assure the fracturing and proper functioning of each of the scheduled joints.

(2) *Width and depth of sealant reservoir.* The width and depth of the sealant reservoir for the weakened plane groove will conform to dimensions shown in figure 15-7. The dimensions of the sealant reservoir are critical to satisfactory performance of the joint sealing materials.

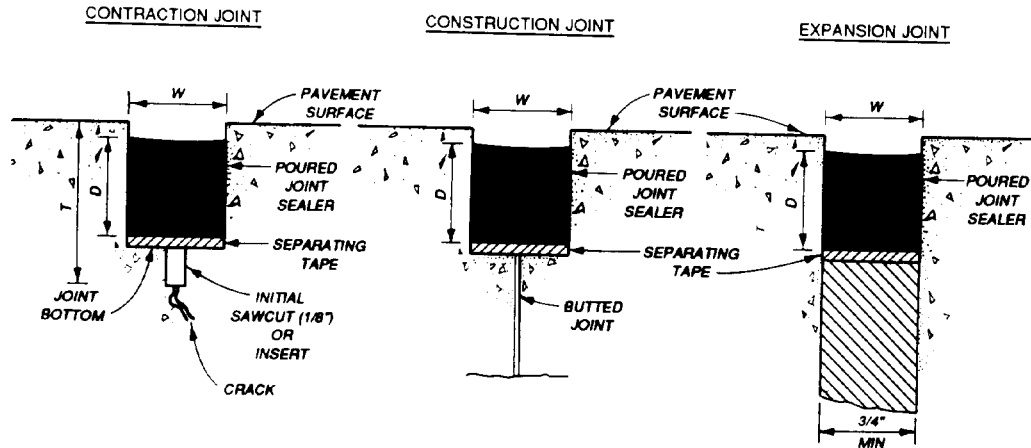

- W = WIDTH OF SEALANT RESERVOIR (SEE TABLE)
- D = DEPTH OF SEALANT (1.0 TO 1.5 X W)
- T = DEPTH OF INITIAL SAWCUT OR INSERT TYPE JOINT FORMER (CONTRACTION JOINT)
 - a. 1/4 SLAB THICKNESS FOR PAVEMENTS LESS THAN 12 INCHES
 - b. 3 INCHES FOR PAVEMENTS 12-18 INCHES*
 - c. 1/6 SLAB THICKNESS FOR PAVEMENTS MORE THAN 18 INCHES*

TABLE

| JOINT SPACING FT | WIDTH, IN | |
|---------------------|-----------|-------|
| | MIN | MAX |
| < 25 | 1/2 | 5/8 |
| 25 - 50 | 3/4 | 7/8 |
| > 50 | 1.0 | 1-1/8 |

*DESIGNER MAY WANT TO CONSIDER
REQUIRING 1/4 SLAB THICKNESS

NOTE TOP OF SEALANT WILL BE 1/8-IN TO 1/4-IN. BELOW TOP OF PAVEMENT

Figure 15-7. Joint Sealant Details. (Sheet 1 of 3)

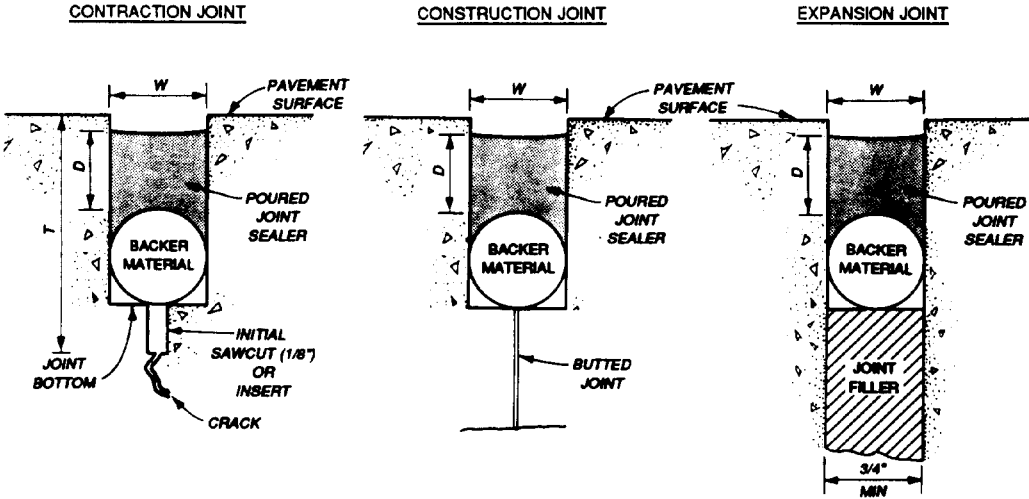

- W = WIDTH OF SEALANT RESERVOIR (SEE TABLE)
- D = DEPTH OF SEALANT (1.0 TO 1.5 X W)
- T = DEPTH OF INITIAL SAWCUT OR INSERT TYPE JOINT FORMER (CONTRACTION JOINT)
 - a. 1/4 SLAB THICKNESS FOR PAVEMENTS LESS THAN 12 INCHES
 - b. 3 INCHES FOR PAVEMENTS 12-18 INCHES*
 - c. 1/6 SLAB THICKNESS FOR PAVEMENTS MORE THAN 18 INCHES*

TABLE

| JOINT SPACING FT | WIDTH, IN. | |
|---------------------|------------|-------|
| | MIN | MAX |
| < 25 | 1/2 | 5/8 |
| 25 - 50 | 3/4 | 7/8 |
| > 50 | 1.0 | 1-1/8 |

*DESIGNER MAY WANT TO CONSIDER
REQUIRING 1/4 SLAB THICKNESS

NOTE: TOP OF SEALANT WILL BE 1/8-IN. TO 1/4-IN. BELOW TOP OF PAVEMENT.

Figure 15-7. Joint Sealant Details. (Sheet 2 of 3)

PREFORMED COMPRESSION SEAL

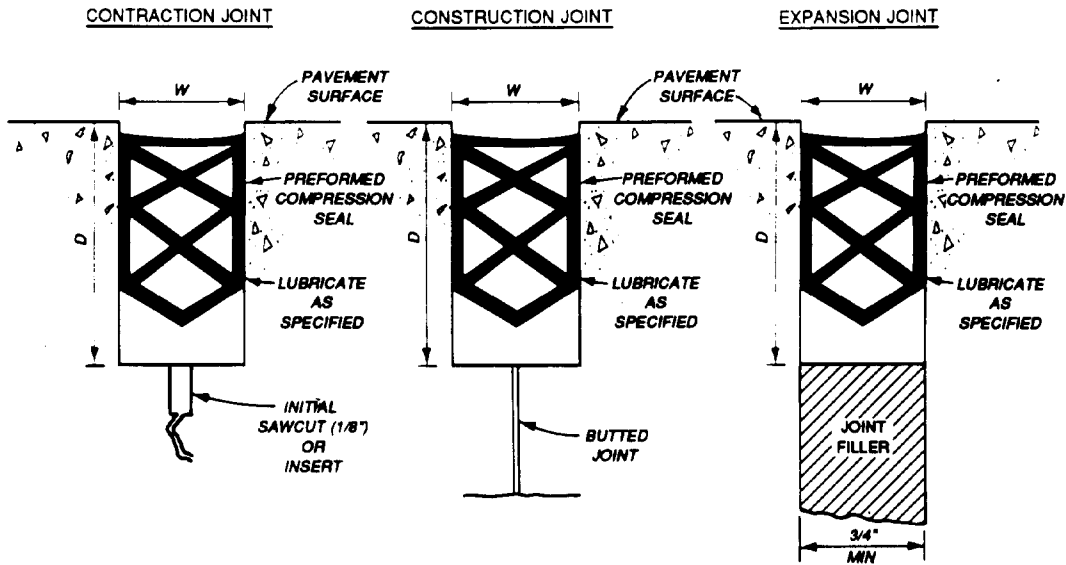

DEPTH & WIDTH: AS RECOMMENDED BY MANUFACTURER PER TYPE OF SEAL BEING USED, (DEPTH NOT LESS THAN 1.5 INCHES)

TOP OF PREFORMED SEAL WILL BE 1/8 - 1/4 INCH BELOW PAVEMENT SURFACE

COMPRESSION SEAL MUST BE IN COMPRESSION AT ALL TIMES.

| JOINT SPACING FT | WIDTH-IN. | |
|---------------------|-----------|-------|
| | MIN. | MAX. |
| < 25 | 1/2 | 5/8 |
| 25 - 50 | 3/4 | 7/8 |
| > 50 | 1.0 | 1-1/8 |

Figure 15-7. Joint Sealant Details (Sheet 3 of 3)

(3) *Spacing of transverse contraction joints.*

Transverse contraction joints will be constructed across each paving lane perpendicular to the center line, at intervals of not less than 12 1/2 feet, and generally not more than 25 feet (20 feet for Air Force). In regions where the design freezing index is 1,800 or more degree days the maximum spacing should be 20 feet. The joint spacing will be uniform throughout any major paved area, and each joint will be straight and continuous from edge to edge of the paving lane and across all paving lanes for the full width of the paved area. Staggering of joints in adjacent paving lanes can lead to sympathetic cracking and will not be permitted unless reinforcement is used. The maximum spacing of transverse joints that will effectively control cracking will vary appreciably depending on

pavement thickness, thermal coefficient and other characteristics of the aggregate and concrete, climatic conditions, and foundation restraint. It is impractical to establish limits on joint spacing that are suitable for all conditions without making them unduly restrictive. The joint spacings in table 15-1 have given satisfactory control of transverse cracking in most instances and should be used as a guide, subject to modification based on available information regarding the performance of existing pavements in the vicinity or unusual properties of the concrete. For best pavement performance, the number of joints should be kept to a minimum by using the greatest joint spacing that will satisfactorily control cracking. However, experience has shown that oblong slabs, especially in thin pavements, tend to crack into smaller slabs of nearly

equal dimensions under traffic. Therefore, it is desirable, insofar as practicable, to keep the length and width dimensions as nearly equal as possible. In no case should the length dimension (in the direction of paving) exceed the width dimension more than 25 percent. Where it is desired to exceed the joint spacing (in table 15-1), a request must be submitted to HQUSACE (CEMP-ET) or the appropriate Air Force Major Command outlining local conditions that indicate that the proposed change in joint spacing is desirable.

Table 15-2. Dowel Size and Spacing for Construction, Contraction, and Expansion Joints.

| Pave-ment thickness inches | Mini-mum dowel length inches | Maxi-mum dowel spacing inches | Dowel diameter and type |
|----------------------------|------------------------------|-------------------------------|--|
| Less than 8. | 16 | 12 | ¾-inch bar |
| 8 to 11..... | 16 | 12 | 1-inch bar |
| 12 to 15..... | 20 | 15 | 1- to 1¼-inch bar, or 1-inch extra strength pipe * |

* Extra strength pipe will be filled or plugged when used.

(4) *Spacing of longitudinal contraction joints.* Contraction joints will be placed along the center line of paving lanes that have a width greater than the determined maximum spacing of transverse contraction joints in table 15-1. These joints may also be required in the longitudinal direction for overlays, regardless of overlay thickness, to match joints existing in the base pavement unless a bond-breaking medium is used between the overlay and base pavement or the overlay pavement is reinforced.

(5) *Doweled and tied contraction joints.*

(a) Dowels are required in transverse contraction joints for plain concrete pavements for class A and B roads and streets, reinforced concrete pavements that use slab lengths greater than those in table 15-1, and in the last joint at ends of long paving lanes such as large storage and parking areas. These dowels are required to ensure good joint load transfer under heavy, repeated loads and under conditions where conventional contraction joints may have inadequate load transfer because of excessive joint opening. Table 15-2 presents the size and spacing of dowels.

Table 15-1. Maximum Allowable Spacing of Transverse Contraction Joints

| Pavement thickness, inches | Spacing of joint, feet |
|----------------------------|------------------------|
| Less than 9..... | 12½ to 15 |
| 9 to 12..... | 15 to 20 |
| Over 12..... | 20 to 25* |

*The maximum spacing of transverse contraction joints for Air Force pavements is 20 feet.

(b) For plain concrete pavements, deformed tie bars will be required in longitudinal contraction joints that fall 15 feet or less from the free edge of paved areas that are 100 feet or greater in width. The deformed tie bars will be 5/8 inch in diameter, 30 inches long, and spaced on 30-inch centers. In addition, longitudinal contraction joints placed along the center line of paving lanes that have a width greater than the maximum spacing of transverse contraction joints will be tied using tie bars of the above-mentioned dimensions (fig 15-3).

b. Construction joints. Construction joints may be required in both the longitudinal and transverse directions. Longitudinal construction joints, generally spaced 20 to 25 feet apart but which may reach 50 feet apart, depending on construction equipment capability, will be provided to separate successively placed paving lanes. Transverse construction joints will be installed at the end of each day's paving operation, and at other points within a paving lane where the placing of concrete is discontinued a sufficient length of time for the concrete to start to set. All transverse construction joints should be located in place of other regularly spaced transverse joints (contraction or expansion types). There are several types of construction joints available for use, as shown in figure 15-4 and as described below. The selection of the type of construction joint will depend on such factors as the concrete placement procedure (formed or slip-formed) and foundation conditions.

(1) *Doweled joint.* The doweled joint is the best joint for providing load transfer and maintaining slab alignment. It is a desirable joint for the most adverse conditions such as heavy loading, high traffic intensity, and lower strength foundations. However, because the alignment and placement of the dowel bars are critical to satisfactory performance, this type of joint is difficult to construct, especially for slipformed concrete. However, the doweled joint is required

for all transverse construction joints in plain concrete pavements.

(2) *Thickened-edge joint.* Thickened-edge-type joints may be used instead of other types of joints employing load transfer devices. When the thickened-edge joint is constructed, the thickness of the concrete at the edge is increased to 125 percent of the design thickness. The thickness is then reduced by tapering from the free-edge thickness to the design thickness at a distance of 3 feet from the longitudinal edge. The thickened-edge joint is considered adequate for the load-induced concrete stresses. However, the inclusion of a key in the thickened-edge joint (fig 15-4d) provides some degree of load transfer in the joint and helps to maintain slab alignment; although not required, it is recommended for pavement constructed on low-to medium-strength foundations. The thickened-edge joint may be used at free edges of paved areas to accommodate future expansion of the facility or where wheel loadings may track the edge of the pavement. The use of this type joint is contingent upon adequate base-course drainage meeting requirements of TM 5-820-2/AFM 88-5, Chap 2.

(3) *Keyed joint.* The keyed joint is the most economical method, from a construction standpoint, for providing load transfer in the joint. It has been demonstrated that the key or keyway can be satisfactorily constructed using either formed or slim formed methods. The required dimensions of the joint can best be maintained by forming or slim forming the keyway rather than the key. The dimensions and location of the key are critical to its performance. Deviations exceeding the stated tolerances can result in failure in the joint. Keyed joints should not be used in rigid pavements that are less than 9 inches in thickness. Tie bars in the keyed joint will limit opening of the joint and provide some shear transfer that will improve the performance of the keyed joints. However, tying all joints in pavement widths of more than 75 feet can result in excessive stresses and cracking in the concrete during contraction.

c. *Expansion joints.* Expansion joints will be used at all intersections of pavements with structures or with other concrete pavements where paving lanes are perpendicular to each other, and they may be required within the pavement features. A special expansion joint, the slip joint, is required at pavement intersections. The types of expansion joints are the thickened-edge joint, the thickened-edge slip joint, and the doweled type joint (see figs 15-5 and 15-6). Filler material for the thickened-edge and doweled type expansion joint will be a

nonextruding type. The type and thickness of filler material and the manner of its installation will depend upon the particular case. Usually, a preformed material of $\frac{3}{4}$ -inch thickness will be adequate; however, in some instances, a greater thickness of filler material may be required. Filler material for slip joints will be either a heavy coating of bituminous material not less than $\frac{1}{16}$ inch in thickness when joints match or a normal nonextruding-type material not less than $\frac{1}{4}$ inch in thickness when joints do not match. Where large expansions may have a detrimental effect on adjoining structures, such as at the juncture of rigid and flexible pavements, expansion joints in successive transverse joints back from the juncture should be considered. The depth, length, and position of each expansion joint will be sufficient to form a complete and uniform separation between the pavements or between the pavement and the structure concerned.

(1) *Between pavement and structures.* Expansion joints will be installed to surround, or to separate from the pavement, any structures that project through, into, or against the pavements, such as at the approaches to buildings or around drainage inlets. The thickened-edge-type expansion joint will normally be best suited for these places (see fig 15-5).

(2) *Within pavements and at pavement intersections.* Expansion joints within pavements are difficult to construct and maintain and often contribute to pavement failures. Their use will be kept to the absolute minimum necessary to prevent excessive stresses in the pavement from expansion of the concrete or to avoid distortion of a pavement through the expansion of an adjoining pavement. The determination of the need for and spacing of expansion joints will be based upon pavement thickness, thermal properties of the concrete, prevailing temperatures in the area, temperatures during the construction period, and the experience with concrete pavements in the area. Unless needed to protect abutting structures, expansion joints will be omitted in all pavements 10 inches or more in thickness and also in pavements less than 10 inches in thickness when the concrete is placed during warm weather since the initial volume of the concrete on hardening will be at or near the maximum. However, for concrete placed during cold weather, expansion joints may be used in pavements less than 10 inches thick.

(a) Longitudinal expansion joints within pavements will be of the thickened-edge type (see fig 15-5). Dowels are not recommended in longitu-

dinal expansion joints because differential expansion and contraction parallel with the joints may develop undesirable localized strains and cause failure of the concrete, especially near the corners of slabs at transverse joints. Expansion joints are not required between two adjoining pavements where paving lanes of the two pavements are parallel.

(b) Transverse expansion joints within pavements will be the doweled type (see fig 15-5). There may be instances when it will be desirable to allow some slippage in the transverse joints such as at the angular intersection of pavements to prevent the expansion of one pavement from distorting the other. Then, the design of the transverse expansion joints will be similar to the thickened-edge slip joints (see para 15-6). When a thickened-edge slip joint is used at a free edge not perpendicular to a paving lane, a transverse expansion joint will be provided 75 to 100 feet back from the free edge.

15-3. Dowels.

The important functions of dowels or any other load-transfer device in concrete pavements are to help maintain the alignment of adjoining slabs and to transfer some stresses from loads to the adjacent slab, thereby limiting or reducing stresses in the loaded slab. Different sizes of dowels will be specified for different thicknesses of pavements (see table 15-2). When extra strength pipe is used for dowels, the pipe will be filled with either a stiff mixture of sand-asphalt or portland cement mortar or the ends of the pipe will be plugged. If the ends of the pipe are plugged, the plug must fit inside the pipe and be cut off flush with the end of the pipe so that there will be no protruding material to bond with the concrete and prevent free movement of the dowel. Figures 15-1 and 13-1 show the dowel placement. All dowels will be straight, smooth, and free from burrs at the ends. One end of the dowel will be painted and oiled to prevent bonding with the concrete. Dowels used at expansion joints will be capped at one end, in addition to painting and oiling, to permit further penetration of the dowels into the concrete when the joints close.

15-4. Special Provisions for Slipform Paving.

Provisions must be made for slipform pavers when there is a change in longitudinal joint configuration. The thickness may be varied without stopping the paving train, but the joint configuration cannot be varied without modifying the side forms, which will normally require stopping the paver and installing a header. The following requirements shall apply at a pavement transition area.

a. *Header.* The header may be set on either side of the transition slab with the transverse construction joint doweled, as required. The dowel size and location in the transverse construction joint should be commensurate with the thickness of the pavement at the header.

b. *Transition between different joints.* When there is a transition between a doweled longitudinal construction joint and a keyed longitudinal construction joint, the longitudinal construction joint in the transition slab may be either keyed or doweled. The size and location of the dowels or keys in the transition slabs should be the same as those in the pavement with the doweled or keyed joint, respectively.

c. *Transition between two keyed joints.* When there is a transition between two keyed joints with different dimensions, the size and location of the key in the transition slab should be based on the thickness of the thinner pavement.

15-5. Joint Sealing.

All joints will be sealed to prevent infiltration of surface water and solid substances. Details of the joint sealant are shown in figure 15-7. A jet-fuel resistant (JFR) sealant, either poured or preformed, will be used in the joints of hardstands, washracks, and other paved areas where fuel or other lubricants may be spilled during the operation, parking, maintenance, and servicing of vehicles. Sealants that are not fuel resistant will be used in joints of all other pavements. Poured JFR sealants will conform to Federal Specifications SS-S-200E and SS-S-1614A, and poured non-JFR sealants will conform to Federal Specification 55-S-1401C. Use of SS-S-1401C requires MACOM approval for use on Air Force Projects. Cold poured non-JFR sealants will conform to CRD-C 527. Preformed sealants will conform to ASTM D 2628 and tested according to the procedures in appendix C for jet-fuel resistance. Lubricant for preformed sealants will conform to ASTM D 2835. Preformed sealants must always be compressed 45 to 85 percent of their original width. The selection of pour-able or preformed sealant should be based upon economics. Compression-type preformed sealants are recommended when the joint spacings exceed 25 feet and are required when joint spacings exceed 50 feet.

15-6. Special Joints and Junctures.

Situations will develop where special joints or variations of the more standard type joints will be needed to accommodate the movements that will occur and to provide a satisfactory operational sur-

TM 5-822-5/AFM 88-7, Chap. 1

face. Some of these special joints or junctures are as follows:

a. Slip-type joints. At the juncture of two pavement facilities, expansion and contraction of the concrete may result in movements that occur in different directions. Such movements may create detrimental stresses within the concrete unless provision is made to allow the movements to occur. At such junctures, a thickened-edge slip joint shall be used to permit the horizontal slip to occur. The design of the thickened-edge slip joint will be similar to the thickened-edge construction joint (see fig 15-6). The bond-breaking medium will be either a heavy coating of bituminous material not less than $\frac{1}{16}$ inch in thickness when joints match or a normal nonextruding-type expansion joint material not less than $\frac{1}{4}$ inch in thickness when joints do not match. The $\frac{1}{16}$ -inch bituminous coating may be either a low penetration (60 to 70 grade asphalt) or a clay-type asphalt-base emulsion similar to that used for roof coating (see Military Specification MIL-R-3472) and will be applied to the face of the joint by hand brushing or spraying.

b. Joints between new and existing pavements. A special thickened-edge joint design (see fig 15-4f) will be used at the juncture of new and existing pavements for the following conditions:

(1) When load-transfer devices (keyways or dowels) or a thickened edge was not provided at the free edge of the existing pavement.

(2) When load-transfer devices or a thickened

edge was provided at the free edge of the existing pavement, but neither met the design requirements for the new pavement.

(3) For transverse contraction joints, when removing and replacing slabs in an existing pavement.

(4) For longitudinal construction joints, when removing and replacing slabs in an existing pavement if the existing load-transfer devices are damaged during the pavement removal.

(5) Any other location where it is necessary to provide load transfer for the existing pavements. The special joint design may not be required if a new pavement joins an existing pavement that is grossly inadequate to carry the design load of the new pavement or if the existing pavement is in poor structural condition. If the existing pavement can carry a load that is 75 percent or less of the new pavement design load, special efforts to provide edge support for the existing pavement may be omitted and the alternate thickened-edge joint used (fig 15-4h); however, if omitted, accelerated failures in the existing pavement may be experienced. The new pavement will simply be designed with a thickened edge at the juncture. Any load-transfer devices in the existing pavement should be used at the juncture to provide as much support as possible to the existing pavement. Drilling and grouting dowels in the existing pavement for edge support may be considered as an alternate to the special joint; however, a thickened-edge design will be used for the new pavement at the juncture.

CHAPTER 16

JOINTS FOR REINFORCED CONCRETE

16-1. Requirements.

Figures 16-1 through 16-3 present details of the contraction, construction, and expansion joints in reinforced concrete pavements. Joint requirements

and types of reinforced concrete pavements will be the same as for plain concrete pavements (see chap 15) except for those listed below.

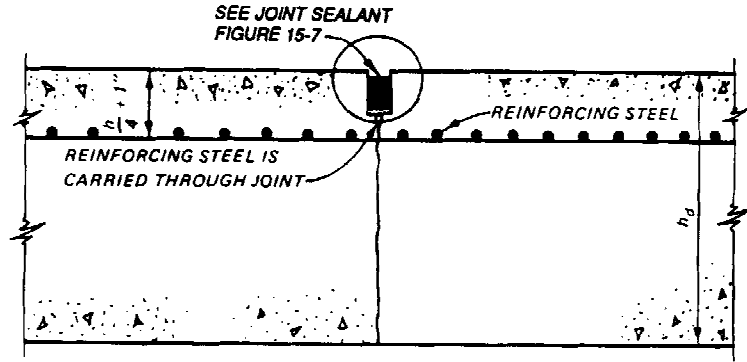

NOTE: SAW CUT WILL NOT EXTEND BELOW STEEL REINFORCING.

a. LONGITUDINAL

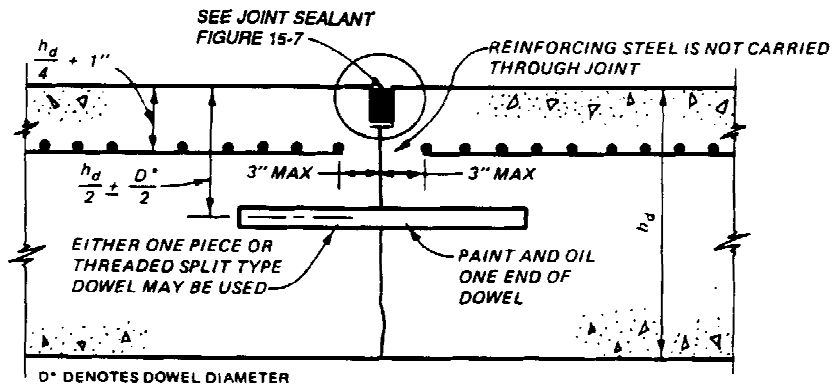

b. TRANSVERSE

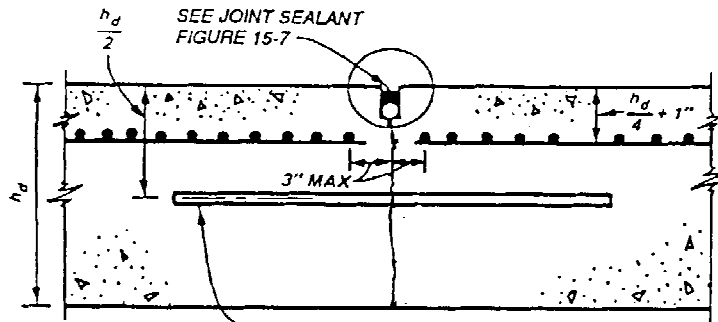

c. TIED LONGITUDINAL

Figure 16-1. Contraction Joints for Reinforced Concrete Pavements.

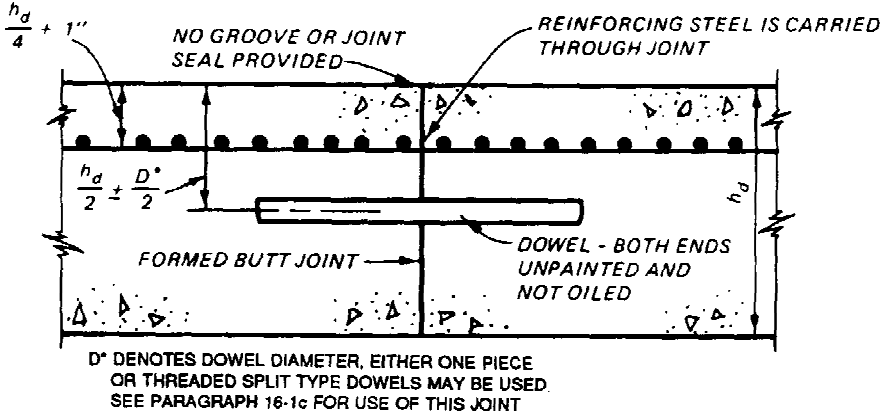

a. DOWELED TRANSVERSE

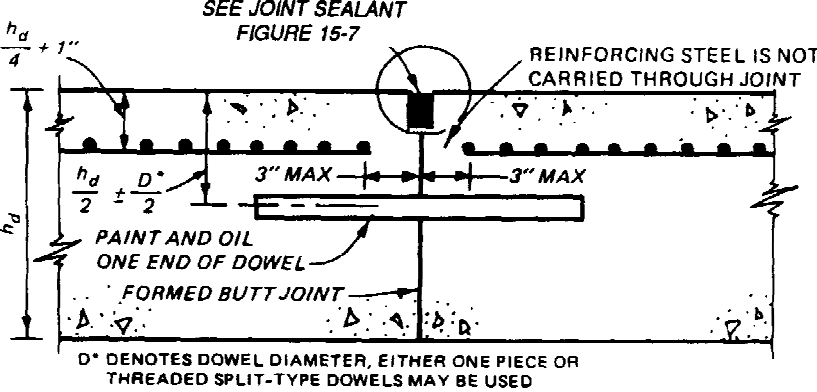

b. DOWELED TRANSVERSE OR LONGITUDINAL

Figure 16-2. Construction Joints for Reinforced Concrete Pavements. (Sheet 1 of 4)

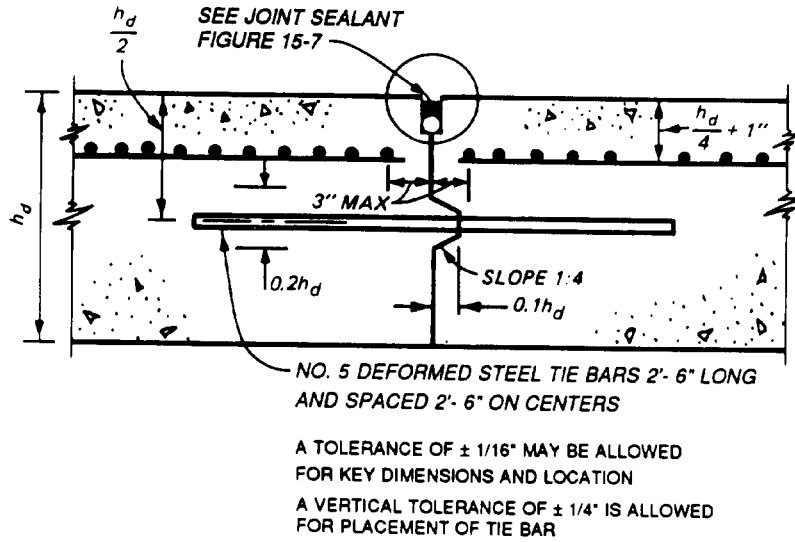

c. KEYED AND TIED LONGITUDINAL

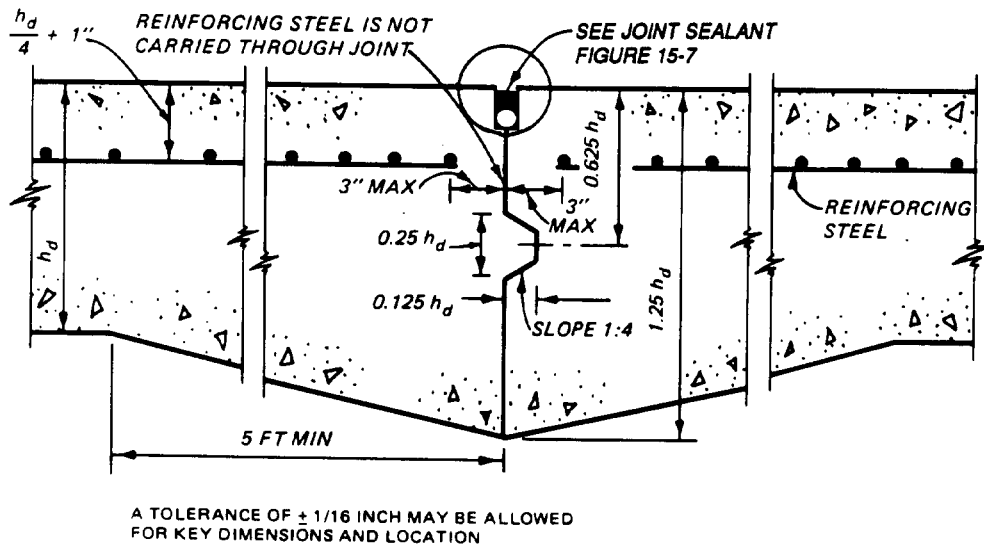

d. KEYED THICKENED EDGE LONGITUDINAL

Figure 16-2. Construction Joints for Reinforced Concrete Pavements. (Sheet 2 of 4)

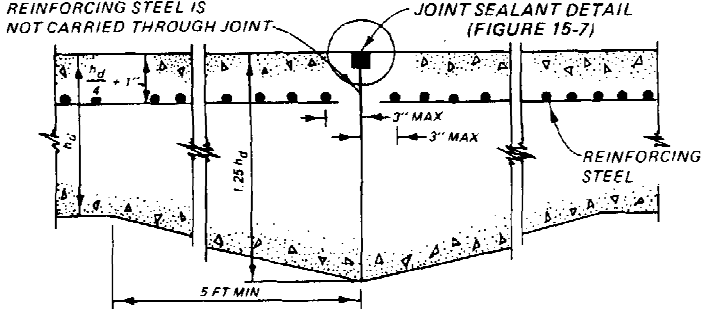

e. THICKENED EDGE LONGITUDINAL

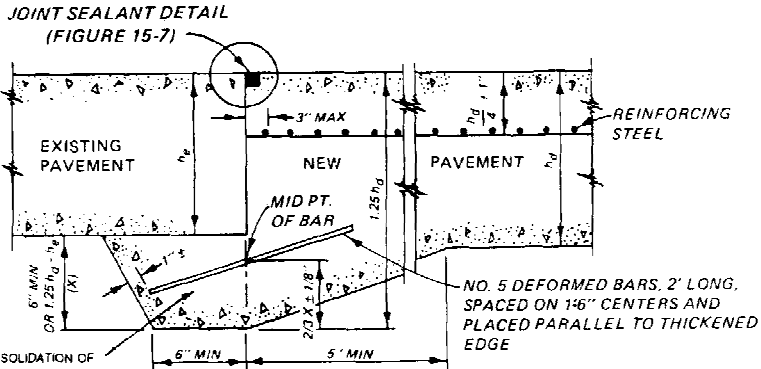

NOTE: PLACEMENT AND CONSOLIDATION OF THE NEW CONCRETE UNDER EXISTING PAVEMENT SHOULD BE CARRIED OUT IMMEDIATELY PRIOR TO CONSTRUCTION OF THE NEW PAVEMENT. PLACEMENT OPERATIONS SHOULD BE TIMED SO THAT THE INITIAL CONCRETE IS STILL PLASTIC WHEN THE REMAINDER OF THE CONCRETE PAVEMENT IS PLACED.

f. SPECIAL JOINT BETWEEN NEW AND EXISTING PAVEMENTS

Figure 16-2. Construction Joints for Reinforced Concrete Pavements. (Sheet 3 of 4)

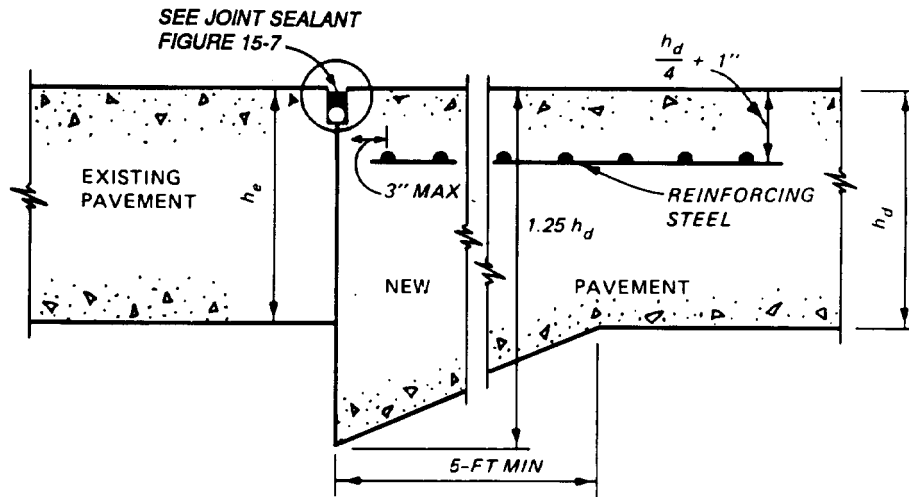

• NOTE: THIS TYPE JOINT SHOULD BE USED ONLY WHEN EXISTING PAVEMENT IS TO BE REPLACED IN A SHORT PERIOD OF TIME, SINCE WITHOUT LOAD TRANSFER, IT WILL DETERIORATE QUICKLY.

g. THICKENED-EDGE JOINT BETWEEN NEW AND EXISTING PAVEMENT

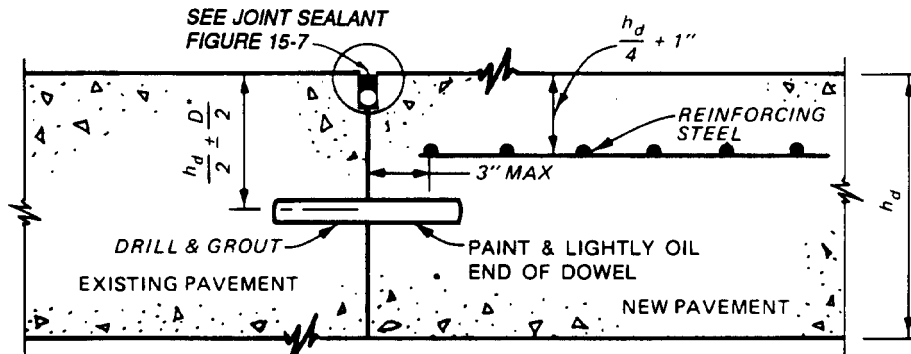

D* DENOTES DOWEL DIAMETER, EITHER ONE PIECE OR THREADED SPLIT TYPE DOWELS MAY BE USED

h. DOWELED JOINT BETWEEN NEW AND EXISTING PAVEMENT

Figure 16-2. Construction Joints for Reinforced Concrete Pavements. (Sheet 4 of 4)

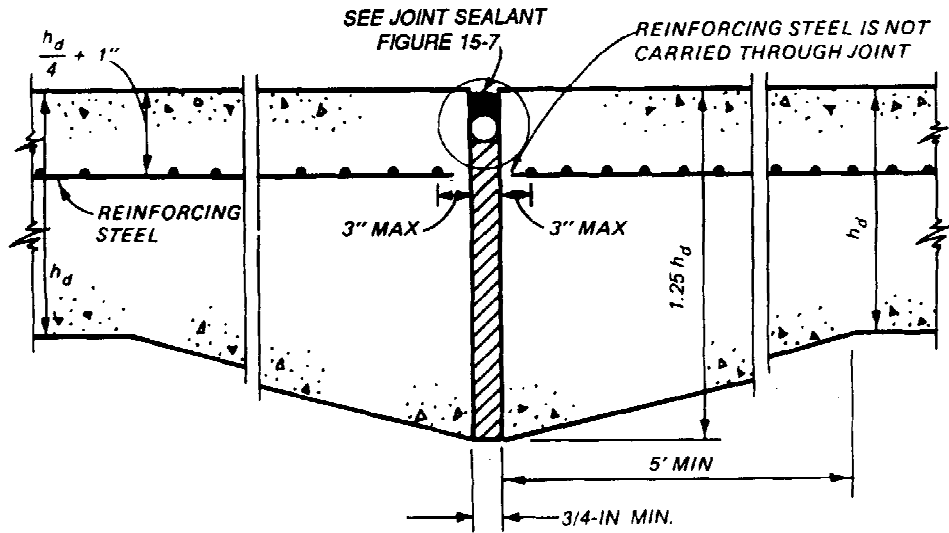

a. LONGITUDINAL

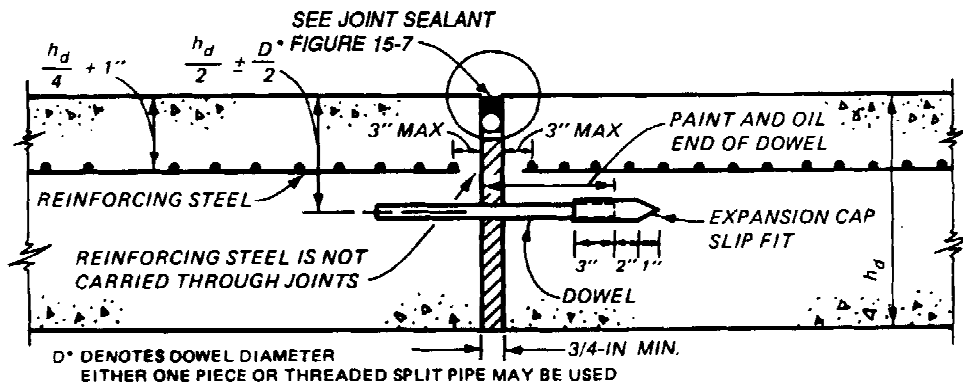

b. TRANSVERSE

Figure 16-3. Expansion Joints for Reinforced Concrete Pavements.

a. *Unscheduled joints.* All joints falling at a point other than a regularly scheduled transverse contraction joint will be doweled with the exception of the thickened-edge type. One end of the dowel will be painted and oiled to permit movement at the joint.

b. *Thickened-edge-type joints.* Thickened-edge-type joints will not be doweled. The edge will be thickened to 125 percent of the design thickness.

c. *Transverse construction joint.* When a transverse construction joint is required within a reinforced concrete slab unit, not at a regularly scheduled contraction joint location, the reinforcing steel will be carried through the joint. In addition, dowels meeting the size and spacing requirements of table

15-2 for the design thickness will be used in the joint.

d. *Transverse contraction joints.* Transverse contraction joints in reinforced concrete pavements should be constructed across each paving lane, perpendicular to the pavement center line, and at intervals of not less than 25 feet nor more than 75 feet. The maximum allowable slab width or length for reinforced concrete pavements is a function of the effective frictional restraint developed at the interface between the slab and subgrade, the percentage of steel reinforcing used in the slab, and the yield strength of the steel reinforcing. Allowable slab widths or lengths can be determined directly from figure 13-2 for yield strengths of 60,000 psi.

TM 5-822-5/AFM 88-7, Chap. 1

If it is desired to use reinforcing steel having a yield strength other than this value, the maximum allowable slab width or length can be determined from equation 16-1.

$$L = \left[0.00047 h_r (f_s S)^2 \right]^{1/2} \quad (\text{eq 16-1})$$

where

h_r = thickness of reinforced concrete pavement, inches

f_s = yield strength of reinforcing steel, psi

S = percent of reinforcing steel

e. Two traffic lanes. For reinforced concrete pavements where two traffic lanes are placed as a single paving lane, a longitudinal contraction joint should be provided at the center line of the paving lane to control cracking. In these joints, the reinforcing steel is carried through the joint, and tie bars are not required.

f. Pavement center line. Tied longitudinal contraction joints are also required at the center line of reinforced concrete pavements when the width of the pavement exceeds the allowable length of slab L for the percentage of steel reinforcement being used. When such joints are required, the steel reinforcement should be broken at the joint, and 5/8-inch-diameter tie bars 30 inches long and spaced 30-inch center to center are used.

16-2. Joint Sealing.

Joint sealing for reinforced concrete pavements will be the same as for plain concrete pavements (see para 15-5). The use of preformed compression sealants will be required when the joint spacing exceeds 50 feet.

CHAPTER 17

ROLLER-COMPACTED CONCRETE PAVEMENTS

17-1. Introduction.

Roller-compacted concrete pavement (RCCP) is a zero-slump portland cement concrete mixture that is placed with an asphalt concrete paving machine and compacted with vibratory and rubber-tired rollers. Mixture proportions and most engineering properties of RCCP are similar to those of conventional plain concrete pavements. The mixture proportions of RCCP are not appreciably different than those used in conventional concrete; flexural strengths of beams taken from RCCP facilities and test sections routinely exceed 650 psi at 28 days. Limited tests have shown that the fatigue characteristics of RCCP mixtures are similar to those of conventional concrete pavement mixtures. In Canada under moderately severe environmental and heavy loading conditions, RCCP hardstands have performed well for over 10 years alongside conventional concrete hardstands. Therefore, it may be assumed that the same rationale applied to the thickness design for plain nonreinforced concrete pavement thickness may also be applied to the design of RCCP.

17-2. Load Transfer.

A major difference exists in the assumptions of load transfer at joints made for plain concrete pavements and RCCP, which directly effects the design stress and therefore the thickness of the pavement. RCCP has typically been allowed to crack naturally, and spacings between these cracks are usually irregular, ranging from 40 to 70 feet apart (although spacings much greater and much lower than these have been reported). Consequently, the width of the crack opening will be greater and the load transfer developed from aggregate interlock at the cracks will be highly variable, if not totally lost. Limited tests at Fort Hood, TX, and Fort Steward, GA, have revealed average load transfer at transverse contraction cracks of 18.6 percent (standard deviation of 6.7 percent) and longitudinal cracks 16.7 percent (standard deviation of 5.9 percent), respectively. Tests on longitudinal and transverse cold (construction) joints revealed even less load transfer. Therefore, the assumption of 25 percent load transfer at joints in open storage areas constructed of plain concrete would not be valid for RCCP thickness design. The approach then would be to base the thickness design of RCCP on no load

transfer at the joints, i.e. assuming all joints/cracks to be a free edge condition.

17-3. Thickness Design.

The thickness design curves shown in figure 12-1 will be used to determine thickness requirements for RCCP. These curves are the same as used for plain concrete roads and streets.

17-4. Multilift Pavements.

The maximum lift thickness that can be placed at an acceptable grade and smoothness and compacted to a uniform density is about 10 inches. Therefore, if the RCCP design thickness is greater than 10 inches, two or more lifts will be necessary to achieve the design thickness. If possible, the upper lift should be of minimal thickness, preferably one-third of the total pavement thickness (but no less than 4 inches), to aid in creating a smoother surface finish. The type of bond achieved between the lifts is a function of the construction sequence and timing and will govern the method of thickness design used for multilift RCCP. The three types of bonding conditions to be considered in RCCP thickness design are full bond, partial bond, and no bond.

a. Full bond. Full bond may be assumed between adjacent lifts if they are placed and compacted within 1 hour of each other, or if a thin grout is placed between the upper and lower lifts. The surface of the lower lift must be kept clean and moist until the upper lift is placed and should not be rolled with the rubber-tired roller. If the full bond condition is achieved, the thickness should be determined as if a monolithic slab were used, with no consideration for the joint between lifts in the thickness design calculations.

b. Partial bond. Partial bond should be assumed between subsequent lifts if they are placed and compacted more than 1 hour apart. The surface of the lower lift must be kept clean and moist until the upper lift is placed. The thickness should be designed as a rigid overlay of a rigid base pavement with partial bonding according to the guidance in chapter 14.

c. No bond. No bond may be assumed between adjacent lifts if some type of bond breaker is used between the lifts, such as a curing compound or asphalt emulsion sprayed on the surface of the lower lift. The thickness should be designed as a

rigid overlay of a rigid base pavement with no bond, according to the guidance in chapter 14.

17-5. Joint Types for RCC.

a. Expansion joints. Expansion joints, within an area paved with RCC, will not be required except to protect facilities located within the paved area.

b. Contraction joints. Generally, longitudinal contraction joints will not be required in RCC pavements. However, most RCC pavement to date has been allowed to crack naturally in the transverse direction. These cracks usually occur randomly at 40- to 70-foot spacings, and have performed well, with little raveling or faulting. The natural cracks are typically not sealed; however, it is recommended that all cracks be routed and sealed in areas where the pavement may be susceptible to frost damage. Sawing of contraction joints is recommended at spacings of 50 to 75 feet, providing the sawing can be accomplished in the first 24 hours without excessive raveling. The optimum time for sawing and optimum transverse joint spacing should be determined during the test section construction. Depth of sawcut should be one-third of the pavement thickness. For multilift pavements, the sawcut should be made one-third the pavement depth if full bond conditions are used. If partial bond or no bond conditions are used, the sawcuts should be made in each lift in coinciding locations to one-third the lift thickness (the sawcuts in the lower lifts may be made 1 hour after compaction).

The longitudinal and transverse cold joints for each lift should always coincide. All sawed joints should be sealed.

c. Construction joints. Currently, there are two types of construction joints in RCC paving—fresh and cold. When fresh concrete can be placed and compacted against in-place concrete prior to initial set (usually within 90 minutes), the juncture or joint will be considered to be a fresh joint and no special treatment will be required. For the construction of a fresh joint, the edge of the in-place concrete is left uncompacted and rolled after the adjoining concrete has been placed. When the in-place RCC has stiffened significantly before the adjoining fresh concrete can be placed (usually around 90 minutes), the resulting juncture will be considered a cold construction joint. The in-place concrete must be fully compacted and then the edge trimmed back to solid concrete to form a near vertical face. If the required density or smoothness is not obtained, then the in-place concrete must be removed. Immediately prior to placement of the adjoining concrete, the vertical edge should be dampened. After placement of the fresh concrete, the excess which spills onto the compacted material should be pushed back to the edge of the fresh concrete before rolling. No effort will be made to achieve load transfer at the cold joint. Every effort should be made to keep cold longitudinal construction joints spaced at least 50 to 75 feet.

CHAPTER 18

SEASONAL FROST CONDITIONS

18-1. General.

This chapter presents criteria and procedures for the design and construction of pavements placed on subgrade or base course materials subject to seasonal frost action. The most prevalent modes of distress in pavements and their causes are listed in table 18-1. The detrimental effects of frost action in subsurface materials are manifested by nonuniform heave of pavements during the winter and by loss of strength of affected soils during the ensuing thaw period. This is accompanied by a corresponding increase in damage accumulation and a more rapid rate of pavement deterioration during the period of weakening. Other related detrimental effects of frost and low temperatures are possible loss of

compaction, development of permanent roughness, restriction of drainage by the frozen strata, and cracking and deterioration of the pavement surface. Hazardous operating conditions, excessive maintenance, or pavement destruction may result. Except in cases where other criteria are specifically established, pavements should be designed so that there will be no interruption of traffic at any time due to differential heave or to reduction in load-supporting capacity. Pavements should also be designed so that the rate of deterioration during critical periods of thaw weakening and during cold periods causing low-temperature cracking will not be so high that the useful life of the pavements will be less than that assumed as the design objective.

Table 18-1. Modes of Distress in Pavements.

| <u>Distress mode</u> | <u>General cause</u> | <u>Specific causative factor</u> |
|--|---|---|
| Cracking | Traffic-load associated | Repeated loading (fatigue) Slippage (resulting from braking stresses) |
| | Non-traffic-associated | Thermal changes Moisture changes Shrinkage of underlying materials (reflection cracking, which may also be accelerated by traffic loading) |
| Distortion (may also lead to cracking) | Traffic-load associated | Rutting, or pumping and faulting (from repetitive loading) Plastic flow or creep (from single or comparatively few excessive loads) |
| | Non-traffic-associated | Differential heave Swelling of expansive clays in subgrade Frost action in subgrades or bases Differential settlement Permanent, from long-term consolidation in subgrade Transient, from reconsolidation after heave (may be accelerated by traffic) Curling of rigid slabs, from moisture and temperature differentials |
| Disintegration | May be advanced stage of cracking mode of distress or may result from detrimental effects of certain materials contained within the layered system or from abrasion by traffic. May also be triggered by freeze-thaw effects. | |

18-2. Definitions.

The following frost terms are used in this chapter.

a. *Frost, soil, and pavement terms.*

(1) Base or subbase course contains all granular unbound, or chemical- or bituminous-stabilized material between the pavement surfacing layer and the untreated, or chemical- or bituminous-stabilized subgrade.

(2) Bound base is a chemical- or bituminous-stabilized soil used in the base and subbase course, consisting of a mixture of mineral aggregates and/or soil with one or more commercial stabilizing additives. Bound base is characterized by a significant increase in compressive strength of the stabilized soil compared with the untreated soil. In frost areas bound base usually is placed directly beneath the

pavement surfacing layer where its high strength and low deformability make possible a reduction in the required thickness of the pavement surfacing layer or the total thickness of pavement and base, or both. If the stabilizing additive is portland cement, lime, or lime-cement-flyash (LCF), the term bound base is applicable only if the mixture meets the requirements for cement-stabilized, lime-stabilized, or LCF-stabilized soil set forth herein and in TM 5-822-4.

(3) Boulder heave is the progressive upward migration of a large stone present within the frost zone in a frost-susceptible subgrade or base course. This is caused by adhesion of the stone to the frozen soil surrounding it while the frozen soil is under-going frost heave; the stone will be kept from an equal, subsequent subsidence by soil that will have tumbled into the cavity formed beneath the stone. Boulders heaved toward the surface cause extreme pavement roughness and may eventually break through the surface, necessitating repair or reconstruction.

(4) Cumulative damage is the process by which each application of traffic load or each cycle of climatic change produces a certain irreversible damage to the pavement. When this is added to previous damage, the pavement deteriorates continuously under successive load applications or climatic cycles.

(5) Frost action is a general term for freezing and thawing of moisture in materials and the resultant effects on these materials and on structures of which they are a part, or with which they are in contact.

(6) Frost boil is the breaking of a small section of a highway or airfield pavement under traffic with ejection of soft, semi-liquid subgrade soil. This is caused by the melting of the segregated ice formed by the frost action. This type of failure is limited to pavements with extreme deficiencies of total thickness of pavement and base over frost-susceptible subgrades, or pavements having a highly frost-susceptible base course.

(7) Frost heave is the raising of a surface due to formation of ice in the underlying soil.

(8) Frost-melting period is an interval of the year when the ice in base, subbase, or subgrade materials is returning to a liquid state. It ends when all the ice in the ground has melted or when freezing is resumed. In some cases there may be only one frost-melting period, beginning during the general rise of air temperatures in the spring, but one or more significant frost-melting intervals often occur during a winter season.

(9) Frost-susceptible soil is soil in which significant detrimental ice segregation will occur when the requisite moisture and freezing conditions are present.

(10) Granular unbound base course is base course containing no agents that impart higher cohesion by cementing action. Mixtures of granular soil with portland cement, lime, or flyash, in which the chemical agents have merely altered certain properties of the soil such as plasticity and gradation without imparting significant strength increase, also are classified as granular unbound base. However, these must meet the requirements for cement-modified, lime-modified, or LCF-modified soil set forth in TM 5-822-4 and in this chapter, and they must also meet the base course composition requirements set forth below.

(11) Ice segregation is the growth of ice as distinct lenses, layers, veins and masses in soils, commonly but not always oriented normal to the direction of heat loss.

(12) Nonfrost-susceptible materials are cohesionless materials such as crushed rock, gravel, sand, slag, and cinders that do not experience significant detrimental ice segregation under normal freezing conditions. Nonfrost-susceptible materials also include cemented or otherwise stabilized materials that do not evidence detrimental ice segregation, loss of strength upon thawing, or freeze-thaw degradation.

(13) Pavement pumping is the ejection of water and soil through joints, cracks, and along edges of pavements caused by downward movements of sections of the pavement. This is actuated by the passage of heavy axle loads over the pavement after free water has accumulated beneath it.

(14) Period of weakening is an interval of the year that starts at the beginning of a frost-melting period and ends when the subgrade strength has returned to normal summer values, or when the subgrade has again become frozen.

b. Temperature terms.

(1) Average daily temperature is the average of the maximum and minimum temperatures for a day, or the average of several temperature readings taken at equal time intervals, generally hourly, during a day.

(2) Mean daily temperature is the mean of the average daily temperatures for a given day in each of several years.

(3) Degree-days are the Fahrenheit degree-days for any given day equal to the difference between the average daily air temperature and 32 degrees Fahrenheit. The degree-days are minus

when the average daily temperature is below 32 degrees Fahrenheit (freezing degree-days) and plus when above (thawing degree-days). Figure 18-1 shows curves obtained by plotting cumulative degree-days against time.

(4) Freezing index is the number of degree-days between the highest and lowest points on a curve of cumulative degree-days versus time for one freezing season. It is used as a measure of the combined duration and magnitude of below-freezing temperatures occurring during any given freezing season. The index determined for air temperature approximately 4.5 feet above the ground is commonly designated as the air freezing index, while that determined for temperatures immediately below a surface is known as the surface freezing index.

(5) Design freezing index is the average air freezing index of the three coldest winters in the

latest 30 years of record. If 30 years of record are not available, the air freezing index for the coldest winter in the latest 10-year period may be used. To avoid the necessity of adopting a new and only slightly different freezing index each year, the design freezing index at a site with continuing construction need not be changed more than once in 5 years unless the more recent temperature records indicate a significant change in thickness design requirements for frost. The design freezing index is illustrated in figure 18-1.

(6) Mean freezing index is the freezing index determined on the basis of mean temperatures. The period of record over which temperatures are averaged is usually a minimum of 10 years, preferably 30, and should be the latest available. The mean freezing index is illustrated in figure 18-1.

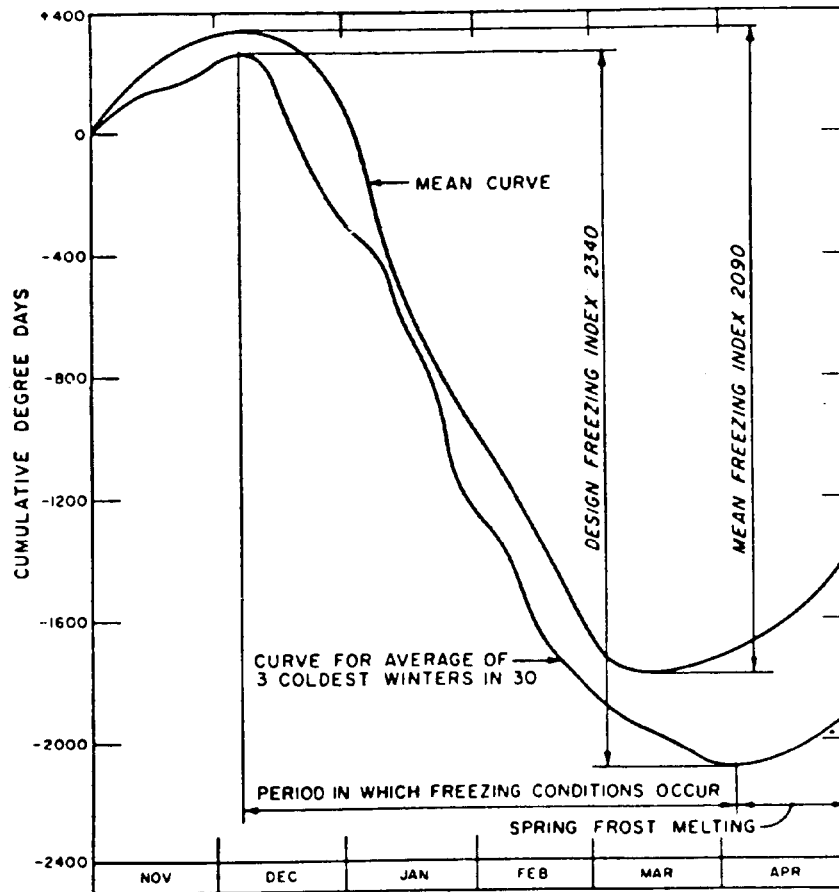

Figure 18-1. Determination of Freezing Index.

18-3. Frost-Susceptibility Classification.

For frost design purposes, soils are divided into eight groups as shown in table 18-2. The first four

groups are generally suitable for base course and subbase course materials, and any of the eight groups may be encountered as subgrade soils. Soils

are listed in approximate order of decreasing bearing capacity during periods of thaw. There is also a tendency for the order of the listing of groups to coincide with increasing order of susceptibility to frost heave, although the low coefficients of permeability of most clays restrict their heaving propen-

sity. The order of listing of subgroups under groups F3 and F4 does not necessarily indicate the order of susceptibility to frost heave of these subgroups. There is some overlapping of frost susceptibility between groups. Soils in group F4 are of especially high frost susceptibility.

Table 18-2. Frost Design Soil Classification.

| Frost group | Kind of soil | Percentage finer than 0.02 mm by weight | Typical soil types under Unified Soil Classification system |
|-------------|---|---|--|
| NFS* | (a) Gravels Crushed stone Crushed rock | 0-15 | GW, GP |
| PFS** | (b) Sands | 0-3 | SW, SP |
| | (a) Gravels Crushed stone Crushed rock | 1.5-3 | GW, GP |
| S1 | (b) Sands | 3-10 | SW, SP |
| | Gravelly soils | 3-6 | GW, GP, GW-GM, GP-GM |
| S2 | Sandy soils | 3-6 | SW, SP, SW-SM, SP-SM |
| F1 | Gravelly soils | 6 to 10 | GM, GW-GM, GP-GM |
| F2 | (a) Gravelly soils | 10 to 20 | GM, GW-GM, GP-GM |
| | (b) Sands | 6 to 15 | SM, SW-SM, SP-SM |
| F3 | (a) Gravelly soils | Over 20 | GM, GC |
| | (b) Sands, except very fine silty sands | Over 15 | SM, SC |
| F4 | (c) Clays, PI > 12 | -- | CL, CH |
| | (a) All silts | -- | ML, MH |
| | (b) Very fine silty sands | Over 15 | SM |
| | (c) Clays, PI > 12 | -- | CL, CL-ML |
| | (d) Varved clays and other fine-grained, banded sediments | -- | CL, CL-ML CL and ML; CL, ML, and SM; CL, CH, and ML; CL, CH, ML and SM |

*Non-frost-susceptible.

**Possibly frost-susceptible, but requires laboratory test to determine frost design soils classification.

a. *S1 and S2 groups.* The S1 group includes gravelly soils with very low to medium frost-susceptibility classifications that are considered suitable for subbase materials. They will generally exhibit less frost heave and higher strength after freeze-thaw cycles than similar F1 group subgrade Soils. The S2 group includes sandy soils with very low to medium frost-susceptibility classifications that are considered suitable for subbase materials. Due to their lower percentages of finer-than-0.02-millimeter grains than similar F2 groups subgrade

soils, they will generally exhibit less frost heave and higher strength after freeze-thaw cycles.

b. *F1 and F2 groups.* The F1 group is intended to include frost-susceptible gravelly soils that in the normal unfrozen condition have traffic performance characteristics of GM-, GW-GM-, and GP-GM-type materials with the noted percentage of fines. The F. group is intended to include frostsusceptible soils that in the normal unfrozen condition have traffic performance characteristics of GM-, GW-GM-, GP-GM-, SM-, SW-SM-, or SP- SM-type

materials with fines within the stated limits. Occasionally, GC or SC materials may occur within the F. group, although they will normally fall into the F3 category. The basis for division between the F1 and F. groups is that F1 materials may be expected to show higher bearing capacity than F. materials during thaw, even though both may have experienced equal ice segregation.

c. Varved clays. Valved clays consisting of alternating layers of silts and clays are likely to combine the undesirable properties of both silts and clays. These and other stratified fine-grained sediments may be hard to classify for frost design. Since such soils are likely to heave and soften more readily than homogeneous soils with equal average water contents, the classification of the material of highest frost susceptibility should be adopted for design. Usually, this will place the overall deposit in the F4 category.

d. Special conditions. Under special conditions the frost group classification adopted for design may be permitted to differ from that obtained by application of the above frost group definitions. This will, however, be subject to the specific approval of HQUSACE (CEMP-ET) or the appropriate Air Force Major Command if the difference is not greater than one frost group number and if complete justification for the variation is presented. Such justification may take into account special conditions of subgrade moisture or soil uniformity, in addition to soil gradation and plasticity, and should include data on performance of existing pavements near those proposed to be constructed.

18-4. Alternative Methods of Thickness Design.

The thickness design process is the determination of the required thickness for each layer of a pavement system and of the combined thickness of all layers above the subgrade. Its objective is determining the lowest-cost pavement system whose rate of deterioration under traffic loads and environmental conditions will be acceptably low. In seasonal frost areas the thickness design process must include the effects of frost action. Two methods are prescribed for determining the thickness design of a pavement that will have adequate resistance to distortion by frost heave and cracking and distortion under traffic loads as affected by seasonal variation of supporting capacity, including possible severe weakening during frost-melting periods.

a. Limited subgrade frost penetration method. The first method is directed specifically to the control of pavement distortion caused by frost heave. It requires a sufficient thickness of pavement,

base, and subbase to limit the penetration of frost into the frost-susceptible subgrade to an acceptable amount. Included also in this method is a design approach which determines the thickness of pavement, base, and subbase necessary to prevent the penetration of frost into the subgrade. Prevention of frost penetration into the subgrade is nearly always uneconomical and unnecessary, and will not be used to design pavements to serve conventional traffic, except when approved by HQUSACE (CEMP-ET) or the appropriate Air Force Major Command.

b. Reduced subgrade strength method. The second method does not seek to limit the penetration of frost into the subgrade, but it determines the thickness of pavement, base, and subbase that will adequately carry traffic loads over the design period of years, each of which includes one or more periods during which the subgrade supporting capacity is sharply reduced by frost melting. This approach relies on uniform subgrade conditions, adequate subgrade preparation techniques, and transitions for adequate control of pavement roughness resulting from differential frost heave.

18-5. Selection of Design Method.

In most cases the choice of the pavement design method will be made in favor of the one that gives the lower cost. Exceptions dictating the choice of the limited subgrade frost penetration method, even at higher cost, include pavements in locations where subgrade soils are so extremely variable (as, for example, in some glaciated areas) that the required subgrade preparation techniques could not be expected to provide sufficient protection against differential frost heave. In other cases special operational demands on the pavement might dictate unusually severe restrictions on tolerable pavement roughness, requiring that subgrade frost penetration be strictly limited or even prevented. If the use of limited subgrade frost penetration method is not required, tentative designs must be prepared by both methods for comparison of costs. Also, a tentative design must be prepared following the nonfrost-design criteria, since the thickness requirements under nonfrost-criteria must be met in addition to the frost design requirements.

18-6. Limited Subgrade Frost Penetration.

This method of design for seasonal frost conditions should be used where it requires less thickness than the reduced subgrade strength method. Its use is likely to be economical only in regions of low design freezing index.

a. Air freezing index. Air freezing index values

should be based on actual air temperatures obtained from the meteorological station closest to the construction site. This is desirable because differences in elevation or topographical position, or nearness to bodies of water, cities, or other sources of heat may cause considerable variation in air freezing indexes over short distances. These variations are of greater relative importance in areas of design freezing index of less than 1,000 degree Fahrenheit days (i.e. mean air freezing index of less than about 500 degree Fahrenheit days) than they are in colder climates. The daily maximum and minimum and mean monthly air temperature records for all stations that report to the U.S. National Weather Service are available from Weather Service Centers. One of these centers is generally located in each state. The mean air freezing index may be based on mean monthly air temperatures, but computation of values for the design freezing index may be limited to only the coldest years in the desired cycle. These years may be selected from the tabulation of average monthly temperatures for the nearest first-order weather station. (A local climatological data summary containing this tabulation for the period of record is published annually by the National Weather Service for each of the approximately 350 U.S. first-order stations.)

If the temperature record of the station closest to the construction site is not long enough to determine the mean or design freezing index values, the available data should be related, for the same period, to that of the nearest station or stations of adequate record. Site air freezing index values can then be computed based on this established relation and the indexes for the more distant station or stations.

b. Design freezing index. The design freezing index should be used in determining the combined thickness of pavement, base, and subbase required to limit subgrade frost penetration. As with any natural climatic phenomenon, winters that are colder than average occur with a frequency that decreases as the degree of departure from average becomes greater. A mean freezing index cannot be computed where temperatures in some of the winters do not fall below freezing. A design method has been adopted that uses the average air freezing index for the three coldest years in a 30-year period (or for the coldest winter in 10 years of record) as the design freezing index to determine the thickness of protection that will be provided. A distribution of design freezing index for North America is shown in figure 18-2 and is to be used as a guide only.

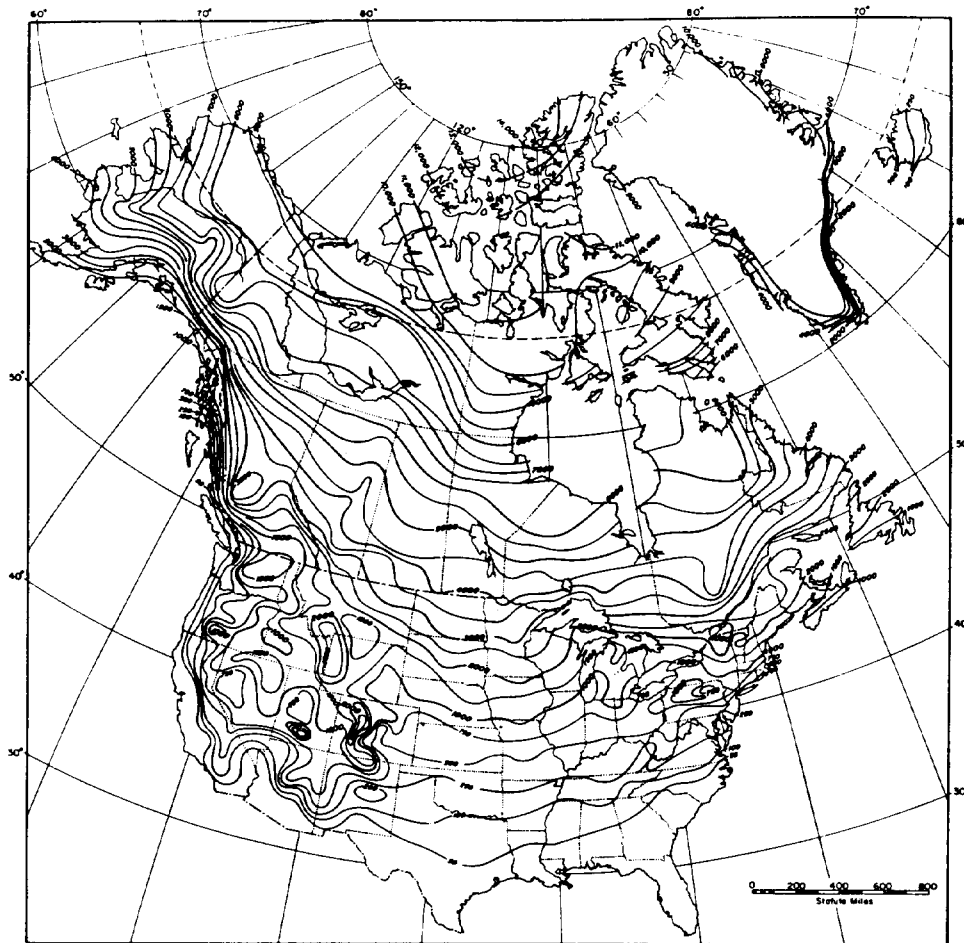

Figure 18-2. Distribution of Design Freezing Index for North America.

c. *Design method.* The design method permits a small amount of frost penetration into frost-susceptible subgrades for the design freezing index year. The procedure is described in the following subparagraphs.

(1) Estimate average moisture contents in the base course and subgrade at start of freezing period, and estimate the dry unit weight of base. The moisture content of the base is generally affected by the moisture content of the subgrade, drainage, precipitation, and depth to water table. As the base course may, in some cases, comprise successive layers containing substantially different fine contents, the average moisture content and dry unit weight should be weighted in proportion to the thickness of the various layers. Alternatively, if layers of bound base course and granular unbound base course are used in the pavement, the average may be assumed to be equal to the moisture content and dry unit weight of the material in the granular unbound base course.

(2) From figure 18-3, determine frost penetration depth (a). These frost penetration depths are based on modified Berggren formula and computational procedures outlined in TM 5-852-6. Frost penetration depths are measured from pavement surface. Depths are computed on a 12-inch rigid pavement kept free of snow and ice, and are good approximations for bituminous pavements over 6 to 9 inches of high-quality base. Computations also assume that all soil beneath pavements within depths of frost penetration are granular and non-frost susceptible. It was assumed in computations that all soil moisture freezes at 32 degrees Fahrenheit. Use straight line interpolation where necessary. For rigid pavements greater than 12 inches thick, deduct 10 degree-days for each inch of pavement exceeding 12 inches from the design freezing index before entering figure 18-3 to determine frost penetration depth (a). Then add extra concrete pavement thickness to the determined frost penetration.

(3) Compute thickness of unbound base C (fig 18-4) required for zero frost penetration into the subgrade as follows:

$$C=a-p$$

where

a=frost penetration depth

p=thickness of portland cement concrete or bituminous concrete

(4) Compute ratio $r = \frac{\text{water content of subgrade}}{\text{water content of base}}$

(5) Enter figure 18-4 with C as the abscissa and, at the applicable value of r, find on the left scale the design base thickness b that will result in the allowable subgrade frost penetration s shown on the right scale. If r is greater than 3.0 use 3.0

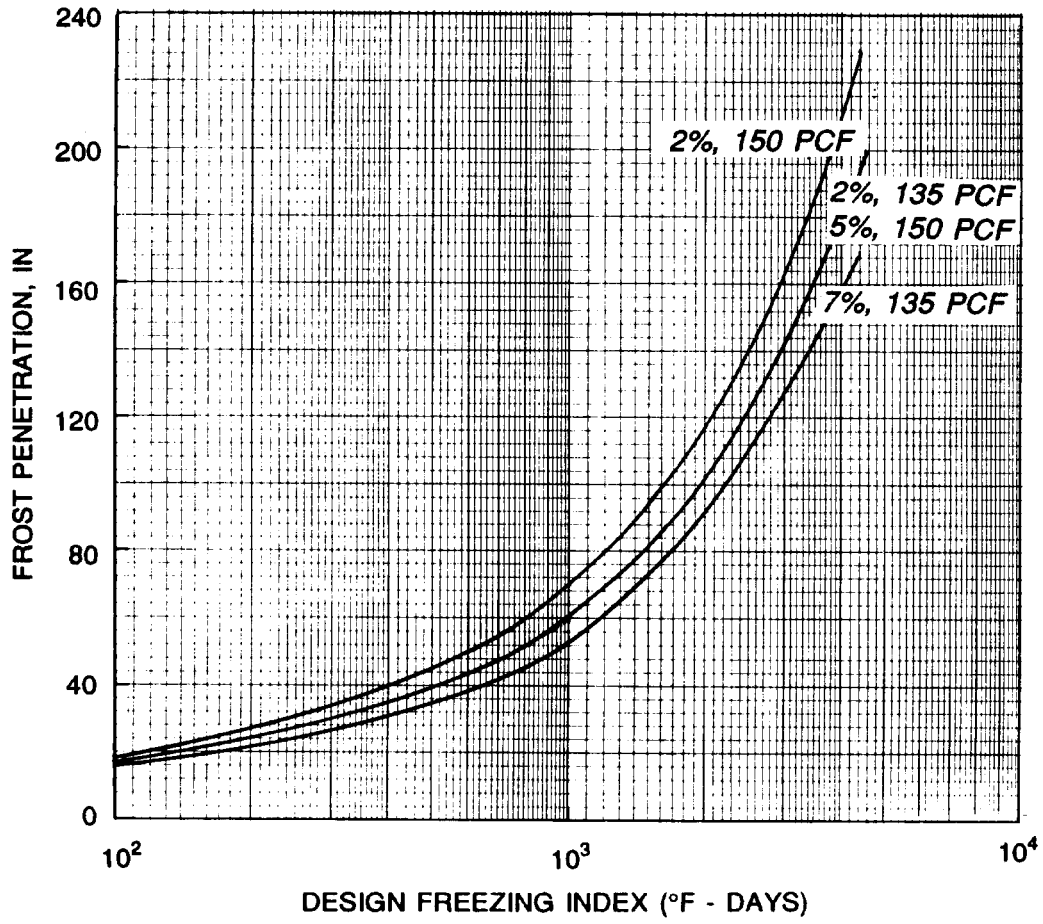

Figure 18-3. Frost Penetration Beneath Pavements. (Sheet 1 of 3)

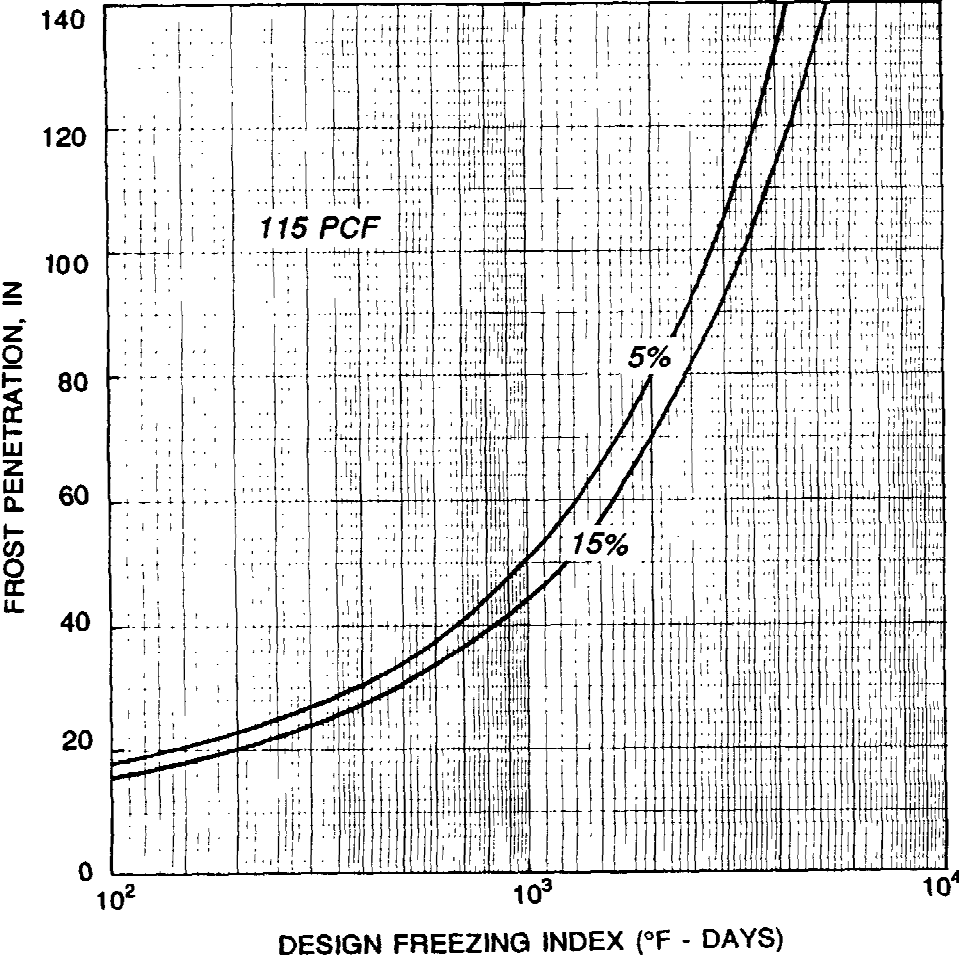

Figure 18-3. Frost Penetration Beneath Pavements. (Sheet 2 of 3)

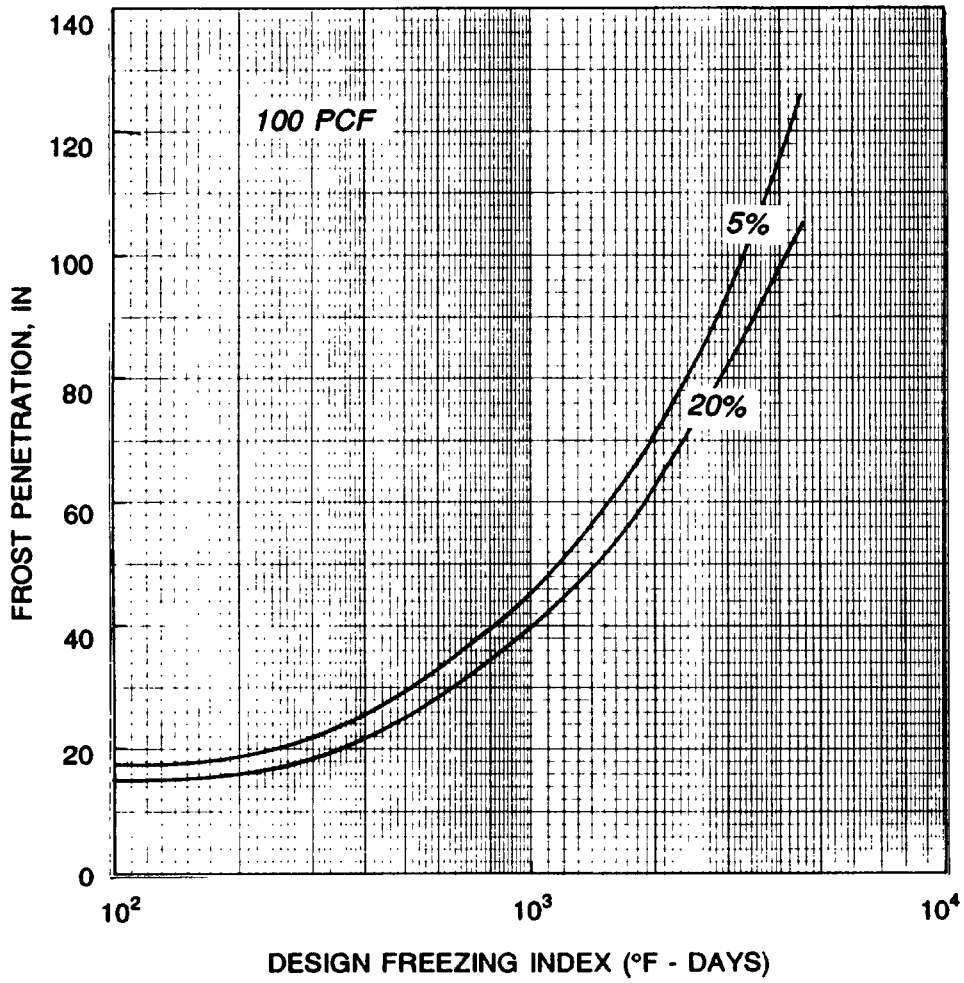

Figure 18-3. Frost Penetration Beneath Pavements. (Sheet 3 of 3)

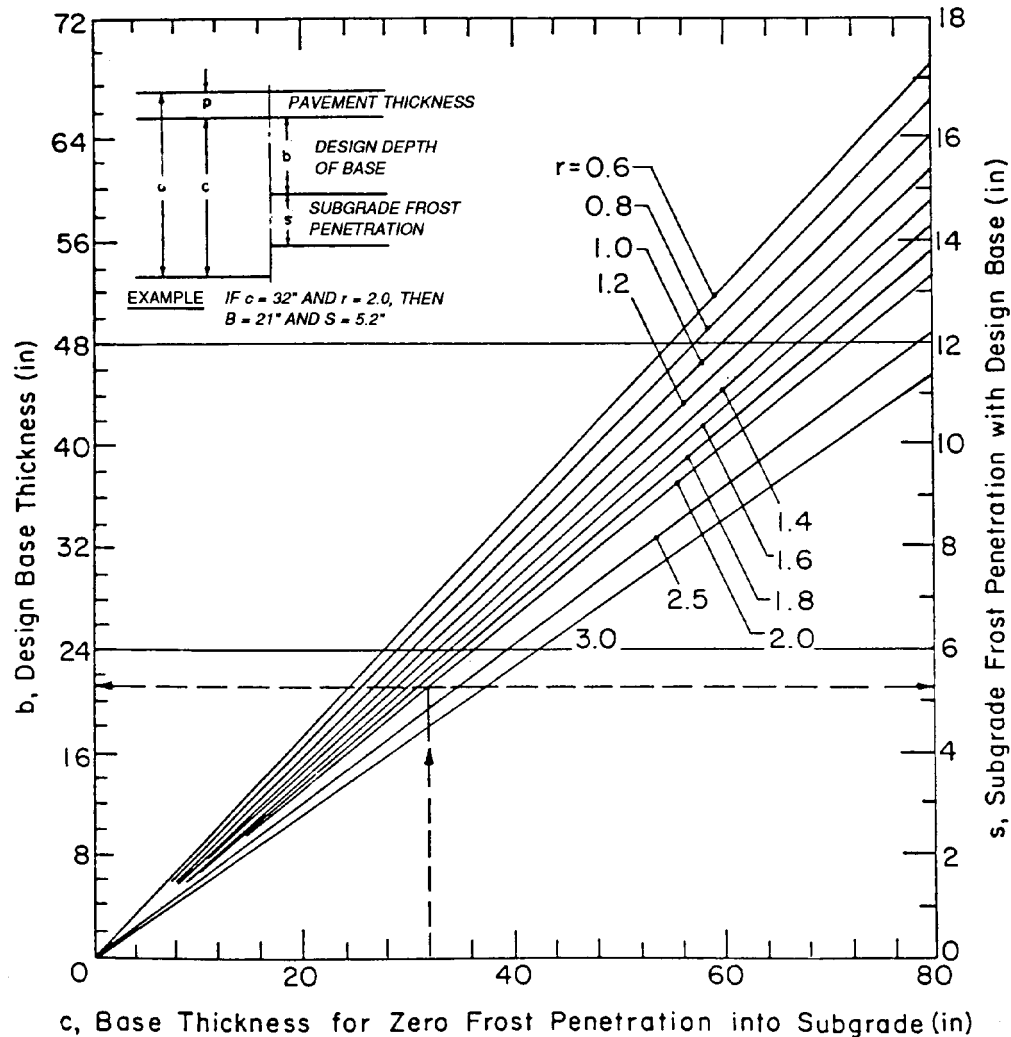

Figure 18-4. Design Depth of Nonfrost-Susceptible Base for Limited Subgrade Frost Penetration.

d. *Thickness.* The above procedure will result in a thickness of material between the frost-susceptible subgrade and the pavement so that for average field conditions subgrade frost penetration of the amount *s* should not cause excessive differential heave of the pavement surface during the design freezing index year.

e. *Controlling thickness.* If the combined thickness of pavement and base required by the non-frost criteria exceeds the thickness given by the limited subgrade frost penetration procedure of design, the greater thickness given by the nonfrost-criteria will be adopted as the design thickness.

f. *Effects of nonfrost criteria.* The base course composition requirements of this chapter should be rigorously followed. The design base thickness is the total thickness of filter layers, granular unbound base and subbase, and any bound base. For flexible pavements, the thickness of the asphalt surfacing

layer and of any bound base, as well as the CBR (California Bearing Ratio) requirements of each layer of granular unbound base, will be determined using nonfrost criteria. The thickness of rigid pavement slab will also be determined from nonfrost criteria.

18-7. Reduced Subgrade Strength.

Thickness design may also be based on the seasonally varying subgrade support that includes sharply reduced values during thawing of soils that have been affected by frost action. Excepting pavement projects that are located in regions of low design freezing index, this design procedure usually requires less thickness of pavement and base than that needed for limited subgrade frost penetration. The method may be used for both flexible and rigid pavements wherever the subgrade is reasonably uniform or can be made reasonably horizontally

uniform by the required techniques of subgrade preparation. This will prevent or minimize significant or objectionable differential heaving and resultant cracking of pavements. When the reduced subgrade strength method is used for F4 subgrade soils, unusually rigorous control of subgrade preparation must be required. When a thickness determined by the reduced subgrade strength procedure exceeds that determined for limited subgrade frost penetration, the latter smaller value shall be used, provided it is at least equal to the thickness required for nonfrost conditions. In situations where use of the reduced subgrade strength procedure might result in objectionable frost heave, but use of the greater thickness of base course indicated by the limited subgrade frost penetration design procedure is not considered necessary, intermediate design thickness may be used. However, these must be justified on the basis of frost heaving experience developed from existing pavements where climatic and soil conditions are comparable.

a. *Thickness of flexible pavements.* In the reduced subgrade strength procedure for design, the design curves herein (fig 8-1) should be used for road, street, and parking area design. The curves should not be entered with subgrade CBR values determined by tests or estimates, but instead with the applicable frost-area soil support index from table 18-3. Frost-area soil support indexes are used as if they were CBR values; the term CBR is not applied to them, however, because being weighted average values for an annual cycle, their value cannot be determined by CBR tests. The soil support index for S1 or S2 material meeting current specifications for base or subbase will be determined by conventional CBR tests in the unfrozen state.

Table 18-3. Frost-Area Soil Support Indexes for Subgrade Soils for Flexible Pavement Design.

| Frost group of subgrade soil | Frost-area soil support index |
|------------------------------|-------------------------------|
| F1 and S1..... | 9.0 |
| F2 and S2..... | 6.5 |
| F3 and F4..... | 3.5 |

(1) General field data and experience indicate that on the relatively narrow embankments of roads and streets, reduction in strength of subgrades during frost melting may be less in substantial fills than in cuts because of better drainage conditions and less intense ice segregation. If local

field data and experience show this to be the case, then a reduction in combined thickness of pavement and base for frost conditions of up to 10 percent may be permitted for substantial fills.

(2) Flexible pavement criteria for nonfrost design should also be used to determine the thickness of individual layers in the pavement system, and to ascertain whether it will be advantageous to include one or more layers of bound base in the system. The base course composition requirements set forth must be followed rigorously.

b. *Thickness of rigid pavements.* Where frost is expected to penetrate into a frost-susceptible subgrade beneath a rigid pavement, it is good practice to use a nonfrost-susceptible base course at least equal in thickness to the slab. Experience has shown, however, that rigid pavements with only a 4-inch base have performed well in cold environments with relatively uniform subgrade conditions. Accordingly, where subgrade soils can be made reasonably uniform by the required procedures of subgrade preparation, the minimum thickness of granular unbound base may be reduced to a minimum of 4 inches. The material shall meet the requirements set forth below for free-draining material as well as the criteria for filter under pavement slab. If it does not also meet the criteria for filter over subgrade, a second 4-inch layer meeting that criteria shall be provided.

(1) Additional granular unbound base course, giving a thickness greater than the minimum specified above, will improve pavement performance, giving a higher frost-area index of reaction on the surface of the unbound base (fig. 18-5) and permitting a pavement slab of less thickness. Bound base also has significant structural value, and may be used to effect a further reduction in the required thickness of rigid pavement slab. Criteria for determining the required thickness of rigid pavement slabs in combination with a bound base course are contained in chapter 12. The requirements for granular unbound base as drainage and filter layers will still be applicable.

(2) The thickness of concrete pavement will be determined in accordance with chapter 12, using the frost-area index of reaction determined from figure 18-5. This figure shows the equivalent weighted average index of reaction values for an annual cycle that includes a period of thaw-weakening in relation to the thickness base. Frost-area indexes of reaction are used as if they were moduli of reaction, k , and have the same units. The term modulus of reaction is not applied to them because being weighted average values for an annual cycle,

they cannot be determined by a plate-bearing test. If the modulus of reaction, k , determined from tests on the equivalent base course and subgrade, but

without frost melting, is numerically smaller than the index of reaction obtained from figure 18-5, the test value shall govern the design.

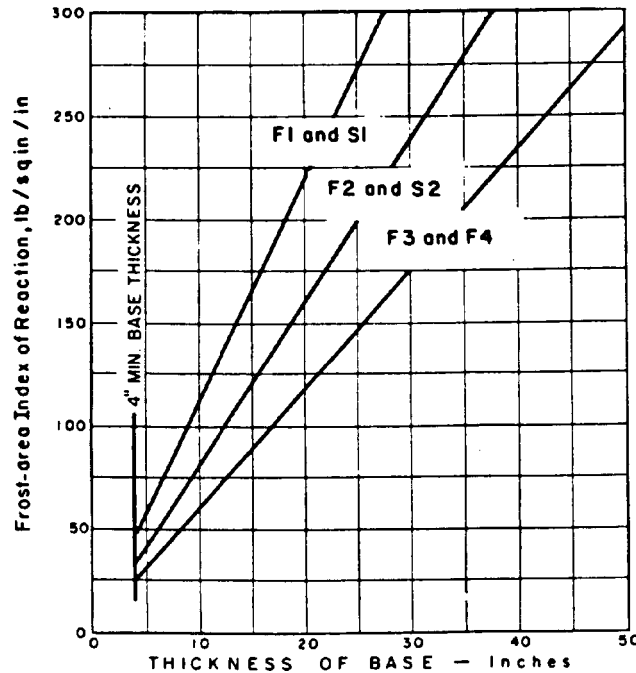

Figure 18-5. Frost-Area Index of Reaction for Design of Rigid Roads, Streets, and Open Storage Areas.

18-8. Use of State Highway Requirements.

To provide further flexibility in design options, and to exploit economical local materials and related experience, state highway requirements may be used for pavements with a design index less than 4. The decision to use local state highway requirements will be based on demonstrated satisfactory performance of pavements in that state as determined by observation and experience. This should give reasonable assurance that the life cycle cost resulting from use of state highway requirements is comparable to that from use of Army and Air Force criteria and procedures. If state requirements are used, the entire pavement should conform in every detail to the applicable state criteria.

18-9. Free-Draining Material Directly Beneath Bound Base or Surfacing Layer.

Base courses may consist of either granular unbound materials or bound base materials or a combination of the two. However, a cement- or lime-bound base should not be placed directly beneath bituminous pavement unless approved by HQU-SACE (CEMP-ET) or the appropriate Air Force

Major Command. Also, an unbound course will not be placed between two relatively impervious bound layers. If the combined thickness, in inches, of pavement and contiguous bound base courses is less than 0.09 multiplied by the design air freezing index (this calculation limits the design freezing index at the bottom of the bound base to about 20 degree-days), not less than 4 inches of free-draining material shall be placed directly beneath the lower layer of bound base or, if there is no bound base, directly beneath the pavement slab or surface course. The free-draining material shall contain 2.0 percent or less, by weight, of grains that can pass the no. 200 sieve, and to meet this requirement, it probably will have to be screened and washed. If the structural criteria for design of the pavement do not require granular unbound base other than the 4 inches of free-draining material, then the material in the 4-inch layer must be checked for conformance with the filter requirements below. If it fails the test for conformance, an additional layer meeting those requirements must be provided. When using a drainage layer, the drainage layer must extend to an open ditch or subdrains must be used. Pavement drainage is discussed in TM 5-820-2.

18-14. Stabilization with Lime and with LCF.

a. Bound base. Soils containing only lime as the stabilizer are generally unsuitable for use as base course layers in the upper layers of pavement systems in frost areas. Lime, cement, and a pozzolanic material such as flyash may be used in some cases to produce a cemented material of high quality that is suitable for upper base course and that has adequate durability and resistance to freeze-thaw action. In frost areas, LCF mixture design will be based on the procedures set forth in TM 5-822-4 with the additional requirement that the mixture, after freeze-thaw testing as set forth below, should meet the weight-loss criteria specified in TM 5-822-4 for cement-stabilized soil. The procedures in ASTM D 560 should be followed for freeze-thaw testing, except that the specimens should be compacted in a 6-inch diameter mold in five layers with a 10-pound hammer having an 18-inch drop, and that the preparation and curing of the specimens should follow the procedures indicated in TM 5-822-4 for unconfined compression tests on lime-stabilized soil.

b. Lime-stabilized soil. If it is economical to use lime-stabilized or lime-modified soil in lower layers of a pavement system, a mixture of adequate durability and resistance to frost action is still necessary. In addition to the requirements for mixture design of lime-stabilized and lime-modified subbase and subgrade materials set forth in TM 5-822-4, cured specimens should be subjected to the 12 freeze-thaw cycles in ASTM D 560 (but omitting wire-brushing) or other applicable freeze-thaw procedures. This should be followed by determination of frost-design soil classification by means of standard laboratory freezing tests. The USACECRL in Hanover, NH, has the capability to perform these tests. For lime-stabilized or lime-modified soil used in lower layers of the base course, the frost susceptibility, determined after freeze-thaw cycling, should meet the requirements set forth for base course in chapter 5 of this manual. If lime-stabilized or lime-modified soil is used as subgrade, its frost susceptibility, determined after freeze-thawing cycling, should be used as the basis of the pavement thickness design if the reduced subgrade strength design method is applied.

18-15. Stabilization with Portland Cement.

Cement-stabilized soil meeting the requirements set forth in TM 5-822-4, including freeze-thaw effects tested under ASTM D 560, may be used in frost areas as base course or as stabilized subgrade. Cement-modified soil conforming with the requirements in TM 5-822-4 also may be used in

frost areas. However, in addition to the procedures for mixture design specified in TM 5-822-4, cured specimens of cement-modified soil should be subjected to the 12 freeze-thaw cycles in ASTM D 560 (but omitting wire-brushing) or other applicable freeze-thaw procedures. This should be followed by determination of frost design soil classification by means of standard laboratory freezing tests. The USACECRL in Hanover, NH, has the capability to perform these tests. For cement-modified soil used in the base course, the frost susceptibility, determined after freeze-thaw cycling, should meet the requirements set forth for base course in chapter 5 of this manual. If cement-modified soil is used as subgrade, its frost susceptibility, determined after freeze-thaw cycling, should be used as the basis of the pavement thickness design if the reduced subgrade design method is applied.

18-16. Stabilization With Bitumen.

Many different types of soils and aggregates can be successfully stabilized to produce a high-quality bound base with a variety of types of bituminous material. In frost areas the use of tar as a binder should be avoided because of its high temperature susceptibility. Asphalts are affected to a lesser extent by temperature changes, but a grade of asphalt suitable to the prevailing climatic conditions should be selected. Excepting these special conditions affecting the suitability of particular types of bitumen, the procedures for mixture design set forth in TM 5-822-4 and TM 5-822-8 usually will ensure that the asphalt-stabilized base will have adequate durability and resistance to moisture and freeze-thaw cycles.

18-17. Subgrade Requirements.

It is a basic requirement for all pavements constructed in frost areas, that subgrades in which freezing will occur, shall be prepared to achieve uniformity of soil conditions by mixing stratified soils, eliminating isolated pockets of soil of higher or lower frost susceptibility, and blending the various types of soils into a single, relatively homogeneous mass. It is not intended to eliminate from the subgrade those soils in which detrimental frost action will occur, but to produce a subgrade of uniform frost susceptibility and thus create conditions tending to make both surface heave and subgrade thaw-weakening as uniform as possible over the paved area. In fill sections the least frost-susceptible soils shall be placed in the upper portion of the subgrade by temporarily stockpiling the better materials, cross-hauling, and selective grading. If the upper layers of fill contain frost-susceptible soils,

and the completed fill section shall be subjected to the subgrade preparation procedures required for cut sections. In cut sections the subgrade shall be scarified and excavated to a prescribed depth, and the excavated material shall be windrowed and bladed successively until thoroughly blended, then relaid and compacted. The depth of subgrade preparation, measured downward from the top of the subgrade, shall be the lesser of 24 inches; two-thirds of the frost penetration for class A, B, and C roads, streets, and open storage areas or one-half of the frost penetration for roads, streets, and open storage areas of class D, E, and F less the actual combined thickness of pavement, base course, and subbase course. The prepared subgrade must meet the designated compaction requirements for non-frost areas. The construction inspection personnel should be alert to verify that the processing of the subgrade will yield uniform soil conditions throughout the section. To achieve uniformity in some cases, it will be necessary to remove highly frost susceptible soils or soils of low frost susceptibility. In that case the pockets of soil to be removed should be excavated to the full depth of frost penetration and replaced with material surrounding the frost-susceptible soil being removed.

a. Exceptions conditions. Exceptions to the basic requirement for subgrade preparation are subgrades known to be nonfrost susceptible to the depth prescribed for subgrade preparation and known to contain no frost-susceptible layers or lenses, as demonstrated and verified by extensive and thorough subsurface investigations and by the performance of nearby existing pavements. Also, fine-grained subgrades containing moisture well in excess of the optimum for compaction, with no feasible means of drainage nor of otherwise reducing the moisture content, and which consequently it is not feasible to scarify and recompact, are also exceptions.

b. Treatment of wet fine-grained subgrades. If wet fine-grained subgrades exist at the site, it will be necessary to achieve frost protection with fill

material. This may be done by raising the grade by an amount equal to the depth of subgrade preparation that otherwise would be prescribed, or by undercutting and replacing the wet fine-grained subgrade to that same depth. In either case the fill or backfill material may be nonfrost-susceptible material or frost-susceptible material meeting specified requirements. If the fill or backfill material is frost susceptible, it should be subjected to the same subgrade preparation procedures prescribed above.

c. Cobbles or boulders. A critical condition requiring the attention of inspection personnel is the presence of cobbles or boulders in the subgrades. All stones larger than about 6 inches in diameter should be removed from fill materials for the full depth of frost penetration, either at the source or as the material is spread in the embankments. Any such large stones exposed during the sub-grade preparation work also must be removed, down to the full depth to which subgrade preparation is required. Failure to remove stones or large roots can result in increasingly severe pavement roughness as the stones or roots are heaved gradually upward toward the pavement surface. They eventually break through the surface in extreme cases, necessitating complete reconstruction.

d. Changes in soil conditions. Abrupt changes in soil conditions must not be permitted. Where the subgrade changes from a cut to a fill section, a wedge of subgrade soil in the cut section with the dimensions shown in figure 18-6 should be removed and replaced with fill material. Tapered transitions also are needed at culverts beneath paved areas, but in such cases the transition material should be clean, nonfrost-susceptible granular fill. Other under-pavement pipes should be similarly treated, and perforated-pipe underdrains should be constructed. These and any other discontinuities in subgrade conditions require the most careful attention of construction inspection personnel, as failure to enforce strict compliance with the requirements for transitions may result in serious pavement distress.

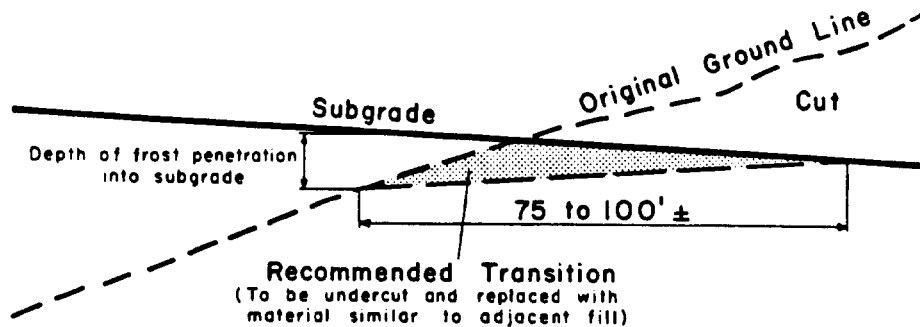

Figure 18-6. Tapered Transition Used Where Embankment Material Differs from Natural Subgrade in Cut.

e. *Wet areas.* Careful attention should be given to wet areas in the subgrade, and special drainage measures should be installed as required. The need for such measures arises most frequently in road construction, where it may be necessary to provide intercepting drains to prevent infiltration into the subgrade from higher ground adjacent to the road.

f. *Rock excavation.* In areas where rock excavation is required, the character of the rock and seepage conditions should be considered. In any case, the excavations should be made so that positive transverse drainage is provided, and no pockets are left on the rock surface that will permit ponding of water within the depth of freezing. The irregular groundwater availability created by such conditions may result in markedly irregular heaving under freezing conditions. It may be necessary to fill drainage pockets with lean concrete. At intersections of fills with rock cuts, the tapered transitions mentioned above (fig 18-6) are essential. Rock subgrades where large quantities of seepage are involved should be blanketed with a highly pervious material to permit the escape of water. Frequently, the fractures and joints in the rock contain frost-susceptible soils. These materials should be cleaned out of the joints to the depth of frost penetration and replaced with nonfrost susceptible material. If this is impractical, it may be necessary to remove the rock to the full depth of frost penetration.

g. *Rock subgrades.* An alternative method of treatment of rock subgrades, in-place fragmentation, has been used effectively in road construction. Blast holes 3 to 6 feet deep are commonly used. They are spaced suitably for achieving thorough fragmentation of the rock to permit effective drainage of water through the shattered rock and out of the zone of freezing in the subgrade. A tapered transition should be provided between the shattered rock cut and the adjacent fill.

18-18. Other Measures to Reduce Heave.

Other possible measures to reduce the effects of heave are the use of insulation (appendix D) to control depth of frost penetration and the use of steel reinforcement to improve the continuity of rigid pavements that may become distorted by frost heave. Reinforcement will not reduce heave nor prevent the cracking resulting from it, but it will help to hold cracks tightly closed and thus reduce pumping through these cracks. Transitions between cut and fill and culverts and drains change in character or stratification of subgrade soils. Subgrade preparation and boulder removal should also receive special attention in field construction control.

18-19. Pavement Cracking Associated with Frost Heave.

One of the most detrimental effects of frost action on a pavement is surface distortion as the result of differential frost heave or differential loss of strength. These may also lead to random cracking. Deterioration and spalling of the edges of working cracks are causes of uneven surface conditions and sources of debris. Cracking may be reduced by control of such elements as base composition, uniformity and thickness, slab dimensions, subbase and subgrade materials, uniformity of subsurface moisture conditions, and, in special situations, by use of reinforcement and by limitation of pavement type. The importance of uniformity cannot be overemphasized. Where unavoidable discontinuities in subgrade conditions exist, gradual transitions are essential.

18-20. Control of Subgrade and Base Course Construction.

Personnel responsible for field control of pavement construction in areas of seasonal freezing should give specific consideration to conditions and mate-

rials that will result in detrimental frost action. The contract plans and specifications should require the subgrade preparation work established for nonfrost areas in this manual in frost areas. They also should provide for special treatments such as removal of unsuitable materials encountered with sufficient information included to identify those materials and specify necessary corrective measures. However, construction operations quite frequently expose frost-susceptible conditions at isolated locations of a degree and character not revealed by even the most thorough subsurface exploration program. It is essential, therefore, that personnel assigned to field construction control be alert to recognize situations that require special treatment, whether or not anticipated by the design agency. They must also be aware of their responsibility for such recognition.

18-21. Base Course Construction.

Where the available base course materials are well within the limiting percentages of fine material set forth above, the base course construction control should be in accordance with normal practice. In instances where the material selected for use in the top 50 percent of the total thickness of granular unbound base is borderline with respect to percentage of fine material passing the no. 200 sieve, or is of borderline frost susceptibility (usually materials having 1 1/2 to 3 percent of grains finer than 0.02 millimeters by weight), frequent gradation checks should be made to ensure that the materials meet the design criteria. If it is necessary for the contractor to be selective in the pit in order to obtain suitable materials, his operations should be inspected at the pit. It is more feasible to reject unsuitable materials at the source when large volumes of base course are being placed. It may be desirable to stipulate thorough mixing at the pit and, if necessary, stockpiling, mixing in windrows, and spreading the material in compacted thin lifts in order to ensure uniformity. Complete surface stripping of pits should be enforced to prevent mixing of detrimental fine soil particles or lumps in the base material.

a. Gradation of base course materials. The gradation of base course materials after compaction should be determined frequently, particularly at the start of the job, to learn whether or not fines are being manufactured in the base under the passage of the compaction equipment. For base course materials exhibiting serious degradation characteristics, a test embankment may be needed to study the formation of fines by the proposed compaction process. Mixing of base course materials with frost-

susceptible subgrade soils should be avoided by making certain that the subgrade is properly graded and compacted prior to placement of base course, by ensuring that the first layer of base course filters out subgrade fines under traffic, and by eliminating the kneading caused by over-compaction or insufficient thickness of the first layer of base course. Excessive rutting tends to cause mixing of subgrade and base materials. This can be greatly minimized by frequent rerouting of material-hauling equipment.

b. Visual inspection. After completion of each layer of base course, a careful visual inspection should be made before permitting additional material placement to ensure that areas with high percentages of fines are not present. In many instances these areas may be recognized both by examination of the materials and by observation of their action under compaction equipment, particularly when the materials are wet. The materials in any areas that do not meet the requirements of the specifications, which will reflect the requirements of this manual, should be removed and replaced with suitable material. A leveling course of fine-grained material should not be used as a construction expedient to choke open-graded base courses, to establish fine grade, or to prevent overrun of concrete. Since the base course receives high stresses from traffic, this prohibition is essential to minimize weakening during the frost-melting period. Action should be taken to vary the base course thickness so as to provide transition, when this is necessary, to avoid abrupt changes in pavement supporting conditions.

18-22. Compaction.

Subgrade, subbase, and base course materials must meet the applicable compaction requirements for nonfrost materials.

18-23. Use of Insulation Materials in Pavements.

The use of synthetic insulating material within a pavement cross section must have the written approval of HQUSACE (CEMP-ET) or the appropriate Air Force Major Command, which can also provide advice and assistance in regard to the structural analysis. Criteria for design of pavements containing insulating layers are contained in appendix D.

18-24. Design Example-Heavily Trafficked Road.

Design flexible and rigid pavement for the following conditions-

- a. Class B (rolling terrain within the "built-up area")*
- b. Category III*

TM 5-822-5/AFM 88-7, Chap. 1

c. *Design Index.* 4 (from TM 5-822-2/AFM 88-7, Chap 5)

d. *Design Freezing Index.* 700 degree-days

e. *Subgrade Material.*

Uniform sandy clay, CL

Plasticity index, 18

Frost group, F3

Water content, 20 percent (average)

Normal-period CBR, 10

Normal-period modulus of subgrade reaction

$k=200$ psi/inch on subgrade and 325 psi/

inch on 22 inches of base course.

f. *Base course material.*

Crushed gravel (GW), normal-period CBR = 80, 30 percent passing no.10 sieve, 1 percent passing no.200 sieve.

g. *Subbase course material.*

Coarse to fine silty sand (SP-SM), normal-period CBR=20,

11 percent passing no. 200 sieve, 6 percent finer than 0.02 millimeters, frost classification 52, meets filter criteria for material in contact with subgrade.

h. *Average dry unit weight (good quality base and subbase).* 135 pounds per cubic feet

i. *Average water content after drainage (good quality base and subbase).* 5 percent

j. *Highest groundwater.* About 4 feet below surface of subgrade

k. *Concrete flexural strength.* 650 psi

l. *Flexible pavement design by limited subgrade frost penetration method.* From figure 18-3, the combined thickness a of pavement and base to prevent freezing of the subgrade in the design freezing index year is 45 inches. According to criteria in chapter 8, the minimum pavement thickness is 2.5 inches over a CBR = 80 base course that must be at least 4 inches thick. The base thickness for zero frost penetration is 42.5 inches (45-2.5). The ratio of subgrade to base water content is $r = 20/5=4$. Since this is a highway pavement, the maximum allowable r of 3 is used in figure 18-4 to obtain the required thickness of base b of 24 inches, which would allow about 6 inches of frost penetration into the subgrade in the design year. Subgrade preparation would not be required since the combined thickness of pavement and base is more than one-half the thickness required for complete

protection.

m. *Flexible pavement design by reduced subgrade strength method.* From the REDUCED SUB-GRADE STRENGTH section, the frost-area soil support index is 3.5, which, from the design curve (fig 8-1), yields a required combined thickness of pavement and base of 20 inches. Since this is less than the 26-inch thickness (2.0 + 24) required by the limited subgrade frost penetration method, the 20-inch thickness would be used. The pavement structure could be composed of 2 inches of AC, 12 inches of crushed gravel (since the crushed gravel contains only 1 percent passing the no.200 sieve, it also serves as the free-draining layer directly beneath the pavement), and 6 inches of silty sand subbase material. Subgrade preparation would be required to a depth of $\frac{1}{2} \times 45 - 20 = 2\frac{1}{2}$ inches.

n. *Rigid pavement design by limited subgrade frost penetration method.* From figure 12-1, the required pavement thickness p , based on the normal-period $k = 325$ psi per inch, the concrete flexural strength of 650 psi and the design index of 4, is 5.8 inches (use 6 inch minimum). From figure 18-3, the combined thickness of pavement and base for zero frost penetration is 45 inches, equivalent to that for the flexible pavement. By use of $r = 3$ and a thickness of base for zero frost penetration of 39 inches (45-6) in figure 18-3, the required thickness of base b is 22 inches, which would allow about 5.5 inches of frost penetration into the subgrade in the design year. No subgrade preparation would be required.

o. *Rigid pavement design by the reduced subgrade strength method.* Since frost heave has not been a major problem, a minimum of 4 inches of the free-draining base course material could be used, plus 4 inches of the subbase that will serve as a filter material on the subgrade. For this case (8 inches of base and subbase) the frost-area index of reaction would be 50 psi per inch (fig. 18-5), requiring a pavement slab $7\frac{1}{2}$ inches thick. Sub-grade preparation to a depth of $\frac{1}{2} \times 45 - 15\frac{1}{2} = 7.0$ inches would be required.

p. *Alternative designs.* Other designs using stabilized layers, including ABC pavements, should be investigated to determine whether they are more economical than the designs presented above.

APPENDIX A

REFERENCES

Government Publications

Department of Defense

| | |
|------------------------------------|---|
| Military Standards, MIL-STD-619 | Engineering Soil Classification and Its Application |
| MIL-STD-621A | Test Method for Pavement Subgrade, Subbase, and Base-Course Materials |
| Military Specifications MIL-R-3472 | Roof-Coating, Asphalt-Base Emulsion |

Departments of the Army and the Air Force

| | |
|----------------------------------|--|
| TM 5-809-12/AFM 88-3, | Concrete Floor Slabs on Grade Subjected to Heavy Loads Chap. 15 |
| TM 5-818-1 | Procedures for Foundation Design of Buildings and Other Structures (Except Hydraulic Structures) |
| TM 5-818-7 | Foundations in Expansive Soils |
| TM 5-822-4 | Soil Stabilization for Pavements |
| TM 5-852-3 | Arctic and Subarctic Construction-Runway and Road Design |
| TM 5-820-2/AFM 88-5, Chap. 2 | Drainage and Erosion Control, Subsurface Drainage Facilities for Airfield Pavements |
| TM 5-822-2/AFM 88-7, Chap. 5 | General Provisions and Geometric Design for Roads, Streets, Walks, and Open Storage Areas |
| TM 5-822-7 | Standard Practice for Concrete Pavements |
| TM 5-822-8 | Bituminous Pavements Standard Practice |
| TM 5-825-2 | Flexible Pavement Design for Airfields |
| TM 5-826-2/AFM 88-24, Chap. 2 | Flexible Airfield Pavement Evaluation |
| TM 5-826-6/AFR 93-5 | Procedures for US Army and US Air Force Airfield Pavement Condition Surveys |
| TM 5-830-3 | Dust Control for Roads, Airfields, and Adjacent Areas |
| TM 5-852-6 | Arctic and Subarctic Construction, Calculation Methods for Determination of Depths of Freeze and Thaw in Soils |

Department of the Army, Waterways Experiment Station, Corps of Engineers, 3909 Halls Ferry Road, Vicksburg, MS 39180-6199

| | |
|------------|---|
| CRD-C 21 | Method of Test for Modulus of Elasticity in Flexure |
| CRD-C 527 | Joint Sealant, Cold Applied, Non-Jet Fuel-Resistant for Rigid and Flexible Pavement |
| TR S-75-10 | Development of a Structural Design Procedure for All-Bituminous Concrete Pavements for Military Roads |

General Services Administration

| | |
|-----------------------------------|--|
| Federal Specifications, SS-S-200E | Sealants, Joint, Two-Component, Jet-Blast-Resistant, Cold Applied, for Portland Cement Concrete Pavement |
| SS-S-1401C | Sealant, Joint, Non-Jet-Fuel-Resistant, Hot-Applied, for Portland Cement and Asphalt Concrete Pavements |

TM 5-822-5/AFM 88-7, Chap. 1

SS-S-1614A Sealant, Joint, Jet-Fuel-Resistant, Hot-Applied, for Portland Cement and Tar Concrete Pavements

Nongovernment Publications

American Society of Civil Engineers (ASCE)
385 East 47th Street, New York, NY 10017

"New Formulas for Stresses in Concrete Pavements for Airfields" *ASCE TRANSACTIONS*, 1948.

American Society for Testing and Materials (ASTM), 1916 Race St., Philadelphia, PA 19103

- | | |
|-----------|--|
| A 82-79 | Cold-Drawn Steel Wire for Concrete Reinforcement |
| A 184-79 | Fabricated Deformed Steel Bar Mats for Concrete Reinforcement |
| A 185-79 | Welded Steel Wire Fabric for Concrete Reinforcement |
| A 615-82 | Deformed and Plain Billet-Steel Bars for Concrete Reinforcement |
| A 616-82 | Rail-Steel Deformed and Plain Bars for Concrete Reinforcement |
| A 617-82 | Axle-Steel Deformed and Plain Bars for Concrete Reinforcement |
| C 78-84 | Flexural Strength of Concrete (Using Simple Beam with Third-Point Loading) |
| D 560-82 | Freezing and Thawing Tests of Compacted Soil-Cement Mixtures |
| D 1557-78 | Moisture-Density Relations of Soils and Soil Aggregate Mixtures Using 10-pound Rammer and 18-inch Drop |
| D 1633-84 | Compressive Strength of Molded Soil-Cement Cylinders |
| D 2487-85 | Classification of Soils for Engineering Purposes |
| D 2628-81 | Preformed Polychloroprene Elastomeric Joint Seals for Concrete Pavements |
| D 2835-76 | Lubricant for Installation of Preformed Compression Seals in Concrete Pavements |

APPENDIX B

DETERMINATION OF FLEXURAL STRENGTH AND MODULUS OF ELASTICITY OF BITUMINOUS CONCRETE

B-1. Purpose. This appendix describes procedures for preparation and testing of bituminous concrete to determine flexural strength and modulus of elasticity. The procedures are an adaptation of tests conducted on portland cement concrete specimens.

B-2. Applicable Standards. The standard applicable to this procedure is ASTM C 78.

B-3. Apparatus. Apparatuses required are a testing machine capable of applying repetitive loadings for compaction of beam specimens 6 by 6 by 21 inches to the design density (an Instron electro-mechanical testing machine meets this requirement); a steel mold, suitably reinforced to withstand compaction of specimens without distortion; two linear variable differential transformers (LVDT's); a 5,000-pound load cell; an X-Y recorder; and a testing machine for load applications conforming to ASTM C 78 (a Baldwin or Tinius Olsen hydraulic testing machine is suitable for this purpose).

B-4. Materials. Sufficient aggregate and bitumen meeting applicable specifications to produce six 6- by 6- by 21-inch test specimens are required. In the event the proportions of aggregate and bitumen, bitumen content, and density of compacted specimens are not known, additional materials will be required to conduct conventional Marshall tests to develop the needed mix design data.

B-5. Sample Preparation.

a. Prepare in a laboratory mixer four portions of paving mixture for one 6- by 6- by 21-inch beam test specimen consisting of aggregate and bitumen in the proportions indicated for optimum bitumen content. The total quantity of paving mixture should be such that when compacted to a uniform 6- by 6- inch cross section, the density of the beam will be as specified from previous laboratory mix design tests or other sources. The temperature of the paving mixture at the time of mixing should be such that subsequent compaction can be accomplished at 250 ± 5 degrees Fahrenheit. Place two of the four portions in the 6- by 6- by 21-inch reinforced steel mold and compact to a 3-inch thickness with a 6- by 6-inch foot attached to the repetitive loading machine. Shift the mold between load applications to distribute the compaction effort uniformly. Add the remaining two portions and continue

compaction until the paving mixture is compacted to a 6- by 6-inch cross section. After compaction and while the mixture is still hot, place a 6- by 21-inch steel plate on the surface of the paving mixture and apply a leveling load of 2,000 pounds to the plate for 30 minutes. Prepare six beam test specimens in the manner described.

b. After cooling, remove the beams from the molds and rotate 90 degrees so that the smooth, parallel sides will become the top and bottom. Cement and L-shaped metal tab with quick-setting epoxy glue to each 6- by 21-inch side of the beams on the beams' neutral axes at midspan. The tabs should be drilled for attachment of the LVDT's. Cure and condition the beams at 75 ± 5 degrees Fahrenheit for 4 days prior to testing and record the temperature.

B-6. Test Procedure. Place the specimens in the test machine as described in ASTM C 78. Place thin Teflon strips at the point of contact between the test specimens and the load-applying and load-support blocks. While the beams are being prepared for testing, place an additional support block at midspan to prevent premature sagging of the beams. Remove this support block immediately prior to the initiation of load application. Mount the LVDT's on laboratory stands on each side of the beams, and attach the LVDT's to the L-shaped tabs on the sides of the beams. Connect the LVDT's and load cell to the X-Y recorder. Make final adjustments and checks on specimens and test equipment. Apply loading in accordance with ASTM C 78, omitting the initial 1,000-pound load.

B-7. Calculations.

a. The modulus of rupture R is calculated from the following equation (from ASTM C 78)—

$$R = PL/bd^2 \quad (\text{eq B-1})$$

where

R = modulus of rupture, psi

P = maximum applied load, pounds

L = span length, inches (18 inches)

b = average width of beam, inches

d = average depth (height) of beam, inches

b. The modulus of elasticity E is calculated from the following equation:

TM 5-822-5/AFM 88-7, Chap. 1

$$E = \frac{23PL^3}{1296\Delta I} k \quad (\text{eq B-2})$$

where

E=static Young's modulus of elasticity, psi

P=applied load, pounds

L=span length, inches (18 inches)

Δ =deflection of neutral axis, inches, under load P

I=moment of inertia inch⁴ ($=bd^3/12$)

k=Pickett's correction for shear (third-point loading).

(Values of E for bituminous beams should be calculated without using Pickett's correction k for shear.)

B-8. Report. The report shall include the following:

- a.* Gradation of Aggregate.
- b.* Type and Properties of Bituminous Cement.
- c.* Bituminous Concrete Mix Design Properties.
- d.* Bituminous Concrete Beam Properties.
- e.* Modulus of Rupture.
- f.* Modulus of Elasticity.

APPENDIX C

METHOD OF TEST FOR PREFORMED POLYCHLOROPRENE ELASTOMERIC JOINT SEAL JET-FUEL-RESISTANCE

C-1 Scope.

This test method provides a procedure for evaluating the ability of preformed polychloroprene elastomeric (PPE) joint seals to withstand the effects of jet fuel. The effect of fuel is determined by noting the change in weight of the seal before and after immersion in a test fuel.

C-2. Preparation of Specimens.

Compliance with the change in weight requirement shall be determined by tests conducted in accordance with the methods specified using specimens cut from manufactured seals. Three specimens shall be tested for each lot of batch or seal submitted for testing. Each specimen shall be rectangular having dimensions of 60 ± 1 millimeter by 20 ± 1 millimeter by 2 ± 0.1 millimeter. Specimens shall be the thickness of the seal as received when they are less than 2 millimeter thick; otherwise the specimens shall be buffed to a thickness of 2 ± 0.1 millimeter.

C-3. Test Procedures.

Each test specimen shall be weighed to the nearest 0.01 gram and then immersed for 24 ± 0.25 hours in clean test fuel maintained at $49 \pm 1^\circ$ Celsius ($120 \pm 2^\circ$ Fahrenheit). The specimens shall be suspended in the test fuel so that the bottoms of the test specimen are a minimum of 12 millimeter above the container bottom, and there is a minimum of 12 millimeter of test fuel over the tops of the specimens. The container for the test fuel and specimens shall be semiclosed to reduce fuel evaporation and eliminate pressure buildup. The overall dimension of the container shall be deep enough to allow the test specimens to be suspended by wire or string and covered with not less than 12 millimeter

of test fuel. Several specimens of the same material may be immersed in the same container provided each test specimen is separated from any adjacent test specimen and container walls by a minimum of 6 millimeter and the minimum fuel cover is maintained. A constant temperature water bath shall be used to maintain the test fuel and specimens at the $49 \pm 1^\circ$ Celsius ($120 \pm 1^\circ$ Fahrenheit) for 24 hours. Immediately after the 24 hour fuel immersion, the specimens shall be removed from the test fuel and dried in a forced draft oven at $70 \pm 1^\circ$ Celsius ($158 \pm 2^\circ$ Fahrenheit) for 24 ± 0.25 hours. The forced air shall be maintained at an air velocity of 150 to 500 feet per minute. After oven drying, the specimen shall be allowed to cool for 30 minutes at room temperature and then weighed to the nearest 0.01 gram.

C-4. Calculations

The change in weight shall be calculated as follows—

$$\text{Change in weight, percent} = \frac{W_1 - W_2}{W_{1K}} 100$$

where

W_1 = initial specimen weight

W_2 = final weight after immersion and oven drying

The average of three specimens shall be reported as the percent change in weight.

C-5. Requirement.

When tested as specified herein, the PPE joint seal material shall have an average change in weight on exposure to fuel of 25 percent or less.

APPENDIX D

USE OF INSULATION MATERIALS IN PAVEMENTS

D-1. Insulating Materials and Insulated Pavement Systems.

The only acceptable insulating material for use in roads and airfields is extruded polystyrene board-stock. Results from laboratory and field tests have shown that extruded polystyrene does not absorb a significant volume of moisture and that it retains its thermal and mechanical properties for several years, at least. The material is manufactured in board stock ranging from 1 to 4 inches thick. Approval from HQUSACE (CEMP-ET) or the appropriate Air Force Major Command is required for use of insulating materials other than extruded polystyrene.

a. Synthetic insulating material. The use of a synthetic insulating material within a pavement cross section is permissible with the written approval of HQUSACE (CEMP-ET) or the appropriate Air Force Major Command. Experience has shown that surface icing may occur on insulated pavements at times when uninsulated pavements nearby are ice-free and vice versa. Surface icing creates possible hazards to fast-moving motor vehicles. Accordingly, in evaluating alternative pavement sections, the designer should select an insulated pavement only in special cases not sensitive to differential surface icing. Special attention should be given to the need for adequate transitions to pavements having greater or lesser protection against subgrade freezing.

b. Insulated pavement system. An insulated pavement system comprises conventional surfacing and base above an insulating material of suitable thickness to restrict or prevent the advance of sub-freezing temperatures into a frost-susceptible subgrade. Unless the thickness of insulation and overlying layers is sufficient to stop subgrade freezing, additional layers of granular materials are placed between the insulation and the subgrade to contain a portion of the frost zone that extends below the insulation. In consideration of only the thermal efficiency of the insulated pavement system, 1 inch of granular material placed below the insulating layer is much more effective than 1 inch of the same material placed above the insulation. Hence, under the design procedure outlined below, the thickness of the pavement and base above the insulation is determined as the minimum that will meet structural requirements for adequate cover over the relatively weak insulating material. The determination of the thickness of insulation and of additional granular

material is predicated on the placement of the latter beneath the insulation.

D-2. Determination of Thickness of Cover Above Insulation.

On a number of insulated pavements in the civilian sector, the thickness of material above the insulation has been established to limit the vertical stress on the insulation caused by dead loads and wheel loads to not more than one-third of the compressive strength of the insulating material. The Boussinesq equation should be used for this determination. If a major project incorporating insulation is planned, advice and assistance in regard to the structural analysis should be sought from HQUSACE (CEMP-ET) or the appropriate Air Force Major Command.

D-3. Design of Insulated Pavement to Prevent Subgrade Freezing.

Once the thickness of pavement and base above the insulation has been determined, it should be ascertained whether a reasonable thickness of insulation will keep subfreezing temperatures from penetrating through the insulation. Calculations for this purpose make use of the design air and surface freezing indexes and the mean annual soil temperature at the site. If the latter is unknown, it may be approximated by adding 7 degrees Fahrenheit to the mean annual air temperature. If the design surface freezing index cannot be calculated from air temperature measurements at the site, or cannot be estimated using data from nearby sites, it may be estimated by multiplying the design air freezing index by the appropriate n-factor from TM 5-852-6. For paved surfaces kept free from snow and ice, an n-factor of 0.75 should be used. For calculating the required thickness of insulation, the design surface freezing index and the mean annual soil temperature are used with figure D-1 to determine the surface temperature amplitude A . The initial temperature differential V_0 is obtained by subtracting 32 degrees Fahrenheit from the mean annual soil temperature, or it also may be read directly from figures D-1. The ratio V_0/A is then determined. Figure D-2 is then entered with the adopted thickness of pavement and base to obtain the thickness of extruded polystyrene insulation needed to prevent subgrade freezing beneath the insulation. If the required thickness is less than

TM 5-822-5/AFM 88-7, Chap. 1

about 2 to 3 inches, it will usually be economical to adopt for design the thickness given by figures D-2, and to place the insulation directly on the subgrade. If more than about 2 to 3 inches of insulation are required to prevent subgrade freezing, it usually will be economical to use a lesser thickness of insulation, underlain by subbase material (S1 or S2). Alternative combinations of thicknesses of extruded polystyrene insulation and granular material base

and subbase) to contain completely the zone of freezing can be determined from figure D-3, which shows the total depth of frost for various freezing indexes, thicknesses of extruded polystyrene insulation, and base courses. The thickness of subbase needed to contain the zone of freezing is the total depth of frost penetration less the total thickness of pavement, base, and insulation.

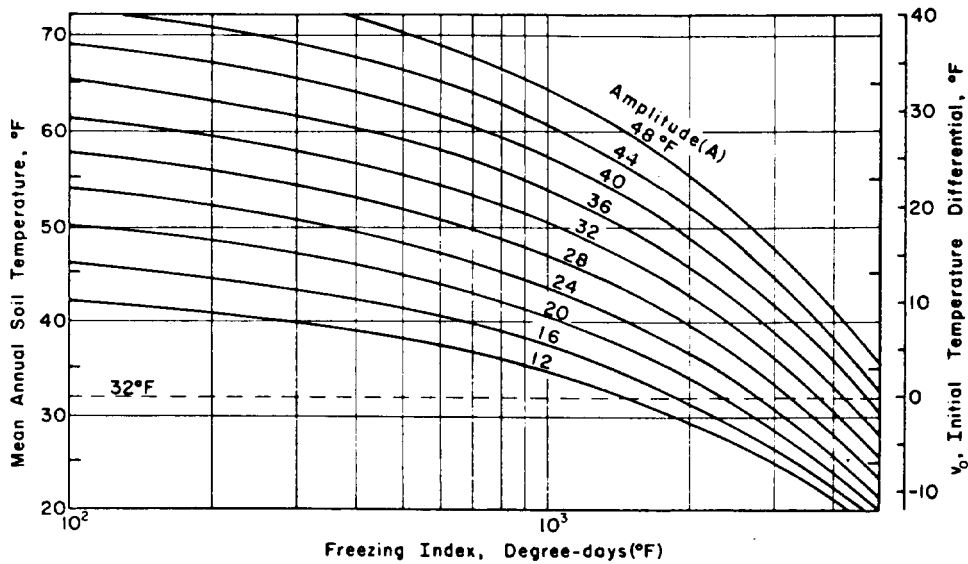
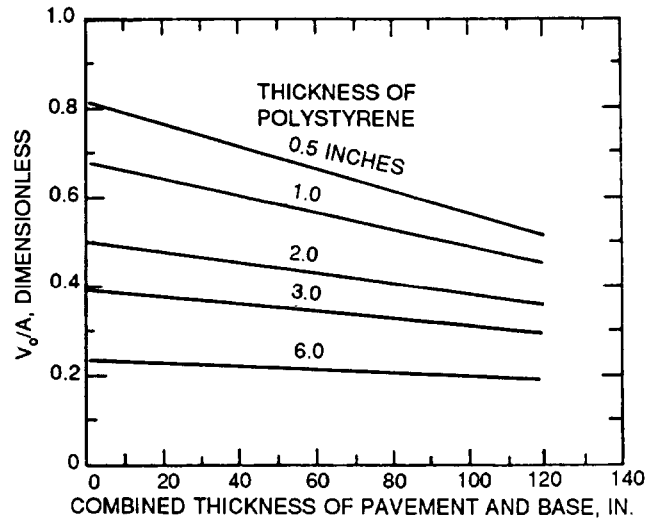

Figure D-1. Equivalent Sinusoidal Surface Temperature Amplitude A and Initial Temperature Difference V_0 .



NOTES

DESIGN CURVES BASED ON THE FOLLOWING MATERIAL PROPERTIES:
 PAVEMENT: SAME THERMAL PROPERTIES AS UPPER BASE
 BASE: $Y_d = 135$ PCF, $w = 7$ PERCENT
 EXTRUDED POLYSTYRENE INSULATION

$$Y_d = 2.0 \text{ PCF, } \underline{K} = 0.21 \frac{\text{BTU IN.}}{\text{FT}^2 \text{ HR } ^\circ\text{F}}$$

Figure D-2. Thickness of Extruded Polystyrene Insulation to Prevent Subgrade Freezing.

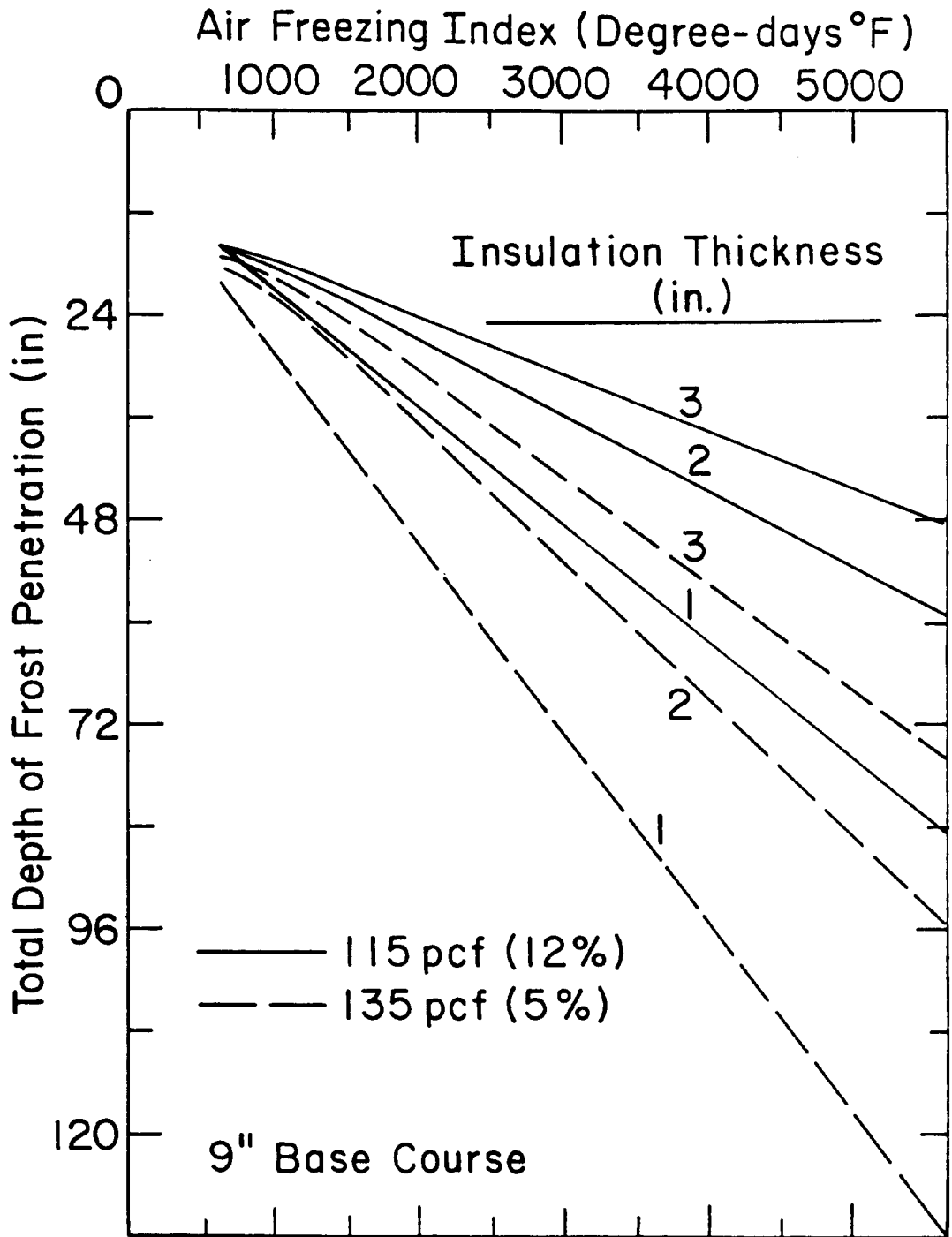

Figure D-3. Effect of Thickness of Insulation and Base on Frost Penetration. (Sheet 1 of 4)

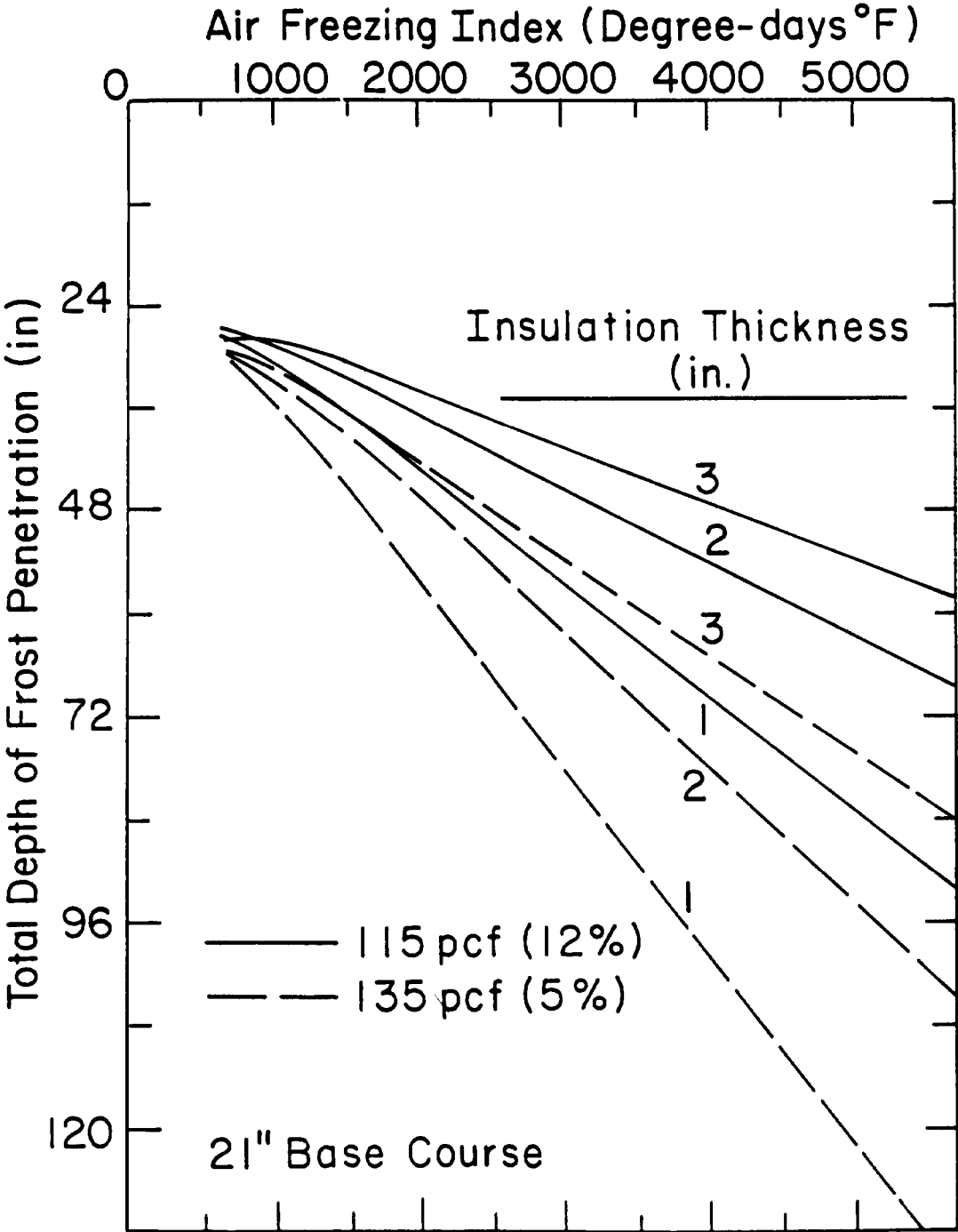

Figure D-3. Effect of Thickness of Insulation and Base on Frost Penetration. (Sheet 2 of 4)

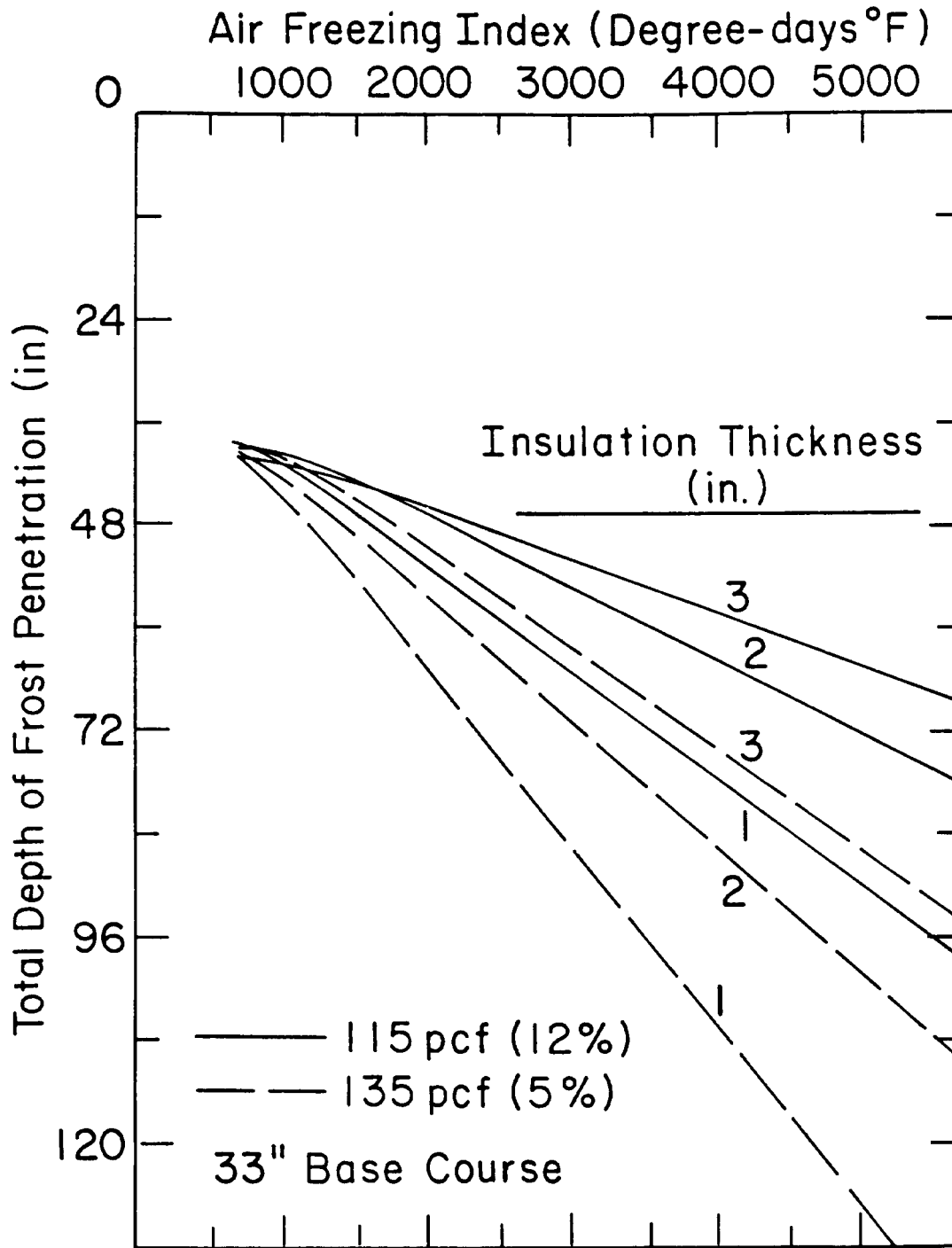

Figure D-3. Effect of Thickness of Insulation and Base on Frost Penetration. (Sheet 3 of 4)

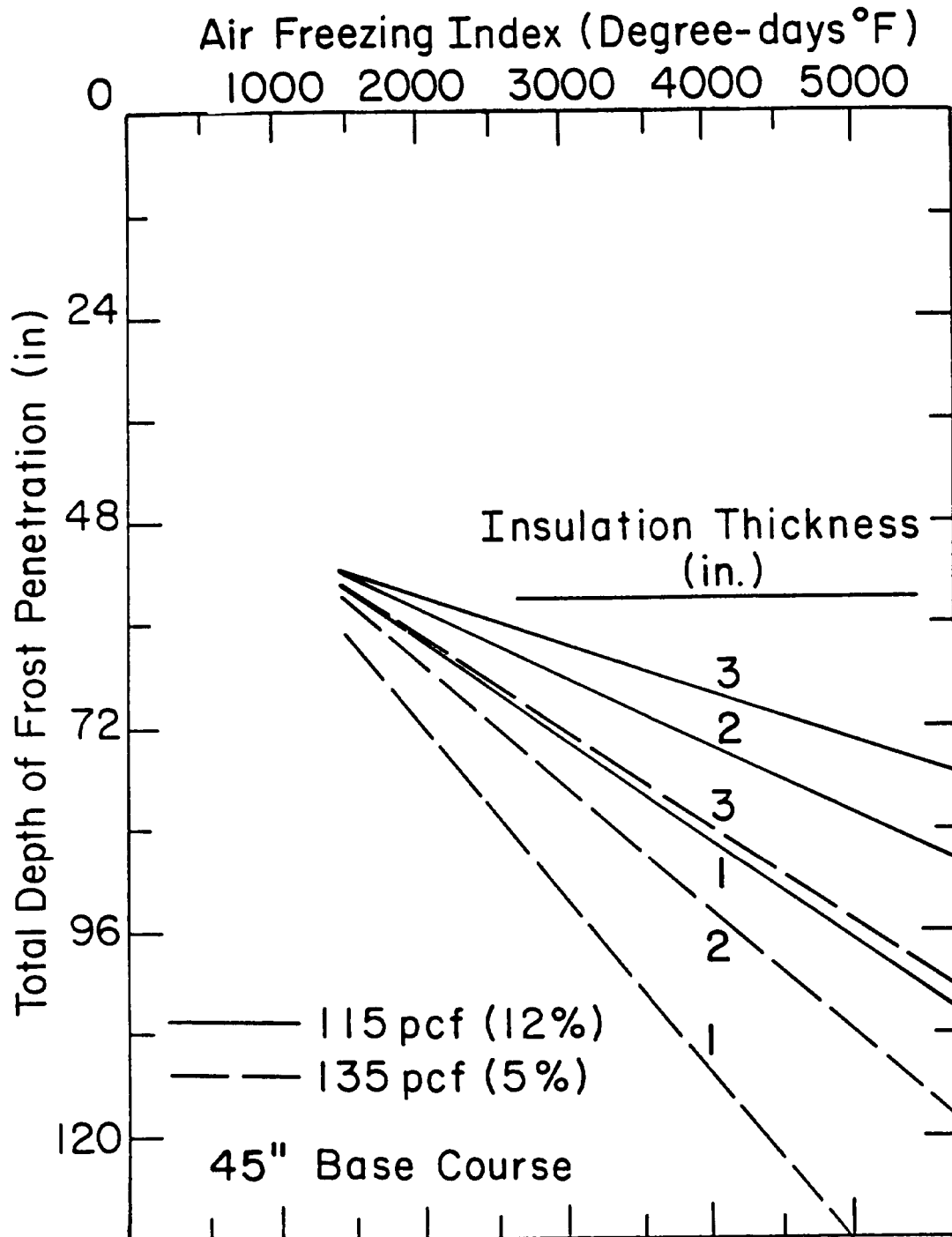

Figure D-3. Effect of Thickness of Insulation and Base on Frost Penetration. (Sheet 4 of 4)

D-4. Design of Insulated Pavement for Limited Subgrade Freezing.

It may be economically advantageous to permit some penetration of frost into the subgrade. Accordingly, the total depth of frost penetration given by figure D-3 may be taken as the value a in figure 18-3, and a new combined thickness b of base, insulation, and subbase is determined that permits limited frost penetration, into the sub-grade. The

thickness of subbase needed beneath the insulation is obtained by subtracting the previously established thicknesses of base, determined from structural requirements, and of insulation, determined from figure D-3. Not less than 4 inches of subbase material meeting the requirements of chapter 18 should be placed between the insulation and the subgrade. If less than 4 inches of subbase material is necessary, consideration should be given to

TM 5-822-5/AFM 88-7, Chap. 1

decreasing the insulation thickness and repeating the process outlined above.

D-5. Construction Practice.

While general practice has been to place insulation in two layers with staggered joints, this practice should be avoided at locations where subsurface moisture flow or a high groundwater table may be experienced. In the latter cases it is essential to

provide means for passage of water through the insulation to avoid possible excess hydrostatic pressure in the soil on which the insulating material is placed. Free drainage may be provided by leaving the joints between insulating boards slightly open, or by drilling holes in the boards, or both. HQUSACE (CEMP-ET) or the appropriate Air Force Major Command may be contacted for more detailed construction procedures.

APPENDIX E
COMPUTER AIDED DESIGN
FOR
FLEXIBLE ROAD PAVEMENTS/RIGID ROAD PAVEMENTS

Floppy disk in pocket of cover 3 contains computer aided programs for Flexible Road Pavements, Version 1.0 and Rigid Road Pavements, Version 1.0.

The proponent agency of this publication is the office of the Chief of Engineers, United States Army. Users are invited to send comments and suggested improvements on DA Form 2028 (Recommended Changes to Publications and Blank Forms) to HQUSACE (CEMP-ET), WASH, DC 20314-1000.

By Order of the Secretaries of the Army and Air Force:

Official:

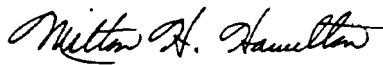

MILTON H. HAMILTON
*Administrative Assistant to the
Secretary of the Army*

GORDON R. SULLIVAN
*General, United States Army
Chief of Staff*

Official:

EDWARD A. PARDINI
*Colonel, USAF Director of Information
Management and Administration*

MERILL A. McPEAK
General, USAF Chief of Staff

Distribution:

Army: To be distributed in accordance with DA Form 12-34-E, requirements for TM 5-822-5.
Air Force: F

* U.S. GOVERNMENT PRINTING OFFICE : 1992 O 323-971

