



PDHonline Course E104 (12 PDH)

Power Systems - Basic Concepts and Applications - Part I

Instructor: Shih-Min Hsu, Ph.D., P.E.

2020

PDH Online | PDH Center

5272 Meadow Estates Drive
Fairfax, VA 22030-6658
Phone: 703-988-0088
www.PDHonline.com

An Approved Continuing Education Provider

Power Systems - Basic Concepts and Applications

Part I

By Shih-Min Hsu, Ph.D., P.E.

MODULE 3: Power Factor Correction and its Applications.

Overview

This module will provide the fundamentals of power factor correction and its applications. It also discusses the importance of reactive planning in distribution and transmission systems in Appendix 3A.

Power Factor and Power Triangle

As discussed in Module 1, there are several quantities related to power. It is very important to have a quick overview on these terms and/or definitions. The definitions listed below are taken from IEEE Std 100-1996, "The IEEE Standard Dictionary of Electrical and Electronics Terms-Sixth Edition."

Active power: The time average of the instantaneous power over one period of the wave. For sinusoidal quantities in a two-wire circuit (single-phase system), it is the product of the voltage, the current, and the cosine of the phase angle between them. For balanced three-phase circuits, the total active power is three times of the active power for each terminal (phase).

Reactive power: For sinusoidal quantities in a two-wire circuit, reactive power is the product of the voltage, the current, and the sine of the phase angle between them. In a passive network, reactive power represents the alternating exchange of stored energy (inductive or capacitive) between two areas.

Apparent power: For sinusoidal quantities in either single-phase or three-phase circuits, apparent power is the square root of the sum of the squares of the active and reactive powers.

Power factor: The ratio of the total active power in watts to the total apparent power in voltamperes.

Power factor angle: The angle whose cosine is the power factor.

As shown in Figure 3-1, a *power triangle*, or *P-Q triangle*, is obtained by drawing a line proportional to the active power on the real axes and a line proportional to the reactive power following it (a) up by 90° for a lagging power factor (inductive loads) or (b) down by 90° for a leading power factor (capacitive loads). Then by connecting the starting and ending points (this length is proportional to the apparent power) to form a power triangle. In short, a power triangle is a right triangle consisting of active power, reactive power and apparent power. Since most of loads have lagging power factor, the discussion of compensating a leading power factor load is impractical; therefore, it is out of the scope of this material. If such a need occurs, the method presented here can still be helpful.

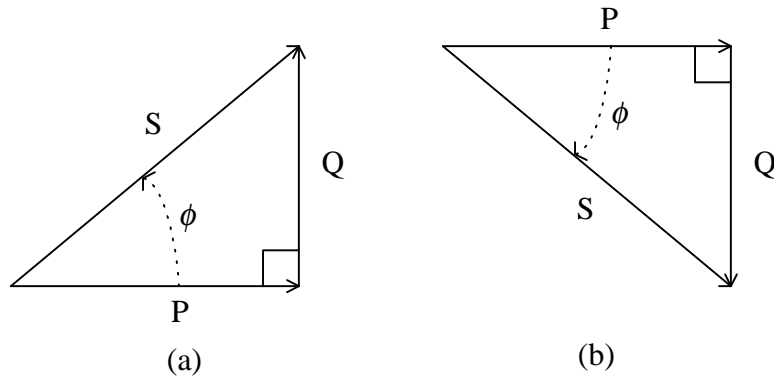

Fig. 3-1. Power triangles with (a) lagging power factor and (b) leading power factor.

From geometry, the three edges of a right triangle have a very important relation – Pythagorean relation, namely,

$$S^2 = P^2 + Q^2,$$

or

$$S = \sqrt{P^2 + Q^2}.$$

Either one of these equations is useful to explain the idea of power factor correction. First of all, for a pure resistive load, its reactive power is zero. Therefore, $S = P$, and power factor is 1, or unity. Other than pure resistive loads, for instance, an inductive load, the amount of its reactive power will determine its power factor, the larger the reactive power the poorer the power factor. This can be seen from the above equations, the larger the reactive power, the larger the apparent power while the active power remain the same. Therefore, the power factor, the ratio of active power to apparent power, is lower. One can use power factor angle to visualize the above observation. When the load is drawing more reactive power, the power angle will be larger. The larger the power factor angle, the lower its power factor will be since power factor is the cosine of the power factor angle.

Power Factor Correction

Since the power bill is based on the usage of the active power – kilo-watt-hour (kWh) while the power system equipment is built to handle the apparent power, the power company may charge a higher rate for loads drawing below a certain power factor, for instance, 0.95. It is mainly applied to large industrial loads/customers. Power factor penalties differ from one company to another. Such penalties serve one important function – to provide incentive to customers for power factor correction. By spending some money on power factor correction at the front end, customers can save money on lower power payment every month. Therefore, in a long run, money can be saved. It is very important to realize the economics of power factor correction.

To correct the lagging power factor, capacitor banks can be used. Assuming that a motor load has a power triangle as shown in Figure 3-1 (a), and its existing power factor is $\cos\phi$ lagging. If a desired power factor is $\cos\phi_{\text{new}}$ lagging, then the new power triangle can be obtained. With power factor corrected, the net reactive power supplied by the source is reduced to its new value, namely,

$$Q_{\text{new}} = P \times \tan \phi_{\text{new}} .$$

The size of the capacitor bank required, Q_{cap} , to compensate the load reactive power to its new value can be calculated as:

$$Q_{\text{cap}} = P(\tan \phi - \tan \phi_{\text{new}}) .$$

Figure 3-2 provides a graphical illustration on power factor correction.

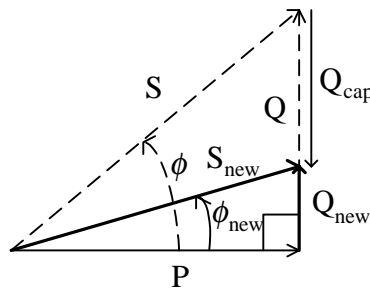

Fig. 3-2. Power triangles before and after power factor correction.

Since the reactive power generated by a single-phase capacitor bank is

$$Q_{\text{cap}} = \frac{V^2}{X_c} = \omega CV^2 .$$

Therefore, the corresponding capacitance of the capacitor bank can be obtained by

$$C = \frac{Q_{\text{cap}}}{\omega V^2} .$$

Example 3-1: A distribution system is represented as the single-phase circuit shown in Figure 3-3.

- Find the apparent power S , active power P , reactive power Q and the power factor pf of the load.
- If a 0.95 lagging power factor is desired, what capacitance (in F) should be connected across the line to correct the power factor to the desired value.
- Draw the power triangles before and after power factor correction.

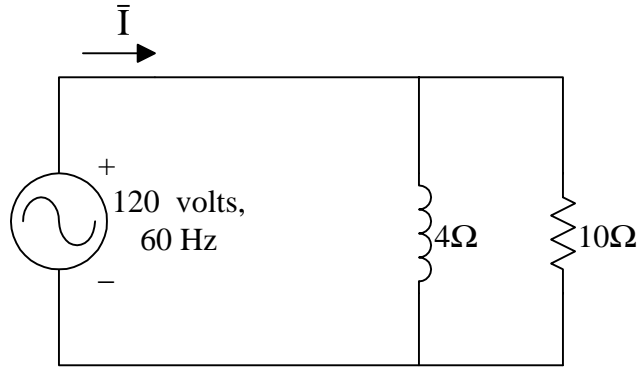

Fig. 3-3. A single-phase distribution system.

Solution:

$$(a) \quad \bar{Z} = \frac{1}{\frac{1}{10} + \frac{1}{j4}} = \frac{1}{0.1 - j0.25} = 3.7139 \angle 68.2^\circ \Omega$$

$$\bar{I} = \frac{120 \angle 0^\circ}{3.7139 \angle 68.2^\circ} = 32.311 \angle -68.2^\circ \text{ amps}$$

$$\bar{S} = \bar{V}\bar{I}^* = (120 \angle 0^\circ)(32.311 \angle -68.2^\circ)^* = 3877.3 \angle 68.2^\circ = 1440 + j3600 = P + jQ \text{ VA}$$

Therefore, $P = 1440 \text{ W}$, $Q = 3600 \text{ var}$ and $S = 3877.3 \text{ VA}$.

$$\text{pf} = \frac{1440}{3877.3} = 0.3714 \quad \text{or,} \quad \text{pf} = \cos(68.2^\circ) = 0.3714$$

$$(b) \quad \text{pf}_{\text{new}} = \cos \phi_{\text{new}} = 0.95$$

$$\phi_{\text{new}} = \cos^{-1}(0.95) = 18.2^\circ$$

$$P_{\text{new}} = P = 1440 \text{ W}$$

$$S_{\text{new}} = \frac{P_{\text{new}}}{\text{pf}_{\text{new}}} = \frac{1440}{0.95} = 1515.8 \text{ VA}$$

$$Q_{\text{new}} = \sqrt{S_{\text{new}}^2 - P_{\text{new}}^2} = \sqrt{(1515.8)^2 - (1440)^2} = 473.3 \text{ var}$$

The reactive power provided by the capacitor bank

$$Q_{\text{cap}} = Q - Q_{\text{new}} = 3600 - 473.3 = 3126.7 \text{ var}$$

or

$$Q_{\text{cap}} = P(\tan \phi - \tan \phi_{\text{new}}) = 1440 \times [\tan(68.2^\circ) - \tan(18.2^\circ)] = 3126.8 \text{ var}$$

Therefore, the capacitor bank in Farad can be calculated as

$$C = \frac{Q_{\text{cap}}}{\omega V^2} = \frac{3126.7}{377 \times 120^2} = 5.76 \times 10^{-4} \text{ F}$$

(c) The power triangles before and after power factor correction is shown below.

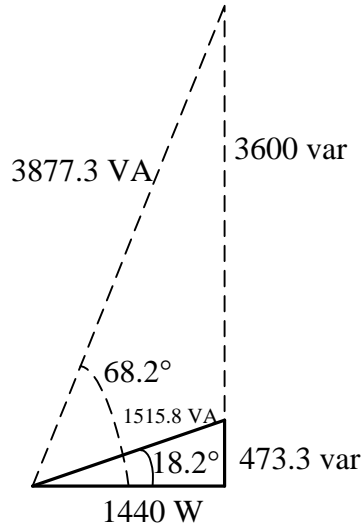

Fig. 3-4. Power triangles before and after power factor correction.

For three-phase systems, the calculations for power factor correction problems are similar. In this case, the reactive power generated by a balanced three-phase capacitor bank can be calculated by

$$Q_{\text{cap}} = \frac{3V^2}{X_C},$$

where X_C is the ohmic value of each capacitor in the bank and where a) if the capacitors are connected in wye, the voltage in the above equation is the phase voltage, and b) if the capacitors are connected in delta, the voltage in the above equation is the line voltage.

Example 3-2: Figure 3-5 shows two 460-volt motors being supplied by a cable.

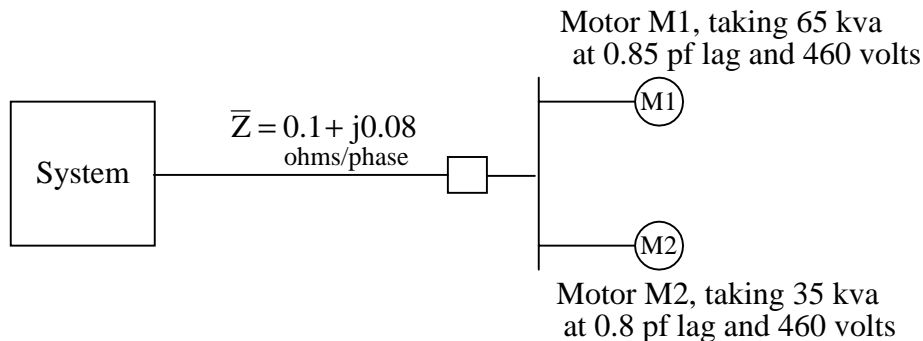

Fig. 3-5. Two motors supplied by a cable.

- (a) Compute the value of the cable current.
- (b) Compute the system voltage magnitude.
- (c) Determine capacitive ohms per phase of a wye connected set of capacitors connected at the system end which causes the sending end to see a load operating at a power factor of 0.95 lagging.

Solution:

- (a) The magnitudes of the currents taken by Motors 1 and 2 are computed as

$$I_1 = \frac{65000}{\sqrt{3}(460)} = 81.58 \text{ amps}$$

$$I_2 = \frac{35000}{\sqrt{3}(460)} = 43.93 \text{ amps}$$

Let the phase voltage at the motors be the reference

$$V_\phi = \frac{460}{\sqrt{3}} \angle 0^\circ = 265.58 \angle 0^\circ \text{ volts}$$

Then the motor phasor currents are

$$\bar{I}_1 = 81.58 \angle -\cos^{-1}(0.85) = 81.58 \angle -31.79^\circ \text{ amps}$$

$$\bar{I}_2 = 43.93 \angle -\cos^{-1}(0.8) = 43.93 \angle -36.87^\circ \text{ amps}$$

The total cable current can be obtained as

$$\bar{I} = \bar{I}_1 + \bar{I}_2 = (69.343 - j42.975) + (35.144 - j26.358) = 125.4 \angle -33.57^\circ \text{ amps}$$

- (b) The system phase voltage is computed using the per-phase circuit shown in Figure 3-6 as a guide.

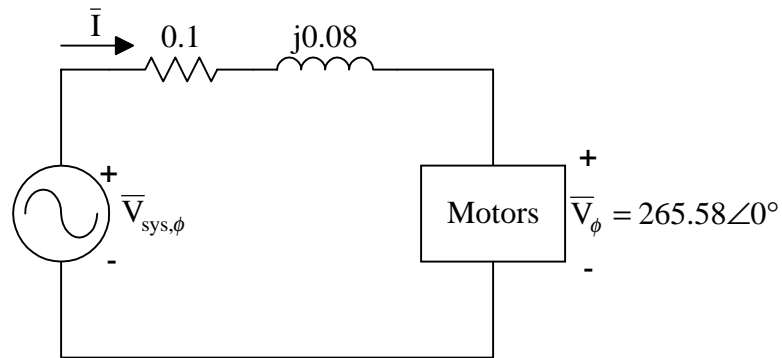

Fig. 3-6. A per-phase representation for a balanced three-phase system in Example 3-2.

By KVL

$$\bar{V}_{\text{sys},\phi} = 265.58 \angle 0^\circ + (0.1 + j0.08) \times (125.4 \angle -33.57^\circ) = 281.58 \angle 0.29^\circ \text{ volts}$$

The magnitude of the line-to-line system voltage is obtained by

$$|\bar{V}_{\text{sys}}| = \left| \sqrt{3}(281.58 \angle -0.29^\circ) \right| = 487.71 \text{ volts}$$

- (c) Because of the convenience of using the P-Q triangle for reactive compensation, the value of $P + jQ$ input to the cable is calculated. The $P + jQ$ is calculated by VI^* where V is the system phase voltage and I^* is the conjugate of the phasor current. So, the $P + jQ$ per-phase is

$$\bar{S}_{\text{sys},\phi} = (265.58 \angle 0.29^\circ)(125.4 \angle -33.57^\circ)^* = 29322.5 + j19671.6 = P + jQ \text{ VA/phase}$$

For the desired power factor of 0.95 with $P = 29322.5 \text{ W}$, the desired (after compensation) can be calculated as

$$Q_{\text{new}} = (29322.5) \times \tan(\cos^{-1}(0.95)) = 9637.8 \text{ var/phase}$$

The P-Q triangles before and after power factor correction are obtained as shown in Figure 3-7.

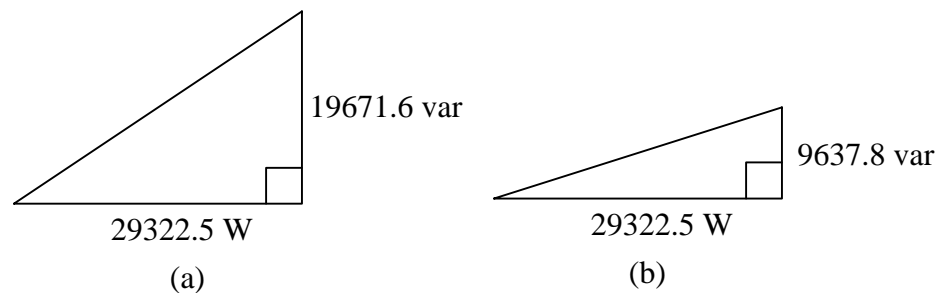

Fig. 3-7. (a) P-Q triangle for the given situation. (b) P-Q triangle for the desired situation.

The capacitive vars per-phase are computed as

$$Q_{\text{cap}} = 19671.6 - 9637.8 = 10033.8 \text{ var}$$

or

$$Q_{\text{cap}} = P(\tan \phi - \tan \phi_{\text{new}}) = 29322.5 \times [\tan(0.29^\circ + 33.57^\circ) - \tan(\cos^{-1}(0.95))] = 10033.8$$

The wye-connected ohms per phase are computed as

$$X_C = \frac{281.58^2}{10033.8} = 7.9 \ \Omega$$

◆

From the two examples, it would be very handy to have a table containing multipliers for power factor correction. For instance, if the active power and power factor of a given condition are known, then by specifying the desired power factor the reactive power required from capacitor bank can be quickly estimated by multiplying the active power and the corresponding multiplier from the table. In Example 3-2, $P = 29322.5 \text{ W}$ and existing power factor is $\cos(0.29^\circ + 33.57^\circ) = 0.83$, and the desired power factor is 0.95, therefore, the corresponding multiplier should be 0.343. The reactive power required per phase is

$$Q_{\text{cap}} = P \times \text{Multiplier} = (29322.5) \times (0.343) = 10057.6 \text{ var},$$

which is fairly close to the calculated value of 10033.8 var. Table 3-1 tabulated the power factor correction multipliers for a quick reference.

Table 3-1. Power factor correction multipliers:

Existing pf (lagging)	Desired pf (lagging)															
	0.85	0.86	0.87	0.88	0.89	0.90	0.91	0.92	0.93	0.94	0.95	0.96	0.97	0.98	0.99	1.00
0.5	1.112	1.139	1.165	1.192	1.220	1.248	1.276	1.306	1.337	1.369	1.403	1.440	1.481	1.529	1.590	1.732
0.51	1.067	1.093	1.120	1.147	1.174	1.202	1.231	1.261	1.291	1.324	1.358	1.395	1.436	1.484	1.544	1.687
0.52	1.023	1.049	1.076	1.103	1.130	1.158	1.187	1.217	1.247	1.280	1.314	1.351	1.392	1.440	1.500	1.643
0.53	0.980	1.007	1.033	1.060	1.088	1.116	1.144	1.174	1.205	1.237	1.271	1.308	1.349	1.397	1.458	1.600
0.54	0.939	0.965	0.992	1.019	1.046	1.074	1.103	1.133	1.163	1.196	1.230	1.267	1.308	1.356	1.416	1.559
0.55	0.899	0.925	0.952	0.979	1.006	1.034	1.063	1.092	1.123	1.156	1.190	1.227	1.268	1.315	1.376	1.518
0.56	0.860	0.886	0.913	0.940	0.967	0.995	1.024	1.053	1.084	1.116	1.151	1.188	1.229	1.276	1.337	1.479
0.57	0.822	0.848	0.875	0.902	0.929	0.957	0.986	1.015	1.046	1.079	1.113	1.150	1.191	1.238	1.299	1.441
0.58	0.785	0.811	0.838	0.865	0.892	0.920	0.949	0.979	1.009	1.042	1.076	1.113	1.154	1.201	1.262	1.405
0.59	0.749	0.775	0.802	0.829	0.856	0.884	0.913	0.942	0.973	1.006	1.040	1.077	1.118	1.165	1.226	1.368
0.6	0.714	0.740	0.767	0.794	0.821	0.849	0.878	0.907	0.938	0.970	1.005	1.042	1.083	1.130	1.191	1.333
0.61	0.679	0.706	0.732	0.759	0.787	0.815	0.843	0.873	0.904	0.936	0.970	1.007	1.048	1.096	1.157	1.299
0.62	0.646	0.672	0.699	0.726	0.753	0.781	0.810	0.839	0.870	0.903	0.937	0.974	1.015	1.062	1.123	1.265
0.63	0.613	0.639	0.666	0.693	0.720	0.748	0.777	0.807	0.837	0.870	0.904	0.941	0.982	1.030	1.090	1.233
0.64	0.581	0.607	0.634	0.661	0.688	0.716	0.745	0.775	0.805	0.838	0.872	0.909	0.950	0.998	1.058	1.201
0.65	0.549	0.576	0.602	0.629	0.657	0.685	0.714	0.743	0.774	0.806	0.840	0.877	0.919	0.966	1.027	1.169
0.66	0.519	0.545	0.572	0.599	0.626	0.654	0.683	0.712	0.743	0.775	0.810	0.847	0.888	0.935	0.996	1.138
0.67	0.488	0.515	0.541	0.568	0.596	0.624	0.652	0.682	0.713	0.745	0.779	0.816	0.857	0.905	0.966	1.108
0.68	0.459	0.485	0.512	0.539	0.566	0.594	0.623	0.652	0.683	0.715	0.750	0.787	0.828	0.875	0.936	1.078
0.69	0.429	0.456	0.482	0.509	0.537	0.565	0.593	0.623	0.654	0.686	0.720	0.757	0.798	0.846	0.907	1.049
0.7	0.400	0.427	0.453	0.480	0.508	0.536	0.565	0.594	0.625	0.657	0.692	0.729	0.770	0.817	0.878	1.020
0.71	0.372	0.398	0.425	0.452	0.480	0.508	0.536	0.566	0.597	0.629	0.663	0.700	0.741	0.789	0.849	0.992
0.72	0.344	0.370	0.397	0.424	0.452	0.480	0.508	0.538	0.569	0.601	0.635	0.672	0.713	0.761	0.821	0.964
0.73	0.316	0.343	0.370	0.396	0.424	0.452	0.481	0.510	0.541	0.573	0.608	0.645	0.686	0.733	0.794	0.936
0.74	0.289	0.316	0.342	0.369	0.397	0.425	0.453	0.483	0.514	0.546	0.580	0.617	0.658	0.706	0.766	0.909
0.75	0.262	0.289	0.315	0.342	0.370	0.398	0.426	0.456	0.487	0.519	0.553	0.590	0.631	0.679	0.739	0.882
0.76	0.235	0.262	0.288	0.315	0.343	0.371	0.400	0.429	0.460	0.492	0.526	0.563	0.605	0.652	0.713	0.855
0.77	0.209	0.235	0.262	0.289	0.316	0.344	0.373	0.403	0.433	0.466	0.500	0.537	0.578	0.626	0.686	0.829
0.78	0.183	0.209	0.236	0.263	0.290	0.318	0.347	0.376	0.407	0.439	0.474	0.511	0.552	0.599	0.660	0.802
0.79	0.156	0.183	0.209	0.236	0.264	0.292	0.320	0.350	0.381	0.413	0.447	0.484	0.525	0.573	0.634	0.776
0.8	0.130	0.157	0.183	0.210	0.238	0.266	0.294	0.324	0.355	0.387	0.421	0.458	0.499	0.547	0.608	0.750
0.81	0.104	0.131	0.157	0.184	0.212	0.240	0.268	0.298	0.329	0.361	0.395	0.432	0.473	0.521	0.581	0.724
0.82	0.078	0.105	0.131	0.158	0.186	0.214	0.242	0.272	0.303	0.335	0.369	0.406	0.447	0.495	0.556	0.698
0.83	0.052	0.079	0.105	0.132	0.160	0.188	0.216	0.246	0.277	0.309	0.343	0.380	0.421	0.469	0.530	0.672
0.84	0.026	0.053	0.079	0.106	0.134	0.162	0.190	0.220	0.251	0.283	0.317	0.354	0.395	0.443	0.503	0.646
0.85	0.000	0.026	0.053	0.080	0.107	0.135	0.164	0.194	0.225	0.257	0.291	0.328	0.369	0.417	0.477	0.620
0.86		0.000	0.027	0.054	0.081	0.109	0.138	0.167	0.198	0.230	0.265	0.302	0.343	0.390	0.451	0.593
0.87			0.000	0.027	0.054	0.082	0.111	0.141	0.172	0.204	0.238	0.275	0.316	0.364	0.424	0.567
0.88				0.000	0.027	0.055	0.084	0.114	0.145	0.177	0.211	0.248	0.289	0.337	0.397	0.540
0.89					0.000	0.028	0.057	0.086	0.117	0.149	0.184	0.221	0.262	0.309	0.370	0.512
0.9						0.000	0.029	0.058	0.089	0.121	0.156	0.193	0.234	0.281	0.342	0.484
0.91							0.000	0.030	0.060	0.093	0.127	0.164	0.205	0.253	0.313	0.456
0.92								0.000	0.031	0.063	0.097	0.134	0.175	0.223	0.284	0.426
0.93									0.000	0.032	0.067	0.104	0.145	0.192	0.253	0.395
0.94										0.000	0.034	0.071	0.112	0.160	0.220	0.363

Note: Multiplier = $\tan(\cos^{-1} \text{pf}) - \tan(\cos^{-1} \text{pf}_{\text{new}})$