



PDHonline Course E147 (5 PDH)

Modern Closed Circuit TV Design (Audio Version)

Instructor: Thomas Mason, P.E.

2020

PDH Online | PDH Center

5272 Meadow Estates Drive
Fairfax, VA 22030-6658
Phone: 703-988-0088
www.PDHonline.com

An Approved Continuing Education Provider

Modern Closed Circuit TV Design

Course Content

A closed circuit TV system is made up of cameras, connections to the control point, controls, displays and, usually, storage. It is a difficult decision to buy a cctv system, but after it is made, more cameras, more displays and more storage are relatively inexpensive. Each of these components will be discussed in terms of technical characteristics, use and performance, design specification and drawings and budgetary pricing.

Analog and digital components can be combined for cctv systems. Today, digital camera sensors are converted to analog signals for transmission. The entire system can be analog. However, it is becoming more common and much less expensive, to convert the camera signal to digital packets, transmit it by a local area network (lan) and provide all downstream processing and storage using lan and personal computer devices. After cameras are discussed, analog-TV and IP-TV will be addressed.

A graphic representation of a closed circuit television system is presented below.

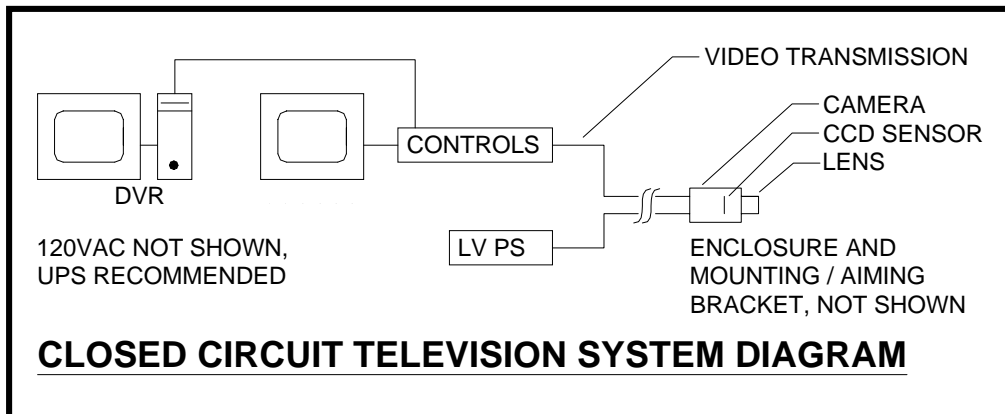

Sharing Events with Large Audiences: The primary focus of this course is security applications. These can be life-safety situations and deserve close attention and care. However, the skills in developing a functional, reliable cctv system can be valuably applied to a church with more parishioners or wedding guests than seating. It can be used for public meetings that exceed the capacity of the venue. Within limits, it can be used to share public performances with homebound parents

A quality public address system is already in place in churches, schools and public auditoriums. The only requirement for sharing events to locations which have speakers is the installation of a camera, a cable and one or more monitors. This course discusses camera selection, cable selection and monitor selection.

Sharing of public performances is technically feasible with actually less work (less cost and fewer man-hours) than installing remote monitors. The IP-TV technology discussed in the course readily lends itself to access via the internet. Required is a netcam (\$300) and an audio pickup option (\$150). It must be assigned an internet address and connected to a local area network and to the internet.

There are limits on sharing public performances with homebound parents. First, it is probably a violation of copyright law to distribute Broadway musicals. It is probably not a violation to distribute choir performance of public domain or local arrangements. In between requires judgment.

Second, the netcam technology presented here is confidently rated by its manufacturer to support 10 viewers concurrently. It has been tested successfully with 30 concurrent viewers. It almost certainly will not work to distribute graduation to 4,000 remote grandparents. (The manufacturer says this is feasible with use of a "mirror server", but that is a substantial information technology undertaking not addressed by this course.)

Third, sound is as important as image. An existing quality public address system solves this problem without attention or investment. Remote listening will be difficult. The sound option on the netcam is a box with a sound hole which is located at the camera. It will not pick up good sound, except for coughing by audience near the camera. The sound option accepts external microphone input, but microphones, a mixer and a skilled operator are a major undertaking. Remote sound has not been investigated in detail, but firms who do web broadcasts almost universally use telephone conference sound services.

Fixed CCTV Camera: A cctv camera is made up of the lens, sensor, power supply, signal delivered and enclosure. Sound may be transmitted. These will be discussed individually.

Fixed CCTV Camera Lens and Auto-Iris: A lens gathers light from the scene in front of it and squeezes it down to a clear image on the sensor. How big the lens is determines how much light it takes in. The maximum lens opening is the aperture of the lens and the adjustment of the aperture is done by iris control (closing a framing shutter inside the lens). [Note that auto-iris lens fully closes when disconnected and cannot be used without the dc cable connected.] For film cameras, this is very important; for CCD sensors in cctv cameras, it is often not mentioned in the advertisement. This is because the sensor is 1/3-in in diameter or 8mm across. Film is 35mm up-and-down, or about 50mm across. It takes 64x glass to make a decent film lens. Most unlabeled cctv lenses are f/1.4 or f/2.0. In cctv, low-light sensitivity is a sensor feature, not a lens selection.

Choosing a cctv lens means choosing the focal length (mm), iris control and fixed or varifocal (or zoom). Focal length determines field of view (FOV). A standard wide-angle cctv 3.6mm lens has 76 degree FOV and sees 7.5-ft wide at 5-ft, 15.1-ft wide at 10-ft and 104-ft wide at 100-ft (see table below). 7.5-ft at 5-ft means you will see an entire basketball team five feet in front of the camera. Good for over a cash register. 104-ft FOV at 100-ft means that each pixel is 4-in from the next pixel. You can see a car, distinguish it from a pickup, but not identify the make or year and not even identify the color of the license plate.

The table below was expanded from a published table by correcting some errors and adding the 100-ft, 300-ft columns and 25mm, 50mm and 75mm rows. The purpose was to select lenses for cameras on a prison which view the electric gate. It was desired to avoid closing the gate on a car in transit. For the camera 100-ft away, the 50mm lens does a good job and the 25mm is acceptable. For the camera 300-ft away, the 75mm lens is acceptable. This reasoning applies to varifocal as well as fixed lenses. A 7-70mm varifocal for \$90 will do the job, or a 70mm fixed lens for \$45 the same.

A marvelous insight from the table is that a 3.0mm lens has 90-degree view. Four 3.0mm lenses produce a full panorama. With a little care, this arrangement permits four inexpensive fixed cameras to replace a pan, tilt, zoom camera.

LENS CHART (BASED ON USE OF 1/3" IMAGE SENSOR)- NOT 1/4"
 (1/4" view = 0.75x shown value)

Lens focal length	View degree (horiz)	@5'	5'	10'	10'	15'	15'	25'	25'	50'	50'	100'	100'	300'H
		H	V	H	V	H	V	H	V	H	V	H	V	
2.97mm	90	10.0'	6.6'	20.0'	13.2'	30.0'	19.9'	50.0'	33.1'	100'	66.2'	200'	132.0'	
3.6mm	76	7.5'	5.2'	15.1'	10.4'	22.6'	15.6'	37.7'	26.1'	75.4'	52.1'	151.1'	104.0'	
6.0mm	42	3.5'	2.9'	7.7'	5.7'	11.5'	8.6'	19.2'	14.4'	38.4'	28.7'	77.0'	57.0'	
8.0mm	32	2.9'	2.1'	5.7'	4.3'	8.6'	6.4'	14.4'	10.7'	28.7'	21.3'	57.0'	43.0'	
12.0mm	24	1.9'	1.5'	3.9'	3.0'	5.8'	4.5'	9.7'	7.5'	19.4'	14.9'	39.0'	30.0'	
25mm	12											20'		60'
50mm	5.3											10'		30'
75mm	3.5											7'		22'

The comment in the original table about 1/3-in sensor NOT 1/4-in sensor is prejudice against the smaller sensor. As this course is being written, 1/3-in CCD's are better quality than 1/4-in. It is certain that improvements will be made in both and quality 1/4-in cameras will become recognized. Regarding the 0.75x conversion, the same optical image is formed on both sensors. The 1/4-in picks up 1/4-in wide section of the image. The 1/3-in picks up 1/3-in. The image produced is $1/4 / 1/3 = .25 / .33 = 0.75$. The resolution is determined by the quality of the sensor, not the size of the image on it.

Auto-iris is a dc motor on the aperture control of the lens. The camera decides if it is getting too much light and tells the lens to "stop down" and reduce the light gathering. This never happens indoors (unless you focus on a light source). Outside, the daytime light levels vary from 10,000fc to 100fc and auto-iris has value. Against this recommendation are vendor claims that electronic shutters of 1/10,000sec eliminate the need and real-world experience that dc motors eventually fail. Nighttime light levels vary from 100fc to .01fc. The iris is always fully open.

Varifocal CCTV Camera Lens and Auto-Iris: The fixed lens discussion above refers to varifocal lenses without elaboration. For the most part, this is acceptable. A good varifocal lens is essentially interchangeable for any fixed lens within it's range. A 3-8mm varifocal is a 90-degree lens and a 32-degree lens and every lens in between. This works because a 35mm film negative has more than 10megapixel resolution while the 1/3-in CCD has about 0.3megapixel resolution. On a film camera, the lens is the weak link. On a cctv camera, the 525x300 standard is the weak link.

The significant difference between varifocal and fixed lenses is physical size. A C-mount 3.6mm wide-angle (standard) lens is less than 2-cm thick. A C-mount varifocal 5-50mm lens is about 6-cm thick. The board-mount lenses for postage-stamp cameras have the same ratio. A telephoto varifocal lens will not fit in a standard mini-dome enclosure.

Fixed CCTV Camera Sensor and Sensitivity (Lux): The technology of cctv camera sensors is advancing very rapidly and will not be reviewed here. Note that the 525x300 standard limits image quality to something far below the capability of available sensors and electronics. Because of the tremendous inertia of the industry and the widespread acceptance of commercial TV and HDTV, it is unlikely that high-resolution CCTV will grow rapidly.

However, IP-TV cameras are just being introduced with 1600x1200 resolution. Prices are \$1,500-\$2,500 without weatherproof enclosure. They are compatible with 100MB local area networks and compatible with IP digital video recorders and computer screens.

Light sensitivity is rated in lux. 1 footcandle (fc) is 11 lux. 1.0 lux is a situation where the human eye can pick out forms but not avoid tripping over objects. All commercial cctv cameras deliver a decent picture at 1.0 lux. Below 1.0 lux, color cameras switch to black and white image and some stress is placed upon the sensor. Very ordinary cameras deliver an image at 0.1 lux (dark night) and some deliver at 0.01 (a little sky haze). Infrared pickup cameras are available for a very slight premium that deliver an image from up to 30-ft away in absolute darkness by using built-in infrared LED illuminators around the lens.

Fixed CCTV Camera Power Supply: The power supply to a cctv camera is simple, but that are many alternatives - each with special benefits. Until recently, a conventional 120VAC outlet was called for in the above-ceiling space somewhere near the camera. When the security contractor came in, he plugged in a "wall wort" and ran 12VDC or 24VAC telephone wire to the camera. He then ran his video cable back to the control point. This is still commonly done, but is usually illegal, per the National Electric Code and creates a reliability and maintenance problem later.

The conventional method recommended by this course is "siamese cable" made up of a video co-ax and 18/2 power conductors in an overall jacket (plenum-rated jacket if in environmental air space). RG-59 co-ax costs \$100/1,000-ft. RG-59+18/2 in an overall jacket costs \$200/1,000-ft.

There are proprietary schemes to route low-voltage AC or DC on the co-ax. This is not recommended because technicians do not expect to find power on signal cables. Cost is high and special equipment on both ends is required.

A very interesting power supply method is use of an existing local area network or creation of a small segment for the cctv system. Standard LAN wiring is 4-pair #22. The video can be transmitted on one pair through a matching transformer (balun) and low-voltage power can be transmitted through another pair. Multiple pairs can be paralleled for longer power runs.

Cameras are commercially available with built-in baluns and four screw terminals for cable connection. Adapters are available with BNC for video co-ax and telephone wire for power on one side and a RJ-45 jack for LAN connection. This scheme is not recognized by most technicians, but provides an elegant solution to a number of special problems. For instance, it was used recently on the aerial cable for a lift bridge to give the operator cctv of automotive traffic at each end of the bridge.

The power supply to a cctv camera is simple. Much more simple than commonly realized. Pelco, for example, publishes an operating voltage range for some cameras of 8-40 VDC. This means a conventional 12 VDC source can suffer 4 V line drop and the camera is still warranted by the manufacturer to operate properly. On the other end, a 40VDC supply can be provided with no danger to the camera and 32 volts of line drop are acceptable.

The 18/2 power conductors in the siamese cable discussed later will provide good power for 1,000-ft with no special effort. (Co-ax is only good for 650-ft to 900-ft.)

WARNING: A high-reliability installation requires uninterruptible power source (UPS) for the camera, recorder, controls and monitor. This works in favor of the siamese cable with the power source in the same cabinet as the signal termination.

Fixed CCTV Camera Signal Delivered: For over 50-years, a tv camera was connected to a co-axial cable and the cable connected to a monitor. Commonly, a tee-connector was used on the monitor so that the signal could continue to some controls and another monitor. Works fine. In theory, the camera has 75-ohm termination internally, the co-ax has 75-ohm characteristic impedance and the last monitor connected has a 75-ohm termination resistor. (Many monitors have two co-ax connections for "loop thru" and a dip-switch for terminator "on" or "off.") In practice, the rules are broadly ignored and the systems still work fine.

Conventional cctv co-ax is RG/59. (RG/58 is identical to RG/59, but rated 50 ohms instead of 75 ohms.) This is a single-shielded solid conductor with a pvc jacket. RG/59 is a military designation from before World War II. For baseband video (0-6MHz) this is satisfactory. Standard video signal level (1.0V, peak) and video content does not radiate very far and does not cause interference to household entertainment equipment, garage door openers or EMS radios. However, there is both radiation and pickkup through the single-shield, connectors and terminations within the enclosures. Higher quality co-ax is required when the video is modulated to 100MHz for broadband (CATV) applications. Different coaxial cables are illustrated below:

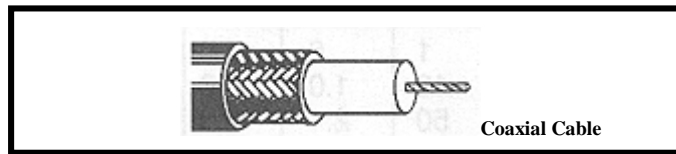

RG/59, Stranded Core (not recommended)

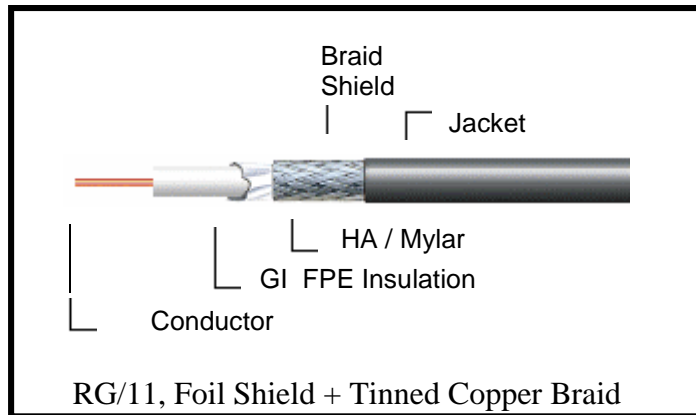

Belden and West Penn are the lead manufacturers of coaxial cable. Others make fine products, but the Belden and West Penn part numbers are usually used for base specifications and cross-referenced to other manufacturers.

A brief aside on connectors is appropriate here. For at least 50-years the standard video connector is the BNC. This stands for something in French about bayonets. It is also called a UHF-connector in ham radio. The BNC male is used on cables and the BNC female is used on the chassis of the equipment for cable connection. BNC males are available in crimp connection, screw-on connection and clamp connection. A good crimp requires the proper tool and proper application but is inexpensive and reliable. Screw-on connections pull out. Wrench connections are premium. The connectors are shown below:

BNC CONNECTORS



BNC Male

Inline crimp for RG58U cable.

CB042 \$1.29



BNC Male

Inline clamp for RG59/62U cable.

CB071 \$1.49

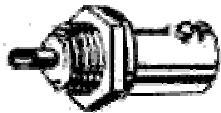

BNC Female

Teflon center silver plated.

CB125 \$1.99



BNC Female

Isolated 3/8" mount, solder leads, one leg grounded.

CB151 \$1.29

The first problem with conventional co-ax transmission is the bundle size. A small system uses 16-cameras. 16-co-ax are the size of a baseball bat and bend only slightly more easily than a baseball bat. You will find bundles of 16-co-ax above the ceiling tiles in many, many stores, schools, factories and offices. Unfortunately, these are illegal, due to two changes in the National Electric Code (NEC). Article 720 specifically applies the NEC to low-voltage wiring. 725.6 requires hangers and 725.61 requires plenum-rated cables in above-ceiling spaces used as HVAC returns. (Plenum-rated cables cost 2x non-plenum cables.)

Cable tray is not addressed in this course. Small bundle hangers are cable-rings, j-hooks and specialized proprietary hangers, such as caddy-clips. Each is illustrated below:



Cable Rings are available with wood screws, masonry anchors or machine screws for beam clamps

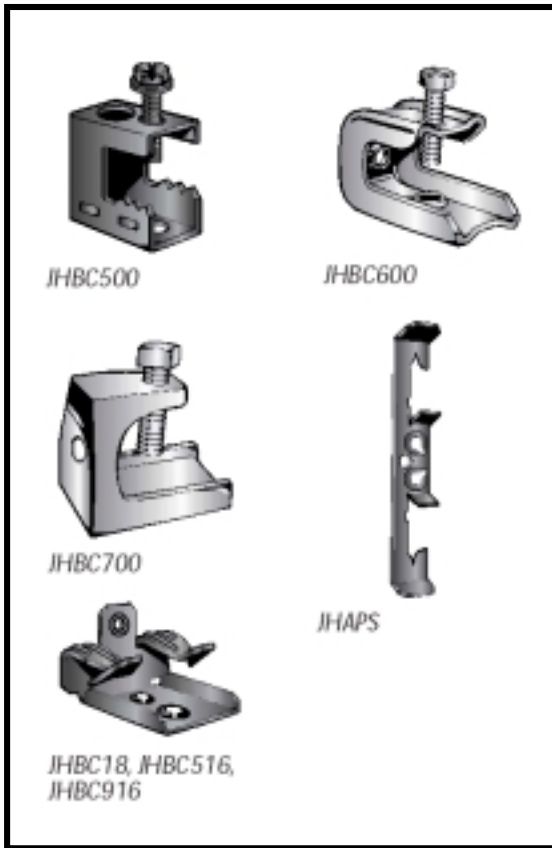

Beam Clamps

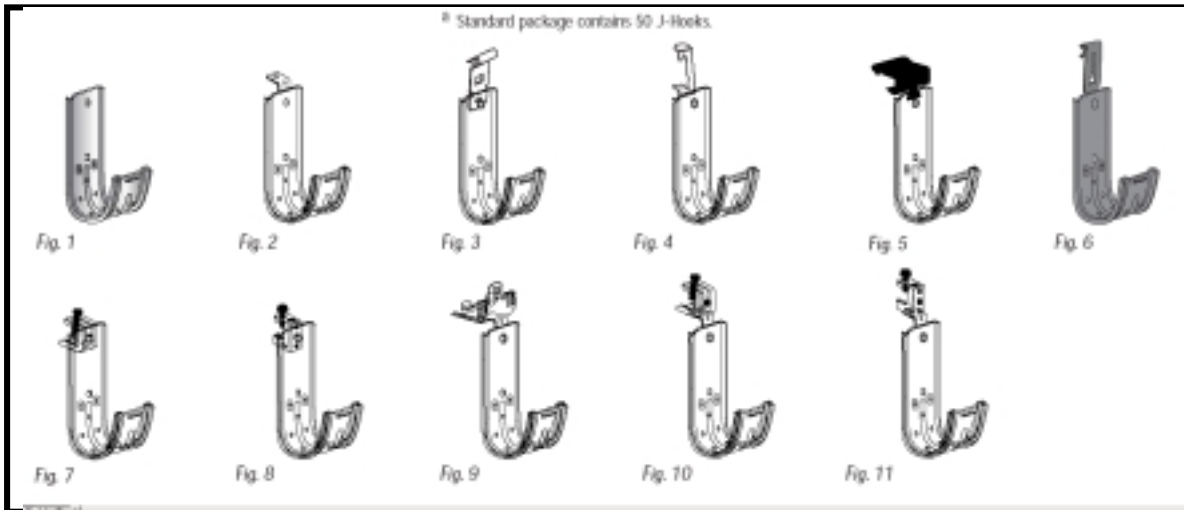

J-Hooks

CADDY CAT TRAX - Installation is a Snap



1. Attach main support to 3/8 threaded rod.



2. Plastic mesh in main support hanger and lock in with spring steel clip.

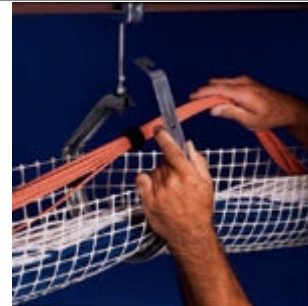

3. Place cable in mesh. Secure with steel retaining strap. (The removable retaining strap allows for future cables.)

Note: this is a guide to installation only. Full instructions will be supplied at time of purchase.

A very attractive alternative signal transmission scheme uses a balancing transformer (balun) on each end. The co-ax is converted to twisted-pair, then back to co-ax. This works very well but is not sufficiently common to be readily recognized by most technicians. A few cameras are available with internal baluns, but none have been encountered with integral RJ-45 connectors to use LAN wiring without an adapter.

Video can be converted to fiber optic easily. This works well for a single camera, but becomes complicated for multiple cameras. The conventional method is to up-convert baseband video (0-6MHz) to one of many radio frequency channels in a common signal. The common signal is sent by fiber optic and de-multiplexed at the other end. This has always been complicated, fragile and expensive.

Today, it is common to convert the co-ax to IP-packets and distribute them over a local area network, using the data switches, equipment and Internet. Data-to-fiber optic converters cost the same as video-to-fiber converters but carry 16- or 32- or 64-cameras. The signal is usually NOT converted back to co-ax at the control room. Rather, it is recorded digitally (hard disk and DVD) and viewed on pc screens.

Internet Wi-Fi IP-TV cameras are being sold fro \$300 to \$2000. They work with an installed Wi-Fi access point and make the image available to anyone with an internet connection and the password. Wi-fi has an inherent security breach, in being continuously on-the-air. Using instructions available from an internet search, anyone can sit with a Wi-Fi laptop computer in the parking lot and work at his leisure to catch the password when accessing an image, guessing the password, or simply watching the images that the legitimate user has accessed. The newest cellular phones deliver IP-TV images. Personal digital assistants with Wi-Fi deliver IP-TV.

Fixed CCTV Camera Enclosure and Heater: The elements of a cctv camera are the lens, lens mount, ccd sensor, electronics and signal delivery cable. The size is about 3-cm x 3-cm x 3-cm. They are available in this form for \$25 to \$100, sometimes including a swivel bracket

for aiming. They are termed “postage stamp cameras” in this course. A sample is pictured below:

<p>CC-8710BVF 1/3" HIGH RESOLUTION COLOR VARI-FOCAL DOME CAMERA Description: with 4.0~8.0mm Vari-Focal Lens 550 TV Lines 0.5 Lux Panasonic Super-View CCD Sensor Power: DC 12V</p>	
--	--

Postage Stamp Camera on Minidome Base, typical specifications, \$130

Better is a metal case with interchangeable lens mount, called a “box camera” or a high-impact transparent dome, called a “mini-dome”. The box camera is externally mounted and aimed. A weatherproof additional enclosure can be provided. A thermostatically-controlled heater can be included in the weatherproof enclosure and a thermostatically-controlled fan can be included if any way can be found to move air without permitting bugs entry. The camera does not require environmental controls, but pan, tilt, zoom and auto-iris are mechanical moving parts and fail later if in an environmental enclosure. One is illustrated below:

<p>80-ft Infrared Day / Night Color High Box Resolution Camera, \$209</p>

This camera has the highest resolution possible and with a .05 lux SONY imaging chip in it you have about the best camera on the market! And with 4 infrared high output LEDs mounted on the front, it sees an incredible 80 ft with no light! Excellent choice for a DVR !

Notes:

- The lens is selected separately (see above). The infrared leds on this camera will reach 80 ft, however you still need to choose the best lens for the distance and angle of view that you desire.
- If you want to use this camera outdoors you need to put it in an outdoor housing. Keep in mind that the housings are not small, they are over a foot long. They look fine in an industrial or business application but some homeowners do not care for the look of the large housing on their home exterior.
- When putting an infrared camera in a housing be sure to put the camera lens flush up to the glass of the housing. This will reduce any glare from the infrared leds off the glass.

Features:

- SONY 1/3" Super HAD EX VIEW CCD sensor
- built in light sensor shuts off light during day
- 480 lines
- 0.0 LUX @ F1.2 (up to 80 ft)
- Auto Iris Control
- Video-Drive Lens & DC-Drive Lens supported
- C or CS mount adjustable
- Auto Gain Control
- 12VDC

A box camera can be placed in a large weatherproof dome, often pendant mounted from the building or existing light pole or dedicated light pole. Environmentally controlled pendant large-domes are available for about \$1,000. Simple domes from the predominant manufacturer are about \$500. Low-cost imports are about \$125 and imported weatherproof minidomes are \$5 to \$50.

A top-end pan, tilt, zoom, auto-iris, environmentally controlled large-dome system lists for \$2,500 and is discounted only a few hundred dollars on the internet. After the mechanicals lock up from normal wear, the camera may still work, but in the last position. A sizeable maintenance cost is confronted, in addition to renting a man lift to work on it. The following alternative is offered for your consideration. The quad multiplexer produces a single 4-way split screen image over a single video cable. The quad has an image resolution of 525x600 and delivers four images of 262x300. Note that essentially no horizontal resolution is lost. On a large screen, the result is acceptable.

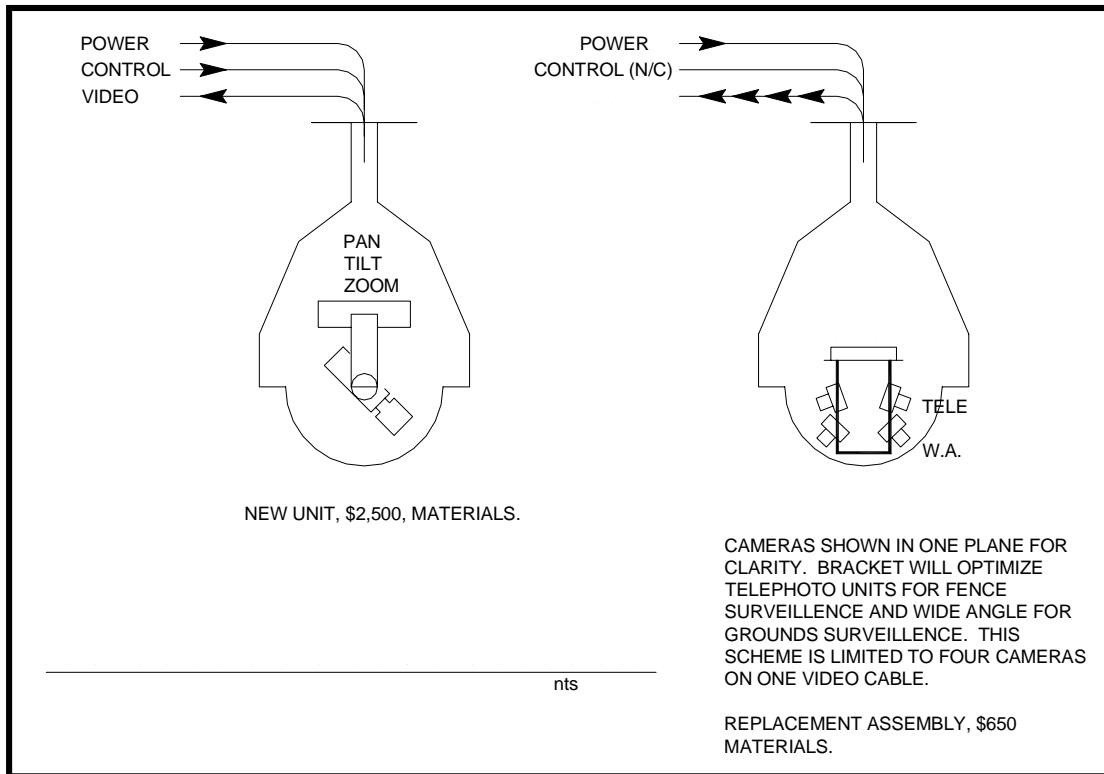

The many-camera large-dome above is based upon postage stamp cameras, available with telephoto varifocal lenses. Domes 9-in to 15-in can easily accept box cameras with longer telephoto lenses, as 7-70mm or 125mm. Four 3.6mm postage stamp cameras provide 360-degree coverage. More than four cameras cannot be handled by a quad multiplexer and probably justify multiple cables or a 6-camera IP-TV server. (Full-screen images are available from multiple cables or the IP-TV server.)

Postage stamp cameras can be manufactured in a tiny tubular weatherproof enclosure. They are called "bullet cameras." Low-end units cost slightly more than \$50 and varifocal lens units are available for \$350 to \$500. One is advertised as a "license plate camera" for gas stations. One is illustrated below.



CVC-550EX Color Low Light Cylinder Camera w/Varifocal Lens

The CVC-550EX is a weatherproof color bullet camera that features an auto iris 5~50mm varifocal lens and Super-HAD* technology. This camera boasts an ultra-high resolution picture, an adjustable varifocal lens and extreme low light sensitivity. With a steel grey weatherproof housing, and built-in heaters, this camera is suitable for indoor and outdoor applications. The mounting bracket protects the cable and is conduit compatible.

Features Include:

- Auto Iris 5-50mm varifocal lens
- Built-in heaters
- Turbo AGC
- Built-in back light compensation
- Pre-set auto exposure settings
- Non-condensing coated glass

Specifications:

- Resolution 480 lines
- Minimum Illumination 0.03 lux
- Image Device 1/3" Super-HAD* CCD
- Lens DC Auto Iris varifocal lens (5mm-50mm)
- Electronic Shutter 1/60 - 1/100,000 seconds
- Operating Temperature -14 degrees F to 122 degrees F
- Video S/N Ratio Greater than 50 dB
- Video Output 1.0 Vp-p 75 ohm
- Power Requirements Dual Voltage 24V AC/12v DC **[either/or]**
- Dimensions 11"L x 2.9"W x 2.7"H
- Weight 2.6 lbs.

CVC-550EX **\$433.00**

Fixed CCTV Camera Sound Supplied: Some cctv cameras are available with a built-in microphone. Three questions arise, 1) Should you use it? 2) How to use it? and 3) Is it legal? Regarding legality, please consult your legal counsel. There are federal wiretap and audio recording laws They are changed and re-interpreted frequently.

Should you monitor audio? Again, no answer from this course. There is a substantial sense of invasion of privacy associated with audio recording. It is not attached to video recording because the camera is visible. The goal of maintaining the goodwill of criminals in-the-act or

trespassers is not high priority. Maintaining the goodwill of employees, customers, guests and accused felons may be critical.

How to monitor audio is easy, but may be costly. Inexpensive standard intercom master stations which handle remote speakers may work without modification. If outboard speakers are installed adjacent to the camera, there is full compatibility with a \$100 intercom master and talkback is not a problem, probably a benefit.

If you want the microphone to provide a sound-sensing annunciation, the cost rises rapidly. Specialized security intercom masters start at \$10,000 and can be linked to stored pan, tilt, zoom settings for an observation camera or a camera switch selection.

Some IP-TV cameras are supplied with microphones and proprietary sound transmission schemes. Some have outboard sound adapters available.

Fixed CCTV Camera Color vs. Black-and-White: Color cameras work well but revert to black and white in low-light situations. Black and white cameras work very well but do not convey color information. Cost is very nearly the same. Color information may be very valuable. Identifying individual high school students, even in a group, is done by the clothing, not the facial features and cars in a parking lot, in transit or at a light are identified by color, not license plates. On the other hand, the wildlife that normally trip motion alarms on cameras covering open areas show up as well without color, and, in fact, alarming for an intruder works just as well without color. Black and white can deliver 525x600 without stretching the spec.

At one time, higher resolution was available in black and white than in color when staying in a limited price range. Today, the specs are very similar, probably favoring color, since more research and production development are done for color units.

There is a perception that low-cost black and white cameras do not last as long as high-end pan, tilt, zoom color cameras. This is not supported by statistics. A large urban school district in the snowbelt installed several thousand outdoor minidome black and white cameras without heaters and has experienced very, very low failure rates. On the other hand, some pan, tilt, zoom units have required service within two years.

Pan, Tilt, Zoom CCTV Camera Enclosure: Pan, tilt and zoom are modifications to the enclosure and lens. These will be discussed individually. Automatic controls will be addressed in the later controls section.

Pan, Tilt, Zoom CCTV Camera Pan: "Pan" refers to horizontal motion of the camera. The camera is always mounted in a horizontal plane, usually matching the Earth's horizontal plane. Therefore, a "pan" motion produces a rotation around the axis of the base. If the tilt is zero, exactly horizontal, then the image moves horizontally. If the tilt is down (expected) then the image moves in a cone towards the ground. This is intuitive from the joystick control on the camera, but is not a straight line in the plane of the ground. For any straight line path on the ground, the pan and tilt control will have to be continuously adjusted, or the object of interest will walk off the screen in an apparently diagonal path.

Regardless the practical limitations, "pan" means horizontal motion.

Pan, Tilt, Zoom CCTV Camera Tilt: "Tilt" refers to vertical motion of the camera, about a fixed horizontal axis. (Raising the camera while keeping a fixed orientation might also be called vertical motion, but it is not tilt.)

The problems with tilt are the sky and the sun. Objects seen against asphalt, concrete or grass have a reasonable contrast ratio. The image looks good. Objects seen against the sky have a contrast ratio beyond that which can be reproduced by the camera or the monitor. (When the problem shows up in still photography, it is called "backlighting" and white balance is adjusted to the point that the entire contrast ratio is used by the foreground object and the background "blooms" out.)

The automatic controls on a cctv camera will try to do this. If successful, you will see a momentary "bloom" as it adjusts. If not successful, you will see a blurry shadow against a nice image of the clouds and contrails.

If the installation permits panning above true horizontal, the image of the sun will form on the ccd sensor one day of the year. No more images will form on that part of the ccd, ever again. Depending upon the electronics, the camera may be self-protected so that it never reports an image ever again. This situation is catastrophic for a pan, tilt, zoom installation. It only occurs after gross negligence on a fixed camera installation.

Pan, Tilt, Zoom CCTV Camera Zoom: "Zoom lens" means changing from wide-angle to standard to telephoto without losing focus. It is a fairly complicated mechanical task, involving moving two internal lenses in opposite directions at different rates. Contrast this to "varifocal lens" which changes from wide-angle to standard to telephoto while losing focus with each change. For a fixed camera, no problem. For a continuously camera, big problem.

Zoom is complicated, expensive, guaranteed to fail and not very useful, but boy, is it fun to "ride the joystick". For remote control zoom to work you must communicate a zoom-in command, a neutral condition and a zoom-out command. This requires 3 wires from the control point to the camera location. A common workaround is to multiplex the zoom (and pan and tilt) on the video cable, called "down-the-coax". Multiplexers and de-multiplexers are expensive and there is no reason to believe that the part of the baseband (0-6MHz) where the control signals are hidden will not be filtered out by control devices from a different vendor. With digital processing becoming almost universal, special efforts must be made by the manufacturer to pass unused portions of the signal. The result is a system of pan, tilt, zoom control "over the co-ax" that works, but limits you to a single vendor or trust in alternate vendor's promises.

A complicated lens motion linkage and electric motor introduce a number of temperature-sensitive, limited-life components. The environmental controlled enclosure is recommended, to delay the guaranteed failure. As the components are internal to the zoom lens, you get to buy a new zoom lens, after you rent the man-lift. The flexible wiring or slip-rings between the de-multiplexer and the zoom drive have a reputation of failing, as well.

Real-world surveillance is not like entertainment drama programs. In fiction, the operator looks up and sees a full headshot of the perpetrator, standing still, looking into the camera, or wiping the knife on his pants. In the real world, the camera automatically pans and the operator must be watching at exactly the right moment to see something out of the ordinary. With motion sensing, a fixed camera, or pan, tilt, zoom camera at a fixed setting, alarms, so that the operator looks up. Advanced systems may be programmed to zoom into the motion sense target point to get a good look at the raccoon which has crossed the perimeter. (Operators commonly request that motion sensing be disabled.) Another alternative is linked

alarms. A microwave emitter/detector or PIR sensor alarms and the operator looks for the raccoon or the automatic devices zoom in on the raccoon.

The recommended alternative is four 90-degree (3.6mm fixed) cameras in the dome along with a quad multiplexer. There is no motion sickness in watching the screen and good information delivery is provided.

CCTV Camera Enclosure: Previously, recessed-ceiling enclosures and corner enclosures were popular. They are illustrated below:

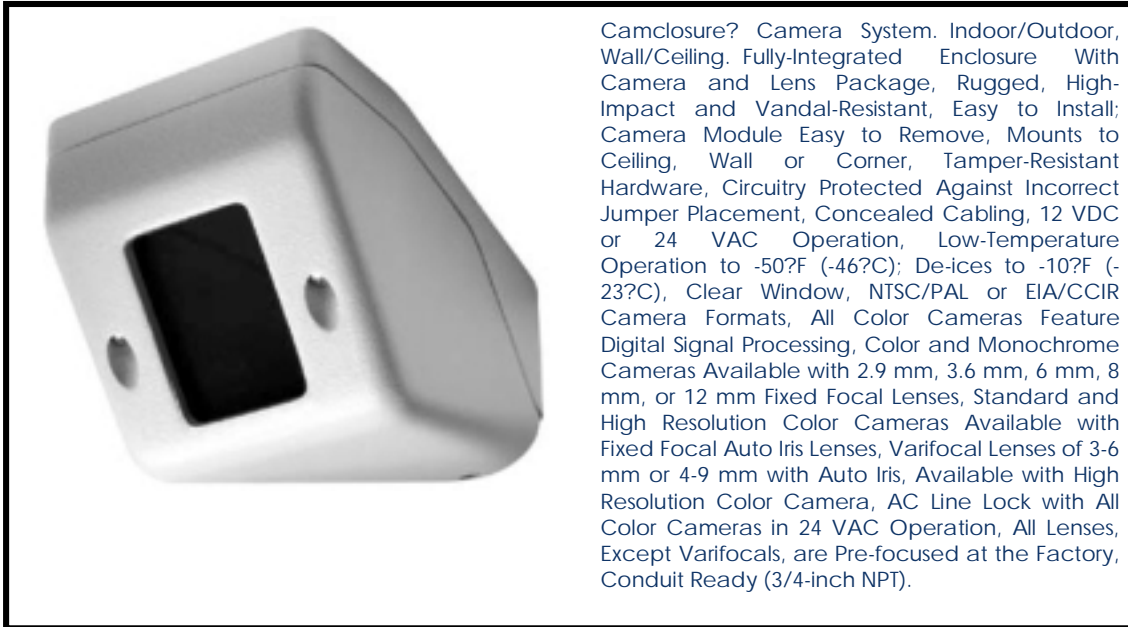

PRC-201C Recessed Ceiling Housing

Product Features

- Housing is manufactured from high impact white plastic, with viewing window manufactured from high grade optically clear acrylic
- Unit is fully adjustable for 360° positioning
- Metal back box for plenum applications to comply with standard building codes
- Designed for use in 2' x 2' suspended ceiling applications
- Units are sized for use with a fixed solid state 1/8" or 1/4" camera and lens combination
- Includes 26-gauge galvanized steel metal cover

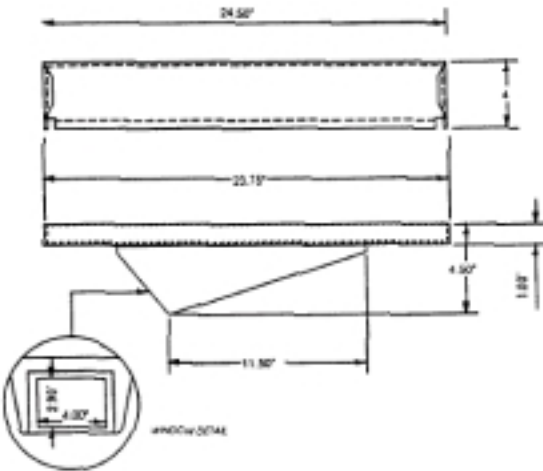

The PRC-201C housing is designed for use in suspended or sheet rock ceiling applications. Units are sized for use with a solid state 1/8" or 1/4" camera and lens combination. Housings are manufactured from 94HB flame rated plastic, with viewing windows manufactured from high impact optically clear acrylic. PRC-201C is fully adjustable for 360° positioning. Units Includes 26-gauge galvanized steel metal cover.



Pelco HS1500 / HS2000 Enclosure High Security, Indoor, Corner Mount HS-1500, HS-2000

Pelco HS1500 / HS2000 Enclosure High Security, Indoor, Corner Camera Mount
Pelco HS-2000 \$249.95



Pelco HS2100 High Security, Low Profile Ceiling Camera Mount

Pelco HS2100 High Security, Low Profile Ceiling Camera Mount
HS2100 \$89.95

Today, a minidome camera on the ceiling or wall is almost universal. Very rarely, a box camera on a bracket is installed and works for almost a week before vandalism. Available outdoor box and dome enclosures are illustrated below:



Pelco HS4514 Series Enclosure High Security, Outdoor, Bullet-Resistant HS-4514

Pelco HS4514 High Security, Outdoor, Bullet-Resistant Camera Housing
HS4514 \$589.95

EH3512/EH3515 Series Enclosure **OUTDOOR, SMALL**

Product Features

- Low Cost
- Small, Contemporary Design
- Die-Cast and Extruded Aluminum Construction
- Forward-Opening Hinged Lid
- Rear Lock-Latch
- Cable Entry Glands and Mounting Holes on Bottom of Enclosure
- Designed for Indoor/Outdoor Applications
- Easy Access for Servicing and Installation
- Models Available with Factory-Installed Low Power Heater, Blower and Defroster, or with Heater and Defroster



EH3512 ENCLOSURE WITH SUN SHIELD AND ENERGY MOUNT

Pelco 12-in Outdoor Enclosure, \$115.00



PIH-7625 Day/Night Color PTZ Camera with Outdoor Enclosure

PIH-7625 Day and Night Fast Dome Camera equips with a 25X optical zoom lens adopting Sony ExView CCD and retractable IR filter, automatically switch from high resolution color to high monochrome when light drops below 3 Lux. Additionally PIH-7625's on-screen menus offers easier and more configuration options such as: BLC zone selection, Auto White Balance mode selection, Zoom Speeds selection, Pictures Quality adjustment...Etc.

Skyway's Day and Night Fast Dome measures only 145mm in diameter and is capable of making 360 degrees continuous rotation with a speed range of 0.18 to 360 degrees per second, ensures direct and accurate target positioning. When required the dome can be quickly spun through 180 degrees, an important feature when something passes directly under the camera.

Up to 128 preset positions can be programmed and recalled with an accuracy of 0.25 degrees. First 16 presets can be divided into 4 groups for auto touring with individual settings for speed and dwell time.

Each Fast Dome has 6 alarm inputs (expandable to 64) can drive the dome to any position in under a second. A local alarm output can be configured as NO or NC and two types of alarm response mode provide flexible alarm management. RS-485 control interface makes our fast dome cameras easy to fit into our exist systems and compatible with other manufacturers' control systems.

- 480 TV lines of resolution.
- 1/4" CCD, 440,000 pixels (NTSC) for high quality images.
- Compact, lightweight and easy-to-use.
- High performance 25X power zoom.
- Wide angle photographic range.
- High-speed precision security camera head movement.
- Preset function with 12 preset positions that can be stored in the security camera's memory.
- RS-485 controllable.
- Features auto focus and auto white balance.
- Up to 24 security cameras can be controlled from 1 PC.
- COMPARE TO PELCO SPECTRA III
- UNBEATABLE PRICE PER PERFORMANCE

Digital Color - B/W Day / Night PTZ Camera

A great PTZ camera in an Outdoor Weatherproof Enclosure. Features 25X optical zoom, high speed 360° Pan and 110° Tilt and 128 presets. This Day/Night camera has excellent picture resolution, light sensitivity and will automatically switch from high resolution color to high monochrome when light drops below 3 Lux.

Model PIH-7625 NL (25x zoom) Price \$ 2,355.00

Analog Camera and Video Controls: Many, many years ago, camera gain and white balance were controlled remotely by an operator. The automatic controls are so good today

that they are built into the cameras and often not even available for set-up. Video controls here refers to display controls, including sequential switchers, quad multiplexers, loop-thru and termination and distribution amplifiers. These will be presented individually.

In this discussion, “analog camera” refers to the coaxial analog signal. The controls were formerly mechanical and electromechanical - as identified by the bright flash on the screen when switching. Today, almost all are electronic switches, with delay lines or digital storage to avoid flashes and picture roll when switching.

Analog Camera Video Sequential Switchers: A sequential switcher goes through a number of cameras in order. This permits one screen to display 4, 8 or more images in a sequence. Standard features and lock-out, (the sequence skips a selected camera, stop/continuous (select one camera alone) and adjustable dwell time (switching interval). Less common, but desirable features are loop-thru to take the signals from this monitoring station to a recorder or another monitoring station and multiple, isolated outputs. Also available is a control input so that an external alarm can switch the screen to the image containing the information. A typical unit is illustrated below:



**WJ-SQ208 8
INPUT
SEQUENTIAL
SWITCHER**

This 8 channel sequential switcher offers 8 camera inputs with loop-through outputs and adjustable dwell time. Additional features include sequence/spot switchable output. This unit will work with both color and black & white cameras.

Note that the functions of the sequential switcher are often included in a digital video recorder (DVR) or viewing software of an IP-TV system.

Analog Camera Video Quad Multiplexers: The literature often refers to these units as “quad splitters” because they split the monitor screen into four images from four cameras. Multiplexer is a better term because the device combines four signals into one output.

A large monitor with a quad replaces four small screens and with a switch permits selection of a single camera to fill the screen. There is a reduction in display resolution in the four-image mode. As with the sequential switcher, the quad function is often taken on by the DVR at the central location. A stand-alone quad is still very valuable for a remote or auxiliary monitoring site or when needs expand to four images, but there is no budget for three more video cables.

There is some similarity between the quad and the IP-TV camera server, but the quad loses image information and the camera server, arguably, does not. A quad is illustrated below:

Quads

A quad compresses images from up to 4 cameras and displays all of the images on a monitor's screen simultaneously. A quad eliminates the need to have multiple monitors. All 4 cameras can be viewed in quad format as well as individually. Each camera has a push button which brings that camera into full-screen view. The quad can be connected directly to a [time lapse recorder](#). During playback of the time lapse recorder's tape, the images will be displayed in the same manner they were recorded (WYSIWYG). In contrast to a [multiplexer](#), quads do not allow for full screen viewing of each camera during playback.



- Simultaneously monitor up to 8 color cameras
- Real-time Quad display (60 or 50 frames/sec)
- High resolution broadcast quality and 16 million true colors
- Option to watch a full screen or quadrant picture
- Built-in timer and title generator
- Auto sequential switching function and adjustable dwelling time (1-99 seconds)
- On screen video loss detection and alarm indicator
- Alarm input with built-in buzzer
- Independent brightness, contrast, color and tint adjustment for each channel
- Playback Zoom and Freeze function
- RS232 Remote Control
- User-friendly front panel design

S411 - Dual page quad, connect up to 8 color cameras \$390.00

Analog Camera Video Loop-Thru and Termination: This topic has been addressed several times within articles but is repeated here for ease of location, if needed.

Ideally, a 75-ohm camera feeds a 75-ohm cable which is connected to a 75-ohm monitor. In practice, this works well. However, it is common to have need for two monitors. This introduces an impedance mismatch and excessive loading. The problem goes away if the middle monitor is invisible. You make the monitor invisible by using a "bridging input".

A bridging input is a high impedance "tap" to the line that does not introduce load or reflections. High-end monitors, sequential switchers, quad multiplexers and other video control devices have a switch marked "Bridging / Terminating." The last device on the line should be terminating.

Less expensive equipment may have a termination switch but no output to assist looping the signal on to the next device. A BNC tee is used. One is illustrated below:



Analog Camera Video Distribution Amplifiers: In broadband CATV distribution, distribution amplifiers are used to boost signal level and provide isolation. This has not been commonly done with baseband cctv distribution. The reason is the differing system architectures. CATV has one source and many, many, many destinations, all of which are in operation concurrently.

CCTV has many sources and essentially, one destination. With the addition of redundant digital video recorders, pod and central control points and supervisor monitoring, this analysis becomes faulty. However, rather than invest in very complicated technology, distribution amplifiers and cross-bar switches, IT-TV uses the local area network the distribution system.

A data switch has the wonderful feature of store-and-forward. Six 100 Mbit lan branches, each containing six camera servers can feed a \$200 10100/1000 data switch which uplinks into the gigabit network interface on a \$1000 Compaq server. The server supports an outboard \$1000 terabyte RAID storage appliance. Also, \$2,000 plus software buys a fully redundant on-line server.

Analog Camera Video System Graphics: Many cctv designers grew up from audio visual (AV) system design. AV suppliers give the designers graphics packages with symbols and part numbers for proprietary devices. The designers can prepare a system design rapidly and have a bill of materials to price for their quotation. The results are very graphic, not very communicative system drawings.

A recommended alternative is to use boxes and labels. Not so pretty but much more communicative. Keyed notes (number in circle pointing to object; same number in circle with text on same page) further improve communications. Following are sample system graphics, then a fairly complex real-world video control system graphic:

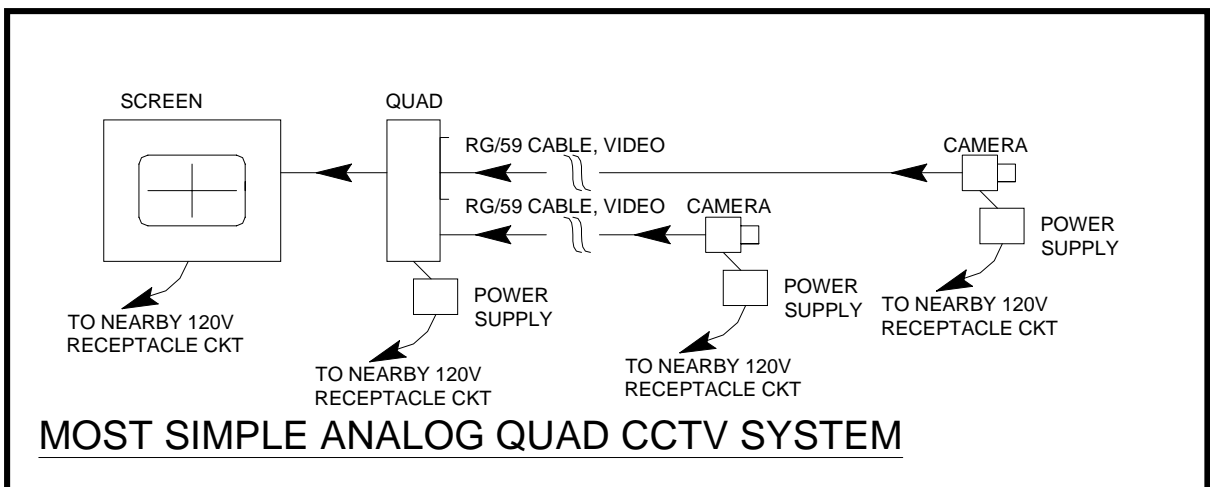
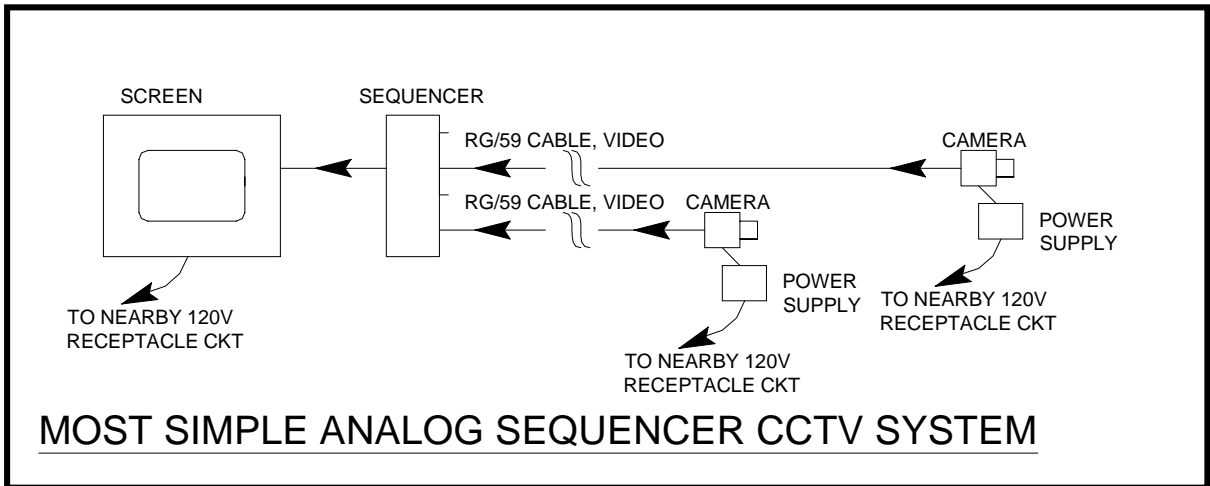
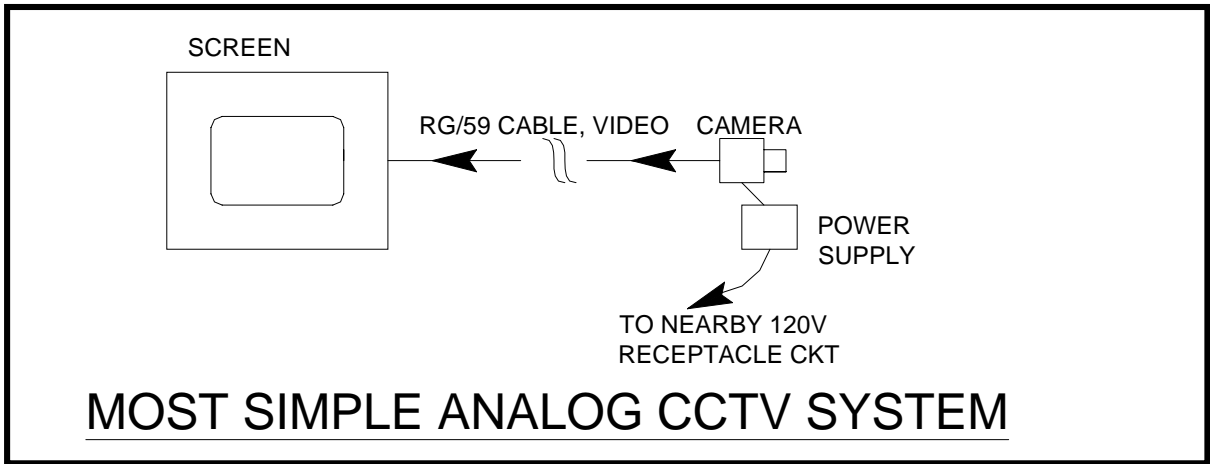

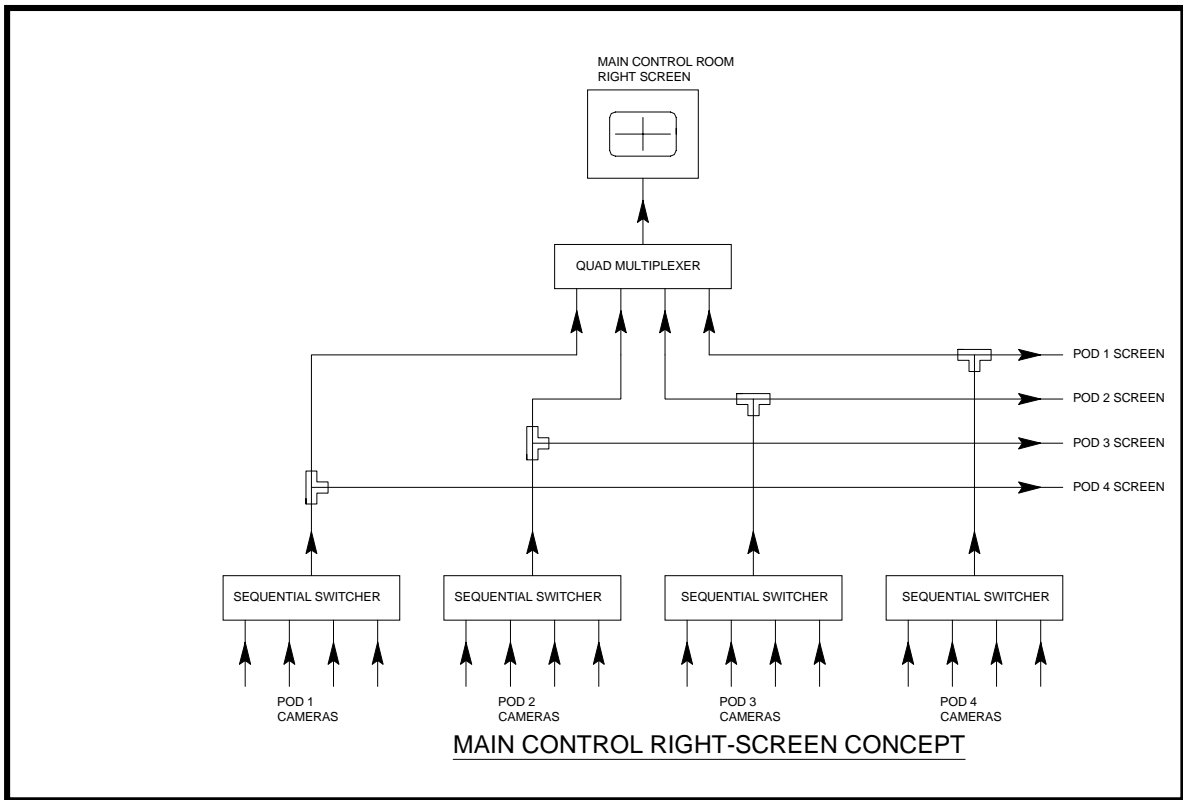
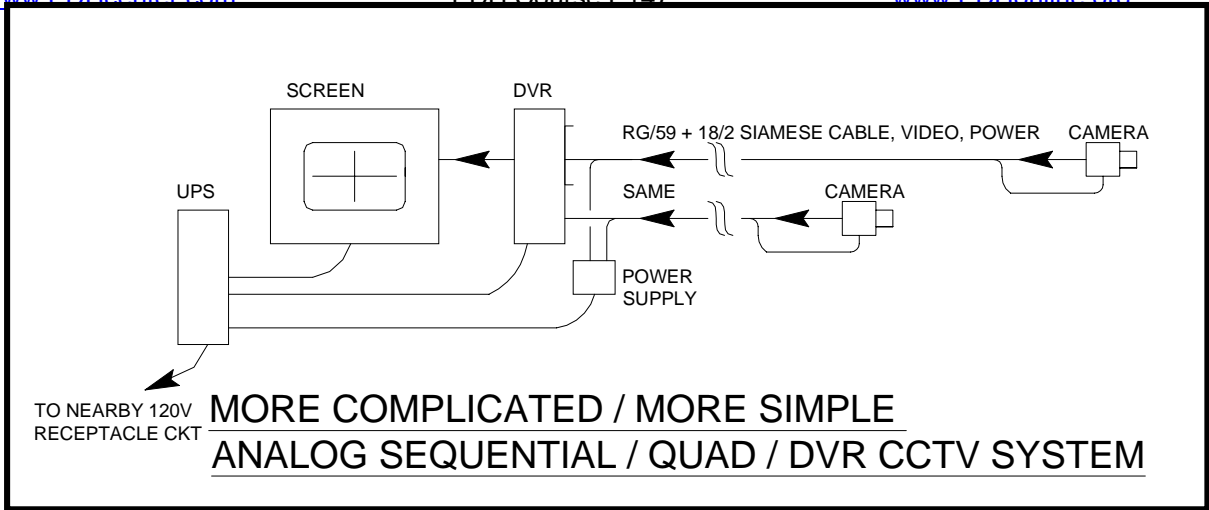

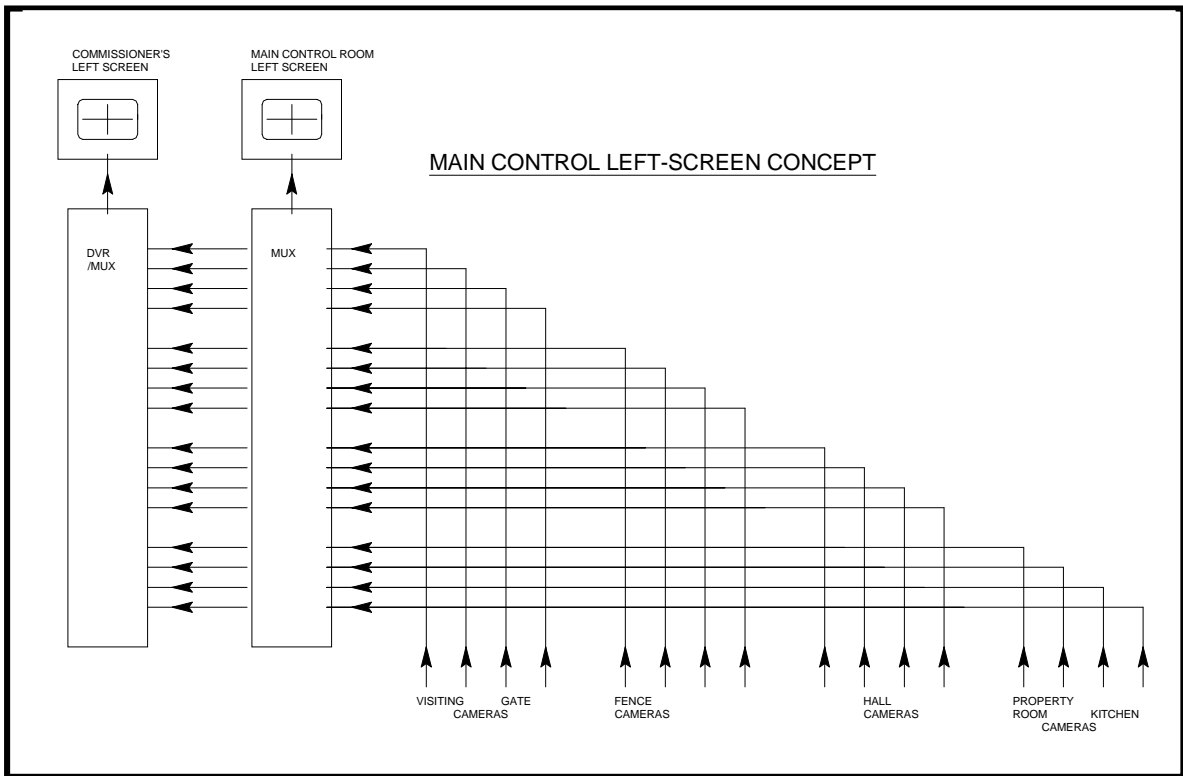
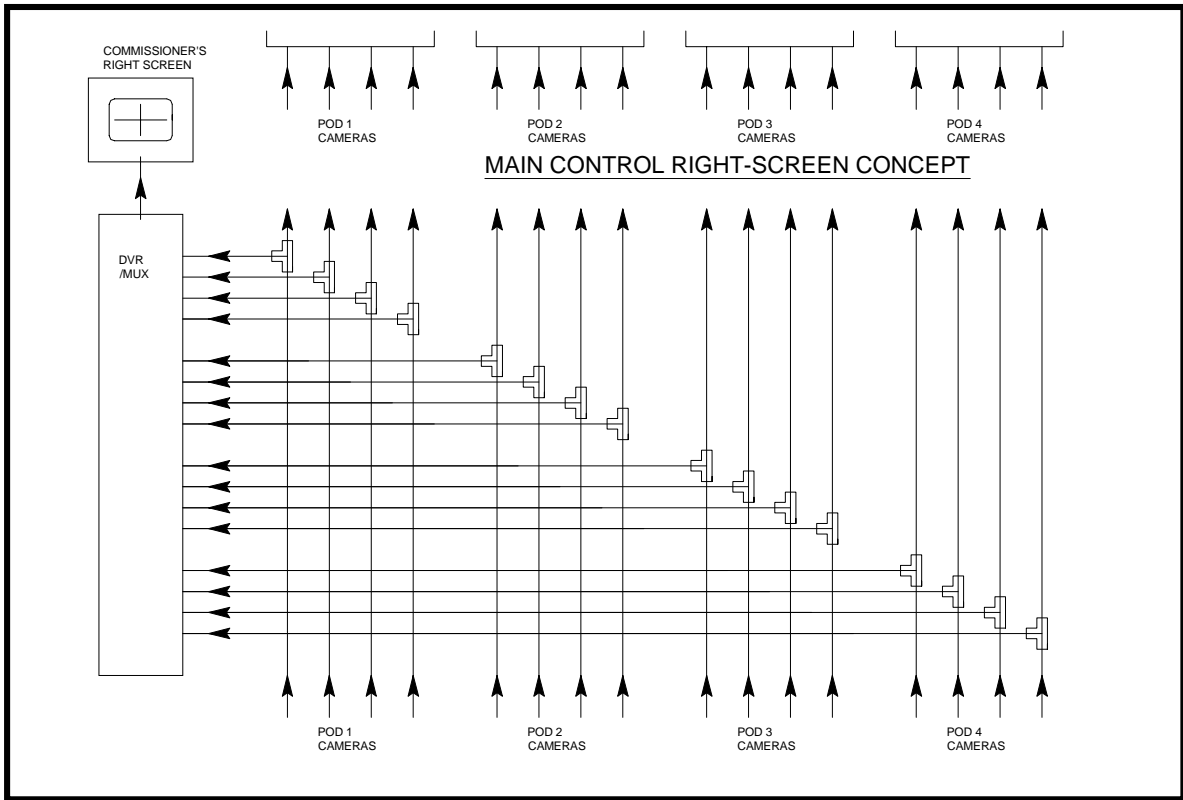

Analog Displays (Monitors): An analog display (Monitor) provides the picture to the user. Features of the picture which add to the cost are screen size, resolution, brightness, contrast ratio and viewing angle, enclosure and mounting. These will be discussed individually.

Analog Displays (Monitors) Screen Size: The key concept is that a cctv image is limited by the 525x300 resolution standard. When displayed on a 5x7 LCD screen in the back of a family van, it looks good. Because of the forgiveness of the human eye for moving pictures in entertainment, a 25-in (diagonal) home TV looks good. The image is not good. It is extremely grainy. Any size above 9-in (diagonal) may ease eyestrain, but does not improve the image.

Panasonic CCTV monitors are available in diagonal sizes of 5.6-in, 9-in, 13-in, 14-in, 15-in, 16-in, 17-in, 19-in, 20-in, 21-in. Panasonic is one of many good manufacturers and has a broad product line. Several are illustrated below:



WV-BM990 \$116.00

The Panasonic WV-BM990 9" diagonal black-and-white video monitor features a horizontal resolution of 800 lines. A unipotential picture tube with jet black background provides excellent contrast and sharp, highly detailed images



CBC 15" Color Monitor

The CBC America 14" monitor w/audio has 350 lines of resolution, 2 Video In, 2 Video Out (BNC), and is A/B switchable on front panel.

ZM-CR315NP-US \$270.00



Panasonic CT-L2000 20"LCD monitor

The Panasonic CT-L1400 LCD monitor provides clear crisp picture quality using Panasonics new LCD AI technology. Adaptive brightness intensifier technology boosts brightness and delivers deeper blacks in scenes with varying contract.

CT-L2000 \$1,229.00

In addition, 37-in, 42-in and 50-in plasma cctv monitors are available in the \$3,000 to \$10,000 price range. One demo of split-screen 16-images on a 42-in plasma display was very effective, but it used custom software and a personal computer, not analog cctv video.

Analog Displays (Monitors) Resolution: The input signal is 525x300, possibly 525x600 if bandwidth standards are exceeded. Nothing you can buy will produce images better than what the camera supplies.

If you buy a camera with 525x600 capabilities, make sure all video controls (switches, multiplexers, dvr) between it and the monitor will handle the excess bandwidth. Only then should you invest in a 525x600 monitor.

As an aside, color video has inherently less resolution than black and white. The 6MHz channel carries only luminance (white) information for black and white. The same 6MHz has to carry red, green and blue for the three guns on a color tube. The three are multiplexed into one by reducing the luminance, which is still sent for black and white screens. Red is reduced drastically, because the human eye is not very sensitive to red. The result is what you get.

Analog Displays (Monitors) Brightness: Brightness on a cathode ray tube (crt) monitor is a measure of the acceleration voltage of the electron gun and the efficiency of the screen phosphors. The technology is well advanced and it is rare to find much range in brightness among competing crt monitors. Measures are not usually quoted in product descriptions and appear in only a few of the detailed specification sheets.

Brightness is critical for LCD and plasma monitors. Rather, room ambient lighting and monitor mount are critical for LCD and plasma monitors. The brightness of these screens is much less than that of a crt. Yes, there is a range among manufacturers, but all are low values. Constructive recommendations include use of deep parabolic diffusers on overhead fluorescent lighting fixtures and carefully locating and tilting the monitors so that they do not reflect the lights into the operator's eyes.

Analog Displays (Monitors) Contrast Ratio and Viewing Angle: Contrast ratio and viewing angle are not meaningful for crt monitors. The contrast ratio is limited, but limited by the camera, not by the screen. A curved crt screen delivers poor images at extreme viewing angles, but it is usually not a problem.

Contrast ratio and viewing angle re critical for LDC screens. Current technology delivers 700:1 contrast ratio and better than 90-degree (45-degrees each way from center) viewing angle. Older technology delivered 500:1 contrast ratio or less and 10-degree viewing angle. The differences are striking in a side-by-side demonstration, but might not be prominent in literature or specifications.

There is no cost premium for current technology. Just avoid helping a vendor clear out old stock.

Analog Displays (Monitors) Enclosure and Mounting: The enclosure is the box around the monitor. Monitors are available without a box for rack mounting and home entertainment tv sets with video inputs with plastic boxes are commonly used as monitors. The commercial standard is a steel box, sometimes 14-gauge, called "Code Gauge". The question is, "How much abuse is expected?" The steel box is appropriate for a monitor on the receptionist's desk, used for temporary storage of delivered materials while the driver signs the log book. A home entertainment plastic box is very appropriate for a shelf of monitors in a security control room. Plastic boxes (bezels) on LCD screens are much more robust than the screens themselves.

Mounting is often an aesthetic preference decision. The result, however, affects the comfort and productivity of the operator for the life of the facility. Many security installations are 24/7, so this is a lot of hours of eyestrain and neck pain from a bad choice.

Three mountings are very common - loose desktop, sloping desk console and suspended overhead. Loose desktop location is very flexible, no custom cost, works well for crts and works very well for LCD screens. Cables can be handled by hanging them over the back of the desk, a 1-in hole in the desk or hanging over the front of the desk (not recommended). In terms of human factors, a loose desktop monitor is a very good choice, unless the lighting causes glare.

A low-rise sloping desk console permits direct visual contact over the top and works where windows or open space are behind the desk. In order to utilize larger screens, a low-rise console lets the screens "sink into" the writing space. The writing surface is essential, either 8-in for minimal use or 26-in for manuals and serious desk work. This is illustrated below. Custom wood consoles are sometimes fabricated and sometimes last more than 12-months before showing damage.

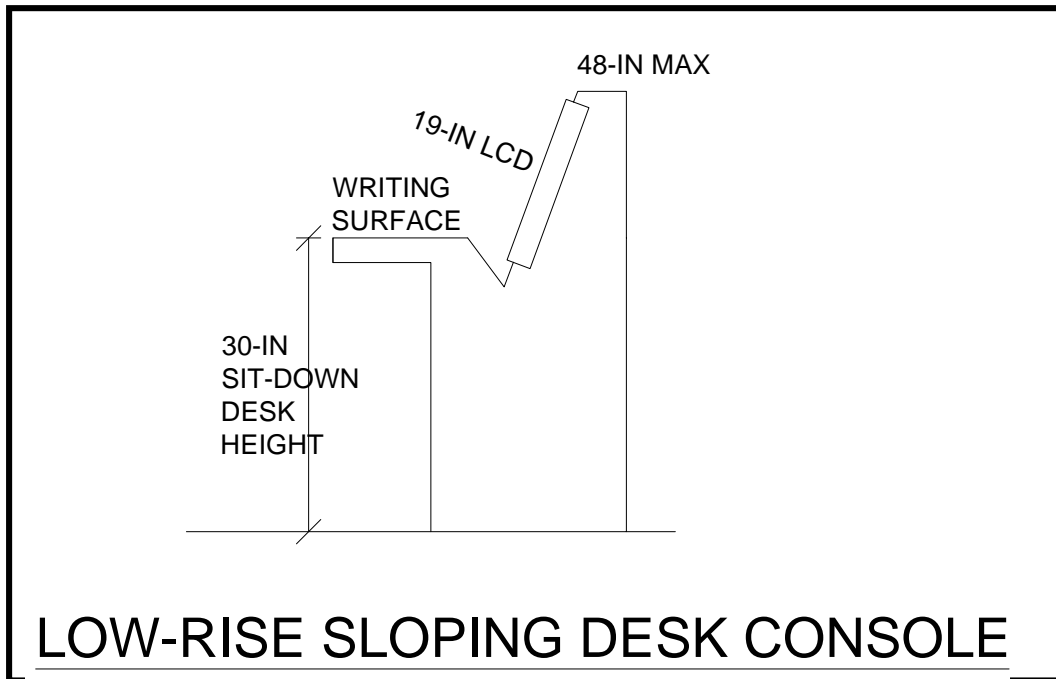

A high-rise sloping desk console is a monster. It overwhelms the proportions of the room and towers over the operator. If the writing surface is at 52-in, it is possible to see over the screens. A high-rise console with sit-down writing surface is illustrated below:



Analog Displays (Monitors) Video Projectors: Display via video projector is especially appropriate when used in conjunction with pan-tilt-zoom cameras and a joystick. They are all great toys.

Current technology video projectors deliver a very low brightness image. They are usable in a darkened room and windows must be heavily screened. (Reflective and non-reflective surface coatings are available in varying light densities.) Consumer grade projectors cost \$1,000 and use 1200 lumen lamps. Commercial grade projectors cost \$3,000 and use 2500 lumen lamps. The difference is just barely noticeable.

Lamps are rated to last four months in continuous duty, with a wide range among vendor offerings. Replacement lamps cost \$50 to \$200 each, or \$200 to \$800 per year.

A standard video image has 525x300 resolution; standard video projector resolution is 800x600, so specialized equipment is needed to display more than a 3x3 split-screen. A five-foot image will have pixels about 1/10-in apart. It will still look good from a distance.

Analog Storage (VCR): Over-the-air TV uses a 6 MHz channel. That corresponds to 12 megabits per second. The bandwidth and storage requirements can be reduced by diminishing the quality of the picture and the sound. 300 horizontal lines can be reduced to 200 or 100 lines. 20kHz sound can be reduced to 10kHz, 5kHz or eliminated entirely. Analog storage (or digital storage of analog signals) is defined by the resolution (bits per picture), compression (reduced bits per picture) and time-lapse interval (frames per second). The goal of all storage is minimum space (\$\$) per hour, day or month of storage. Analog and digital systems will be discussed at the same time and digital measures will be used for both. Several are illustrated below:



Panasonic AG-RT650 Time Lapse Recorder

The AG-RT650P features 8, 24, and 40- hour recording modes (with T160 tape), with Real Motion Time-Lapse recording in the 24 and 40 hour modes. This high-density recording assures playback images nearly as smooth as standard play VHS, a valuable feature for applications where precise image inspection is required.

AG-RT650P \$345.00



- **Converts analog video into digital format and records them on a removable hard disk drive**
- **Allows you to quickly access and search for specific time segments — no more scanning hours of videotape**
- **Recorded video can be viewed frame-by-frame**

Don't settle for recording long-term surveillance images on videotape. Record them digitally on a removable hard disk with these state-of-the-art digital video recorders from Lorex.

With the included 80GB hard drive, you'll be able to capture, manage or store up to 30 hours of real-time video, or an astounding 1,850 hours of time-lapse video. That amounts to nearly 80 days worth of round-the-clock video surveillance. Features include timer setting for easy searching, excellent recording quality, fast/slow forward and reverse searching, and many other user friendly operations.

Other features include:

- 30 Hour Real Time / 1850 Hour Recording (with 80 GB HDD)
- On Screen Display and Real Time Clock Function
- Quick Multiple Search Capability — by date, time, alarm, recording list
- 4 Adjustable Video Quality Settings
- 7 Selectable record settings
- Alarm, panic, repeat and timer options
- Emergency back up battery feature
- Fast / slow forward and reverse searching function
- Security password protection
- Supports 20-120 GB HDD
- Available with or without audio recording abilities

7768 1-CH DVR w/80G HARD DRIVE Price \$579.99



**DX9000 SERIES SYSTEM
(VIEWSTATION, RECORDER, STORAGE UNIT)**

Pelco DVR-DX9000 Digital Video Recorder has unlimited camera inputs and unlimited storage.

- 352x240 Resolution
- Individual Units Accommodate 8, 16, or 24 Camera Inputs at 30 Images per Second or 8, 16, 24, 32, or 40 Cameras at 15 Images per Second
- Instantaneous Playback of all Recorded Images
- Built-in Digital Motion Detection with Masking and Sensitivity Adjustments
- HDD RAID Arrays for Video Storage
- Continuous, Scheduled, or Event-Based Recording
- Easy Playback and Forward/Reverse Search

\$10,000+

Analog Storage (VCR) Resolution: The original IBM PC (1983) was available with a color graphics adapter (CGA) that delivered 320x240. It was pretty bad, but it drove a conventional video monitor or a TV thru a rf modulator. It was immediately supplanted by third-party video cards and higher resolution screens. IBM responded eventually with the VGA card at 640x480. This resolution is usable and is still widely used. This discussion is important because it reveals some of the compromises made by IBM - that we suffer from today in 360x240 storage resolution.

Broadcast TV contains non-image information in a few of the lines and suffers from raggedy edges on the sides. IBM saved money and avoided these problems by under-scanning the broadcast tv image. It clipped off the top, bottom and both sides. The image did not fill the screen, but all screens have height and width controls to use a smaller picture to fill the screen.

IBM threw away the edges and we can't have them back.

320x240 is considered standard resolution. 720x480 is available from some vendors, but, remember, there are only 525 lines and some of them are non-image. Obviously, more bits stored means fewer frames for a given piece of media. 320x240 = .08megapixels. 720x480 = .3megapixels. 4.5x the frames stored at the lower resolution.

Analog Storage (VCR) Compression: Time-lapse VHS recorders compress the image by saving only a few out of the continuous series. Modern technology permits selection of 1 frame every 10-seconds to 1 frame per second (fps) to 3 frames per second and up to 30 frames per second (no compression). 1 fps and 3 fps are standard security choices. 3 fps catches everything, but the subject may be turned away for the frame stored. 1 fps misses a lot, but is acceptable for large fields (can't get past the camera in 3-sec) or slow-changing events (stealing heavy items by manually).

The compression ratio provided by 3 fps is 10:1. The ratio for 1 fps is 30:1. The ratio for 1 frame every 10 seconds is 300:1. A full-speed VHS recorder should store one camera for something less than 30-hr at 1 fps. (Time-date stamping is important, and takes space. Also, it is common for engineers to include "guard bands" to prevent image overlap.) Changing tapes once per day is acceptable.

In addition to time-lapse compression, security VHS recorders use slow speed operation. Resolution is reduced but higher net compression ratios are produced. Resolution is also lost by reusing the tapes. Old tapes have noise and dropouts and reduced resolution.

Digital Storage (DVR) Compression: Digital video recorders can record analog information on digital storage devices or convert the information to digital format and record it on digital media. The time-date stamp problem is handled more easily by the digital conversion also with "watermarking". "Watermarking" is the term for fixing the data so it cannot be changed without notice. It is important for video to be used in court.

The joy of computers is that software can do anything you can imagine. It is easy to simulate time-lapse. .1 fps, 1 fps, 3 fps, 30 fps. No problem. Reduce resolution. Yes. Use image compression based upon the .jpg standard. Yes. Adjustable .jpg losses. Yes. There are also proprietary compression schemes that require a license for each machine, but they produce even higher net compression ratios.

Digital Storage (DVR) Summary Table: The .jpg compression ratio is determined, in part, by the amount of detail detected by the camera. A white wall should produce a small file. A crowd of people or a parking lot should create a large file. File sizes mentioned range from 5kB to 15kB for each frame. The following tables were created to relate file size, number of cameras and net compression to storage requirements. Key criteria were 1,000GB hard disk and 5GB standard density DVD. See the notes following the tables.

DVR Storage Requirements		15 kByte per frame				
		1 Camera	2	4	8	16 Cameras
no compression	1 fps					
	GB / hr	0.054	0.108	0.216	0.432	0.864
	GB / da	1.296	2.592	5.184	10.368	20.736
	GB / mo	38.88	77.76	155.52	311.04	622.08
50% compression	1 fps					
	GB / hr	0.027	0.054	0.108	0.216	0.432
	GB / da	0.648	1.296	2.592	5.184	10.368
	GB / mo	19.44	38.88	77.76	155.52	311.04
80% compression	1 fps					
	GB / hr	0.0108	0.0216	0.0432	0.0864	0.1728
	GB / da	0.2592	0.5184	1.0368	2.0736	4.1472
	GB / mo	7.776	15.552	31.104	62.208	124.416
90% compression	1 fps					
	GB / hr	0.0054	0.0108	0.0216	0.0432	0.0864
	GB / da	0.1296	0.2592	0.5184	1.0368	2.0736
	GB / mo	3.888	7.776	15.552	31.104	62.208
95% compression	1 fps					
	GB / hr	0.0027	0.0054	0.0108	0.0216	0.0432
	GB / da	0.0648	0.1296	0.2592	0.5184	1.0368
	GB / mo	1.944	3.888	7.776	15.552	31.104

		15 kByte per frame				
no compression	.3 fps					
	GB / hr	0.0162	0.0324	0.0648	0.1296	0.2592
	GB / da	0.3888	0.7776	1.5552	3.1104	6.2208
	GB / mo	11.664	23.328	46.656	93.312	186.624
50% compression	.3 fps					
	GB / hr	0.0081	0.0162	0.0324	0.0648	0.1296
	GB / da	0.1944	0.3888	0.7776	1.5552	3.1104
	GB / mo	5.832	11.664	23.328	46.656	93.312
80% compression	.3 fps					
	GB / hr	0.00324	0.00648	0.01296	0.02592	0.05184
	GB / da	0.07776	0.15552	0.31104	0.62208	1.24416
	GB / mo	2.3328	4.6656	9.3312	18.6624	37.3248
90% compression	.3 fps					
	GB / hr	0.00162	0.00324	0.00648	0.01296	0.02592
	GB / da	0.03888	0.07776	0.15552	0.31104	0.62208
	GB / mo	1.1664	2.3328	4.6656	9.3312	18.6624
95% compression	.3 fps					
	GB / hr	0.00081	0.00162	0.00324	0.00648	0.01296
	GB / da	0.01944	0.03888	0.07776	0.15552	0.31104
	GB / mo	0.5832	1.1664	2.3328	4.6656	9.3312

		7.5 kByte per frame				
		1 Camera	2	4	8	16 Cameras
no compression	1 fps					
	GB / hr	0.027	0.054	0.108	0.216	0.432
	GB / da	0.648	1.296	2.592	5.184	10.368
	GB / mo	19.44	38.88	77.76	155.52	311.04
50% compression	1 fps					
	GB / hr	0.0135	0.027	0.054	0.108	0.216
	GB / da	0.324	0.648	1.296	2.592	5.184
	GB / mo	9.72	19.44	38.88	77.76	155.52
80% compression	1 fps					
	GB / hr	0.0054	0.0108	0.0216	0.0432	0.0864
	GB / da	0.1296	0.2592	0.5184	1.0368	2.0736
	GB / mo	3.888	7.776	15.552	31.104	62.208
90% compression	1 fps					
	GB / hr	0.0027	0.0054	0.0108	0.0216	0.0432
	GB / da	0.0648	0.1296	0.2592	0.5184	1.0368
	GB / mo	1.944	3.888	7.776	15.552	31.104
95% compression	1 fps					
	GB / hr	0.00135	0.0027	0.0054	0.0108	0.0216
	GB / da	0.0324	0.0648	0.1296	0.2592	0.5184
	GB / mo	0.972	1.944	3.888	7.776	15.552

		7.5 kByte per frame				
no compression	.3 fps					
	GB / hr	0.0081	0.0162	0.0324	0.0648	0.1296
	GB / da	0.1944	0.3888	0.7776	1.5552	3.1104
	GB / mo	5.832	11.664	23.328	46.656	93.312
50% compression	.3 fps					
	GB / hr	0.00405	0.0081	0.0162	0.0324	0.0648
	GB / da	0.0972	0.1944	0.3888	0.7776	1.5552
	GB / mo	2.916	5.832	11.664	23.328	46.656
80% compression	.3 fps					
	GB / hr	0.00162	0.00324	0.00648	0.01296	0.02592
	GB / da	0.03888	0.07776	0.15552	0.31104	0.62208
	GB / mo	1.1664	2.3328	4.6656	9.3312	18.6624
90% compression	.3 fps					
	GB / hr	0.00081	0.00162	0.00324	0.00648	0.01296
	GB / da	0.01944	0.03888	0.07776	0.15552	0.31104
	GB / mo	0.5832	1.1664	2.3328	4.6656	9.3312
95% compression	.3 fps					
	GB / hr	0.00041	0.00081	0.00162	0.00324	0.00648
	GB / da	0.00972	0.01944	0.03888	0.07776	0.15552
	GB / mo	0.2916	0.5832	1.1664	2.3328	4.6656

Discussion:

This chart demonstrates the choices which permit one-month of video storage on a standard DVD.

Frame rate is under the control of the user. Record 1 frame per second (fps) and get acceptable security data - jerky, but nothing missed and good individual printed pictures.

Resolution is under limited control of the user. Camera selection and camera setup (and camera server setup) determine the native resolution of the video. The stored images, however, are .jpg, not native video. The jpeg compression is variable - a blank wall stores very few bytes. A parking lot stores many, many bytes. The fact that nothing changes from frame to frame does not reduce the size of a .jpg file (Other file formats use fewer bytes, but are not compatible with standard browsers.) 95% compression is possible indoors.

IP-TV (NetCam): For many years, remote construction sites have been visually monitored by TV cameras connected to phone lines back to the supervisor's office. Usually the images were saved on time-lapse video tape recorders. For some years, the technology used was dial-up or local area network (LAN) connection of a digital video camera that transmits by IP packets (standard LAN units) and is viewed on a personal computer (PC) web browser. Special software was available to record time-lapse pictures. The browser was used to view the stored pictures and the pc printer was used for paper copies. The early remote digital video cameras became known as NetCams when advertising websites included real-time pictures of the Golden Gate Bridge or San Francisco traffic intersections. Today they are widely used by day care centers, production control and security at factories and schools. The LAN can be the world-wide web or a set of cables just connecting the cameras with a DVR. The technology making up an IP-TV (NetCam) system includes the camera, the digital converter with adjustable compression, the camera server (IP converter), local area network, viewing pc's and recording software. These will be discussed below.

IP-TV (NetCam) Digital Camera / Integral Server: Data network terms are confusing. A server provides data to the user. The server is usually a box with many hard disks to hold the information and a software program to accept requests, authenticate that the user is permitted to received the data, then transmit the data. The user can have a simple browser, like Internet Explore or NetScape or a program, like WORD, that accepts the data into a document. For this discussion all of the above apply, except that the server is in the same box as the camera.

Axis, of Stockholmsborsen, Sweden, first commercialized the technology and today has about 75% of the market share. They offer excellent technical information and white papers, superb products, fair prices and research to expand the capabilities of the technology. US competitors have entered the market with good products, often identifying capabilities that Axis chose not to pursue. Inexpensive but impressive user software has been a US contribution.

An IP-TV (netcam) digital camera/integral server is a standard-size box camera which also contains a Unix processor and flash-RAM operating system. Retail price for the Axis 210 is less than \$300, including a fixed 3.6mm lens. Add a 5-50mm varifocal lens and this is an impressive tool. It does not have auto-iris and the instructions warn that it will be damaged by outdoor scenes (but it works very, very well if you stay away from the sun or reflections of the sun). The Axis 210 is pictured below:

AXIS 210 Network Camera

Superior video quality for professional indoor applications

The AXIS 210 Network Camera offers a cost-effective, IP-based solution for professional indoor security surveillance and remote monitoring. It delivers superior image quality using progressive scan and provides built-in motion detection and support for advanced event management.

The AXIS 210 delivers Motion JPEG images at up to 30 frames per second in all resolutions up to 640x480. It will also be able to provide both full frame rate Motion JPEG and MPEG-4 video streams simultaneously. Support for MPEG-4 will be offered as a free downloadable upgrade available in Q3 2004. MPEG-4 compression mode is ideal for applications where available bandwidth is restricted and higher frame rates are required.

The AXIS 210 connects directly to an IP network. With a built-in Web server, the AXIS 210 enables remote monitoring over a local area network or the Internet using a standard Web browser. Backed by the industry's largest base of application software for video and alarm management, the AXIS 210 is an ideal choice for securing offices, shops and other facilities.



The older Axis cameras, like the 210, support a standard browser and a \$100 Axis program to record the video and available audio. A range of third-party dvr software, from \$200 to \$1000 is available, simulating up to 10 100-camera sequential switcher, up to 16-camera quad, up to 30fps for all cameras and unlimited storage. A recent project utilized a Compaq lan server with gigabit communications, a terabyte of high-reliability storage, 100-camera capability and cost \$2500. It displays in real-time while recording while playing back stored images.

The newer cameras include high resolution (1600x1200) and high compression (200:1). They are more expensive and not so compatible with browsers and third-party dvr software. They answer specific needs, however.

IP-TV (NetCam) Camera Server: The better Axis integral server cameras grow rapidly in price. An economic choice is to use \$50 throw-away minidome cameras and an outboard multi-camera server. There are no perceivable differences between the operation of the integral camera server and the outboard multi-camera server. One is pictured below:

**Express 6™
VIDEO SERVER**

StarDot has introduced an affordable solution for monitoring multiple cameras sources over the Internet and local area networks. The **Express 6™ Video Server** is a small stand alone server that streams video from up to six video cameras that plug into the back of it. The Express 6 includes multiple network connections (1 x Ethernet and 2 x serial) and an MPEG/JPEG processor for streaming realtime video.

Because the Express 6™ Video Server is a stand alone solution, no PC is required in order for it to operate. This means lower cost and much higher reliability.



The image shows a white, rectangular, stand-alone video server. The front panel features a power button on the left, followed by an Ethernet port and two serial ports. The back panel has six BNC video input ports labeled VIDEO 1 through VIDEO 6, a green Ethernet port, and two additional serial ports.

IP-TV (NetCam) Local Area Network: For the prison surveillance project used in many examples in this course, a dedicated local area network was created. The capability of remote viewing over the internet was examined but not pursued at this time. If you build your own data network, you can avoid the IT department for a short time. Very inexpensive, works well.

The question remains, however, what is the effect on a business lan when you install one or more IT-TV cameras? Very informal tests demonstrated 30-user-session being fed from a single nebcam (all in house). After 30 sessions, significant frame loss took place and motion was noticeably jerky. No visible degradation up to 30, however. This test used a single lan connection on a single pc.

For the prison project, the question of lan loading was given to the video server vendor. His response follows:

I received the information regarding bandwidth. With the cameras set to 352 x 240 and a full load of 6 cameras per Express 6 you will get a frame rate of 1 fps. With 6 Express 6 devices configured this way, you will have a constant load on your switch of approximately 4-5Mbit/sec depending on the content of the images. If you increase the image size to 704 x 480, your frame rate will drop to 0.3 fps.

We also have a new DVR software that is not yet advertised on our web site that will record up to 100 cameras at once and view up to 16 cameras at a time. This software is \$495. This may assist you in the small question you have regarding your number of cameras.

Approximate Frame Rates =

352 x 240:

MPEG-1 Single Camera = 30 fps

JPEG Server Push:

x 1 camera = 10 fps
x 2 camera = 3 fps
x 3 camera = 2 fps
x 4 camera = 1.5 fps
x 5 camera = 1.2 fps
x 6 camera = 1 fps

702 x 480:

JPEG Server Push:
x 1 camera = 2.9 fps
x 2 camera = 0.9 fps
x 3 camera = 0.6 fps
x 4 camera = 0.5 fps
x 5 camera = 0.4 fps
x 6 camera = 0.3 fps

I hope this addresses all of your current questions regarding bandwidth. Essentially, since each of the Express 6 devices operate independently, you may run as many as you want. You could put an Express 6 server on every port of the 24 port switch (Which we sell for \$107/125 depending on the D-Link model you desire) and never come close to the bandwidth capacity of the switch. The fully loaded switch would only be transferring sustained a maximum of 20Mbit/sec

IP-TV (NetCam) Viewing PC: The personal computer used for viewing the netcam is non-critical. The oldest 2.88MHz pc will do fine. Any pc since Windows98 will be able to view in foreground and perform all normal tasks in background. Swap foreground and background at will, no conflicts, no slow-downs, no lock-ups from the browser and camera.

IP-TV (NetCam) System: The following illustration shows one version of the final prison IP-TV design:

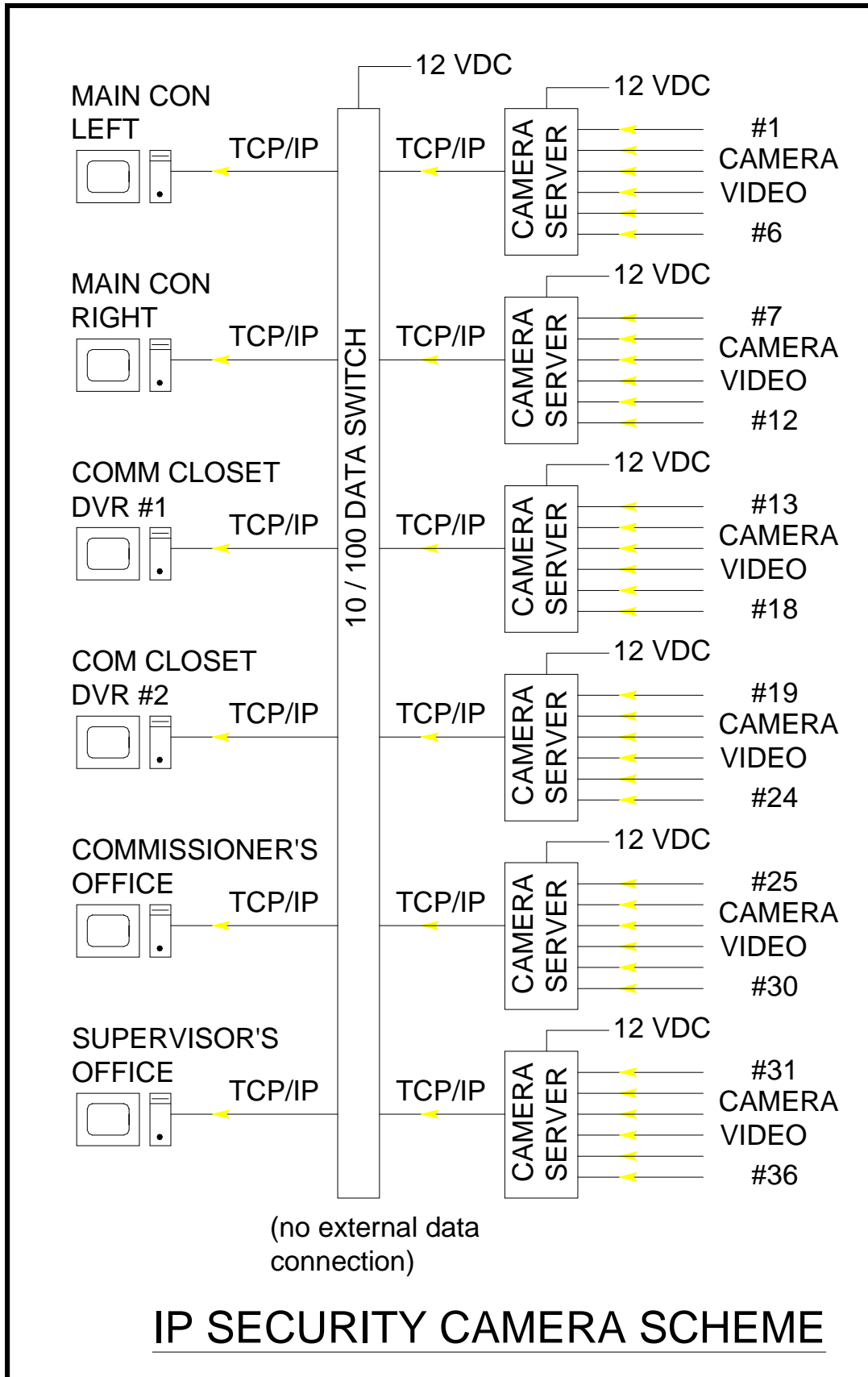

Obvious and Subtle Errors in CCTV Design: The most critical elements in producing a quality cctv image are camera location, lens selection and lighting. These three components deserve almost as much attention as the rest of the design. It is well worth the time to do a site visit with a cctv camera with varifocal lens and a laptop computer that accepts video input. Record screen shots (Alt-PrtSc --> Microsoft Word Ctl C). Make sure the designer and the Client are satisfied with the images.

Camera location can be changed by relocating the mounting bracket and using a different style of bracket. A 10-ft pendant mount may have aesthetic drawbacks, but may be the only way to get an acceptable image.

Lens selection is covered in the course. A 5mm to 50mm varifocal lens covers standard lenses and moderate telephoto lenses. If a long telephoto lens may be required, take along a 7mm to 70mm varifocal or a 125mm fixed. Each of these costs about \$100 and may be permanently installed after the desired image is obtained.

Lighting is a terrible problem. Not technically, but with the content provider(s). You can always get a good cctv image by placing a spotlight next to the camera, aimed at the presenter. (There is an excellent PDH course on theatrical lighting design.) Unfortunately, amateur presenters refuse to perform with a bright spotlight in their eyes.

A compromise is two bright spotlights at the far left and far right of the back of the space. These, again, provide excellent lighting of the presenter and excellent images, but are not in the same line-of-sight as the audience. Two lights, in locations not under the control of the tv person have a low likelihood of remaining on and aimed correctly.

Subtle design errors include inadequate specification of cable installation. The National Electric Code is clear on proper installation. (This is covered, with examples, in the course.) Local inspectors are becoming sensitive to the fire hazard of loose cables blocking access to the above-ceiling space and contributing to toxic smoke levels. It is a major hardship for the contractor to re-pull all cables as a result of final electrical inspection.

A very subtle hazard is unsatisfactory interaction of video electronics by different manufacturers. A video consultant will take responsibility for compatibility - and usually specify only one manufacturer. A lighting designer who is covering for video needs on a job may see substantial savings from selecting components from different manufacturers. Savings, yes; potential for incompatibility, yes, again. This is because digital handling of analog signals makes certain assumptions about the analog signals. Another digital component may have modified those signal characteristics. See the discussion of down-the-coax control of pan-tilt-zoom cameras in the course material.

Be careful with counts and maximum cable lengths. Common input counts for sequential switches, quad multiplexers and digital video recorders are 4 cameras, 8 cameras and 16 cameras. The 17th camera can be a real problem. A quad multiplexer upstream of the dvr is a work-around, but it looks like a work-around.

A commonly used set of maximum video cable lengths follows:

TYPE OF CCOAXIAL CABLE	RECOMMENDED MAXIMUM COAXIAL CABLE LENGTH	CABLE DIAMETER
RG59/U	750 FEET	0.25 INCHES
RG6/U	1500 FEET	0.28 INCHES
RG11/U	1800 FEET	0.404 INCHES

The installer must provide connectors that fit the cable diameter. This is normally a “means and methods” question for the contractor, not a design decision. It points out, however, the hazard of the designer taking on too much responsibility.

There are also limits on the power cable length for the camera. The variables are camera load in amperes, the tolerable voltage drop and the power wire size. Cameras work well on #22 AWG within 20-ft of the power supply. #18 AWG is the standard siamese cable power conductor size (see text). #10 AWG is a common power conductor for long lighting and receptacle circuits. It is unlikely that camera mis-operation will result from #18 AWG power runs under 1000 feet. The calculations are worthwhile if any questions arise or if enclosure heaters are being sourced by the same cable.

Camera Power Wire Size Determination									
(resistance ohms/meter	0.0515	0.0324	0.0204	0.0128	0.00806	0.00507	0.00319		
(resistance per 1000-ft)			25.8	16.2	10.2	6.6	3.9		
		Wire Size							
va	amps at 12VDC	22	20	18	16	14	12	10	
500	41.7	0	0	0	1	1	1	2	
300	25.0	0	1	1	2	3	3	6	
250	20.8	0	1	1	2	4	4	9	
200	16.7	0	1	2	4	6	6	14	
150	12.5	0	3	4	6	10	10	26	
100	8.3	0	6	9	14	23	24	58	
80	6.7	0	9	14	22	36	37	90	
60	5.0	1	16	25	40	63	66	160	
40	3.3	5	35	56	90	143	148	360	
30	2.5	24	63	100	159	254	262	640	
20	1.7	89	142	226	358	571	591	1440	
10	0.8	178	283	451	716	1142	1181	2880	

Permissible Camera Cable Length, feet, per
<ftp://www.pelco.com/ProductManuals/C1981MC.PDF>

The final concern is vandalism. Unfortunately, there are destructive persons around. Cameras are perceived as intrusive and often unwelcome. A minidome camera with concealed wiring should survive most attacks. An exposed box camera mounted less than 10-ft above finished floor will almost certainly be re-aimed, the lens removed or disappear entirely.