



**PDHonline Course G183 (4 PDH)**

---

## **Building Insulation Basics**

*Instructor: Helen Chen, Ph.D., PE*

**2020**

**PDH Online | PDH Center**

5272 Meadow Estates Drive  
Fairfax, VA 22030-6658  
Phone: 703-988-0088  
[www.PDHonline.com](http://www.PDHonline.com)

An Approved Continuing Education Provider



# Insulation Fact Sheet

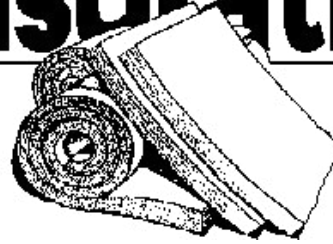

DOE/CE-0180, 2011

**Department of Energy**

Assistant Secretary

Energy Efficiency and Renewable Energy

## Contents

### Introduction

- Why Insulate Your House?
- How Insulation Works

### Which Kind of Insulation is Best?

- What Is an R-Value?
- Reading the Label
- Insulation Product Types

### Insulating a New House

- Where and How Much
- Air Sealing
- Moisture Control and Ventilation
- Installation Issues
  - Precautions
  - Attics
  - Walls
- Design Options
  - Crawlspace and Slabs
  - Advanced Wall Framing
  - Metal Framing
  - Insulating Concrete Forms
  - Massive Walls
  - Structural Insulated Panels
  - External Insulation Finish System
  - Attic Ventilation or a Cathedralized Attic

### Adding Insulation to an Existing House

- Where and How Much
- How Much Insulation Do I Already Have?
- Air Sealing
- Moisture Control and Ventilation
- Insulation Installation, the Retrofit Challenge
  - Precautions
  - Attics
  - Walls
  - Basement Walls
  - Floors and Crawlspace

### Resources and Links

### Appendix – Related Technology Fact Sheets

- Ceiling and Attics
- Attics Access
- Wall Insulation
- Basement Insulation
- Crawlspace Insulation
- Slab Insulation
- Air Sealing
- Whole-House Ventilation Systems

## Introduction

### Why Insulate Your House?

Heating and cooling account for 50 to 70% of the energy used in the average American home. Inadequate insulation and air leakage are leading causes of energy waste in most homes.

Insulation:

- saves money and our nation's limited energy resources
- makes your house more comfortable by helping to maintain a uniform temperature throughout the house, and
- makes walls, ceilings, and floors warmer in the winter and cooler in the summer.

The amount of energy you conserve will depend on several factors: your local climate; the size, shape, and construction of your house; the living habits of your family; the type and efficiency of the heating and cooling systems; and the fuel you use. Once the energy savings have paid for the installation cost, energy conserved is money saved - and saving energy will be even more important as utility rates go up.

This fact sheet will help you to understand how insulation works, what different types of insulation are available, and how much insulation makes sense for your climate. There are many other things you can do to conserve energy in your home as well. The Department of Energy offers many **web sites** to help you save energy by sealing air leaks, selecting more energy-efficient appliances, etc.

### How Insulation Works

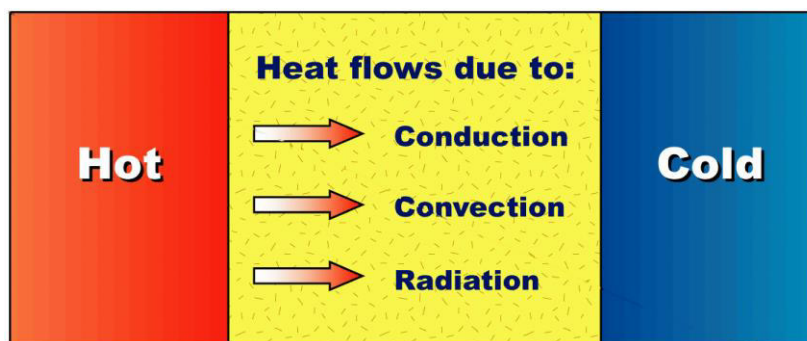

Heat flows naturally from a warmer to a cooler space. In winter, the heat moves directly from all heated living spaces to the outdoors and to adjacent unheated attics, garages, and basements - wherever there is a difference in temperature. During the summer, heat moves from outdoors to the house interior. To maintain comfort, the heat lost in winter must be replaced by your heating system and the heat gained in summer must be removed by your air conditioner. Insulating ceilings, walls, and floors decreases the heating or cooling needed by providing an effective resistance to the flow of heat.

Batts, blankets, loose fill, and low-density foams all work by limiting air movement. (These products may be more familiarly called fiberglass, cellulose, polycynene, and expanded polystyrene.) The still air is an effective insulator because it eliminates convection and has low conduction. Some foams, such as polyisocyanurate, polyurethane, and extruded polystyrene, are filled with special gases that provide additional resistance to heat flow.

Reflective insulation works by reducing the amount of energy that travels in the form of radiation. Some forms of reflective insulation also divide a space up into small regions to reduce air movement, or convection, but not to the same extent as batts, blankets, loose-fill, and foam.

## Which Kind of Insulation Is Best?

Based on our email, this is one of the most popular questions homeowners ask before buying insulation. The answer is that the *'best'* type of insulation depends on:

- how much insulation is needed,
- the accessibility of the insulation location,
- the space available for the insulation,
- local availability and price of insulation, and
- other considerations unique to each purchaser.

Whenever you compare insulation products, it is critical that you base your comparison on equal R-values.

### What Is an R-Value?

Insulation is rated in terms of thermal resistance, called R-value, which indicates the resistance to heat flow. ***The higher the R-value, the greater the insulating effectiveness.*** The R-value of thermal insulation depends on the type of material, its thickness, and its density. In calculating the R-value of a multi-layered installation, the R-values of the individual layers are added.

The effectiveness of an insulated ceiling, wall or floor depends on how and where the insulation is installed.

- Insulation which is compressed will not give you its full rated R-value. This can happen if you add denser insulation on top of lighter insulation in an attic. It also happens if you place batts rated for one thickness into a thinner cavity, such as placing R-19 insulation rated for 6¼ inches into a 5½ inch wall cavity.
- Insulation placed *between* joists, rafters, and studs does not retard heat flow through those joists or studs. This heat flow is called thermal bridging. So, the overall R-value of a wall or ceiling will be somewhat different from the R-value of the insulation itself. That is why it is important that attic insulation cover the tops of the joists and that is also why we often recommend the use of insulative sheathing on walls. The short-circuiting through metal framing is much greater than that through wood-framed walls; sometimes the insulated metal wall's overall R-value can be as low as half the insulation's R-value.

### Reading the Label

No matter what kind of insulation you buy, check the information on the product label to make sure that the product is suitable for the intended application. To protect consumers, the Federal

Trade Commission has very clear rules about the R-value label that must be placed on all residential insulation products, whether they are installed by professionals, or whether they are purchased at a local supply store. These labels include a clearly stated R-value and information about health, safety, and fire-hazard issues. Take time to read the label BEFORE installing the insulation. Insist that any contractor installing insulation provide the product labels from EACH package (which will also tell you how many packages were used). Many special products have been developed to give higher R-values with less thickness. On the other hand, some materials require a greater initial thickness to offset eventual settling or to ensure that you get the rated R-value under a range of temperature conditions.

### Insulation Product Types

Some types of insulation require professional installation, and others you can install yourself. You should consider the several forms of insulation available, their R-values, and the thickness needed. The type of insulation you use will be determined by the nature of the spaces in the house that you plan to insulate. For example, since you cannot conveniently "pour" insulation into an overhead space, blankets, spray-foam, board products, or reflective systems are used between the joists of an unfinished basement ceiling. The most economical way to fill closed cavities in finished walls is with blown-in insulation applied with pneumatic equipment or with sprayed-in-place foam insulation.

The different forms of insulation can be used together. For example, you can add batt or roll insulation over loose-fill insulation, or vice-versa. Usually, material of higher density (weight per unit volume) should not be placed on top of lower density insulation that is easily compressed. Doing so will reduce the thickness of the material underneath and thereby lower its R-value. There is one exception to this general rule: When attic temperatures drop below 0°F, some low-density, fiberglass, loose-fill insulation installations may allow air to circulate between the top of your ceiling and the attic, decreasing the effectiveness of the insulation. You can eliminate this air circulation by covering the low-density, loose-fill insulation with a blanket insulation product or with a higher density loose-fill insulation.

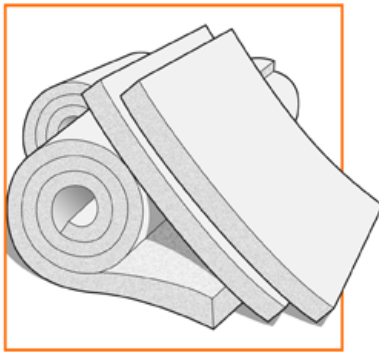

ORNL 07-021658/60h

Blankets, in the form of batts or rolls, are flexible products made from mineral fibers, including fiberglass or rock wool. They are available in widths suited to standard spacings of wall studs and attic or floor joists. They must be hand-cut and trimmed to fit wherever the joist spacing is non-standard (such as near windows, doors, or corners), or where there are obstructions in the walls (such as wires, electrical outlet boxes, or pipes). Batt's can be installed by homeowners or professionals. They are available with or without vapor-retarder facings. Batt's with a special flame-resistant facing are available in various widths for basement walls where the insulation will be left exposed.

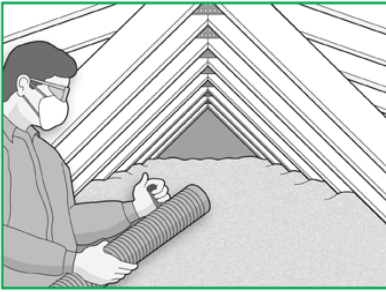

**Blown-in loose-fill** insulation includes cellulose, fiberglass, or rock wool in the form of loose fibers or fiber pellets that are blown using pneumatic equipment, usually by professional installers. This form of insulation can be used in wall cavities. It is also appropriate for unfinished attic floors, for irregularly shaped areas, and for filling in around obstructions.

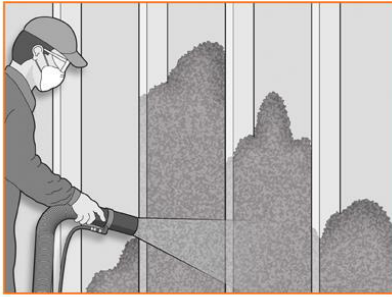

In the open wall cavities of a new house, cellulose and fiberglass fibers can also be sprayed after mixing the fibers with an adhesive or foam to make them resistant to settling.



**Foam insulation** can be applied by a professional using special equipment to meter, mix, and spray the foam into place. Polyisocyanurate and polyurethane foam insulation can be produced in two forms: open-cell and closed-cell. In general, open-celled foam allows water vapor to move through the material more easily than closed-cell foam. However, open-celled foams usually have a lower R-value for a given thickness compared to closed-cell foams. So, some of the closed-cell foams are able to provide a greater R-value where space is limited.

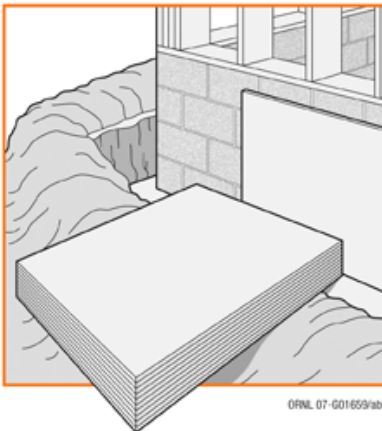

**Rigid insulation** is made from fibrous materials or plastic foams and is produced in board-like forms and molded pipe coverings. These provide full coverage with few heat loss paths and are often able to provide a greater R-value where space is limited. Such boards may be faced with a reflective foil that reduces heat flow when next to an air space. Rigid insulation is often used for foundations and as an insulative wall sheathing.

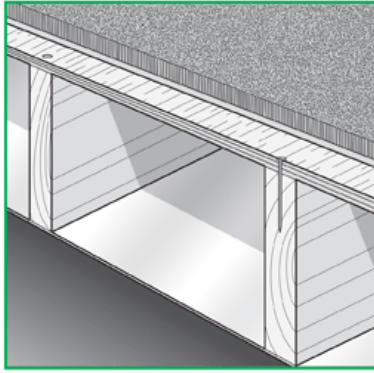

ORNL 07-001650/ahh

Reflective insulation systems are fabricated from aluminum foils with a variety of backings such as kraft paper, plastic film, polyethylene bubbles, or cardboard. The resistance to heat flow depends on the heat flow direction, and this type of insulation is most effective in reducing downward heat flow. Reflective systems are typically located between roof rafters, floor joists, or wall studs. If a single reflective surface is used alone and faces an open space, such as an attic, it is called a radiant barrier.

Radiant barriers are installed in buildings to reduce summer heat gain and winter heat loss. In new buildings, you can select foil-faced wood products for your roof sheathing (installed with the foil facing down into the attic) or other locations to provide the radiant barrier as an integral part of the structure. For existing buildings, the radiant barrier is typically fastened across the bottom of joists, as shown in this drawing. All radiant barriers must have a low emittance (0.1 or less) and high reflectance (0.9 or more).

## Insulating a New House (Do It Right the First Time)

If you are buying or building a new house, make sure that energy-saving features are included. The Federal Trade Commission (FTC) home insulation rule requires the seller of a new home to provide information on the type, thickness, and R-value of the insulation that will be installed in each part of the house in every sales contract. Many state or local building codes include minimum requirements for home insulation. Be sure that your new home or home addition meets these building codes. You may wish to install insulation beyond the minimum specified in such codes, especially if those minimum levels are below those recommended here. Also, Energy-Efficient Mortgages are available through both government-insured and conventional loan programs. These mortgages recognize that the homeowner's energy payments will be less for a more energy-efficient home, and therefore enable a buyer to borrow a larger sum to cover the up-front costs of improving the house's energy efficiency.

To keep initial selling prices competitive, many home builders offer standard (not optimal) levels of insulation, although additional insulation would be a good investment for the buyer. Builders participating in the Energy Star Program use third-party inspectors to not only ensure that the correct amount of insulation has been used, but also to ensure that it has been installed correctly.

*It is always more economical to install the recommended levels of insulation during initial construction rather than adding insulation later. Many insulation locations are enclosed during the construction process and it is very difficult to add insulation to these locations at a later time.*

Now is also the time to make your home air tight. Special products and techniques are available to eliminate air leaks between the walls and floor and between the walls and ceiling. Encourage your builder to make all clearances around doors and windows as tight as possible and to properly caulk and seal all such joints.

### Where and How Much?

Figure 1 on next page shows which building spaces should be insulated. Discuss the house plans with your builder, and make sure each of these spaces is properly insulated to the R-values recommended here. Remember to buy the insulation based on this R-value, and to check the product label to determine the insulation's proper thickness, especially if you plan to install it in a confined space, such as in wall cavities and cathedral ceilings.



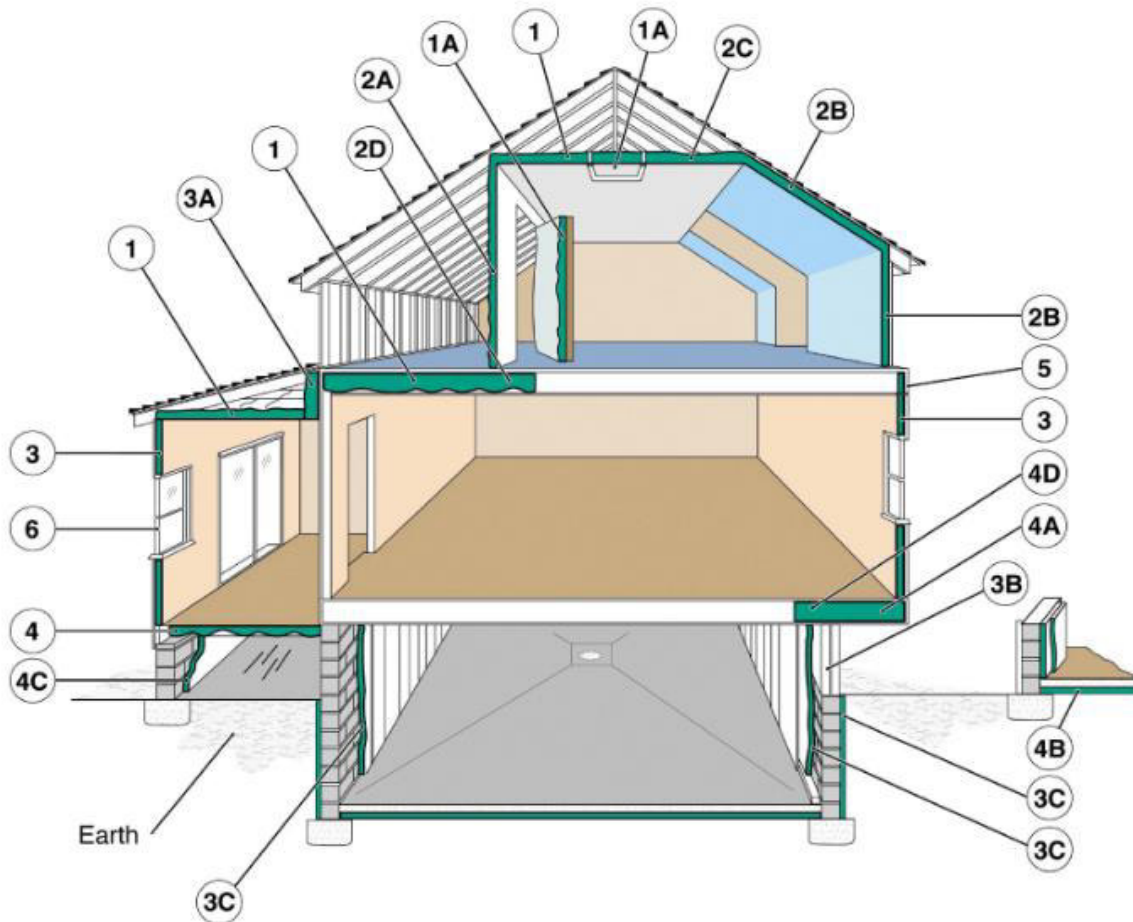
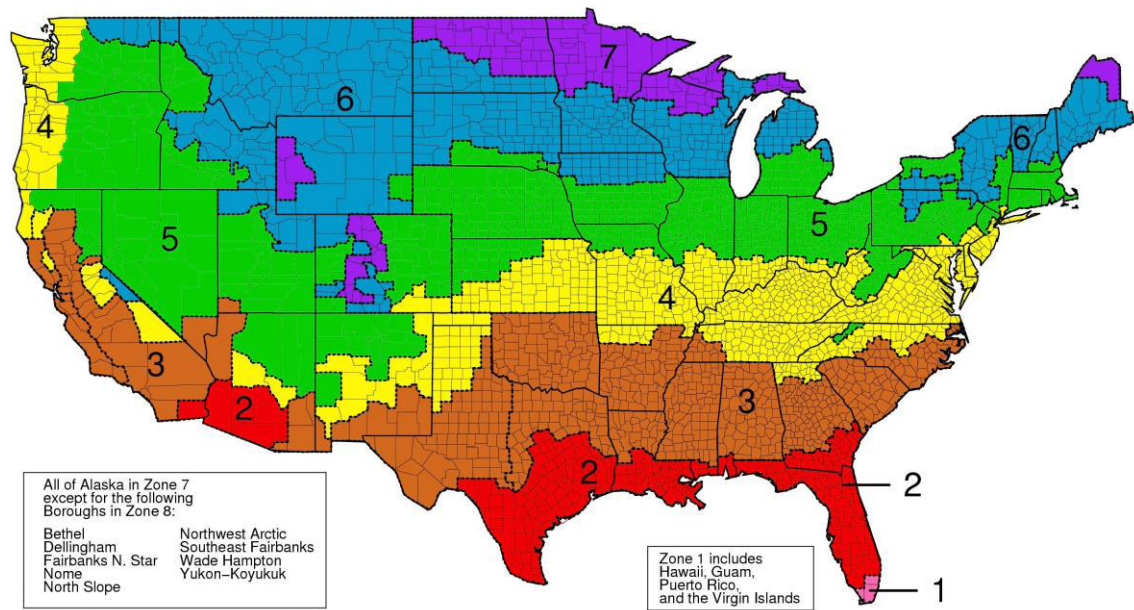

**Figure 1. Examples of Where to Insulate**

1. In unfinished attic spaces, insulate between and over the floor joists to seal off living spaces below.  
1A attic access door
2. In finished attic rooms with or without dormer, insulate...  
2A between the studs of "knee" walls;  
2B between the studs and rafters of exterior walls and roof;  
2C ceilings with cold spaces above;  
2D extend insulation into joist space to reduce air flows.
3. All exterior walls, including...  
3A walls between living spaces and unheated garages, shed roofs, or storage areas;  
3B foundation walls above ground level;  
3C foundation walls in heated basements, full wall either interior or exterior.
4. Floors above cold spaces, such as vented crawl spaces and unheated garages. Also insulate...  
4A any portion of the floor in a room that is cantilevered beyond the exterior wall below;  
4B slab floors built directly on the ground;  
4C as an alternative to floor insulation, foundation walls of unvented crawl spaces;  
4D extend insulation into joist space to reduce air flows.
5. Band joists.
6. Replacement or storm windows and caulk and seal around all windows and doors.

Figure 2 below shows the Department of Energy's climate zones, along with a short summary of our insulation recommendations for new houses. These recommendations are based on comparing your future energy savings to the current cost of installing insulation. A range is shown for many locations for these reasons:

- Energy costs vary greatly over each zone.
- Installed insulation costs vary greatly over each zone.
- Heating and cooling equipment efficiency varies from house to house.
- Our best estimate of future energy costs may not be exactly correct.



Zone	Heating system	Attic	Cathedral Ceiling	Wall		Floor
				Cavity	Insulation Sheathing	
1	All	R30 to R49	R22 to R38	R13 to R15	None	R13
2	Gas, oil, heat pump	R30 to R60	R22 to R38	R13 to R15	None	R13
	Electric furnace					R19-R25
3	Gas, oil, heat pump	R30 to R60	R22 to R38	R13 to R15	None	R25
	Electric furnace				R2.5 to R5	
4	Gas, oil, heat pump	R38 to R60	R30 to R38	R13 to R15	R2.5 to R6	R25-R30
	Electric furnace				R5 to R6	
5	Gas, oil, heat pump	R38 to R60	R30 to R38	R13 to R15	R2.5 to R6	R25-R30
	Electric furnace		R30 to R60	R13 to R21	R5 to R6	
6	All	R49 to R60	R30 to R60	R13 to R21	R5 to R6	R25-R30
7	All	R49 to R60	R30 to R60	R13 to R21	R5 to R6	R25-R30
8	All	R49 to R60	R30 to R60	R13 to R21	R5 to R6	R25-R30

Figure 2. Insulation Recommendations for New Wood-Framed Houses

So, how should you decide how much insulation to install?

The future energy savings, of course, depends upon how much energy costs in the future. Our best estimate is that fuel costs will rise at approximately the same rate as general inflation. If you think that fuel costs will increase more than that, you should install the greater amount of insulation shown. Looking at the map, if you think the energy costs in your area are greater than energy costs for other locations in same climate zone, you should install the greater amount of insulation.

We can also give you better guidance for your specific location and recommendations for other insulation locations in your home. The ZIP-Code calculator will actually let you enter your own insulation prices, energy costs, and heating and cooling system efficiencies. However, some personal computer security systems won't allow Java programs to run properly. The recommended R-values table can be helpful in those cases, because it will provide recommendations based on insulation and energy costs for your local area.

Both insulative sheathing and cavity insulation are specified for walls because it is important to use them together as a system. Any combination of sheathing and cavity insulation shown in Figure 2 will give you a similar life-cycle savings.

The band joists, or outside edges of the floor frames, should be insulated while the house is under construction. For most of the country, you should try to install R-30 in this location. If you live in Climate Zone 1, R-19 is adequate. More detailed drawings and insulation techniques for the band joist are shown in the Wall Insulation Technology Fact Sheet (see Appendix).

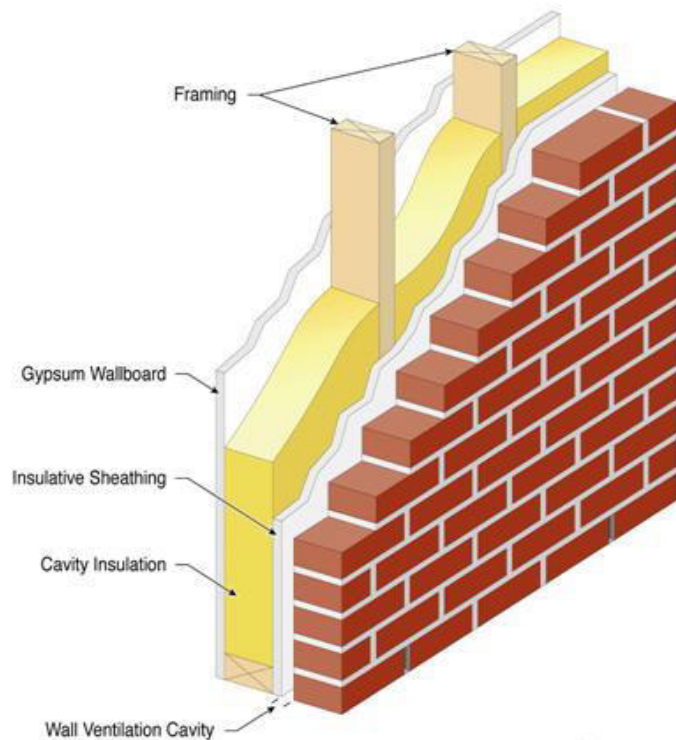

Foundation insulation options for new construction are broader than for existing homes. The builder may, for example, choose to insulate the exterior of a basement or crawlspace wall. You should discuss termite inspection and control options with your builder when choosing your foundation insulation method. Special sill plate (the joint between the top of the foundation and the bottom of the house frame) mineral fiber sealing products are designed to reduce air leaks if installed during the initial house construction. All flammable insulations or insulation facings must be covered or otherwise protected to meet fire codes. More information is given in the Basement Insulation Technology Fact Sheet (see Appendix).

If water lines and the ducts of your heating or air-conditioning system run through unheated or uncooled spaces, such as attic or crawlspaces, then the water lines and the ducts should be insulated. Make sure your contractor checks the ductwork for air leaks before installing the duct insulation. The contractor should then wrap the ducts with duct wrap insulation of R-6 with a

vapor retarder facing on the outer side. All joints where sections of insulation meet should have overlapped facings and be tightly sealed with fiber glass tape; but avoid compressing the insulation, thus reducing its thickness and R-value.

Return air ducts are more likely to be located inside the heated portion of the house where they don't need to be insulated, but they should still be sealed off from air passageways that connect to unheated areas. Drywall-to-ductwork connections should be inspected because they are often poor (or nonexistent) and lead to unwanted air flows through wall cavities.

## Air Sealing

Air sealing is important, not only because drafts are uncomfortable, but also because air leaks carry both moisture and energy, usually in the direction you don't want. For example, air leaks can carry hot humid outdoor air into your house in the summer, or can carry warm moist air from a bathroom into the attic in the winter.

Most homeowners are aware that air leaks into and out of their houses through small openings around doors and window frames and through fireplaces and chimneys. Air also enters the living space from other unheated parts of the house, such as attics, basements, or crawlspaces. The air travels through:

- any openings or cracks where two walls meet, where the wall meets the ceiling, or near interior door frames;
- gaps around electrical outlets, switch boxes, and recessed fixtures;
- gaps behind recessed cabinets, and furred or false ceilings such as kitchen or bathroom soffits;
- gaps around attic access hatches and pull-down stairs;
- behind bath tubs and shower stall units;
- through floor cavities of finished attics adjacent to unconditioned attic spaces;
- utility chaseways for ducts, etc., and
- plumbing and electrical wiring penetrations.

These leaks between the living space and other parts of the house are often much greater than the obvious leaks around windows and doors. Since many of these leakage paths are driven by the tendency for warm air to rise and cool air to fall, the attic is often the best place to stop them. ***It's important to stop these leaks before installing attic insulation because the insulation may hide them and make them less accessible.*** Usually, the attic insulation itself will not stop these leaks and you won't save as much as you expect because of the air flowing through or around the insulation.

There are several fact sheets that will help you stop these air leaks:

- Air sealing
- Air Sealing for New Home Construction
- Air Sealing Technology Fact Sheet (see Appendix)

When natural ventilation has been sharply reduced, as in a more energy-efficient house, it may be necessary to provide fresh air ventilation to avoid build-up of stale air and indoor air pollutants. Special air-to-air heat exchangers, or heat-recovery ventilators, are available for this purpose. It is also possible to incorporate a supply of fresh outside air into your heating and cooling system. This arrangement can be used to create a slightly higher pressure inside your home, which will prevent uncontrolled outside air infiltration into your home. For more details

on this arrangement, see "Integration with forced-air heating and air-conditioning systems" in the Whole-House Ventilation Systems Technology Fact Sheet (see Appendix).

## Moisture Control and Ventilation

We talk about moisture control in an insulation fact sheet because wet insulation doesn't work well. Also, insulation is an important part of your building envelope system, and all parts of that system must work together to keep moisture from causing damage to the structure or being health hazards to the occupants. For example, mold and mildew grow in moist areas, causing allergic reactions and damaging buildings.

Moisture can enter your home during the construction process. The building materials can get wet during construction due to rain, dew, or by lying on the damp ground. Concrete walls and foundations release water steadily as they continue to cure during the first year after a home is built. During the house's first winter, this construction moisture may be released into the building at a rate of more than two gallons per day, and during the second winter at a slower rate of about one gallon per day. You may need to use dehumidifiers during this initial time period.

### When Is Moisture a Problem?

Rain water can leak into your wall cavities if the windows are not properly flashed during installation. Also, when moist air touches a cold surface, some of the moisture may leave the air and condense, or become liquid. If moisture condenses inside a wall, or in your attic, you will not be able to see the water, but it can cause a number of problems.



### Four Things You Can Do to Avoid Moisture Problems:

- 1. Control liquid water. Rain coming through a wall, especially a basement or crawlspace wall, may be less apparent than a roof leak, especially if it is a relatively small leak and the water remains inside the wall cavity. Stop all rain-water paths into your home by:
  - Use a Weather-Resistive Barrier.
  - Caulk around all your windows and doors.
  - Direct all water coming off your roof away from your house by sloping the soil around your house so that water flows away from your house.
  - Use wide overhangs to keep the rain away from your walls and windows.
  - Use large gutters and gutter guards to help keep rain from dripping onto the ground near the house.

Be sure that the condensate from your air conditioner is properly drained away from your house. You should also be careful that watering systems for your lawn or flower beds do not spray water on the side of your house or saturate the ground near the house. It is also a good idea to check the caulking around your tub or shower to make sure that water is not leaking into your walls or floors.

- 2. Ventilate. You need to ventilate your home because you and your family generate moisture when you cook, shower, do laundry, and even when you breathe. More than 99% of the water used to water plants eventually enters the air. If you use an unvented

natural gas, propane, or kerosene space heater, all the products of combustion, including water vapor, are exhausted directly into your living space. This water vapor can add up to 5 to 15 gallons of water per day to the air inside your home. If your clothes dryer is not vented to the outside, or if the outdoor vent is closed off or clogged, all that moisture will enter your living space. Just by breathing and perspiring, a typical family adds about 3 gallons of water per day to their indoor air. You especially need to vent your kitchen and bathrooms. Be sure that these vents go directly outside, and not to your attic, where the moisture can cause problems. Remember that a vent does not work unless you turn it on; so select quieter models that you are more likely to use. If your attic is ventilated, it is important that you never cover or block attic vents with insulation. Take care to prevent loose-fill insulation from clogging attic vents by using baffles or rafter vents. These baffles also serve to keep the outside air from penetrating into the insulation. When you think about venting to remove moisture, you should also think about where the replacement air will come from, and how it will get into your house. For more information about controlled ventilation, see the Whole-House Ventilation Systems Technology Fact Sheet (see Appendix).

- 3. Stop Air Leaks. It is very important to seal up all air-leakage paths between your living spaces and other parts of your building structure. Measurements have shown that air leaking into walls and attics carries significant amounts of moisture. Remember that if any air is leaking through electrical outlets or around plumbing connections into your wall cavities, moisture is carried along the same path. The same holds true for air moving through any leaks between your home and the attic, crawlspace, or garage. Even very small leaks in duct work can carry large amounts of moisture, because the airflow in your ducts is much greater than other airflows in your home. This is especially a problem if your ducts travel through a crawlspace or attic, so be sure to seal these ducts properly (and keep them sealed!). Return ducts are even more likely to be leaky, because they often involve joints between drywall and ductwork that may be poorly sealed, or even not sealed at all.
- 4. Plan a moisture escape path. Typical attic ventilation arrangements are one example of a planned escape path for moisture that has traveled from your home's interior into the attic space. Cold air almost always contains less water than hot air, so diffusion usually carries moisture from a warm place to a cold place. You can let moisture escape from a wall cavity to the dry outdoors during the winter, or to the dry indoors during the summer, by avoiding the use of vinyl wall coverings or low-perm paint. You can also use a dehumidifier to reduce moisture levels in your home, but it will increase your energy use and you must be sure to keep it clean to avoid mold growth. If you use a humidifier for comfort during the winter months, be sure that there are no closed-off rooms where the humidity level is too high.

Should you use vapor retarders?

Moisture can travel from the ground through the foundation and up into your walls, and through slab floors into your home. So your builder should always include a vapor retarder between the

foundation and the walls. Should you include a vapor retarder in your wall? If so, where? If the outside air is colder and drier than the inside of a home, then moisture from inside the warm house will try to diffuse through the walls and ceiling toward the cold, dry outside air. If the outside air is hot and humid, then moisture from outside will try to diffuse through the walls toward the dry, air-conditioned inside air. We used to tell people to install vapor retarders to try and stop this moisture diffusion. But we have learned that if moisture moves both ways for significant parts of the year, you're better off not using a vapor retarder in the walls at all.

### **Installation Issues**

Your builder will most likely hire a subcontractor to install the insulation in your new home. However, it is a good idea to educate yourself about proper installation methods because an improper installation can reduce your energy savings.

## **INSULATION INSTALLATION PRECAUTIONS**

- Wear clothing adequate to protect against skin contact and irritation. A long-sleeved shirt with collar and cuffs buttoned, gloves, hat, glasses, and disposable dust respirator are advisable in all do-it-yourself insulation projects. Also, read the label and follow all the manufacturer's directions.
- Do not cover or hand-pack insulation around bare stove pipes, electrical fixtures, motors, or any heat-producing equipment such as recessed lighting fixtures. If you pack insulation around these heat-producing locations, the heat can build up, leading to fire. Electrical fire-safety codes prohibit the installation of thermal insulation within three inches of a recessed fixture enclosure, wiring compartment, or ballast, or above the fixture so that it will trap heat and prevent free circulation of air, unless the fixture is identified by label as suitable for insulation to be in direct contact with the fixture. **THIS IS FOR FIRE SAFETY.**
- Do not cover attic vents with insulation. Proper ventilation must be maintained to avoid overheating in summer and moisture build-up all year long.

## Attics

For blown-in loose fill insulation, each bag of insulating material used by the contractor should be marked with an R-value for the area to be covered. Although these figures may differ among manufacturers, the area figure will tell you the right number of bags to be used. Similarly, packages of other types of insulation should be identified by their R-value. It is important that you check that the proper amount is installed in your residence. Ask the contractor to attach vertical rulers to the joists prior to a loose-fill installation in your attic to help you see that the proper depth was installed. Also, the installer must provide a signed and dated statement describing the insulation installed, stating thickness, coverage area, R- value, and number of bags installed. In some areas, infrared thermography services are offered to help discover any gaps in the insulation.

In some houses, it is easier to get complete coverage of the attic floor with blown-in loose-fill insulation. Loose-fill insulation must be prevented from shifting into vents or from contacting heat-producing equipment (such as recessed lighting fixtures) by using baffles or retainers.

If batts or rolls are used, the first layer should be fit between the joists. The second layer should be placed perpendicular to the first because that will help to cover the tops of the joists themselves and reduce thermal bridging through the frame. Also, be sure to insulate the trap or access door. Although the area of the door is small, an uninsulated attic door will reduce energy savings substantially.

To be effective, Reflective Systems must be installed according to the manufacturer's instructions.

Radiant barriers may be installed in attics in several configurations. The radiant barrier is most often attached near the roof, to the bottom surface of the attic truss chords or to the rafter framing. A radiant barrier should never be placed on top of your insulation or on the attic floor because it will soon be covered with dust and will not work. A separate DOE fact sheet is available for radiant barriers to show which parts of the country are most likely to benefit from this type of system.



## Walls



ORNL 07-G01655/abh

When batt insulation is installed, it is fit between the wood frame studs, according to the manufacturer's instructions. The batts must be carefully cut to fit around obstructions, such as window frames, pipes, wires, and electrical boxes with no gaps.

- Don't compress the insulation to fit behind pipes or wires. Instead cut to the middle of the batt's thickness so you have one flap under the pipe or wire and the other flap over the pipe or wire.
- One common mistake is to leave narrow places between close-spaced wall studs uninsulated. Even though these spaces may look like a very small part of the wall, small uninsulated areas can greatly reduce the insulation performance of the whole wall. Strips of insulation should be cut off and stuffed into such tight spaces by hand.
- The kraft paper or foil vapor retarder facings on many blanket insulation products must be covered with gypsum or interior paneling because of fire considerations.

Blown-in cellulose or spray foam can be used to fill wall cavities. Both of these products can do a good job of filling in the space around wires and other obstructions and in filling any oddly-shaped areas. For cellulose, some form of netting is used to hold the cellulose in place until the drywall is installed. For spray-foam, it is important that the application be finished off neatly to avoid problems with the drywall installation.

Masonry walls should be insulated on the exterior surface.

### Design Options

#### Design Option: Crawlspace and Slabs

Many building codes presently require installation of crawlspace vents to provide ventilation with outside air, but there is no compelling technical basis for crawlspace ventilation requirements. If the crawlspace is vented, the floor should be insulated and any pipes or ducts in the crawlspace should be insulated as well. In some climates, pipes in vented crawlspaces must also be wrapped with heat trace wires to avoid frozen pipes. If the crawlspace is not vented, it is crucial that all of the crawlspace ground area be covered with a durable vapor retarder, such as heavy-weight polyethylene film. (This is also a good practice for vented crawlspaces.) For unvented crawlspaces, the insulation should be placed on the inside wall of the crawlspace instead of under the floor above. The insulation should also extend a few feet over the ground surface inside the crawlspace, lying on top of the durable vapor retarder. For the unvented arrangement, the air within the crawlspace is actually incorporated as a part of the conditioned

space within the house, as if it were a basement. The Crawlspace Insulation Technology Fact Sheet gives more details about this design option (see Appendix). If you choose a slab foundation, be sure to follow the recommendations for insulation installation and moisture control found in the Slab Insulation Technology Fact Sheet (see Appendix).

### **Design Option: Advanced Wall Framing**

Advanced wall framing techniques can be used that will reduce the energy losses through the walls with little or no additional costs. Details are given in the Wall Insulation Technology Fact Sheet.

### **Design Option: Metal Framing**

Some new homes are built using metal frames instead of wood. Such frames are not susceptible to insect problems that can damage wood-framed structures. However, when you insulate a metal-framed building, it is important to recognize that much more heat flows through metal studs and joists than through pieces of wood. Because of this difference, placing insulation just between the wall studs, or just between attic or floor joists, doesn't work as well for metal-framed houses as it does for wood-framed houses. If your walls have metal frames, you will need to place continuous insulative sheathing over the outside of the wall frame, between the metal framing pieces and your exterior siding in addition to insulating the space between the studs. (Note that this insulative sheathing cannot take the place of plywood or other seismic bracing.) If your attic has metal joists, you may want to place rigid foam insulation between the joists and the ceiling drywall and to cover the attic joists with insulation to the extent possible.

### **Design Option: Insulating Concrete Forms**

Insulating concrete forms can be used to construct walls for new homes. These special concrete walls come in a variety of configurations and can provide additional thermal mass to your home to help reduce the effect of outdoor temperature swings.

### **Design Option: Massive Walls**

The most common house type in this country is the light-construction frame house. Massive walls are less common, and include buildings made from concrete, concrete block, and log. These buildings will use less energy than wood-frame construction in many parts of the country because they can store heat from the daytime sun to provide needed heat at night, or can cool down at night to reduce air-conditioning loads during the day. Research shows that such massive wall systems perform best if the insulation is located on the outside of the wall. See the ZipCode Calculator or the ZipCode table to find out how much insulation you should use.

### **Design Option: Structural Insulated Panels**

Structural insulated panels can be used to construct a house. These panels sandwich plastic foam insulation between two layers of a wood or composite product, thus eliminating the need for structural wood framing members. These systems save energy in two ways, first by reducing the heat losses that would have gone through the wood frame, and second by reducing air leaks. Both of these changes represent significant energy savings. Just stopping the energy flowing through the wall framing could save 25% of the wall's energy losses.

### **Design Option: External Insulation Finish System**

Some homes are built with an External Insulation Finish System that gives a stucco-like appearance. In the past, there were quality control problems where poor construction led to water leaks into the wall system, usually around window frames. Newer versions of the external insulation finish system have been designed to be more robust and to allow any water entering through a construction defect to drain harmlessly out of the wall. This system can be used to finish wood-framed, metal-framed, and masonry walls. It offers special advantages for the metal-framed and masonry walls because the continuous external insulation layer optimizes the thermal performance of both of those two wall systems.

### **Design Option: Attic Ventilation or a Cathedralized Attic**

It is important that the house design, and construction, minimize the transfer of moisture from the living space to the attic. To handle any moisture that does migrate into the attic, traditional attic design calls for ventilation. Attics may be ventilated with a combination of soffit vents at eaves and continuous ridge vents. Attic vents may also be installed in gable faces. Many codes and standards require one square foot of unobstructed ventilation opening for each 300 square feet of attic floor area if a vapor retarder is included in the ceiling separating the attic from the living space. Twice as much ventilation is recommended if there is no vapor retarder. The net free area of a vent is smaller than its overall dimension because part of the vent opening is blocked by meshes or louvers. The openings should be equally distributed between the soffit and ridge vents or between each gable face. Never cover or block vents with insulation. Use baffles to prevent loose-fill insulation from clogging vents.

During the house design phase, you can choose a cathedralized attic, which is not ventilated, unless attic ventilation is required by code in your area.



In a cathedralized attic, the insulation is placed on the underside of the roof instead of on the attic floor. (Think of a room with a cathedral ceiling, only this room is the attic and the ceiling is unfinished.) For this arrangement, the attic space is incorporated as a part of the conditioned space within the house. One advantage of this approach is that the attic will retain any energy lost by ductwork in the attic. Up to 25% of your heating and cooling energy can be wasted by leaky ductwork in a traditional attic.

A disadvantage of an unventilated attic is that the underside of the roof has a greater area than the attic floor. This greater area, and the downward-facing geometry, cause this option to be more costly than insulating the attic floor, so that usually the installed insulation R-value is less. The lower R-value and the greater area mean that more heat is lost through the cathedralized attic roof than would have been lost through the traditional attic floor. Also, a ventilated attic can reduce summer air-conditioning loads relative to the cathedralized attic. The home owner must balance these two effects, reduced duct energy losses versus increased heating and cooling loads. Of course another option is to ventilate the attic, but locate the ductwork elsewhere within the conditioned part of the house, such as between floors in a multi-story building.

## Adding Insulation to an Existing House (Smart Approaches)

Does your home need more insulation? Unless your home was constructed with special attention to energy efficiency, adding insulation will probably reduce your utility bills. Much of the existing housing stock in the United States was not insulated to the levels used today. Older homes are likely to use more energy than newer homes, leading to higher heating and air-conditioning bills.

### Where and How Much

Adding more insulation where you already have some, such as in an attic, will save energy. You can save even greater amounts of energy if you install insulation into places in your home that have never been insulated. Figure 1 on Page 8 shows which building spaces should be insulated. These might include an uninsulated floor over a garage or crawlspace, or a wall that separates a room from the attic. Figure 3 on Page 20 can give you general guidance regarding the appropriate amount of insulation you should add to your home, and the rest of this page will provide more specific information.

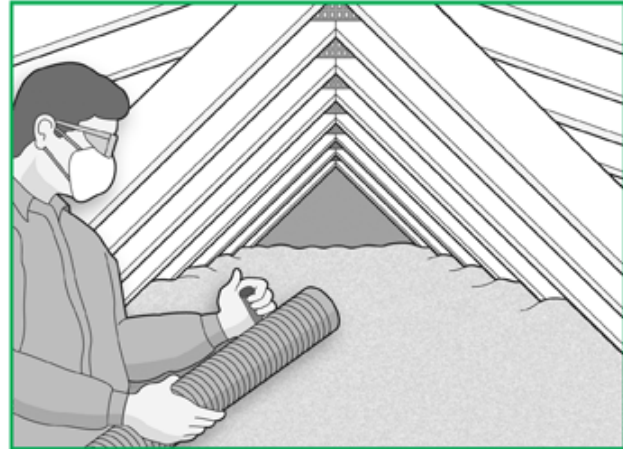
OPRM, 07-001657/ab1

A qualified home energy auditor will include an insulation check as a routine part of an energy audit. For information about home energy audits, call your local utility company. State energy offices are another valuable resource for information. An energy audit of your house will identify the amount of insulation you have and need, and will likely recommend other improvements as well. If you don't have someone inspect your home, you'll need to find out how much insulation you already have.

After you find out how much you have, you can use the ZipCode tool to find out how much you should add. This recommendation balances future utility bill savings against the current cost of installing insulation. So the amount of insulation you need depends on your climate and heating fuel (gas, oil, electricity), and whether or not you have an air conditioner. The program is called the ZipCode because it includes weather and cost information for local regions defined by the first three digits of each postal service zip code. The program also allows you to define your own local costs and to input certain facts about your house to improve the accuracy of the recommendations. However, some personal computer security systems won't allow Java programs to run properly. The recommended R-values table can be helpful in those cases, because it will provide recommendations based on insulation and energy costs for your local area.

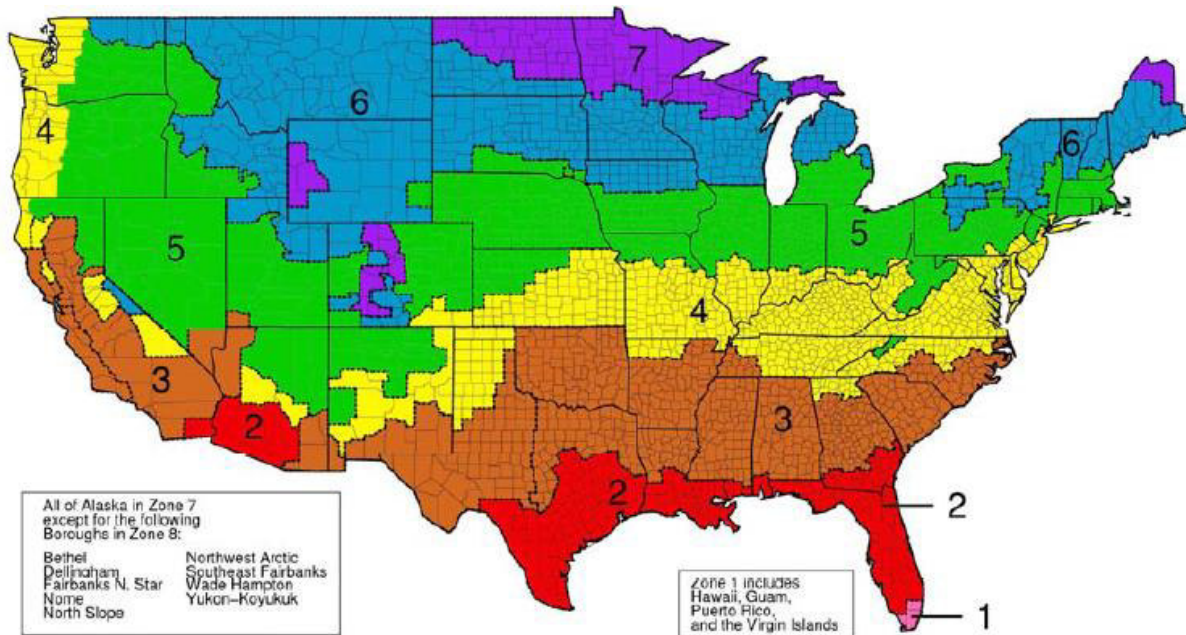

Zone	Add Insulation to Attic		Floor
	Uninsulated Attic	Existing 3-4 Inches of Insulation	
1	R30 to R49	R25 to R30	R13
2	R30 to R60	R25 to R38	R13 to R19
3	R30 to R60	R25 to R38	R19 to R25
4	R38 to R60	R38	R25 to R30
5 to 8	R49 to R60	R38 to R49	R25 to R30

**Wall Insulation:** *Whenever exterior siding is removed on an*

**Uninsulated wood-frame wall:**

- Drill holes in the sheathing and blow insulation into the empty wall cavity before installing the new siding, and
- Zones 3-4: Add R5 insulative wall sheathing beneath the new siding
- Zones 5-8: Add R5 to R6 insulative wall sheathing beneath the new siding.

**Insulated wood-frame wall:**

- For Zones 4 to 8: Add R5 insulative sheathing before installing the new siding

**Figure 3. Insulation Recommendations for Existing Wood-Framed Houses**

## How Much Insulation Do I Already Have?

Look into your attic. We start with the attic because it is usually easy to add insulation to an attic. This table will help you figure out what kind of insulation you have and what its R-value is.

What you see:		What it probably is	Depth (inches)	Total R-value
Loose fibers	light-weight yellow, pink, or white	fiberglass	_____	=2.5×depth
	dense gray or near-white, may have black specks	rock wool	_____	=2.8×depth
	small gray flat pieces or fibers (from newsprint)	cellulose	_____	=3.7×depth
Granules	light-weight	vermiculite or perlite	_____	=2.7×depth
Batts	light-weight yellow, pink, or white	fiberglass	_____	=3.2×depth

Look into your walls. It is difficult to add insulation to existing walls unless:

- You are planning to add new siding to your house, or
- You plan to finish unfinished space (like a basement or bonus room).

If so, you need to know whether the exterior walls are already insulated or not. One method is to use an electrical outlet on the wall, but first be sure to turn off the power to the outlet. Then remove the cover plate and shine a flashlight into the crack around the outlet box. You should be able to see whether or not insulation is in the wall. Also, you should check separate outlets on the first and second floor, and in old and new parts of the house, because wall insulation in one wall doesn't necessarily mean that it's everywhere in the house. An alternative to checking through electrical outlets is to remove and then replace a small section of the exterior siding.

Look under your floors. Look at the underside of any floor over an unheated space like a garage, basement, or crawlspace. Inspect and measure the thickness of any insulation you find there. It will most likely be a fiberglass batt, so multiply the thickness in inches by 3.2 to find out the R-value (or the R-value might be visible on a product label). If the insulation is a foam board or sprayed-on foam, use any visible label information or multiply the thickness in inches by 5 to estimate the R-value.

Look at your ductwork. Don't overlook another area in your home where energy can be saved - the ductwork of the heating and air-conditioning system. If the ducts of your heating or air-conditioning system run through unheated or uncooled spaces in your home, such as attic or crawlspaces, then the ducts should be insulated. First check the ductwork for air leaks. Repair leaking joints first with mechanical fasteners, then seal any remaining leaks with water-soluble mastic and embedded fiber glass mesh. Never use gray cloth duct tape because it degrades, cracks, and loses its bond with age. If a joint has to be accessible for future maintenance, use pressure- or heat-sensitive aluminum foil tape. Then wrap the ducts with duct wrap insulation of R-6 with a vapor retarder facing on the outer side. All joints where sections of insulation meet should have overlapped facings and be tightly sealed with fiber glass tape; but avoid compressing the insulation, thus reducing its thickness and R-value.

Return air ducts are often located inside the heated portion of the house where they don't need to be insulated, but they should still be sealed off from air passageways that connect to unheated areas. Drywall-to-ductwork connections should be inspected because they are often poor (or

nonexistent) and lead to unwanted air flows through wall cavities. If the return air ducts are located in an unconditioned part of the building, they should be insulated.

Look at your pipes. If water pipes run through unheated or uncooled spaces in your home, such as attic or crawlspaces, then the pipes should be insulated.

### Air Sealing

Air sealing is important, not only because drafts are uncomfortable, but also because air leaks carry both moisture and energy, usually in the direction you don't want. For example, air leaks can carry hot humid outdoor air into your house in the summer, or can carry warm moist air from a bathroom into the attic in the winter.

Most homeowners are aware that air leaks into and out of their houses through small openings around doors and window frames and through fireplaces and chimneys. Air also enters the living space from other unheated parts of the house, such as attics, basements, or crawlspaces. The air travels through:

- any openings or cracks where two walls meet, where the wall meets the ceiling, or near interior door frames;
- gaps around electrical outlets, switch boxes, and recessed fixtures;
- gaps behind recessed cabinets, and furred or false ceilings such as kitchen or bathroom soffits;
- gaps around attic access hatches and pull-down stairs;
- behind bath tubs and shower stall units;
- through floor cavities of finished attics adjacent to unconditioned attic spaces;
- utility chaseways for ducts, etc., and
- plumbing and electrical wiring penetrations.

These leaks between the living space and other parts of the house are often much greater than the obvious leaks around windows and doors. Since many of these leakage paths are driven by the tendency for warm air to rise and cool air to fall, the attic is often the best place to stop them. ***It's important to stop these leaks before adding attic insulation because the insulation may hide them and make them less accessible.*** Usually, the attic insulation itself will not stop these leaks and you won't save as much as you expect because of the air flowing through or around the insulation.

There are many fact sheets that will help you stop these air leaks:

- Air sealing
- Air sealing an existing home
- Air Sealing Technology Fact Sheet (see Appendix)
- Air Sealing in Occupied Homes (1995)

## Moisture Control and Ventilation

We talk about moisture control in an insulation fact sheet because wet insulation doesn't work well. Also, insulation is an important part of your building envelope system, and all parts of that system must work together to keep moisture from causing damage to the structure or being health hazards to the occupants. For example, mold and mildew grow in moist areas, causing allergic reactions and damaging buildings.

### When Is Moisture a Problem?

When moist air touches a cold surface, some of the moisture may leave the air and condense, or become liquid. If moisture condenses inside a wall, or in your attic, you will not be able to see the water, but it can cause a number of problems. Adding insulation can either cause or cure a moisture problem. When you insulate a wall, you change the temperature inside the wall. That can mean that a surface inside the

wall, such as the sheathing behind your siding, will be much colder in the winter than it was before you insulated. This cold surface could become a place where water vapor traveling through the wall condenses and leads to trouble. The same thing can happen within your attic or under your house. On the other hand, the new temperature profile could prevent condensation and help keep your walls or attic drier than they would have been.



### Four Things You Can Do to Avoid Moisture Problems:

1. Control liquid water. Rain coming through a wall, especially a basement or crawlspace wall, may be less apparent than a roof leak, especially if it is a relatively small leak and the water remains inside the wall cavity. Stop all rain-water paths into your home by:

- making sure your roof is in good condition,
- caulking around all your windows and doors, and
- keeping your gutters clean - and be sure the gutter drainage flows away from your house.
- If you replace your gutters, choose larger gutters and gutter guards to help keep rain from dripping onto the ground near the house.

Be sure that the condensate from your air conditioner is properly drained away from your house. You should also be careful that watering systems for your lawn or flower beds do not spray water on the side of your house or saturate the ground near the house. It is also a good idea to check the caulking around your tub or shower to make sure that water is not leaking into your walls or floors. You can place thick plastic sheets on the floor of your crawlspace to keep any moisture in the ground from getting into the crawlspace air, and then into your house.

2. Ventilate. You need to ventilate your home because you and your family generate moisture when you cook, shower, do laundry, and even when you breathe. More than 99% of the water used to water plants eventually enters the air. If you use an unvented natural gas, propane, or kerosene space heater, all the products of combustion, including water vapor, are exhausted directly into your living space. This water vapor can add 5 to 15 gallons of water per day to the



air inside your home. If your clothes dryer is not vented to the outside, or if the outdoor vent is closed off or clogged, all that moisture will enter your living space. Just by breathing and perspiring, a typical family adds about 3 gallons of water per day to their indoor air. You especially need to vent your kitchen and bathrooms. Be sure that these vents go directly outside, and not to your attic, where the moisture can cause problems. Remember that a vent does not work unless you turn it on; so if you have a vent you are not using because it is too noisy, replace it with a quieter model. If your attic is ventilated, it is important that you never cover or block attic vents with insulation. Take care to prevent loose-fill insulation from clogging attic vents by using baffles or rafter vents. When you think about venting to remove moisture, you should also think about where the replacement air will come from, and how it will get into your house. When natural ventilation has been sharply reduced with extra air-sealing efforts, it may be necessary to provide fresh air ventilation to avoid build-up of stale air and indoor air pollutants. Special air-to-air heat exchangers, or heat-recovery ventilators, are available for this purpose. For more information about controlled ventilation, see the Whole-House Ventilation Systems Technology Fact Sheet.

3. Stop Air Leaks. It is very important to seal up all air-leakage paths between your living spaces and other parts of your building structure. Measurements have shown that air leaking into walls and attics carries significant amounts of moisture. Remember that if any air is leaking through electrical outlets or around plumbing connections into your wall cavities, moisture is carried along the same path. The same holds true for air moving through any leaks between your home and the attic, crawlspace, or garage. Even very small leaks in duct work can carry large amounts of moisture, because the airflow in your ducts is much greater than other airflows in your home. This is especially a problem if your ducts travel through a crawlspace or attic, so be sure to seal these ducts properly (and keep them sealed!). Return ducts are even more likely to be leaky, because they often involve joints between drywall and ductwork that may be poorly sealed, or even not sealed at all.

4. Plan a moisture escape path. Typical attic ventilation arrangements are one example of a planned escape path for moisture that has traveled from your home's interior into the attic space. Cold air almost always contains less water than hot air, so diffusion usually carries moisture from a warm place to a cold place. You can let moisture escape from a wall cavity to the dry outdoors during the winter, or to the dry indoors during the summer, by avoiding the use of vinyl wall coverings or low-perm paint. You can also use a dehumidifier to reduce moisture levels in your home, but it will increase your energy use and you must be sure to keep it clean to avoid mold growth. If you use a humidifier for comfort during the winter months, be sure that there are no closed-off rooms where the humidity level is too high.

## Insulation Installation, the Retrofit Challenges

### INSULATION INSTALLATION PRECAUTIONS

- Wear clothing adequate to protect against skin contact and irritation. A long-sleeved shirt with collar and cuffs buttoned, gloves, hat, glasses, and disposable dust respirator are advisable in all do-it-yourself insulation projects. Also, read the label and follow all the manufacturer's directions.
- Do not cover or hand-pack insulation around bare stove pipes, electrical fixtures, motors, or any heat-producing equipment such as recessed lighting fixtures. If you pack insulation around these heat-producing locations, the heat can build up, leading to fire. Electrical fire-safety codes prohibit the installation of thermal insulation within three inches of a recessed fixture enclosure, wiring compartment, or ballast, or above the fixture so that it will trap heat and prevent free circulation of air, unless the fixture is identified by label as suitable for insulation to be in direct contact with the fixture. **THIS IS FOR FIRE SAFETY.**
- Do not cover attic vents with insulation. Proper ventilation must be maintained to avoid overheating in summer and moisture build-up all year long.

Whether you install the insulation yourself or have it done by a contractor, it is a good idea to educate yourself about proper installation methods because an improper installation can reduce your energy savings.

Also, if your house is very old, you may want to have an electrician check to see if:

- the electrical insulation on your wiring is degraded,
- the wires are overloaded, or
- knob and tube wiring was used (often found in homes built before 1940).

If any of these wiring situations exists in your house, it may be hazardous to add thermal insulation within a closed cavity around the wires because that could cause the wires to overheat. **THIS IS FOR FIRE SAFETY.** The National Electric Code forbids the installation of loose, rolled, or foam-in-place insulation around knob and tube wiring.

Adding thermal insulation to the ceiling or walls of a mobile home is complex and usually requires installation by specialists.

If adding insulation over existing insulation, do NOT use a vapor barrier between the two layers!

#### IF YOU HAVE IT DONE PROFESSIONALLY

You should obtain cost estimates from several contractors for a stated R-value. Make sure you describe the job in writing in the same terms to each one. You may want to ask each contractor about their air-sealing services as well. Remember that you want good quality materials and labor, as well as a low price. **Do not be surprised to find the quoted prices for a given R-value installation to vary by a factor of two or more.** When you talk to a contractor, talk of R-values. Don't forget that R-values are determined by material type, thickness, and installed weight per square foot, not by thickness alone.

### Attics

On unfinished attic floors, work from the perimeter toward the attic door. Be careful about where you step in the attic. Walk only on the joists so that you won't fall through the drywall ceiling. You may need to place walking boards across the tops of the joists to make the job easier.

Remember that it is important to seal up air leaks between your living space and the attic before adding insulation in your attic.

Installing batts and rolls in attics is fairly easy, but doing it right is very important. Use unfaced batts, especially if reinsulating over existing insulation. If there is not any insulation in your attic, fit the insulation between the joists. If the existing insulation is near or above the top of the joists, it is a good idea to place the new batts perpendicular to the old ones because that will help to cover the tops of the joists themselves and reduce thermal bridging through the frame. Also, be sure to insulate the trap or access door. Although the area of the door is small, an uninsulated attic door will reduce energy savings substantially.

For blown-in loose fill insulation, each bag of insulating material used by the contractor should be marked with an R-value for the area to be covered. Although these figures may differ among manufacturers, the area figure will tell you the right number of bags to be used. Similarly, packages of other types of insulation should be identified by their R-value. It is important that you check that the proper amount is installed in your residence. Ask the contractor to attach vertical rulers to the joists prior to a loose-fill installation in your attic to help you see that the proper depth was installed. Also, the installer must provide a signed and dated statement describing the insulation installed, stating thickness, coverage area, R-value, and number of bags installed. In some areas, infrared thermography services are offered to help discover any gaps in the insulation.

In some houses, it is easier to get complete coverage of the attic floor with blown-in loose-fill insulation. It is best to hire an insulation contractor for this job. Loose-fill insulation must be prevented from shifting into vents or from contacting heat-producing equipment (such as recessed lighting fixtures). Block off those areas with baffles or retainers to hold the loose-fill insulation in place.

When you stack new insulation on top of existing attic insulation, the existing insulation is compressed a small amount. This will slightly decrease the R-value of the existing insulation. This effect is most important if the new insulation is more dense than the old insulation. You can compensate for this stacking effect and achieve the desired total R-value by adding about one extra inch of insulation if the old insulation is fiber glass, or about 1/2 inch if the old insulation is rock wool or cellulose.

Reflective Systems are installed in a manner similar to placing batts and blankets. Proper installation is very important if the insulation is to be effective. Study and follow the manufacturer's instructions. Often, reflective insulation materials have flanges that are to be stapled to joists. Since reflective foil will conduct electricity, avoid making contact with any bare electrical wiring.

Radiant barriers may be installed in attics in several configurations. The radiant barrier is most often attached near the roof, to the bottom surface of the attic truss chords or to the rafter framing. Do not lay a radiant barrier on top of your insulation or on the attic floor because it will soon be covered with dust and will not work. A separate DOE fact sheet is available for radiant barriers to show which parts of the country are most likely to benefit from this type of system.

If your attic has NO insulation, you may decide to insulate the underside of the roof instead of the attic floor. (This option is more often used in new houses and is described in Design Option: ATTIC VENTILATION OR A CATHEDRALIZED ATTIC). If you choose the cathedralized attic approach, all attic vents must be sealed. Spray-foam is then often used to insulate the underside of the roof sheathing. If batts are used for this purpose, they must be secured in a manner similar to that described below for insulating under floors. It is best to hire an insulation contractor with experience in this type of installation for this job.

## Walls

Installing insulation in the cavity of exterior walls is difficult. However, when new siding is to be installed, it is a good idea to consider adding thermal insulation under the new siding. The Retrofit Best Practices Guide provides useful information about adding insulation when you remodel the outside of your house. It usually requires the services of a contractor who has special equipment for blowing loose-fill insulation into the cavity through small holes cut through the sidewall, which later are closed.

It is sometimes feasible to install rigid insulation on the outdoor side of masonry sidewalls such as concrete block or poured concrete. However, if that is not an option, you can use rigid insulation boards or batts to insulate the interior of masonry walls. To install boards, wood furring strips should be fastened to the wall first. These strips provide a nailing base for attaching interior finishes over the insulation. Fire safety codes require that a gypsum board finish, at least ½ inch thick, be placed over plastic foam insulation. The gypsum board must be attached to the wood furring strips or underlying masonry using nails or screws.

The first-floor band joist may be accessible from the basement or crawlspace. Make sure it is properly insulated as shown in Figure 1. More detailed drawings and insulation techniques for the band joist are shown in the Wall Insulation Technology Fact Sheet (see Appendix).



## Basement Walls

When using batt or rigid insulation to insulate the inside of concrete basement walls, it is necessary to attach wood furring strips to the walls by nailing or bonding, or to build an interior stud-wall assembly on which the interior finish can be attached after the insulation is installed. The cavity created by the added framing should be thick enough for the desired insulation R-value.

The kraft paper or standard foil vapor retarder facings on many blanket insulation products must be covered with gypsum or interior paneling because of fire considerations. Some blanket products are available without these facings or with a special flame resistant facing (labeled FS25 - or flame spread index 25) for places where the facing would not be covered. Sometimes the flame-resistant cover can be purchased separately from the insulation. Also, there are special fiber glass blanket products available for basement walls that require less framing and can be left exposed. These blankets have a flame-resistant facing and are labeled to show that they comply with ASTM C 665, Type II, Class A.

More information is given in the Basement Insulation Technology Fact Sheet (see Appendix).

## Floors and Crawlspace

If you have a floor over a crawlspace, you can EITHER:

- Insulate the underside of the floor and ventilate the crawlspace, OR
- Leave the floor uninsulated and insulate the walls of an unventilated crawlspace.

When batts or rolls are used on the underside of a floor above an unheated crawlspace or basement, fit the insulation between the beams or joists and push it up against the floor overhead as securely as possible without excessive compaction of the insulation. The insulation can be held in place, either by tacking chicken wire (poultry netting) to the edges of the joist, or with snap-in wire holders. Batts and rolls must be cut and fit around cross-bracing between floor joists or any other obstructions. Strips of insulation may be cut off and stuffed into tight spaces by hand. Don't forget to place insulation against the perimeter that rests on the sill plate. If you insulate above an unheated crawlspace or basement, you will also need to insulate any ducts or pipes running through this space. Otherwise, pipes could freeze and burst during cold weather.

Reflective Systems are installed in a manner similar to placing batts. Proper installation is very important if the insulation is to be effective. Study and follow the manufacturer's instructions. Often, reflective insulation materials have flanges that are to be stapled to floor joists. Since reflective foil will conduct electricity, one must avoid making contact with any bare electrical wiring.

Spray-foam can be used to insulate the underside of a floor. The spray foam can do a good job of filling in the space around wires and other obstructions and in filling any oddly-shaped areas. It is best to hire an insulation contractor with experience in this type of installation.

When a fiberglass blanket is used to insulate the walls of an unventilated crawlspace, it is sometimes necessary to attach wood furring strips to the walls by nailing or bonding. The insulation can then be stapled or tacked into place. Alternatively, the insulation can be fastened to the sill plate and draped down the wall. You should continue the insulation over the floor of the crawl space for about two feet on top of the required ground vapor retarder. Because the insulation will be exposed, be sure to use either an unfaced product or one with the appropriate flame spread rating. When rigid foam insulation boards are used to insulate the walls of an unventilated crawlspace, they can be bonded to the wall using recommended adhesives. Because the insulation will be exposed, be sure to check the local fire codes and the flame-spread rating of the insulation product. If you live in an area prone to termite damage, check with a pest control professional to see if you need to provide for termite inspections.

## Resources and Links

Additional and more detailed information about thermal insulation materials and installation and about energy conservation in buildings is available from the agencies and organizations listed below. Your public utility company may also provide information and assistance on home energy conservation practices and materials.

### Internet Sites



**Energy Star** Programs supported by the Environmental Protection Agency and the Department of Energy. These programs include information about Energy Star new homes and home improvement,

<http://www.energystar.gov>

Building Technology Program Publications, see "Technology Fact Sheets"

### Computer Programs

ZIP-Code Computer Program:

Operable version found on the internet at:

<http://www.ornl.gov/~roofs/Zip/ZipHome.html>

Home Energy Saver, a do-it-yourself energy audit tool produced by Lawrence Berkeley National Laboratory's Center for Building Science,

<http://homeenergysaver.lbl.gov>

### Reference Sources

**U.S. Department of Energy**

**Energy Efficiency and Renewable Energy Program Office Home Page**

<http://www.eere.energy.gov>

**Insulation Contractors Association of America (ICAA)**

Phone: 703-739-0356

<http://www.insulate.org/>

**National Association of Home Builders (NAHB)**

1201 15<sup>th</sup> Street NW

Washington, DC 20005

Phone: 202-266-8200 x0, 800-368-5242, Fax: 202-266-8400

<http://www.nahb.org/>

**NAHB Research Center, Inc.**

400 Prince Georges Boulevard

Upper Marlboro, MD 20774

Phone: 800-638-8556

<http://www.nahbrc.com>

# Guidelines for New Home Construction

## Building Standards and Guidelines Program (BSGP)

<http://www.energycodes.gov>

## ASHRAE STANDARD 90.2-2007 Energy-Efficient Design of New Low-Rise Residential Buildings

American Society of Heating, Refrigerating and Air-Conditioning Engineers, Inc.

1791 Tullie Circle, NE

Atlanta, GA 30329

<http://www.ashrae.org>

## Manufacturer's Associations

### Air Diffusion Council (ADC) (representing manufacturers of flexible air duct)

1901 N. Roselle Road, Suite 800

Schaumburg, Illinois 60195

Phone: 847-706-6750, Fax: 847-706-6751

<http://www.flexibleduct.org/>

### American Iron and Steel Institute

1140 Connecticut Ave., NW, Suite 705

Washington, D.C. 20036

Phone: 202-452-7100

<http://www.steel.org/>

### Cellulose Insulation Manufacturers Association (CIMA)

136 South Keowee Street

Dayton, OH 45402

Phone: 888-881-CIMA (881-2462) or 937-222-CIMA (222-2462), Fax: 937-222-5794

<http://www.cellulose.org/>

### Center for the Polyurethanes Industry

American Chemistry Council

1300 Wilson Blvd., Arlington, VA 22209

<http://www.polyurethane.org>

### Expanded Polystyrene (EPS) Molder's Association

1298 Cronson Boulevard, Suite 201

Crofton, MD 21114

Phone: 800-607-3772

<http://www.epsmolders.org>

### Extruded Polystyrene Foam Association (XPSA)

4223 Dale Boulevard

Woodbridge, VA 22193

Phone: 703-730-0062, Fax: 703-583-5860

<http://www.xpsa.com>

**Home Ventilating Institute**

1000 N. Rand Rd., Suite 214  
Wauconda, IL 60084  
Phone: 847-526-2010, Fax: 847-526-3993  
<http://www.hvi.org/>

**Insulating Concrete Form Association**

1730 Dewes Street, Suite #2  
Glenview, IL 60025  
Phone: 888-864-4232, Fax: 847-657-9728  
<http://www.forms.org/>

**North American Insulation Manufacturers Association (NAIMA)**

44 Canal Center Plaza, Suite 310  
Alexandria, VA 22314  
Phone: 703-684-0084, Fax: 703-684-0427  
<http://www.naima.org>

**Polyisocyanurate Insulation Manufacturers Association (PIMA)**

7315 Wisconsin Avenue, Suite 400E  
Washington, DC 20814  
Phone: 301-654-0000, Fax: 301-951-8401  
<http://www.pima.org>

**Reflective Insulation Manufacturers Association**

4519 E. Lone Cactus Drive  
Phoenix, AZ 85050  
Phone: 800-279-4123, Fax: 480-513-4749  
<http://www.rima.net/>

**Society of the Plastics Industry, Inc.**

1667 K St., NW, Suite 1000  
Washington, DC 20006  
Phone: 202-974-5200, Fax: 202-296-7005  
<http://www.socplas.org>

**Spray Polyurethane Foam Alliance**

4400 Fair Lakes Court, Suite 105  
Fairfax, VA 22033  
Phone: 800-523-5154, Fax: 703-222-5816  
<http://www.sprayfoam.com/>

**Structural Insulated Panel Association (SIPA)**

P.O. Box 1699  
Gig Harbor, WA 98335  
Phone: 253-858-7472, Fax: 253-858-0272  
<http://www.sips.org>



## Appendix – Related Technology Fact Sheets

- Ceiling and Attics
- Attics Access
- Wall Insulation
- Basement Insulation
- Crawlspace Insulation
- Slab Insulation
- Air Sealing
- Whole-House Ventilation Systems

# CEILING AND ATTICS

## *Install Insulation and Provide Ventilation*



### Buildings for the 21st Century

Buildings that are more energy-efficient, comfortable, and affordable...that's the goal of DOE's Office of Building Technology, State and Community Programs (BTS). To accelerate the development and wide application of energy efficiency measures, BTS:

- Conducts R&D on technologies and concepts for energy efficiency, working closely with the building industry and with manufacturers of materials, equipment, and appliances
- Promotes energy/money saving opportunities to both builders and buyers of homes and commercial buildings
- Works with State and local regulatory groups to improve building codes, appliance standards, and guidelines for efficient energy use
- Provides support and grants to States and communities for deployment of energy-efficient technologies and practices

### BENEFITS OF CEILING INSULATION

Insulating ceilings is one of the most cost-effective energy efficiency measures. In addition to reducing heat loss in the winter and heat gains in the summer, ceiling insulation improves comfort by bringing ceiling temperatures closer to room temperatures and providing an even temperature distribution throughout the house.

When planning and managing ceiling insulation projects, make sure

- Ceiling is properly sealed
- Correct insulation levels are selected
- Insulation is properly installed
- Insulation coverage is continuous and complete
- Attic ventilation is maintained

Attic floors over flat ceilings are often the easiest part of an exterior building envelope to insulate. They are usually accessible and have ample room for insulation. However, many homes use cathedral ceilings or have attic knee walls that present unique insulation requirements.

### ATTIC VENTILATION

Most building codes require roof vents to expel moisture that could cause insulation or other building materials to deteriorate during winter. In summer, ventilation may reduce roof temperatures, thus lengthening a roof's life.

However, researchers are investigating whether attic ventilation is beneficial for all climates. For years, researchers have believed the cooling benefits of ventilating a well-insulated attic are negligible. Some experts also question whether ventilation effectively removes moisture. Until

### ATTIC VENTILATION

Continuous ridge and soffit vents form an effective attic ventilation system.

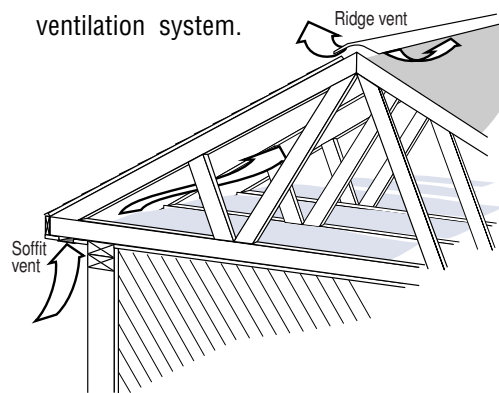

the research results are available and accepted, builders should follow local code requirements, which usually dictate attic ventilation.

A combination of continuous ridge vent along the peak of the roof and continuous soffit vents at the eaves provides the most effective ventilation. A rule of thumb is to use 1 sq. ft. of net vent opening for every 150 sq. ft. of insulated ceiling or 1:300 if the insulation has a vapor barrier. Vent area should be divided equally between the ridge and soffits.

Cap vents and gable vents can supplement a roof design that has insufficient ridge vent area. Turbine vents can also be used, although they require annual maintenance. Electrically powered roof ventilators are not recommended because they consume more energy than they save. Powered vents can also remove conditioned air from a home through ceiling leaks and bypasses, pull pollutants from the crawlspace into a home, and cause exhaust gases from fireplaces and combustion appliances to enter a home.



## ATTIC EAVES

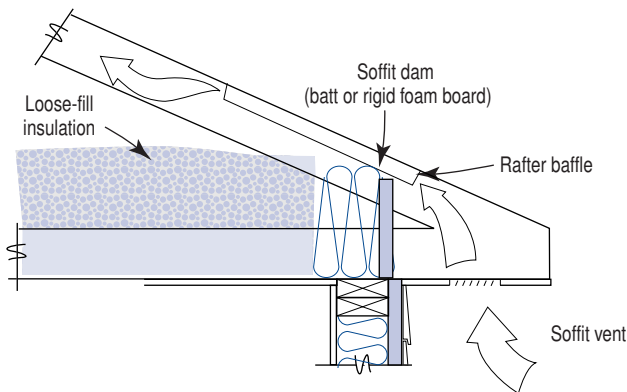

This oversized truss shows loose-fill insulation that is blocked or dammed at the eave with a soffit dam (a piece of fiberglass batt or rigid insulation). A rafter baffle creates a channel for air flow.

## INCREASING THE ROOF HEIGHT AT THE EAVE

One problem area in many roof designs occurs at the eave, where there is often insufficient space for full insulation without blocking air flow from the soffit vents. Often the insulation is compressed to fit the space, diminishing its R-value.

For a truss roof, consider *raised heel* or *oversized (cantilevered) trusses* that form elevated overhangs in combination with rafter baffles and soffit dams. These should provide clearance for both ventilation and full-height insulation. Use of 2- to 2½-foot overhangs also provides more room for insulation at the wall junction and additional window shading.

In stick-built roofs, where rafters and ceiling joists are cut and installed on the construction site, laying an additional top plate across the top of the ceiling joists at the eave will raise the roof height, prevent compression of the attic insulation, and permit ventilation. When installing a raised top plate, place a band joist at the open joist cavities of the roof framing. The band joist helps prevent windwashing of the attic insulation—where air entering the soffit vents flows through the attic insulation—which can reduce attic insulation R-values on extremely cold days or add moisture to the insulation. The band joist also serves as a soffit dam for the insulation.

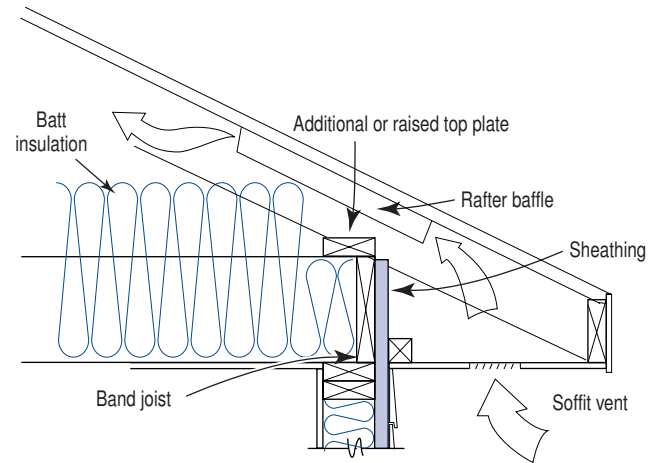

A raised top plate increases the height for insulation and ventilation at the eaves.

## CEILING INSULATION R-VALUES

The 1995 Model Energy Code (MEC) and DOE Insulation Fact Sheet provide recommended R-values for geographical locations in the continental United States. The following table provides some general guidance.

HDD Zone	Ceiling R-value
1 (0-500)	R-19
2 (501-3,000)	R-30
3 (3,001-5,000)	R-38
4 (5,001-6,000)	R-38
5 (6,001-10,000)	R-49

### HDD=HEATING DEGREE DAYS

(Consult your local weather bureau for your city's actual annual heating degree days.)

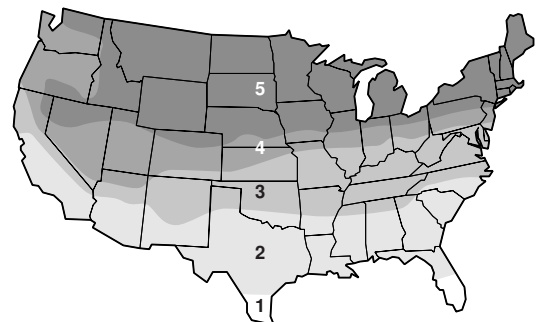

# CEILING AND ATTICS

## ATTIC INSULATION TECHNIQUES

Loose-fill or batt insulation is typically installed in an attic. Although installation costs may vary, blowing loose-fill attic insulation—fiberglass, rock wool, or cellulose—is usually less expensive than installing batts and provides better coverage.

### STEPS FOR INSTALLING LOOSE-FILL AND BATT INSULATION

1. Seal all attic-to-home air leaks, especially chases, dropped ceilings, wiring and plumbing penetrations, light fixtures, and bathroom fans. Most insulation does not stop air flow.
2. Install blocking (metal flashing) to maintain clearance requirements (usually 3 inches) for heat-producing equipment found in an attic, such as flues, chimneys, and exhaust fans.
3. Use only IC-rated recessed lights because they are airtight and can be covered with insulation.
4. Select insulation levels in accordance with the 1995 MEC or the DOE Insulation Fact Sheet. The Insulation Fact Sheet (DOE/CE-0180) can be ordered from the Energy Efficiency and Renewable Energy Clearinghouse or accessed from the Internet at [www.ornl.gov/roofs+walls](http://www.ornl.gov/roofs+walls).
5. Locate the attic access in an unconditioned part of the house if possible. Otherwise, weatherstrip the attic access and insulate it by attaching insulation to the cover or by installing an insulated cover box.
6. If mechanical equipment or storage areas are located in the attic, elevate the attic decking to allow full-height insulation to be installed.

### ADDITIONAL STEPS FOR INSTALLING LOOSE-FILL INSULATION

1. Prior to hanging ceiling drywall, install rafter baffles to preserve ventilation from soffit vents and use insulation dams

at the soffit, porch, garage, and attic access to prevent the insulation from spilling.

2. Follow the manufacturer's specifications (number of bags per square feet) to obtain complete coverage of the blown insulation at consistent depths and to avoid fluffing the insulation.
3. As required by the 1995 MEC, make sure the installer:
  - Provides attic rulers to show proper blown depth (facing the attic entrance, one ruler for every 300 sq. ft.)
  - Provides an accurate attic "report card" showing that sufficient density was installed

### ADDITIONAL STEPS FOR INSTALLING BATT INSULATION

1. Cover the top of the ceiling joists or the bottom cord of the truss with insulation.
2. Obtain complete coverage of full-thickness, non-compressed insulation. Make certain batts completely fill the joist cavities. Shake batts to ensure proper loft. If joist spacing is uneven, patch gaps in the insulation with scrap pieces. Do not compress the insulation with wiring, plumbing or ductwork (cut slits in the insulation if necessary).

## ENERGY-EFFICIENT CATHEDRAL CEILINGS

Cathedral ceilings must provide space between the roof deck and ceiling for adequate insulation and ventilation. For most areas of the U.S., the 1995 MEC recommends R-25 to R-38 insulation in a cathedral ceiling. This can be achieved through the use of truss joists, scissor truss framing, or sufficiently large rafters. For example, cathedral ceilings built with 2x12 rafters have space for standard 10-inch, R-30 batts and ventilation.

## ATTIC ACCESS

When the attic access is located in the conditioned space of the house, build an insulated attic access cover to provide continuous ceiling insulation coverage and use blocking to prevent full-height, loose-fill insulation from falling through the access.

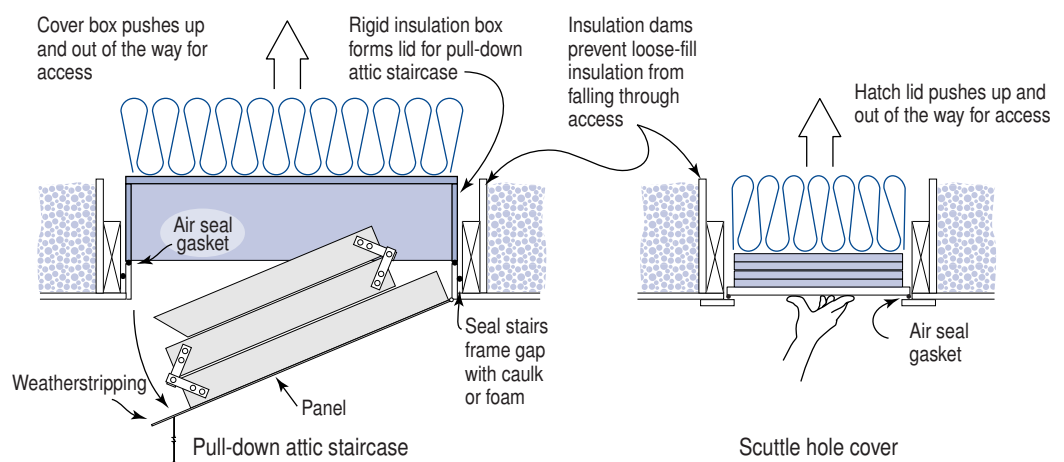

# CEILING AND ATTICS

For more information, contact:

**Energy Efficiency and Renewable Energy Clearinghouse (EREC)**  
1-800-DOE-3732  
[www.eren.doe.gov](http://www.eren.doe.gov)

Or visit the BTS Web site at [www.eren.doe.gov/buildings](http://www.eren.doe.gov/buildings)

Or refer to the Builder's Guide Energy Efficient Building Association, Inc.  
651-268-7585  
[www.eeba.org](http://www.eeba.org)

Written and prepared for the U.S. Department of Energy by:

**Southface Energy Institute**  
404-872-3549  
[www.southface.org](http://www.southface.org)

**Oak Ridge National Laboratory**  
Buildings Technology Center  
423-574-5178  
[www.ornl.gov/ORNL/BTC](http://www.ornl.gov/ORNL/BTC)

The Model Energy Code can be obtained from the International Code Council by calling 703-931-4533

MECcheck, a companion compliance software package, can be ordered from DOE by calling 1-800-270-CODE or downloaded directly from the Web at [www.energycodes.org/resid/resid.htm](http://www.energycodes.org/resid/resid.htm).

NOTICE: Neither the United States government nor any agency thereof, nor any of their employees, makes any warranty, express or implied, or assumes any legal liability or responsibility for the accuracy, completeness, or usefulness of any information, apparatus, product, or process disclosed. The views and opinions of authors expressed herein do not necessarily state or reflect those of the United States government or any agency thereof.

Foil-faced batt insulation is often used in cathedral ceilings because it has a 0.5 perm rating and provides the permeability often required for use in ceilings without attic spaces. A *vent baffle* should be installed between the insulation and roof decking to ensure that the ventilation channel is maintained.

If roof framing provides insufficient space for required insulation, higher insulation values can be obtained by either attaching furring strips to the underside of the rafters (that permit additional insulation to be installed), using high-density batts (high-density R-30 batts are about the same thickness as R-25 batts and fit into 2x10 framing), or adding rigid foam insulation under the rafters. Rigid foam insulation offers a resistance to thermal bridging through wood rafters. Rigid foam insulation must be covered with a fire-rated material when used on the interior of a building. Half-inch drywall usually complies, but check with local building codes for confirmation.

## KNEE WALLS

Knee walls are vertical walls with attic space directly behind them. They are often found in houses with finished attics and dormer windows, such as in story-and-a-half designs.

One approach to constructing an energy-efficient knee wall is to first air seal the knee wall using conventional techniques (i.e., seal the

bottom plate, seal penetrations through the drywall, etc.). The open joist ends below the knee wall should be plugged with squares of cardboard, metal flashing, or rigid insulation; cellulose insulation blown at a high density; or batt insulation stuffed into plastic bags. The plugs should be sealed to the joists using caulk or spray foam.

The knee wall and attic floor in the attic space behind it should be insulated to recommended levels. The same techniques for achieving higher insulation levels in cathedral ceilings can be applied to knee walls. Twine is often used to hold the batt insulation in place. The technique of adding rigid foam insulation over the framing is particularly effective. Rigid insulation can be notched to fit over the floor joists. Sealing rigid insulation to floor joists effectively blocks open floor joists.

A better approach is to insulate and air seal the rafter space along the sloping ceiling of the knee wall attic space. The rafters should receive recommended insulation levels. They should be covered with a sealed air barrier, such as drywall or foil-faced hardboard. The barrier must be caulked to the top plate of the exterior wall below the attic space and to the top plate of the knee wall itself. All other cracks and holes must be sealed as well. One advantage of this technique is that any ductwork located in this space is now inside the conditioned space.

## ATTIC KNEE WALL DESIGN

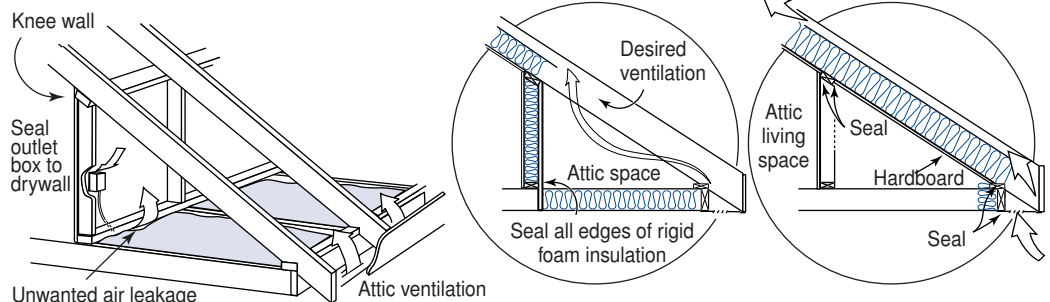

Printed with a renewable-source ink on paper containing at least 50% wastepaper, including 20% postconsumer waste.

February 2000 DOE/G010099-771



## Buildings for the 21st Century

Buildings that are more energy-efficient, comfortable, and affordable...that's the goal of DOE's Office of Building Technology, State and Community Programs (BTS). To accelerate the development and wide application of energy efficiency measures, BTS:

- Conducts R&D on technologies and concepts for energy efficiency, working closely with the building industry and with manufacturers of materials, equipment, and appliances
- Promotes energy/money saving opportunities to both builders and buyers of homes and commercial buildings
- Works with State and local regulatory groups to improve building codes, appliance standards, and guidelines for efficient energy use
- Provides support and grants to States and communities for deployment of energy-efficient technologies and practices

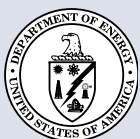

# ATTIC ACCESS

*Provide adequate insulation coverage and air sealing for the access between living space and the unconditioned attic*

## DON'T LEAVE A HOLE IN THE CEILING

A home's attic access, such as an attic hatch, pull-down stairs, or knee-wall door, often goes uninsulated, representing one of the biggest deficiencies in the thermal barrier between the attic and conditioned space. This gap in the attic insulation increases heat loss in winter and heat gain in summer, and makes indoor living areas uncomfortable.

Such accesses are often not sealed properly. A ¼-inch gap around the perimeter of an attic access can potentially leak the same amount of air supplied by a typical bedroom heating duct (~100 CFM). Unsealed, the attic access in a home leaks energy dollars and causes the house to be less comfortable.

## ATTIC ACCESS

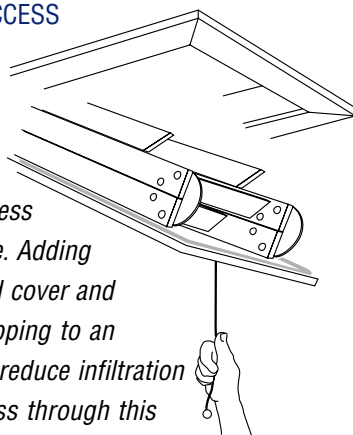

*An attic access is a big hole. Adding an insulated cover and weatherstripping to an access can reduce infiltration and heat-loss through this passageway. Latch bolts (not shown) may be installed to help ensure an even tighter seal.*

## ATTIC HATCH

One inexpensive and common type of attic access is referred to as a *scuttle hole* or *attic hatch*, which is simply a removable portion of the ceiling that allows entry to the attic above. A scuttle hole is commonly located in a closet or main hallway.

## SCUTTLE HOLE COVER

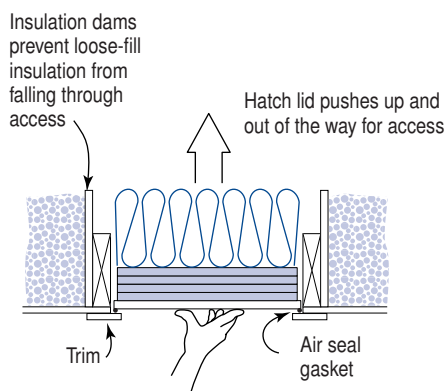

To create the hatch, the installer should cut a plywood piece or save the ceiling drywall piece that is cut out for the hole. To ensure a tight fit, securely fasten the trim around the hole to the ceiling and make sure that it is flat and level. An uneven base can cause air leakage. Weatherstripping can be installed either on the hatch itself or on the inside of the trim or base where the hatch rests. Adding a latch bolt will help ensure a tighter seal.

After the trim or base is aligned to seal properly, insulation should be added to the attic side of the hatch. Rigid insulated sheathing is recommended. Cut the insulated sheathing ¼ inch smaller than the hatch size to allow for clearance when moving the access panel. Apply 3 or 4 inches of insulation to the hatch with construction adhesive and screws. As an added measure, glue the kraft-paper side of batt insulation to the top of the last layer of rigid insulation. Try to achieve the same total R-value as recommended by the 1995 Model Energy Code (MEC)(see page 4) or DOE Insulation Fact Sheet. Order the Insulation Fact Sheet (DOE/CE-0180) from the Energy Efficiency and Renewable Energy Clearinghouse or access it from the Internet at [www.ornl.gov/roofs+walls](http://www.ornl.gov/roofs+walls).

## PULL-DOWN ATTIC STAIRS

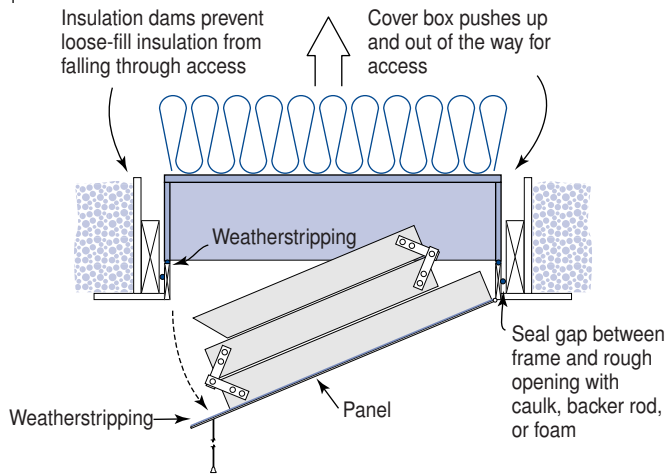

*An attic stair cover box is made from rigid insulation. It drops down from the attic side to seal and insulate the pull-down stairs.*

## ATTIC STAIRS

Pull-down stairs are another common type of attic access. The frame for the stairs fits in a rough opening and leaves a gap, much like that for a door or window, which must be sealed. If the gap is small (less than  $\frac{1}{2}$  inch), caulk can be used as the sealant. If a larger opening exists, then non-expanding foam or a backing material (backer rod) is recommended in conjunction with caulk. Expanding foam can be used, but care must be taken because of its highly expansive nature; it could warp the frame and interfere with the ability of the stairs to open or close properly. To ensure a tight fit between the stairs' flat panel and the frame, weatherstripping or gasket material should be added either to the frame or the panel. Latch bolts may be installed to help ensure a tighter seal.

To insulate attic stairs access, a lightweight, moveable box can be constructed from rigid foam or fibrous ductboard to fit over the stairs from the attic side. Insulating kits are also available through weatherization suppliers or from local hardware stores.

As with all home projects, follow the attic stairs manufacturer's instructions for proper installation. Manufacturer's guidelines often provide unique techniques and safety considerations for each particular unit. For safety and the extended life of the stairs, be sure to cut the stairs to the proper length. This action will prevent strain on the hinges and reduce wear on the pivotal joints of the stairs.

## ATTIC ACCESS LOCATION

Location of an attic access is important. If possible, locate the access in an unconditioned part of the house (e.g., garage, covered patio, or porch) that is also secure against potential break-ins. A garage location, where the vented attic is uninsulated, can eliminate the need for sealing and insulation.

For a pull-down attic staircase, make sure that opening the stairs will not interfere with the placement of furniture. The position of the staircase in relation to ceiling joists might also affect location—placing the staircase between joists instead of across joists can speed installation because structural cross-member framing is not as complicated.

## ATTIC DECKING

Attic decking is often used to provide additional storage space or a platform for an HVAC unit or hot water tank installed in the attic. The decking is often installed directly on top of the ceiling joists; this limits the amount of space available for insulation and lowers the attic's average R-value.

To ensure proper insulation depth, the attic decking must be raised above the ceiling joists. To accomplish this "edge-nail" 2x4's or 2x6's to the tops of the ceiling joists where the decking is to be located or, as an option for trusses, lag 2x4 members to the truss webbing at the desired height. Install the decking securely to the top of the raised lumber after the insulation has been installed.

## INCREASE ATTIC INSULATION LEVELS UNDER DECKING

*For many products, an insulation depth of 10 to 14 inches is needed to achieve an R-30 to R-38 insulation value. Thus, a 2x4 or 2x6 extension needs to be added to a 2x6 joist to provide sufficient depth before installing decking.*

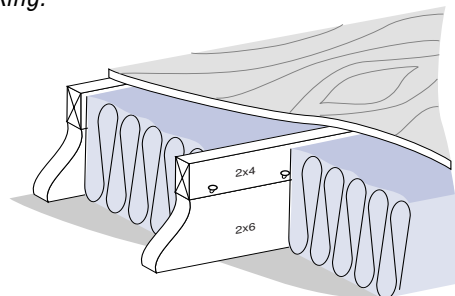

# ATTIC ACCESS

## CONSTRUCT AN ATTIC STAIRS COVER BOX

Use the template shown here to cut pieces from a single 4x8 foot sheet of ½-inch rigid insulation for a box 53½ inches long (51½ inches inside), 24¾ inches wide (22¾ inches inside), and 9 inches high inside. This box will fit stairs with an outside framing dimension of 53½ inches by 24¾ inches. Adjust dimensions to fit the specific stairs being installed. Be sure to carefully measure both inside and outside dimensions to the appropriate length, width, and depth clearances for the cover box.

Create the box as shown: Apply adhesive/mastic and use roofing nails to construct the two end and two side pieces. Assemble the side and end pieces into a box using adhesive and longer nails. Add the center support brace and cover piece with glue and nails. A faced insulation batt may be glued to the cover piece with adhesive applied to the paper backing.

### ✓ MATERIALS NEEDED:

- ½-inch rigid insulation
- Insulation batt (optional)
- Duct sealing mastic or construction adhesive
- 1-inch roofing nails (8d or 16d)
- Tape measure, sharp utility knife and straight-edge, or table/circular saw
- Weatherstripping/gasket material with adhesive

## ATTIC STAIRS COVER BOX

Pay careful attention to inside and outside dimensions plus height requirements for the specific measurements of the attic staircase being installed. The cover box should rest squarely on top of the attic stairs frame. Shim and seal the gap between the frame and rough opening and install weatherstripping.

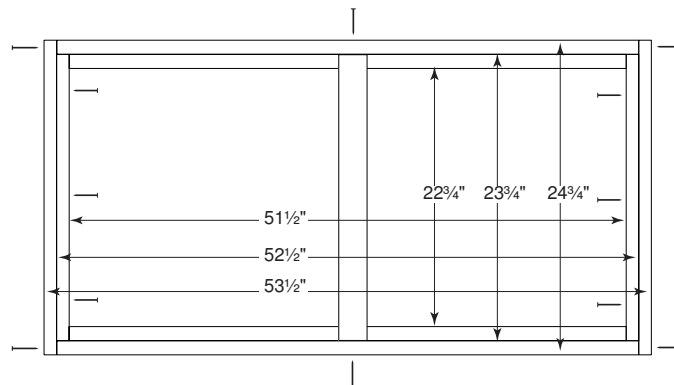
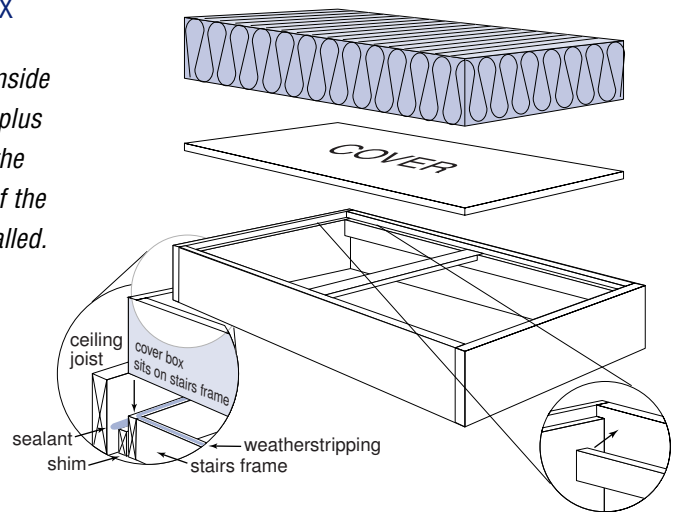

Assemble side pieces, end pieces, and brace as shown. The cover piece will drop in and be attached with adhesive and nails.

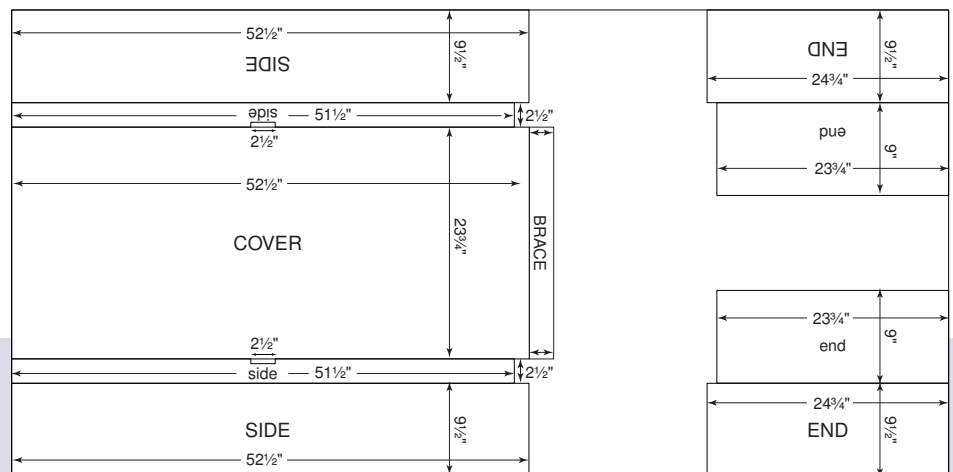

All pieces can be cut out of one 4'x8' sheet of rigid insulation. Use a table saw for smooth, accurate cuts.



# ATTIC ACCESS

For more information, contact:

**Energy Efficiency and Renewable Energy Clearinghouse (EREC)**  
1-800-DOE-3732  
[www.eren.doe.gov](http://www.eren.doe.gov)

Or visit the BTS Web site at  
[www.eren.doe.gov/buildings](http://www.eren.doe.gov/buildings)

Or refer to the Builder's Guide Energy Efficient Building Association, Inc.  
651-268-7585  
[www.eeba.org](http://www.eeba.org)

Written and prepared for the U.S. Department of Energy by:

**Southface Energy Institute**  
404-872-3549  
[www.southface.org](http://www.southface.org)

**Oak Ridge National Laboratory**  
Buildings Technology Center  
423-574-5178  
[www.ornl.gov/ornl/btc](http://www.ornl.gov/ornl/btc)

The Model Energy Code can be obtained from the International Code Council by calling 703-931-4533

MECcheck, a companion compliance software package, can be ordered from DOE by calling 1-800-270-CODE or downloaded directly from the Web at [www.energycodes.org/resid/resid.htm](http://www.energycodes.org/resid/resid.htm).

NOTICE: Neither the United States government nor any agency thereof, nor any of their employees, makes any warranty, express or implied, or assumes any legal liability or responsibility for the accuracy, completeness, or usefulness of any information, apparatus, product, or process disclosed. The views and opinions of authors expressed herein do not necessarily state or reflect those of the United States government or any agency thereof.

## ATTIC KNEE WALL

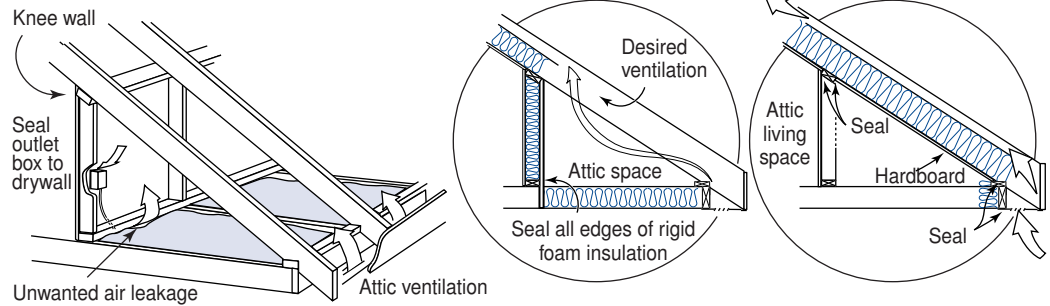

The attic knee wall is often underinsulated and leaky. Install adequate insulation and air seal around the living space for continuity in the building envelope when addressing the knee-wall door.

## KNEE WALLS

Another type of attic access is a knee-wall door. A knee wall is typically a partial height wall that is usually found in the upstairs level of finished-attic homes. Knee walls are notoriously leaky and often poorly insulated. Make sure that the knee-wall door is weatherstripped and has a latch that pulls it tightly against the frame and weatherstripping to achieve a solid seal. Use construction adhesive and screws to attach rigid insulation to the attic side of the door. Some attic doors are full-height interior doors which should be insulated, weatherstripped, and equipped with a tight threshold.

Inspect the rest of the knee wall and adjust insulation levels to meet those recommended in the 1995 MEC or DOE Insulation Fact Sheet. If not enough insulation is installed, first air seal the knee wall before insulating. Consider covering the back of the vertical knee wall with rigid insulation. Insulated sheathing, with the seams caulked or sealed with housewrap tape, reduces heat flow and minimizes the comfort problems commonly associated with drafty attic knee walls.

In new construction, an improved approach is to insulate and air seal the rafter space along

the sloped ceiling of the knee wall. The rafters should be covered with a sealed air barrier, such as drywall, rigid insulation, or foil-faced hardboard. One advantage of this approach is that the storage area as well as any ductwork is now inside a more tempered space.

## KNEE-WALL DOOR

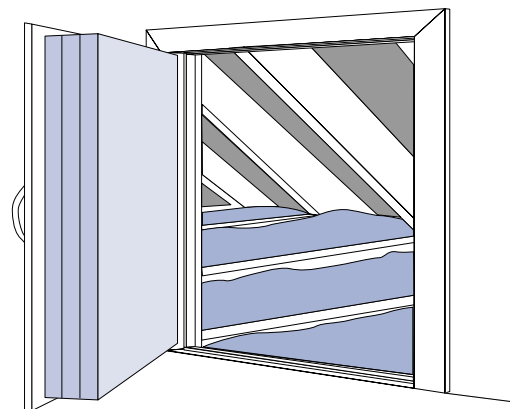

Add R-value to a knee-wall door by adhering rigid insulation boards (sandwiched together with construction adhesive and screws) to the back of the door. Pay special attention to the clearance between the insulation and the door frame and air sealing details.



Printed with a renewable-source ink on paper containing at least 50% wastepaper, including 20% postconsumer waste.

February 2000 DOE/G010099-768

# WALL INSULATION

## *Provide Moisture Control and Insulation in Wall Systems*



### Buildings for the 21st Century

Buildings that are more energy efficient, comfortable, and affordable...that's the goal of DOE's Office of Building Technology, State and Community Programs (BTS). To accelerate the development and wide application of energy efficiency measures, BTS:

- Conducts R&D on technologies and concepts for energy efficiency, working closely with the building industry and with manufacturers of materials, equipment, and appliances
- Promotes energy/money saving opportunities to both builders and buyers of homes and commercial buildings
- Works with state and local regulatory groups to improve building codes, appliance standards, and guidelines for efficient energy use
- Provides support and grants to states and communities for deployment of energy-efficient technologies and practices

### EFFECTIVE WALL INSULATION

Properly sealed, moisture-protected, and insulated walls help increase comfort, reduce noise, and save on energy costs. However, walls are the most complex component of the building envelope to insulate, air seal, and control moisture.

The keys to an effective wall are:

- Airtight construction—all air leaks sealed in the wall during construction and prior to insulation installation.
- Moisture control—exterior rain drainage system, continuous air barrier, and vapor barrier located on the appropriate side of the wall.
- Complete insulation coverage—advanced framing to maximize insulation coverage and reduce thermal bridging, no gaps or compressed insulation, and continuous insulated sheathing.

### AIR SEALING

Air sealing reduces heat flow from air movement (convection) and prevents water vapor in the air from entering the wall. In a 100-square-foot wall, one cup of water can diffuse through drywall without a vapor barrier in a year, but 50 cups can enter through a 1/2-inch, round hole. In fact, sealing air leaks is 10 to 100 times as important as installing a vapor barrier.

### MOISTURE CONTROL

Air sealing and moisture control make insulation more effective. It is a myth that installing vapor barriers is the most important step for controlling moisture in walls. Vapor barriers only retard moisture due to diffusion, while most moisture enters walls either through fluid capillary action or as water vapor through air leaks.

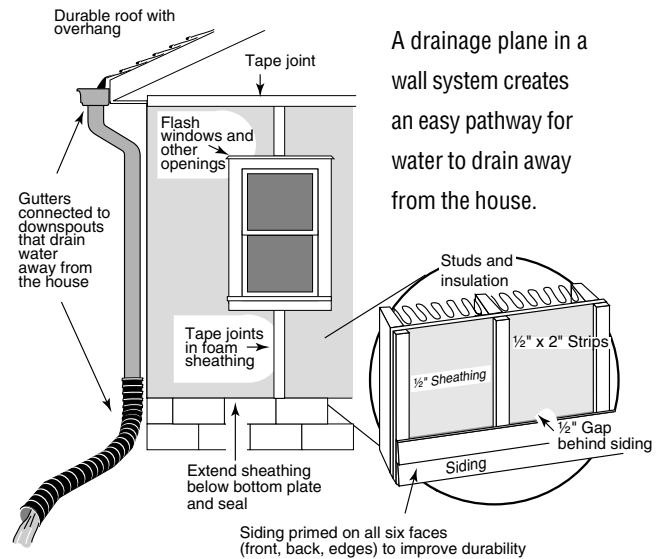

A drainage plane in a wall system creates an easy pathway for water to drain away from the house.

### ✓ PREVENT RAIN PENETRATION

Causes of rain leaks through exterior walls include improper installation of siding materials; poor-quality flashing, weatherstripping, or caulking around joints in the building exterior (such as windows, doors, and bottom plates); and wind-driven rain that penetrates the exterior finish. To enhance protection against rain penetration, create a drainage plane within the wall system of the home.

### ✓ CONTROL MOISTURE IN WALLS

All climates require these steps:

- Install a polyethylene ground cover on the earth floor of houses with crawl spaces and slope the ground away from the foundations of all houses.
- Install a continuous vapor barrier that has a Perm rating of less than one (see page 3).
- Place a termite shield, sill gaskets, or other vapor-impermeable membrane on the top of the foundation wall. This action will prevent moisture from wicking into the framed wall from the concrete foundation wall by capillary action.



## WALL FRAMING WITH ADVANCED FRAMING TECHNIQUES

Building experts have performed considerable research on ways to reduce the amount of lumber in our homes while maintaining structural integrity. The U.S. Forestry Products Association and other organizations have devised an “optimum value engineering” (OVE) framing system that reduces unnecessary lumber use and improves the whole-wall R-value by reducing thermal bridging and maximizing the wall area that is insulated. Selected OVE practices include:

- Design the house to use materials efficiently by employing simpler shapes and volumes, compact designs, and designs based on a 2-foot module.
- Frame at 24-inch rather than 16-inch centers.
- Design headers for loading conditions and use insulated headers.
- Locate window and door openings in-line with established framing and size windows to fit within existing stud spacing.
- Eliminate unnecessary framing at intersections using two-stud rather than three-stud corners and ladder blocking where interior partitions intersect exterior walls.
- Use let-in bracing to allow the use of insulated sheathing in corners.
- Eliminate curtailed studs (cripples) under windows.
- Align roof, wall, and floor framing members (studs and joists) vertically throughout the structure so that a single top plate can be used.

## INSULATED HEADERS AND LET-IN BRACING

### Insulated headers

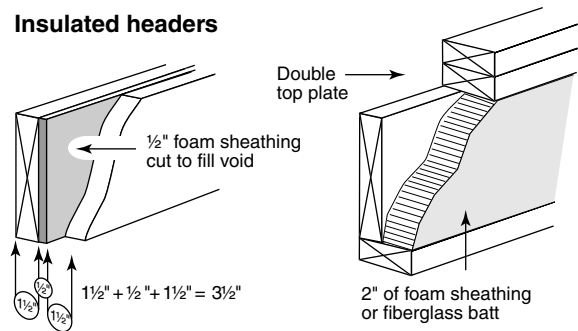

### Let-in bracing

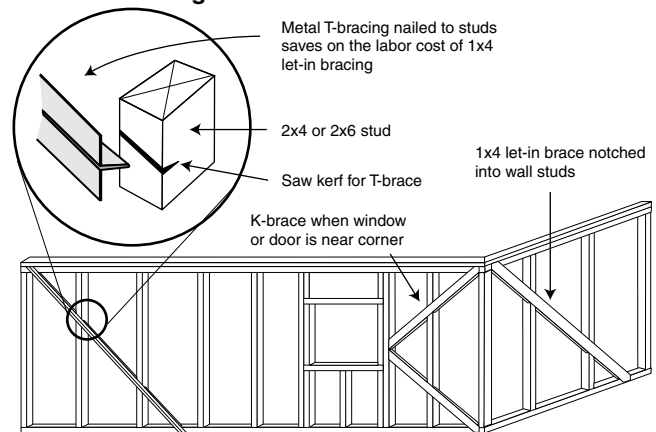

## STANDARD FRAMING VERSUS ADVANCED FRAMING CROSS-SECTION

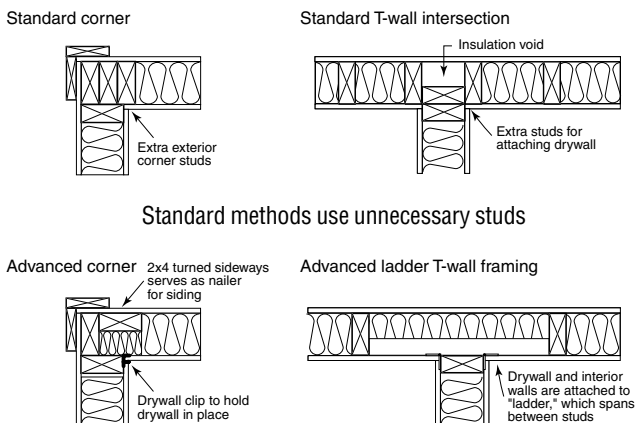

Standard methods use unnecessary studs

Comparison	Standard	Advanced
Insulation Voids	3%	0%
Framing factor	15-25%	10-15%
Batt R-value	R-13	R-13
Sheathing R-value	R-0.5 to 2.0	R-2.5
Effective Average R-value	R-11.1	R-14.6 (30% higher)

## 2X6 WALL CONSTRUCTION

In most code jurisdictions, 2x6's can be spaced on 24-inch centers, rather than 16-inch centers used for 2x4's. The advantages of using 2x6 studs on 24-inch centers are:

- The thicker wall cavity provides room for R-19 or R-21 wall insulation.
- Overall, thermal bridging through studs is reduced due to the higher R-value of 2x6's and less stud area in the wall.
- Less framing reduces labor costs.
- There is more space for insulating around piping, wiring, and ductwork.

The economics of 2x6 wall construction is favorable primarily in areas with significant winters and homes in which windows and doors occupy 10 percent or less of the total wall area. Walls with substantial window and door area may require almost as much framing as 2x4 walls because each opening can add extra studs. Additionally, the window and door jambs must be wider, requiring the purchase of a jamb extender that increases costs by \$12 to \$15 per opening.

Thicker insulated sheathing may be a less expensive way to increase overall R-value than 2x6 construction, especially in

# WALL INSULATION

homes with more window and door area. Another factor to consider is that the interior finish or exterior siding may bow slightly between studs when using 24-inch centers.

## WHAT TYPE OF INSULATION SHOULD I USE?

The home designer has an increasing array of insulation products from which to choose to insulate wood-framed walls. The wide variety of insulation materials often makes it difficult to determine the most cost-effective products and techniques. Refer to the Model Energy Code (MEC) or DOE Insulation Fact Sheet for R-value recommendations for your climate and building type. The DOE Insulation Fact Sheet (DOE/CE-0180) can be ordered from the Energy Efficiency and Renewable Energy Clearinghouse or accessed from the Internet at [www.ornl.gov/roofs+walls](http://www.ornl.gov/roofs+walls).

- *Fiberglass and rock wool batts*—2x4 walls can hold R-13 or R-15 batts; 2x6 walls can have R-19 or R-21 products. Generally, batt insulation is the least expensive wall insulation material but requires careful installation for effective performance (see page 4).
- *Cellulose insulation*, made from recycled newsprint, comes primarily in loose-fill form. It can be installed in walls using a dry-pack process or a moist-spray technique. It generally costs more than batt insulation, but it offers reduced air leakage through the wall cavity plus improved sound deadening.
- *Fiberglass and rock wool loose-fill insulation* provide full coverage with a “Blow-in Blanket” System (BIBS) that involves blowing insulation into open stud cavities behind a net.
- *Rigid foam insulation* has a higher R-value per inch than fiberglass or cellulose and stops air leaks, but it is considerably more expensive. It is manufactured in sheet-good dimensions and is often used as the outer layer of insulation.

- *Foam-in-place insulation* can be blown into walls and reduces air leakage. Some types use carbon dioxide in the manufacturing process rather than more environmentally harmful gases such as pentane or hydrochlorofluorocarbons.

## WALL SHEATHINGS

Some builders use ½-inch wood sheathing (R-0.6) or asphalt-impregnated sheathing, usually called blackboard (R-1.3), to cover the exterior framing before installing siding. Instead, consider using ½-inch foam insulated sheathing (R-2 to R-3.5). Sheathing thicker than ½ inch will yield even higher R-values.

Foam sheathing has these advantages:

- The continuous layer of insulation reduces thermal bridging through wood studs, saving energy and improving comfort.
- It is easier to cut and install than heavier weight sheathing products.
- It protects against condensation on the inside wall by keeping the interior of the wall warmer.
- It usually costs less than plywood or oriented strand board (OSB).

Ensure that the sheathing completely covers, and is sealed to, the top plate and band joist at the floor. Most sheathing products come in 8-, 9-, or 10-foot lengths to allow complete coverage of the wall. Once it is installed, patch all holes, penetrations, and seams with caulk or housewrap tape.

Because of its insulation advantages over plywood and OSB, foam sheathing is best when used continuously in combination with let-in bracing, which provides structural support similar to that offered by plywood or OSB. Some builders use two layers of sheathing—plywood or OSB for structural support and a seam-staggered layer of rigid foam for insulation. When the total depth of the sheathing material exceeds ½ inch, make certain the window and door jambs are adjusted for the total wall thickness. Some flanged windows are readily adaptable to this approach.

## VAPOR BARRIER PLACEMENT BY GEOGRAPHICAL LOCATION

In most cold climates, vapor barriers should be placed on the interior (warm-in-winter) side of walls. However, the map shows that in some southern climates, the vapor barrier should be omitted, while in hot and humid climates, such as along the Gulf coast and in Florida, the vapor barrier should be placed on the exterior of the wall.

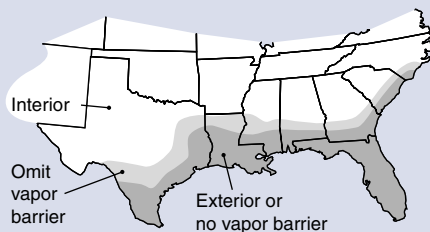

## Perm Ratings of Different Materials

(Rating of 1 or less qualifies as a vapor barrier)

Asphalt-coated paper backing on insulation	0.40
Polyethylene plastic (6 mil)	0.06
Plywood with exterior glue	0.70
Plastic-coated insulated foam sheathing	0.4 to 1.2
Aluminum foil (.35 mil)	0.05
Vapor barrier paint or primer	0.45
Drywall (unpainted)	50
Drywall (painted - latex paint)	2-3

# WALL INSULATION

For more information, contact:

**Energy Efficiency and Renewable Energy Clearinghouse (EREC)**  
1-800-DOE-3732  
www.eren.doe.gov

Or visit the BTS Web site at  
www.eren.doe.gov/buildings

Or refer to the Builder's Guide Energy Efficient Building Association, Inc.  
651-268-7585  
www.eeba.org

Written and prepared for the U.S. Department of Energy by:

**Southface Energy Institute**  
404-872-3549  
www.southface.org

**U.S. Department of Energy's Oak Ridge National Laboratory**  
Buildings Technology Center  
423-574-5178  
www.ornl.gov/ORNL/BTC

The Model Energy Code can be obtained from the International Code Council by calling 703-931-4533

MECcheck, a companion compliance software package, can be ordered from DOE by calling 1-800-270-CODE or downloaded directly from the Web at www.energycodes.org/resid/resid.htm.

*NOTICE: Neither the United States government nor any agency thereof, nor any of their employees, makes any warranty, express or implied, or assumes any legal liability or responsibility for the accuracy, completeness, or usefulness of any information, apparatus, product, or process disclosed. The views and opinions of authors expressed herein do not necessarily state or reflect those of the United States government or any agency thereof.*

## STEPS FOR EFFECTIVE WALL CONSTRUCTION AND INSULATION

1. Review the plans and specifications and identify all walls (including bandjoists) between conditioned (heated and cooled) spaces and unconditioned spaces (exterior, attics, crawl spaces, garages, and mechanical rooms). Use advanced framing techniques to increase insulation levels and reduce lumber use.
2. Use diagonal corner bracing (let-in bracing) on exterior walls to substitute for corner plywood sheathing and allow continuous insulated sheathing.
3. Use foam sheathing for insulating headers to reduce framing heat loss.
4. Seal all air leaks through walls before insulating, including under the bottom plate, band joist areas between floors, electrical boxes, and all electrical, plumbing, and HVAC penetrations.
5. Use caulk and backer rod or non-expanding spray foam, not insulation, to seal around window and door jambs.
6. If fixtures such as stairs or shower/tub enclosures cover exterior walls and do not allow easy installation of insulation after the sheathing is attached, insulate behind these components in advance using R-13 or R-19 batts and cover with a weatherproof barrier (½-inch drywall, plastic, or other sheet material).
7. Select insulation levels based on the MEC and the DOE Insulation Fact Sheet.
8. Face-staple batts because side stapling creates channels for air flow and compresses the insulation, thus reducing the R-value. If face stapling is not an option, use unfaced batts or carefully side staple within ¼ inch of the stud face.

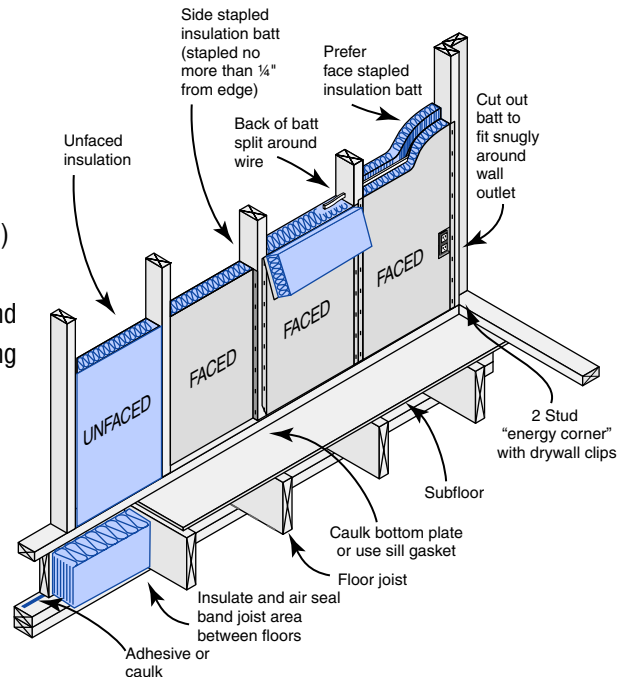

9. Obtain full coverage of batt or blown wall insulation. Cut batt insulation to fit snugly into non-standard stud spaces and to completely fill cavity.
10. Slit batt insulation to fit around the back and front side of electrical wiring and plumbing without compressing or tearing the insulation.
11. Notch out batt insulation around electrical boxes and use scraps to insulate behind the box.
12. Once the interior drywall is in place, seal all penetrations with durable caulking.

### Fiberglass Batt Insulation Characteristics

Thickness (inches)	R-value	Cost (¢/sq.ft.)
3½	11	12-16
3¾	13	15-20
3½	15 (high density)	34-40
6 to 6¼	19	27-34
5¼	21 (high density)	33-39
8 to 8½	25	37-45
8	30 (high density)	45-49
9½	30 (standard)	39-43
12	38	55-60

This chart is for comparison only. Determine actual thickness, R-value, and cost from manufacturer or local building supply.



Printed with a renewable-source ink on paper containing at least 50% wastepaper, including 20% postconsumer waste.

October 2000 DOE/GO-102000-0772



### Buildings for the 21st Century

Buildings that are more energy efficient, comfortable, and affordable...that's the goal of DOE's Office of Building Technology, State and Community Programs (BTS). To accelerate the development and wide application of energy efficiency measures, BTS:

- Conducts R&D on technologies and concepts for energy efficiency, working closely with the building industry and with manufacturers of materials, equipment, and appliances
- Promotes energy/money saving opportunities to both builders and buyers of homes and commercial buildings
- Works with state and local regulatory groups to improve building codes, appliance standards, and guidelines for efficient energy use
- Provides support and grants to states and communities for deployment of energy-efficient technologies and practices



# BASEMENT INSULATION

*Create a comfortable basement environment that is free of moisture problems and easy to condition*

### INTRODUCTION

The primary foundations in the United States are slab-on-grade, crawlspace, and basement. Basements can be a good choice for sites that slope steeply and in climates having cold winters with deep frost penetration. Although deeper excavation is required for structural reasons, the additional cost can result in a comfortable and habitable space.

Basements are notorious for problems with water intrusion, cold temperatures, humidity, mold, and uncomfortable, if not unhealthy, living conditions. A properly sealed, insulated, and moisture-protected basement will increase comfort, save on energy costs, improve durability, and reduce entry of moisture, soil gases, and other potential irritants or pollutants into the home.

However, basement walls are one of the most controversial areas of a home to insulate and seal. Many builders, even in far northern states, feel that insulating basement walls is

too expensive and does not provide a reasonable payback. Also, builders of daylight or walkout basements often only insulate the framed section of the basement. Yet energy codes typically require a thermal boundary between the house and unconditioned basement or between a conditioned basement and the outside air and earth.

### KEYS TO AN EFFECTIVE BASEMENT

**Moisture control** – using a water-managed foundation system to drain rainwater and groundwater away from foundations.

**Airtight construction** – sealing all air leaks between the conditioned space and the outside prior to insulation installation.

**Complete insulation coverage** – properly installing the correct insulation levels, making sure the insulation coverage is continuous and complete, and aligning the insulation barrier with the air barrier.

### ANNUAL SAVINGS WITH BASEMENT WALL INSULATION

The energy savings of basement wall insulation vary depending on the local climate, type of heating system, cost of energy, and lifestyle of the occupant. Typical annual savings are provided in the table for a standard, 1,500 square-foot home with a conditioned basement that is heated by natural gas (\$0.72/therm).

U.S. Cities	R-10*	R-20**
Buffalo, NY	\$350	\$390
Denver, CO	\$310	\$360
Minneapolis, MN	\$400	\$450
Seattle, WA	\$280	\$320
St. Louis, MO	\$250	\$290
Washington, DC	\$250	\$280

\* Such as 2 to 3 inches of exterior foam insulation.  
 \*\* Such as with most insulated concrete forms.

## MOISTURE FLOW IN BASEMENTS

Water forces attack a basement foundation at several points. It is key to deter water at these entry points to preserve the integrity of the dwelling and enhance the living environment.

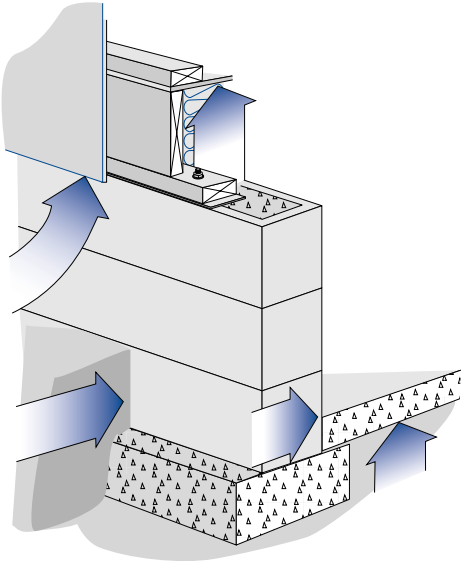

## WATER-MANAGED BASEMENT WALL AND FOUNDATION

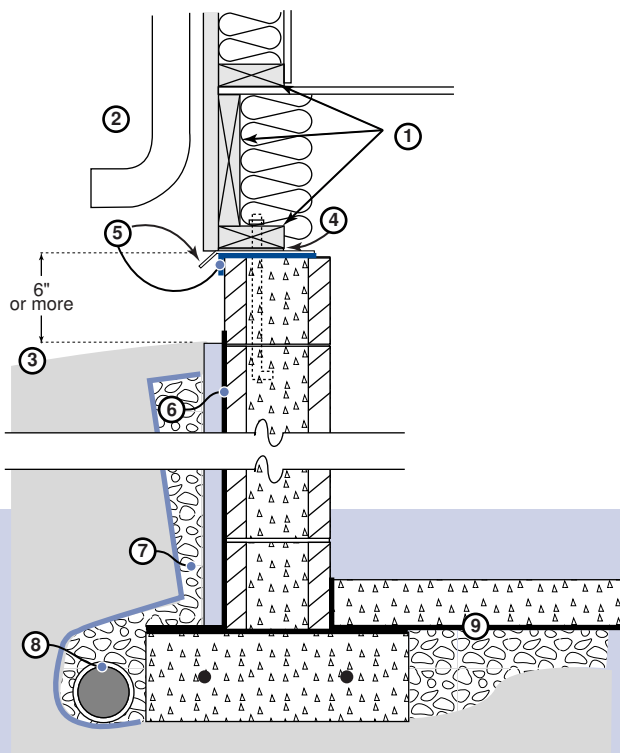

## WATER-MANAGED FOUNDATION SYSTEM

Most basement water leakage is due to either bulk moisture leaks or capillary action. Bulk moisture is the flow of water through holes, cracks, and other discontinuities into the home's basement walls. Capillary action occurs when water wicks into the cracks and pores of porous building materials, such as masonry block, concrete, or wood. These tiny cracks and pores can absorb water in any direction—even upward.

The best approaches for preventing these problems will depend on the local climate and style of construction, but the following general rules apply to most basement designs.

1. Keep all untreated wood materials away from earth contact.
2. Provide drainage, such as gutters, to conduct rainwater away from the house.
3. Slope the earth away from all sides of the house for at least 5 feet at a minimum 5% grade (3 inches in 5 feet). Establish drainage swales to direct rainwater around the house.
4. Add a sill gasket to provide air sealing.
5. Install a protective membrane, such as caulked metal flashing or EPDM-type membrane, to serve as a capillary break that reduces wicking of water up from the masonry foundation wall. This membrane can also serve as a termite shield on top of the insulation board.
6. Dampproof all below-grade portions of the foundation wall and footing to prevent the wall from absorbing ground moisture by capillary action.
7. Place a continuous drainage plane over the dampproofing or exterior insulation to channel water to the foundation drain and relieve hydrostatic pressure. Drainage plane materials include special drainage mats, high-density fiberglass insulation products, and washed gravel. All drainage planes should be protected with a filter fabric to prevent dirt from clogging the intentional gaps in the drainage material.
8. Install a foundation drain directly below the drainage plane and beside the footing, not on top of the footing. This prevents water from flowing against the seam between the footing and the foundation wall. Surround a perforated 4-inch plastic drainpipe with gravel and wrap both with filter fabric.
9. Underneath the basement's slab floor, install a capillary break and vapor retarder, consisting of a layer of 6- to 10-mil polyethylene over at least 4 inches of gravel.

# BASEMENT INSULATION

## BASEMENT INSULATION PLACEMENT

In most cases, a basement should be considered a conditioned space with insulation installed in the exterior basement walls. Even in a house with an unconditioned basement, the basement is more connected to the other living spaces of the home than to the outside. This makes basement wall insulation preferable to insulating the basement ceiling.

Advantages of basement wall insulation include:

- Basement spaces, whether conditioned or not, are warmer and more comfortable.
- Compared to insulating the basement ceiling, insulating basement walls:
  - requires less insulation (1,350 square feet of wall insulation for a 36- by 48-foot basement with 8-foot walls, compared with 1,725 square feet of basement ceiling insulation),
  - more easily achieves continuous thermal and air leakage boundaries because basement ceilings are typically penetrated with electrical wiring, plumbing, and ductwork,
  - requires little, if any increase in the size of heating and cooling equipment—the heat loss and air leakage through the basement ceiling is similar to that through the exterior walls of the basement.
- Piping and ductwork are located within the conditioned volume of the house so they do not require insulation for energy efficiency or protection against freezing.

## INTERIOR BASEMENT WALL INSULATION STRATEGIES

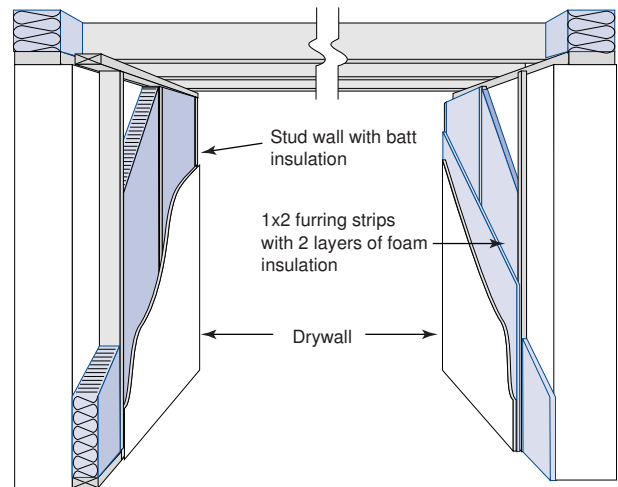

Disadvantages of basement wall insulation include:

- Costs may exceed those for insulating the basement ceiling, depending on the materials and approach selected.
- If the surrounding soil contains radon gas, the home will require a mitigation system underneath the basement floor.
- In termite-prone areas, exterior foam insulation in ground contact allows a path for termites to access the walls of the home undetected. Check with local code officials to determine acceptance of exterior foam application. Some installations will require non-invasive termite detection systems, such as termite baits. One of the nation's leading foam insulation manufacturers has released a rigid foam with borate insect repellent.

## R-VALUES RECOMMENDED FOR BASEMENT INSULATION

The International Energy Conservation Code's basement wall insulation requirements, based on Heating Degree Days (HDD), are as follows:

HDD Zone	R-value Interior	R-value Exterior
1 (0-1,500)	none	none
2 (1,501-4,500)	R-5 to R-9	R-5 to R-10
3 (4,501-8,500)	R-9 to R-10	R-10
4 (8,501-9,000)	R-10 to R-19	R-10 to R-15
5 (> 9,000)	R-19	R-15

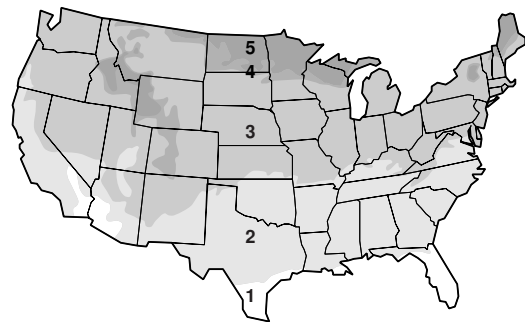

**HDD=HEATING DEGREE DAYS**

Consult your local weather bureau for your city's actual Heating Degree Days, a measurement commonly used to determine fuel consumption and/or the cost of heating during a heating season.



# BASEMENT INSULATION

For more information, contact:

**Energy Efficiency and Renewable Energy Clearinghouse (EREC)**  
1-800-DOE-3732  
[www.eren.doe.gov](http://www.eren.doe.gov)

Or visit the BTS Web site at  
[www.eren.doe.gov/buildings](http://www.eren.doe.gov/buildings)

Or refer to the Builder's Guide  
*Energy Efficient Building Association, Inc.*  
952-881-1098  
[www.eeba.org](http://www.eeba.org)

Written and prepared for  
the U.S. Department of  
Energy by:

**Southface Energy Institute**  
404-872-3549  
[www.southface.org](http://www.southface.org)

**U.S. Department of Energy's Oak Ridge National Laboratory**  
*Buildings Technology Center*  
865-574-2694  
[www.ornl.gov/ORNL/BTC](http://www.ornl.gov/ORNL/BTC)

*International Energy Conservation Code*  
can be obtained from the  
*International Code Council* by  
calling 703-931-4533  
[www.intlcode.org](http://www.intlcode.org)

*MECcheck*, a companion  
compliance software  
package, can be ordered from  
DOE by calling  
1-800-270-CODE  
or downloaded directly  
from the Web at  
[www.eren.doe.gov/buildings/  
codes\\_standards/buildings/](http://www.eren.doe.gov/buildings/codes_standards/buildings/).

*NOTICE: Neither the United States government nor any agency thereof, nor any of their employees, makes any warranty, express or implied, or assumes any legal liability or responsibility for the accuracy, completeness, or usefulness of any information, apparatus, product, or process disclosed. The views and opinions of authors expressed herein do not necessarily state or reflect those of the United States government or any agency thereof.*

## BASEMENT INSULATION TECHNIQUES

Basement insulation levels should be selected in accordance with the International Energy Conservation Code or DOE Insulation Fact Sheet (DOE/CE-0180), which can be obtained from DOE or the web at [www.ornl.gov/roofs+walls](http://www.ornl.gov/roofs+walls). Be sure to insulate both the masonry and stud walls of daylight basements.

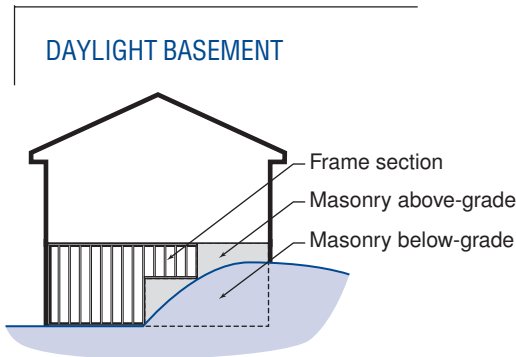

There are three primary ways to insulate the masonry portion of a basement wall:

- 1. Exterior insulation**—1 to 3 inches are recommended for most climate zones. Extruded polystyrene (R-5 per inch) is durable and moisture resistant. Expanded polystyrene (R-4 per inch) is less expensive, but it has a lower insulating value. High-density, drainable, fiberglass insulation or fibrous drainboard does not insulate as well as foam but provides a drainage plane. Leave a 6-inch gap between the insulation and wood foundation elements to provide a termite inspection area. Insulate rim joists.
- 2. Interior insulation**—usually installed behind interior framing or with furring strips placed against the foundation wall (see figure on page 3). Joints and penetrations through the drywall must be well sealed to prevent movement of moisture laden air into the insulation and possible condensation. Insulate rim joists.
- 3. Insulated Concrete Forms**—comparatively new products that are relatively easy to install. Once the hollow foam blocks are stacked, the cores are filled with concrete.

Most products provide continuous insulation on the interior and exterior. They also provide surfaces for attaching drywall, brick ties, and other finish materials. Many new insulated concrete forms are treated with termite-resistant chemicals. Insulate rim joists.

## RADON CONTROL IN BASEMENTS

Radon is a radioactive gas that occurs in some soils. It can enter a home through the foundation and floor system. If it occurs in concentrations greater than 4 pico-curies per liter, it may pose a health risk to the home occupants.

To guard against radon problems:

- Install a 4-inch or greater gravel base with a continuous layer of 6-mil polyethylene on top of the gravel.
- Embed a "T" fitting attached to a 3-inch or larger diameter gas-tight pipe through the polyethylene barrier into the sub-slab aggregate before the slab is poured.
- Pour the slab and seal all slab joints and penetrations.
- Extend the gas-tight pipe vertically through an interior wall and terminate it at least 12 inches above the roof.
- Have an electrician stub-in a junction box in the attic.
- After construction is complete, test the basement for radon with an EPA-listed radon test kit, or hire a qualified technician. If the test shows concentrations above 4 pico-curies per liter, install a small blower to the pipe in the attic to depressurize the sub-slab space. If use of the blower does not reduce radon levels below 4 pico-curies per liter, consult with local radon experts.

For more detailed instructions, visit the EPA radon web site <http://www.epa.gov/iaq/radon/>.



Printed with a renewable-source ink on paper containing at least 50% wastepaper, including 20% postconsumer waste.  
January 2002 DOE/GO-102002-0776



## Buildings for the 21st Century

Buildings that are more energy efficient, comfortable, and affordable... that's the goal of DOE's Office of Building Technology, State and Community Programs (BTS). To accelerate the development and wide application of energy efficiency measures, BTS:

- Conducts R&D on technologies and concepts for energy efficiency, working closely with the building industry and with manufacturers of materials, equipment, and appliances
- Promotes energy/money saving opportunities to both builders and buyers of homes and commercial buildings
- Works with state and local regulatory groups to improve building codes, appliance standards, and guidelines for efficient energy use
- Provides support and grants to states and communities for deployment of energy-efficient technologies and practices



# CRAWLSPACE INSULATION

*Improve comfort and increase durability in the home*

## EFFECTIVE CRAWLSPACE INSULATION

A properly sealed, moisture-protected, and insulated crawlspace will increase comfort, save on energy costs, improve the durability of the home, and reduce entry of moisture, radon, and other potential irritants or pollutants into the home. Whichever design is followed, the keys to an effective crawlspace are:

**Moisture control** –using a water-managed foundation system to drain rainwater and groundwater away from foundations.

**Airtight construction** –sealing all air leaks between the conditioned space and the outside prior to insulation installation.

**Complete insulation coverage** –properly installing the correct insulation levels and making sure the insulation coverage is continuous and complete.

## WATER-MANAGED FOUNDATION SYSTEM

A crawlspace is susceptible to moisture and deterioration problems because of contact with the earth. The best approaches for preventing these problems will depend on the local climate and style of construction, but the following general rules apply to most crawlspace designs.

1. Keep all untreated wood materials away from the earth.
2. Provide rain drainage, such as gutters, to conduct rainwater away from the house.
3. Slope the earth away from the house for at least 5 feet at a minimum 5% grade (3 inches in 5 feet). Establish drainage swales to direct rainwater around the house.
4. Add a sill gasket to provide air sealing.

## WATER-MANAGED CRAWLSPACE FOUNDATION

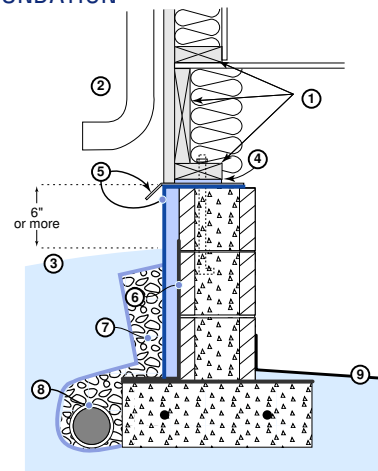

5. Install a protective membrane, such as an EPDM-type membrane, to serve as a capillary break that reduces wicking of water from the masonry wall. This membrane, in addition to metal flashing, can serve as a termite shield.
6. Dampproof the below-grade portion of the foundation wall to prevent the wall from absorbing ground moisture by capillary action.
7. Install drainage plane material or gravel against the foundation wall to relieve hydrostatic pressure and channel water to the foundation drain.
8. Provide a foundation drainage system at the bottom of the footing, not on top, when the foundation floor (interior grade) is below the exterior grade. Surround a perforated 4-inch drain pipe with gravel and cover them with filter fabric.
9. Install 6-mil polyethylene across the crawlspace floor to prevent soil moisture from migrating into the crawlspace. Overlap and tape all seams by 12 inches, and seal the polyethylene 6 inches up the crawlspace walls.

## CRAWLSPACE WALL INSULATION TECHNIQUES

For years, standard building practice was to insulate underneath the floor over a ventilated, unconditioned crawlspace. A better approach is to build a well sealed, unventilated crawlspace (i.e., build the crawlspace like a basement) by sealing and insulating the foundation walls rather than the subfloor.

Advantages to insulating the crawlspace walls are:

- Problems associated with ventilating the crawlspace are avoided.
- Less insulation is required (around 400 square feet for a 1,000-square-foot crawlspace with 3-foot walls).
- Piping and ductwork are within the conditioned volume of the house so they do not require insulation for energy efficiency or protection against freezing.
- Air sealing between the house and crawlspace is less critical.

Disadvantages to insulating the crawlspace walls are:

- The insulation may be damaged by rodents, pests, or water.

- A radon mitigation system will require ventilation of the crawlspace to the exterior. Not planning for radon-resistant construction may necessitate air sealing the floor in order to mitigate the radon through ventilation.
- The crawlspace must be built airtight and the air barrier must be maintained.
- The access door to the crawlspace must be located inside the home through the subfloor unless an airtight, insulated access door in the perimeter wall is built and maintained.

## STEPS FOR INSTALLING CRAWLSPACE WALL INSULATION

1. Review plans for this method of foundation insulation with pest control and local building officials to ensure code compliance.
2. Eliminate or seal the foundation vents.
3. Ensure that combustion furnaces and water heaters located in the crawlspace are sealed-combustion units equipped with a powered combustion system.
4. Seal all air leaks through the exterior wall during and after construction, including the band joist.

## INSULATED CRAWL SPACE WALLS—3 OPTIONS

### Option 1 Exterior foam insulation

Protective membrane covers exterior rigid insulation and folds over top course of foundation block

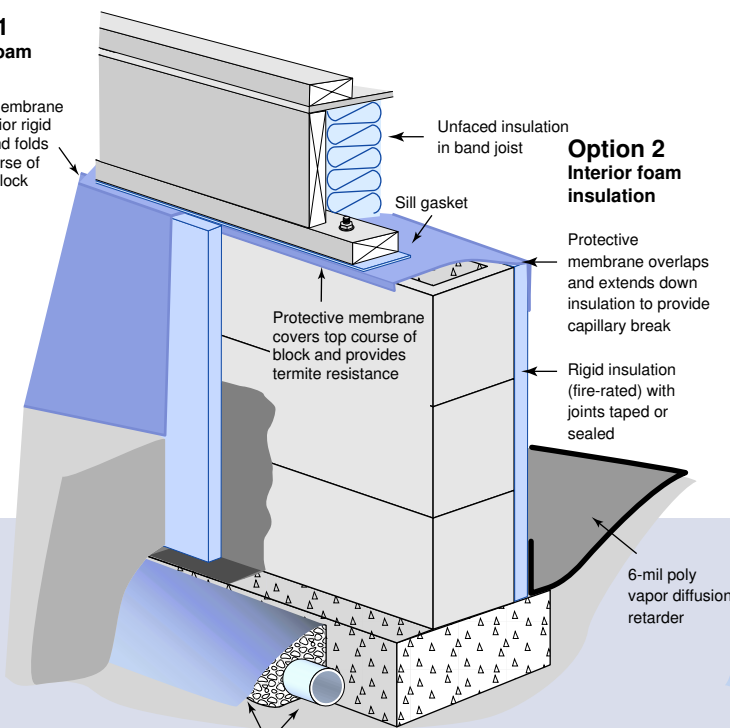

Perforated drainage pipe is embedded in gravel, covered with filter fabric, and located at lower perimeter of foundation footing to provide drainage.

### Option 2 Interior foam insulation

Protective membrane overlaps and extends down insulation to provide capillary break  
Rigid insulation (fire-rated) with joints taped or sealed

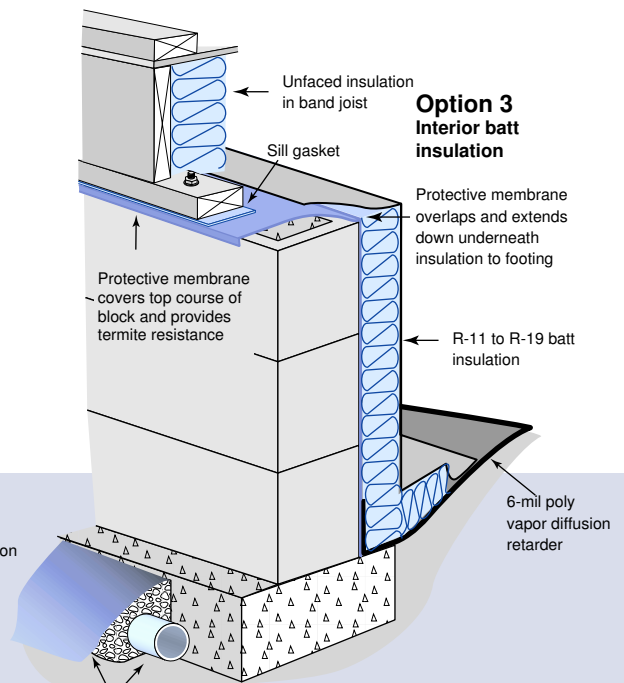

Perforated drainage pipe is embedded in gravel, covered with filter fabric, and located at lower perimeter of foundation footing to provide drainage.

### Option 3 Interior batt insulation

Protective membrane overlaps and extends down underneath insulation to footing  
R-11 to R-19 batt insulation

6-mil poly vapor diffusion retarder

# CRAWLSPACE INSULATION

5. Locate the crawlspace access inside the home or install an access through the perimeter that will remain airtight after repeated use.
6. Select insulation levels in accordance with the International Energy Conservation Code or the DOE Insulation Fact Sheet. The Insulation Fact Sheet (DOE/CE-0180) can be ordered from the Energy Efficiency and Renewable Energy Clearinghouse or accessed from the Internet at [www.ornl.gov/roofs+walls](http://www.ornl.gov/roofs+walls).
7. Install rigid or batt insulation using one of three options (exterior foam, interior foam, or interior batt) to achieve complete insulation coverage. Insulate the band joist with batt insulation, and the crawlspace access if it is located in the wall. Install a continuous termite shield between the band joist and masonry foundation wall that covers the wall insulation and extends completely outside, or leave a 2- to 4-inch insulation gap at the top for termite inspection.
8. Install a supply outlet in the crawlspace, relying on the leakiness of the floor to provide the return air path.

## STEPS FOR INSTALLING UNDERFLOOR INSULATION

1. During the early phases of construction, meet with the mechanical subcontractors (plumbing, electrical, and heating/cooling) to inform them of the importance of keeping the space between floor joists as clear as possible. Run drain lines, electrical wiring, and ductwork below the bottom of the insulation so that a continuous layer of insulation can be installed. For protection against freezing, supply plumbing may be located within the insulation. The best approach is to run supply plumbing together in a few joist spaces. The insulation can be split and run around the piping.
2. Seal all air leaks between the conditioned area of the home and the crawlspace. High-priority leaks include holes around bathtub drains and other drain lines, plenums for ductwork, and penetrations for electrical wiring, plumbing, and ductwork (including duct boot connections at the floor).
3. Select insulation levels in accordance with the International Energy Conservation Code or the DOE Insulation Fact Sheet.
4. Insulation batts with an attached vapor barrier are usually used to insulate framed floors. Obtain insulation with the proper width for the joist spacing of the floor being insulated. Complete coverage is essential – leave no insulation voids. The batts should be installed flush against the subfloor to eliminate any gaps that may serve as passageways for cold air to flow between the insulation and the subfloor. The batts should be cut to the full length of the

## UNDERFLOOR INSULATION

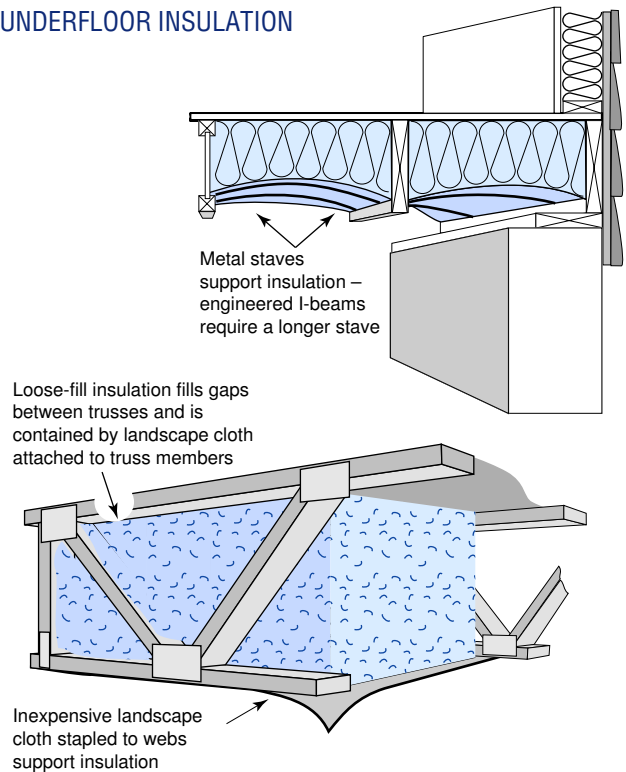

### • INSULATING TRUSS FLOOR SYSTEMS

Instead of batt insulation, a better approach is to install netting or rigid insulation to the underside of the floor trusses and filling the space created between the netting or insulation and subfloor with a loose-fill insulation.

- joist being insulated and slit to fit around wiring and plumbing. Insulate the band joist area between air ducts and the floor as space permits. Use insulation hangers (wire staves) spaced every 12-18 inches to hold the floor insulation in place without compressing the insulation more than 1 inch.
5. The orientation of the vapor barrier depends on the home's location. In most of the country, the vapor barrier should face upward. However, in certain regions of the Gulf states and other areas with mild winters and hot summers, it should face downward.
6. Insulate all ductwork in the crawlspace.
7. Insulate all hot and cold water lines in the crawlspace unless they are located within the insulation.
8. Close crawlspace vents after making sure the crawlspace is dry and all construction materials have dried out.

# CRAWLSPACE INSULATION

For more information, contact:

**Energy Efficiency and Renewable Energy Clearinghouse (EREC)**  
1-800-DOE-3732  
[www.eren.doe.gov](http://www.eren.doe.gov)

Or visit the BTS Web site at  
[www.eren.doe.gov/buildings](http://www.eren.doe.gov/buildings)

Or refer to the Builder's Guide Energy Efficient Building Association, Inc.  
651-268-7585  
[www.eeba.org](http://www.eeba.org)

Written and prepared for the U.S. Department of Energy by:

**Southface Energy Institute**  
404-872-3549  
[www.southface.org](http://www.southface.org)

**U.S. Department of Energy's Oak Ridge National Laboratory**  
Buildings Technology Center  
423-574-5178  
[www.ornl.gov/ORNL/BTC](http://www.ornl.gov/ORNL/BTC)

The International Energy Conservation Code can be obtained from the International Code Council by calling 703-931-4533, [www.intlcode.org](http://www.intlcode.org)

MECcheck, a companion compliance software package, can be ordered from DOE by calling 1-800-270-CODE or downloaded directly from the Web at: [www.energycodes.org/resid/resid.htm](http://www.energycodes.org/resid/resid.htm).

NOTICE: Neither the United States government nor any agency thereof, nor any of their employees, makes any warranty, express or implied, or assumes any legal liability or responsibility for the accuracy, completeness, or usefulness of any information, apparatus, product, or process disclosed. The views and opinions of authors expressed herein do not necessarily state or reflect those of the United States government or any agency thereof.

## ARE CRAWLSPACE VENTS NECESSARY?

Most building codes require crawlspace vents to aid in removing moisture from the crawlspace. However, many building professionals are now recognizing that an unvented crawlspace (or closing crawlspace vents after the crawlspace has had time to dry out after construction) is the best option in homes using proper moisture control and exterior drainage techniques for two reasons.

First, ventilation in the winter is undesirable in order to keep crawlspaces warmer. Second, warm, moist outdoor air brought into the crawlspace through foundation vents in the summer is often unable to dehumidify a crawlspace and, in fact, can lead to increased moisture levels in the crawlspace.

For example, a crawlspace kept cool by the ground in the summer may have a temperature of 65°F and 90% relative humidity (RH)—the dew point temperature of the air is 62°F. The dew point of outdoor air at 90°F and 60% RH is about 74°F. Thus, outdoor air brought into the crawlspace will actually increase the moisture level until water condenses out on cool crawlspace surfaces such as floor joists, foundation walls, and air-conditioning ducts. As framing stays moist, mold grows and dry rot develops.

## PSYCHROMETRIC CHART

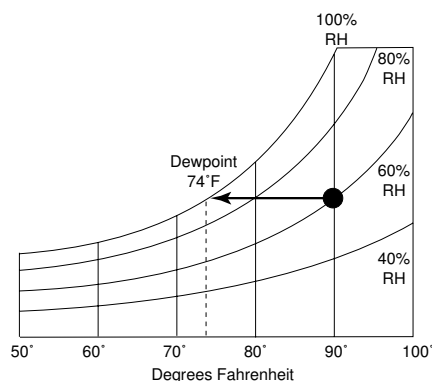

Printed with a renewable-source ink on paper containing at least 50% wastepaper, including 20% postconsumer waste.

December 2000 DOE/G02000-0774

## BUILD IN RADON RESISTANCE

Radon is a radioactive gas that occurs in some soils. It can enter a home through the foundation and floor system. If it occurs in significant concentrations (greater than 4 pico-curies per liter), it may pose a severe health risk to the home occupants. To guard against radon problems:

- Install a sealed, continuous layer of 6-mil polyethylene over the crawlspace floor.
- Install a plastic tee below the polyethylene that protrudes through the polyethylene.
- Install a vertical 3-inch plastic pipe from the foundation to the roof through an interior wall.
- Connect the tee to the vertical 3-inch plastic pipe for passive mitigation.
- Have an electrician stub-in a junction box in the attic.
- Test the bottom conditioned room for radon with an EPA-listed radon test kit, or hire a qualified technician. If the house has a high radon concentration, install an active radon mitigation system by attaching a small blower to the plastic pipe in the attic to expel the gases to the outside.
- If radon levels are especially high (over 25 pico-curies per liter), consult with local radon experts.

## RADON RESISTANT CONSTRUCTION

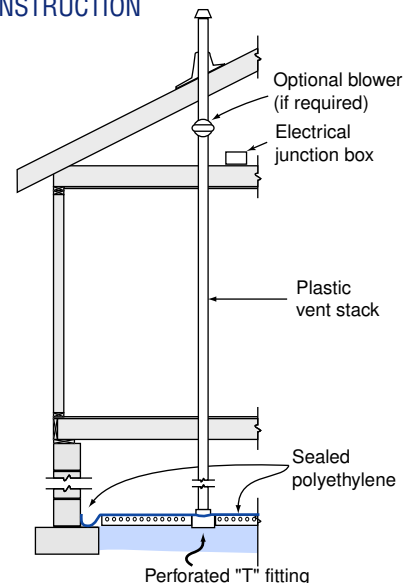

# SLAB INSULATION

*Improve comfort and save energy  
in homes with slab-on-grade floors*



## Buildings for the 21st Century

Buildings that are more energy efficient, comfortable, and affordable...that's the goal of DOE's Office of Building Technology, State and Community Programs (BTS). To accelerate the development and wide application of energy efficiency measures, BTS:

- Conducts R&D on technologies and concepts for energy efficiency, working closely with the building industry and with manufacturers of materials, equipment, and appliances
- Promotes energy/money saving opportunities to both builders and buyers of homes and commercial buildings
- Works with state and local regulatory groups to improve building codes, appliance standards, and guidelines for efficient energy use
- Provides support and grants to states and communities for deployment of energy-efficient technologies and practices



### SLAB-ON-GRADE FLOORS PROVIDE AN INEXPENSIVE AND VERSATILE FOUNDATION

Slab-on-grade floors are often the least expensive foundation system and can expedite the construction process. The foundation consists of a concrete slab poured over at least 4 inches of gravel and a layer of 10-mil polyethylene. Virtually any floor covering works well with a slab, although wood flooring systems may require installation of wooden furring strips prior to attaching the wood flooring material.

Homes use slab-on-grade floors in two ways: either as the bottom floor of a home or as the floor in a daylight basement—where the floor level is about even with outside earth. Areas with mild winters do not require a deep foundation. In these regions, slab-on-grade foundations may prove an ideal choice for flat lots.

Care must be taken in designing a home with a slab foundation to avoid a “squat” appearance. For example, porches are at grade level in houses with a slab foundation, rather than being elevated above the yard. The hard surface of the slab foundation may cause injuries, more frequent breakage of dropped objects, and tired feet unless it is covered with carpeting or other softer floor finishes. Use of slab foundations can also make it more difficult to install wiring, plumbing, and ductwork, so the design of these systems into the construction plans and process is essential.

### BENEFITS OF INSULATING SLAB-ON-GRADE FLOORS

Slabs lose energy primarily as a result of heat conducted outward and through the perimeter of the slab. In most sections of the country, insulating the exterior edge of the slab can reduce winter heating bills by 10 to 20 percent.

### SLAB INSULATION

Provides a thermal break to the perimeter of slab-on-grade foundations.



In climates with mild winters, slab insulation in a typical 1,800 square-foot home would save \$50 to \$60 annually. R-10 slab insulation for an 1,800 square-foot home would typically cost \$300 to \$600 to install. Thus, the insulation would pay for itself in 5 to 10 years.

The investment in slab insulation is also economical when it is part of the mortgage. An insulation cost of \$450 would add about \$38 to the annual mortgage. Since the insulation saves over \$50 per year on energy bills, savings exceed the extra mortgage costs and the investment in slab insulation pays off from the beginning.

Slab insulation is important not only to save on energy bills, but also to improve comfort. Cold concrete slabs are one of the most notorious sources of discomfort in a home. Installing slab insulation around the perimeter of the slab will reduce heat loss and make the slab easier to heat. An insulated slab also provides thermal mass to store heat and moderates indoor temperatures.

## SLAB INSULATION TECHNIQUES

Slab insulation can be installed following one of two basic techniques: installing rigid insulation directly against the exterior of the slab and footing or building a “contained” or “floating” slab with interior insulation. Whichever design is followed, the keys to an effective slab foundation are:

**Moisture control**—using a water-managed foundation system to drain rainwater and groundwater away from the foundation.

**Airtight construction**—sealing interfaces between the slab foundation and the exterior wall to reduce infiltration into the house.

**Complete insulation coverage**—properly installing the correct insulation levels and making sure the insulation coverage is continuous and complete.

### PERIMETER INSULATION— SLAB-ON-GRADE CONSTRUCTION

Provide good drainage away from the foundation and capillary breaks for a durable foundation. Perimeter insulation increases comfort in the living space.

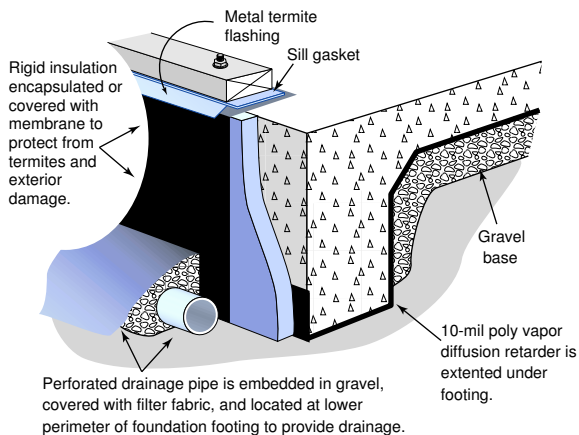

### FLOATING SLAB-ON-GRADE CONSTRUCTION

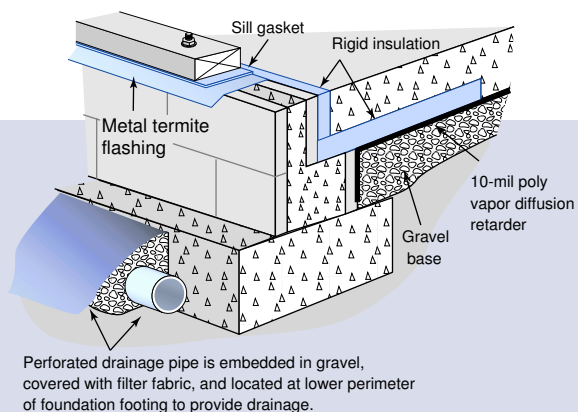

## MOISTURE AND AIR LEAKAGE CONTROL

1. Keep all untreated wood materials away from the earth.
2. Install well-designed guttering and downspouts that are connected to a drainage system diverting rainwater completely away from the house.
3. Slope the earth away from the house for at least 5 feet at a minimum 5% grade (3 inches in 5 feet). Establish drainage swales as needed to direct rainwater around the house.
4. Add a sill gasket membrane between the slab and bottom plate to provide air sealing.
5. Install a protective membrane (such as rubberized roofing material or ice-dam protection membranes) to serve as a capillary break that reduces wicking of water up from the foundation. This membrane can also serve as a termite shield.
6. Install a foundation drain directly beside the bottom of the footing. The foundation drain assembly includes a filter fabric, gravel, and a perforated plastic drain pipe typically 4 inches in diameter. Locate the drain beside the footing, not on top, to avoid water flowing against the seam between the footing and the foundation wall and prevent wicking from a web footing through the stem wall.
7. Install a capillary break and moisture barrier under the slab floor, consisting of a layer of 10-mil polyethylene placed over at least 4 inches of gravel.

## INSULATION

1. Review the plan for slab insulation with pest control and local building officials to ensure code compliance.
2. Select insulation levels in accordance with the International Energy Conservation Code (IECC) or DOE Insulation Fact Sheet. The Insulation Fact Sheet (DOE/CE-0180) can be ordered from the Energy Efficiency and Renewable Energy Clearinghouse or accessed from the Internet at [www.ornl.gov/roofs+walls](http://www.ornl.gov/roofs+walls).
3. Install rigid insulation using one of the two general designs shown to achieve complete insulation coverage of the slab perimeter. Use only insulation approved for below-grade use.

# SLAB INSULATION

## R-VALUES AND RECOMMENDED DEPTH FOR SLAB INSULATION

The IECC specifies both the R-value of the slab insulation and the minimum distance for the insulation from the top of the slab downward based on a locality's Heating Degree Days (HDDs):

Heating Degree Days	Feet Installed Vertically	R-value of Slab Insulation
0 to 2,499	none required	
2,499 to 4,500	2 feet	R-4
4,500 to 6,000	2 feet	R-5
6,000 to 7,200	4 feet	R-6
7,200 to 8,700	4 feet	R-7
8,700 to 10,000	4 feet	R-8
10,000 to 12,400	4 feet	R-9
12,400 to 14,000	4 feet	R-10

### HDD=HEATING DEGREE DAYS

(Consult your local weather bureau for your city's actual annual Heating Degree Days.) Heating Degree Days is a term used to help indicate the heating needed for any certain day. This method is commonly used to determine fuel consumption and/or the cost of heating during a season by using historical weather trends to calculate average seasonal temperatures.

#### 4. If insulation is installed on the exterior of the slab:

- The insulation should be installed from the top of the slab to the bottom of the frost line unless a termite inspection gap is required.
- Encapsulate or cover the exterior face of the insulation with a protective membrane to serve as a capillary break and to protect the insulation from termites.
- Cover the above-grade portion of the insulation exposed to outside air using a stucco coating, pressure-treated wood, brick, or aluminum flashing. When covering insulation, be conscious of how to detect termites in areas prone to termite infestation. Some states in termite-prone areas have addressed this issue by requiring a termite inspection gap near the top of the slab insulation.

## BUILD IN RADON RESISTANCE WHEN INSTALLING SLAB-ON-GRADE FOUNDATIONS

Radon is a radioactive gas that occurs in some soils. It can enter a home through the foundation and floor system. If it occurs in significant concentrations (greater than 4 pico-curies per liter), it may pose a severe health risk to the home occupants. To guard against radon problems in concrete slabs:

- Use a 4- to 6-inch gravel base and a continuous layer of 10-mil polyethylene on top of the gravel.
- Install a tee below the polyethylene that protrudes through the polyethylene and extends above the poured floor height.
- Connect the tee to a 3-inch vertical plastic pipe that extends to the roof through an interior wall.
- Pour the slab and seal all slab joints with caulk.
- Have an electrician stub-in a junction box in the attic.
- Test the bottom-most conditioned room for radon with an EPA-listed radon test kit, or hire a qualified technician. If the house has a high radon concentration, install an active radon mitigation system by attaching a small blower to the plastic pipe in the attic to expel the gasses to the outside.
- If radon levels are especially high (over 25 pico-curies per liter), consult with local radon experts.

## RADON-RESISTANT CONSTRUCTION

Passive radon-resistant construction is an inexpensive first cost. It can easily be upgraded if active mitigation is later required to cure a radon problem.

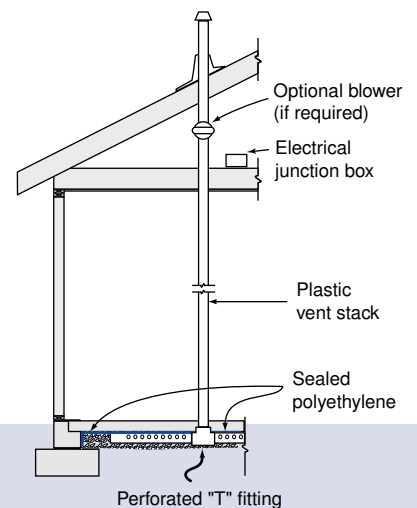



# SLAB INSULATION

For more information, contact:

**Energy Efficiency and Renewable Energy Clearinghouse (EREC)**  
1-800-DOE-3732  
[www.eren.doe.gov](http://www.eren.doe.gov)

Or visit the BTS Web site at  
[www.eren.doe.gov/buildings](http://www.eren.doe.gov/buildings)

Or refer to the Builder's Guide Energy Efficient Building Association, Inc.  
651-268-7585  
[www.eeba.org](http://www.eeba.org)

Written and prepared for the U.S. Department of Energy by:

**Southface Energy Institute**  
404-872-3549  
[www.southface.org](http://www.southface.org)

**U.S. Department of Energy's Oak Ridge National Laboratory**  
Buildings Technology Center  
423-574-5178  
[www.ornl.gov/ORNL/BTC](http://www.ornl.gov/ORNL/BTC)

The International Energy Conservation Code can be obtained from the International Code Council by calling 703-931-4533  
[www.intlcode.org](http://www.intlcode.org)

MECcheck, a companion compliance software package, can be ordered from DOE by calling 1-800-270-CODE or from the Web at [www.energycodes.org/resid/resid.htm](http://www.energycodes.org/resid/resid.htm).

*NOTICE: Neither the United States government nor any agency thereof, nor any of their employees, makes any warranty, express or implied, or assumes any legal liability or responsibility for the accuracy, completeness, or usefulness of any information, apparatus, product, or process disclosed. The views and opinions of authors expressed herein do not necessarily state or reflect those of the United States government or any agency thereof.*

## SPECIAL REQUIREMENTS OF SLAB INSULATION FOR TERMITE CONTROL

Over the past decade, reports of termite infestations in homes with exterior slab insulation have become more frequent. These pests tunnel undetected through the insulation to gain access to the wood framing in the walls. Some insurance companies no longer guarantee homes with slab insulation against termite damage. Recent rulings by national code organizations, such as the International Code Council, prohibit installing foam insulation in contact with the ground in several southern states (South Carolina, Florida, Georgia, Alabama, Mississippi, Louisiana, Arkansas, and Texas).

An alternative to slab edge insulation is to create a contained or floating slab with interior foam insulation. This non-monolithic approach provides termite resistance because the insulation is sealed within the slab. However, builders in the Southeast United States recently reported termite infestations through foam insulation on contained slabs.

Termite prevention is a key goal when installing slab insulation, especially where a visual inspection of the foundation is not possible. The key to controlling termites is proper treatment, a regular inspection policy, and a strong warranty from a termite company. Before construction, confer with a pest control company to ensure a favorable termite contract.

## ✓ FOLLOW THESE GUIDELINES TO OFFSET TERMITE PROBLEMS:

- Provide effective moisture control systems.
- Remove all wood from around the foundation before backfilling.
- Install termite shields continuously under the sill plate of the building. While not 100 percent effective, the termite shield may deter or delay widespread infestation and may also force termites into an exposed area where they can be detected. It should project beyond the sill plate and all other portions of the exterior wall. A continuous layer of a membrane such as rubberized roofing material used in commercial buildings may be used as an alternative to the termite shield.
- Use a foam insulation with a termiticide. Usually a derivative of boric acid, the termiticide should pose no more threat to home owners than traditional termite treatments. One of the nation's leading foam insulation manufacturers is planning to offer a termite-treated insulation board on the market in the year 2000 or 2001.



Printed with a renewable-source ink on paper containing at least 50% wastepaper, including 20% postconsumer waste.

December 2000 DOE/G0102000-0775



### Buildings for the 21st Century

Buildings that are more energy-efficient, comfortable, and affordable...that's the goal of DOE's Office of Building Technology, State and Community Programs (BTS). To accelerate the development and wide application of energy efficiency measures, BTS:

- Conducts R&D on technologies and concepts for energy efficiency, working closely with the building industry and with manufacturers of materials, equipment, and appliances
- Promotes energy/money saving opportunities to both builders and buyers of homes and commercial buildings
- Works with State and local regulatory groups to improve building codes, appliance standards, and guidelines for efficient energy use
- Provides support and grants to States and communities for deployment of energy-efficient technologies and practices



# AIR SEALING

*Seal air leaks and save energy!*

### WHAT IS AIR LEAKAGE?

Ventilation is fresh air that enters a house in a controlled manner to exhaust excess moisture and reduce odors and stuffiness. Air leakage, or *infiltration*, is outside air that enters a house uncontrollably through cracks and openings. It is unwise to rely on air leakage for ventilation. During cold or windy weather, too much air may enter the house and, during warm or calm weather, too little. Also, a leaky house that allows moldy, dusty crawlspace or attic air to enter is not healthy.

The recommended strategy in both new and old homes is to reduce air leakage as much as possible and to provide controlled ventilation as needed. For simple house designs, effective spot ventilation, such as kitchen and bath fans that exhaust to the outside, may be adequate. For more complex houses or ones in colder climates, whole house ventilation systems may be appropriate. Such systems may incorporate heat recovery, moisture control, or air filtering.

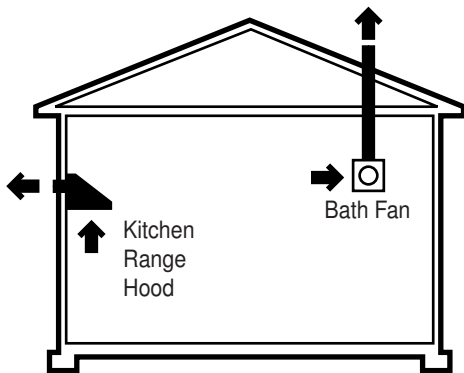

Kitchen and bath vents provide spot ventilation

### WHAT ARE THE BENEFITS OF AIR SEALING?

Air infiltration can account for 30 percent or more of a home's heating and cooling costs and contribute to problems with moisture,

noise, dust, and the entry of pollutants, insects, and rodents. Reducing infiltration can significantly cut annual heating and cooling costs, improve building durability, and create a healthier indoor environment. The size of heating and cooling equipment can also be decreased, which saves additional dollars. Reducing air leakage in new homes, as required by the 1995 Model Energy Code (see page 4), typically costs less than \$200 for the average home and does not require specialized labor.

Annual Energy Costs for 1300 sq. ft. house			
	Infiltration rate		Savings
Atlanta	High*	Low**	
Heating	\$311	\$244	\$67
Cooling	\$196	\$178	\$18

\* Estimated 12 air changes per hour at 50 Pascal pressure difference  
 \*\* Estimated 6 air changes per hour at 50 Pascal pressure difference

### WHAT IS AN AIR BARRIER?

The ceilings, walls, and floor/foundation that separate the inside conditioned space from the outside or unconditioned space form the air barrier and the insulation barrier for a house. These two barriers differ by the materials used.

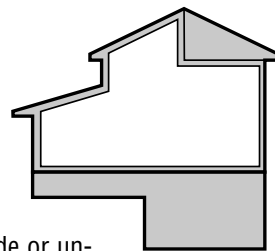

For most homes, the sheet goods that form the ceilings, walls, and floor (such as drywall, sheathing, and decking) are effective at stopping air leakage. It is critical to seal all holes and seams between these sheet goods with durable caulks, gaskets, and foam sealants to create a *continuous* air barrier. The insulation barrier is usually made up of standard insulating materials, such as batt or loose fill products, that do not seal against air leakage.

## WHAT ARE THE PRIORITIES FOR AIR SEALING?

Although windows, doors, and outside walls contribute to air leakage, the biggest holes are usually hidden from view and connect the house to the attic, crawlspace, or basement. The key is to identify these areas during the design process, assign responsibility for sealing holes, and check to ensure that the air sealing was done effectively. Usually, seal all the big holes first, then the large cracks and penetrations, and finally the smaller cracks and seams.

## WHERE ARE THESE LEAKAGE SITES?

Dropped ceilings and kitchen soffits, ductwork and plumbing chases, attic accesses and pull-down stairs, recessed light fixtures, holes in mechanical room closets, and wiring penetrations through the top plates of walls represent major connections between the attic and conditioned space. Many times unseen holes or pathways, called bypasses, occur at key junctures in the framing (such as at attic-to-kneewall transitions) and permit large quantities of air to leak in and out of the home.

Major leakage sites in the floor can be found around the tub drain and the numerous plumbing, HVAC, and wiring penetrations through the floor decking and bottom plates of walls. In walls, the band joist (for two-story homes), window and door rough openings, and penetrations through the drywall and exterior sheathing are primary leakage sites.

### ✓ AIR SEALING MATERIALS

*Use a combination of these different air sealing materials.*

- **Caulk:** Seals gaps of less than ½". Select grade (interior, exterior, high temperature) based on application.

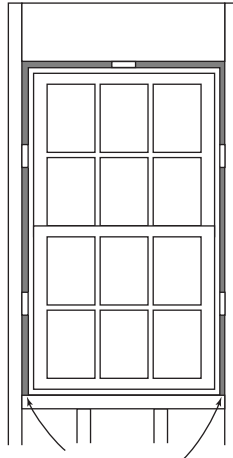

Use backer rod to fill gaps between window and rough opening before caulking or use non-expanding foam.

- **Spray foam:** Fills large cracks and small holes. It can be messy; consider new latex-based foams. DO NOT USE near flammable applications (e.g., flue vents). DO NOT USE expanding types on windows and doors.
- **Backer rod:** Closed-cell foam or rope caulk. Press into crack or gap with screwdriver or putty knife. Often used with caulk around window and door rough openings.
- **Gaskets:** Apply under the bottom plate before an exterior wall is raised or use to seal drywall to framing instead of caulk or adhesive.
- **Housewrap:** Installed over exterior sheathing. Must be sealed with housewrap tape or caulk to form an airtight seal. Resists water but is *not* a vapor barrier.
- **Sheet goods** (plywood, drywall, rigid foam insulation): These materials form the air barrier. Air leaks only at unsealed seams or penetrations.
- **Sheet metal:** Used with high-temperature caulk for sealing high-temperature components, such as flues and chimneys, to framing.
- **Polyethylene plastic:** This inexpensive material for air sealing also stops vapor diffusion. All edges and penetrations must be completely sealed for an effective air barrier. Poly is fragile, and proper placement is climate specific.
- **Weatherstripping:** Used to seal moveable components, such as doors, windows, and attic accesses.
- **Mastic:** Seals air handlers and all duct connections and joints.
- **UL181 or foil-faced tape:** Temporarily seals the air handler.

## DIAGNOSTIC TOOLS

Testing the airtightness of a home using a special fan called a blower door can help to ensure that air sealing work is effective. Often, energy efficiency incentive programs, such as the DOE/EPA ENERGY STAR Program, require a blower door test (usually performed in less than an hour) to confirm the tightness of the house.

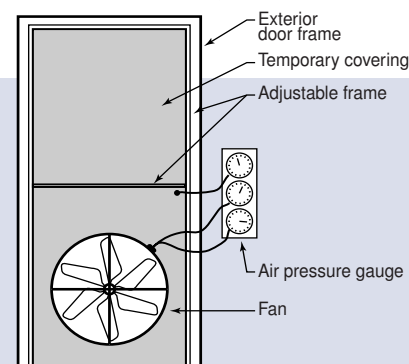

### DON'T RELY ON THE INSULATION:

The most common insulation, fiberglass, does *not* stop air leakage. In older homes, dirty fiberglass is a telltale sign of air movement (it simply collects dirt like a filter). Certain types of insulation, such as dense-packed cellulose and certain foams, can be effective at reducing air flow as well as heat flow.

# AIR SEALING

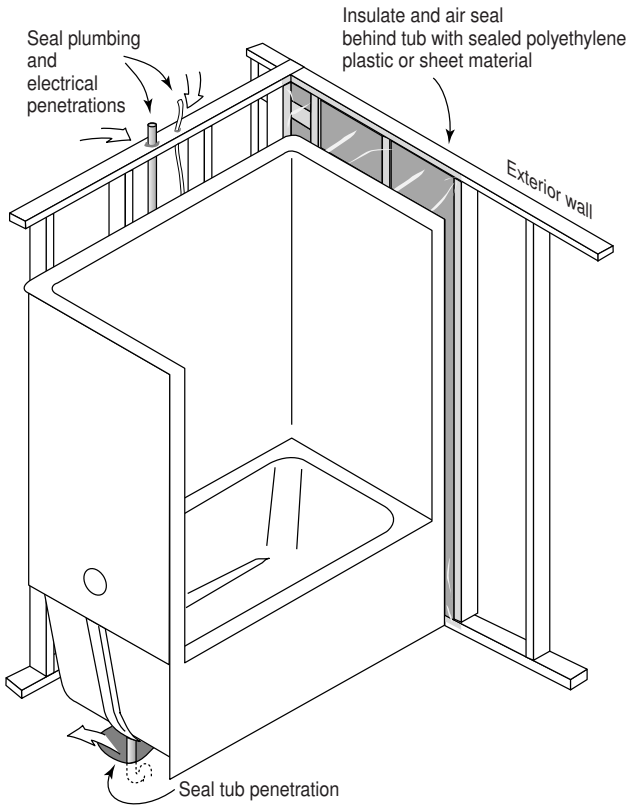

Seal and insulate exterior wall before installing bath tubs.

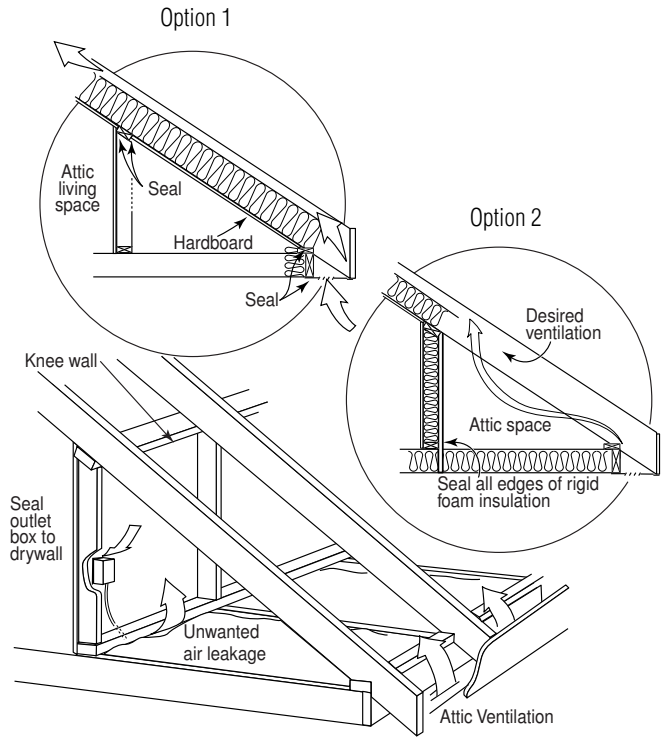

Seal kneewall to create a continuous air barrier.

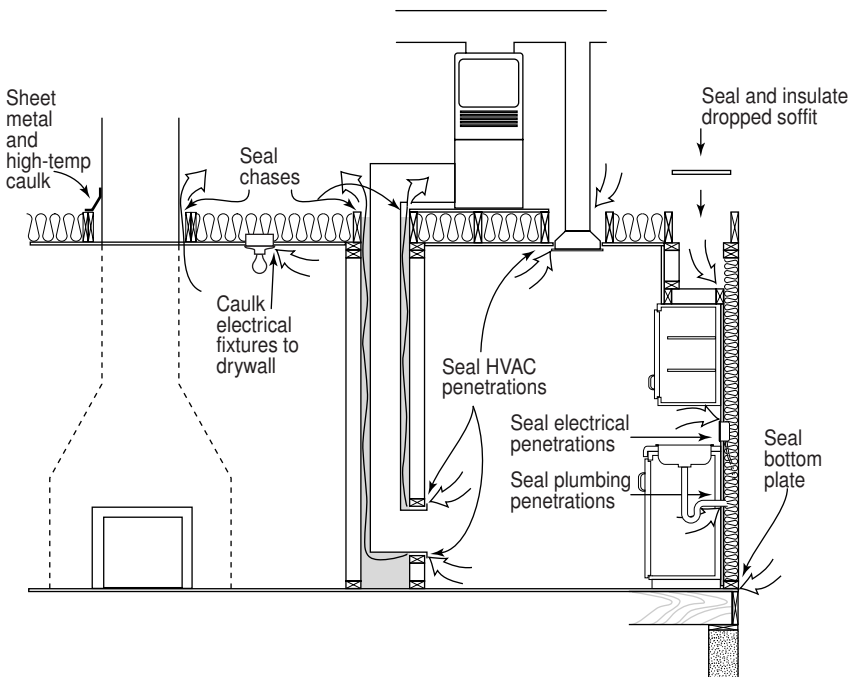

Seal dropped soffit ceilings, plumbing and electrical penetrations, and utility chases.

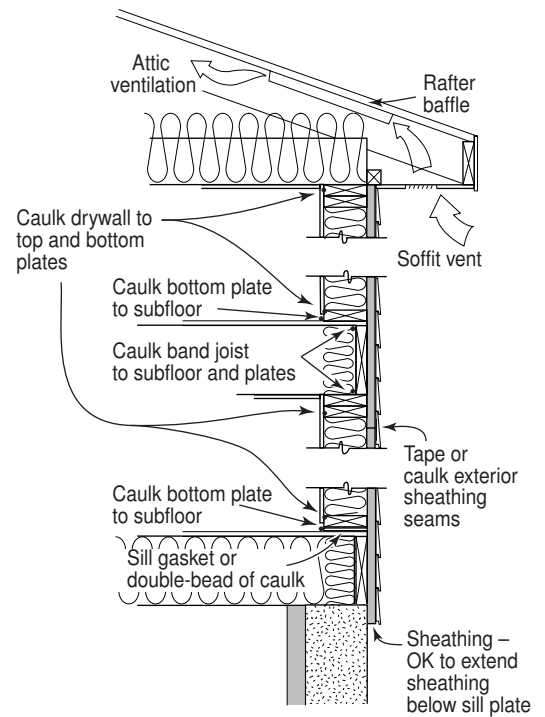

Seal exterior sheathing joints, and top and bottom plates.

# AIR SEALING

For more information, contact:

**Energy Efficiency and  
Renewable Energy  
Clearinghouse (EREC)**  
1-800-DOE-3732  
[www.eren.doe.gov](http://www.eren.doe.gov)

Or visit the BTS Web site at  
[www.eren.doe.gov/buildings](http://www.eren.doe.gov/buildings)

Or refer to the Builder's Guide  
Energy Efficient Building  
Association, Inc.  
651-268-7585  
[www.eeba.org](http://www.eeba.org)

Written and prepared for  
the U.S. Department of  
Energy by:

**Southface Energy Institute**  
404-872-3549  
[www.southface.org](http://www.southface.org)

**Oak Ridge  
National Laboratory**  
Buildings Technology Center  
423-574-5178  
[www.ornl.gov/ornl/btc](http://www.ornl.gov/ornl/btc)

The Model Energy Code  
can be obtained from the  
International Code Council by  
calling 703-931-4533

MECcheck, a companion  
compliance software  
package, can be ordered from  
DOE by calling  
1-800-270-CODE  
or downloaded directly  
from the Web at  
[www.energycodes.org/  
resid/resid.htm](http://www.energycodes.org/resid/resid.htm).

*NOTICE: Neither the United States gov-  
ernment nor any agency thereof, nor  
any of their employees, makes any war-  
ranty, express or implied, or assumes  
any legal liability or responsibility for the  
accuracy, completeness,  
or usefulness of any information, appa-  
ratus, product, or process disclosed.  
The views and opinions of authors ex-  
pressed herein do not necessarily state  
or reflect those of the United States  
government or any agency thereof.*

## AIR SEALING CHECKLIST

### ✓ BEFORE DRYWALL

- Seal bottom plate of exterior walls with caulk or gasket; seal inside edge with caulk after walls are up.
- Seal band joist with caulk, spray foam, or gasketing between top plate and band joist, and between band joist and subfloor.
- For bath tubs on outside walls, insulate the exterior wall and air seal behind tub with sheet goods or plastic before tub is installed. After the drain is installed, seal the tub drain penetration with sheet goods and caulk or spray foam.
- For dropped ceilings or soffits, duct and flue chases, and open partition walls, use sheet goods and sealant to stop air leakage from attic into soffit and then insulate. Alternately, install framing and drywall for the soffits *after* the taped ceiling drywall is installed.
- Caulk the backsides of window flanges to the sheathing during installation.
- Seal between door thresholds and subflooring with caulk.
- Seal window and exterior door rough openings with backer rod and caulk, or use non-expanding latex-based spray foams that will not pinch jambs or void window warranties.
- Seal all electrical wire, plumbing, and HVAC penetrations between any conditioned and unconditioned spaces with caulk or spray foam.
- Seal wiring and knockouts in electrical boxes with caulk. Also seal outdoor-mounted boxes to the exterior sheathing.

### ✓ DURING DRYWALL

- Seal drywall to top and bottom plates using gaskets, adhesive, or caulk.

### ✓ AFTER DRYWALL

- Seal electrical switch, outlet, and circuit breaker boxes to drywall with caulk or foam.
- Seal light fixture boxes, medicine cabinets, and bath and kitchen ventilation fans to drywall with caulk or foam.
- Seal all duct boots to floor or drywall with caulk, foam, or mastic.
- Seal any plumbing or electrical wire penetration through drywall with caulk or foam.
- Seal gaps at whole house fan with spray foam or housewrap tape (ensure louvers function properly).
- For attic hatches and kneewall access doors, weatherstrip and include a tight latch. Add rigid insulation.
- For attic pull-down stairs, make stairs airtight using latch bolts and weatherstripping. Add an insulated cover.
- Seal between a masonry chimney and the attic framing using sheet metal or other noncombustible sheet goods and high-temperature (450°F), fire-rated caulk.
- Seal around the metal flue of combustion equipment using a UL-approved metal collar and high-temperature (450°F), fire-rated caulk.
- Use only UL-approved airtight, IC-rated recessed light fixtures (that meet ASTM E283 requirements); seal between fixture and drywall with caulk.

### ✓ AIR SEAL EXTERIOR

- Repair any damaged sheathing pieces.
- Seal all exterior penetrations, such as porch light fixtures, phone, security, cable and electric service holes, with caulk or spray foam.
- If not using housewrap, seal all sheathing seams with housewrap tape or caulk.



Printed with a renewable-source ink on paper containing at least 50% wastepaper, including 20% postconsumer waste.  
November 1999 DOE/G010099-767

# WHOLE-HOUSE VENTILATION SYSTEMS

*Improved control of air quality*



## Buildings for the 21st Century

Buildings that are more energy efficient, comfortable, and affordable...that's the goal of DOE's Building Technologies Program.

To accelerate the development and wide application of energy efficiency measures, the Building Technologies Program:

- Conducts R&D on technologies and concepts for energy efficiency, working closely with the building industry and with manufacturers of materials, equipment, and appliances
- Promotes energy/money saving opportunities to both builders and buyers of homes and commercial buildings
- Works with state and local regulatory groups to improve building codes, appliance standards, and guidelines for efficient energy use

### PURPOSE OF VENTILATION

All homes need ventilation—the exchange of indoor air with outdoor air—to reduce indoor moisture, odors, and other pollutants.

Contaminants such as formaldehyde, volatile organic compounds (VOCs), and radon that may cause health problems can accumulate in poorly ventilated homes. Inadequate ventilation allows unpleasant odors to linger. Excess moisture generated within the home needs to be removed before high humidity levels lead to physical damage to the home or mold growth.

### VENTILATION STRATEGIES

To ensure adequate ventilation, the American Society of Heating, Refrigerating and Air-Conditioning Engineers, Inc. (ASHRAE) says that the living area of a home should be ventilated at a rate of 0.35 air changes per hour or 15 cubic feet per minute (cfm) per person, whichever is greater.

*Natural ventilation*—uncontrolled air movement into a building through cracks and small holes (infiltration) and through vents such as windows and doors—is the traditional method of allowing fresh outdoor air to replace indoor air. Nowadays, because of central heating and cooling, as well as the desire for privacy, people tend to make little use of windows for ventilation, so infiltration has become the principal mode of natural ventilation in homes. Unfortunately, a home's natural infiltration rate is unpredictable and uncontrollable because it depends on the home's airtightness, outdoor temperatures, wind, and other factors. During mild weather, some homes may lack sufficient ventilation for pollutant removal. Tightly built homes may

have insufficient ventilation at most times.

Homes with high infiltration rates may experience high energy costs. Also, infiltration may allow contaminated air to enter from a polluted area such as a garage or crawlspace, or may not ventilate the house uniformly.

*Whole-house ventilation*—use of one or more fans and duct systems to exhaust stale air and/or supply fresh air to the house—can better control the exchange of indoor air with outdoor air. Energy experts often quote the axiom, “seal tight, ventilate right” as their recommended approach to house ventilation.

This axiom implies that houses should be tightly sealed to reduce infiltration, and a whole-house ventilation system installed to provide fresh air and remove pollutants when and where needed, in a controlled manner (i.e., in amounts needed) that does not negatively impact indoor air quality, building components, or heating and cooling bills.

*Spot ventilation*—the use of localized exhaust fans (e.g., kitchen range and bath fans) to quickly remove pollutants at their source—is an important tool to improve air quality whether natural or whole-house ventilation strategies are used. Spot ventilation improves the effectiveness of ventilation systems by removing pollutants at their source as they are generated and should be an integral part of any whole-house ventilation design. In addition to its whole-house ventilation requirement, ASHRAE recommends intermittent or continuous ventilation rates for bathrooms and kitchens as alternatives to operable windows: 50 or 20 cfm for bathrooms and 100 or 25 cfm for kitchens, respectively.



## WHOLE-HOUSE VENTILATION SYSTEM DESIGNS

The decision to use whole-house ventilation is typically motivated by concern that natural ventilation is not providing adequate air quality, even with source control by spot ventilation. Whole-house ventilation systems are usually classified as *exhaust ventilation* if the mechanical system forces inside air out of the home, *supply ventilation* if the mechanical system forces outside air into the home, or *balanced ventilation* if the mechanical system forces equal quantities of air into and out of the home.

### ✓ EXHAUST VENTILATION SYSTEMS

Exhaust ventilation systems work by depressurizing the building. By reducing the inside air pressure below the outdoor air pressure, they extract indoor air from a house while make-up air infiltrates through leaks in the building shell and through intentional, passive vents.

Exhaust ventilation systems are relatively simple and inexpensive to install. Typically, an exhaust ventilation system is composed of a single fan connected to a centrally located, single exhaust point in the house. A preferable design option is to connect the fan to ducts from several rooms (preferably rooms where pollutants tend to be generated, such as bathrooms). Adjustable, passive vents through windows or walls can be installed in other rooms to introduce fresh air

rather than rely on leaks in the building envelope. However, their use may be ineffective because larger pressure differences than those induced by the ventilation fan may be needed for them to work properly. Spot ventilation exhaust fans installed in the bathroom but operated continuously can represent an exhaust ventilation system in its simplest form.

Exhaust ventilation systems are most applicable in cold climates. In climates with warm humid summers, depressurization can draw moist air into building wall cavities, where it may condense and cause moisture damage.

One concern with exhaust ventilation systems is that they may draw pollutants, along with fresh air, into the house. For example, in addition to drawing in fresh outdoor air, they may draw in radon and molds from a crawlspace, dust from an attic, fumes from an attached garage, or flue gases from a fireplace or fossil-fuel-fired water heater and furnace. This can especially be of concern when bath fans, range fans, and clothes dryers (which also depressurize the home while they operate) are run when an exhaust ventilation system is also operating. Also, exhaust ventilation systems can contribute to higher heating and cooling costs compared with heat-recovery systems because exhaust systems do not temper or remove moisture from the make-up air before it enters the house.

### CENTRAL VENTILATION STRATEGIES

- ← Air flow
- ⊞ Air infiltration
- ⊕ Positive air pressure
- ⊖ Negative air pressure

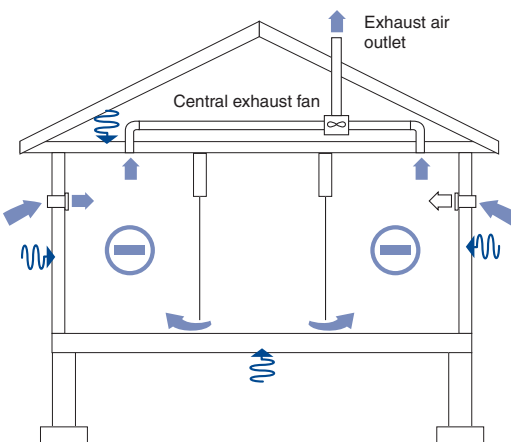

Exhaust ventilation

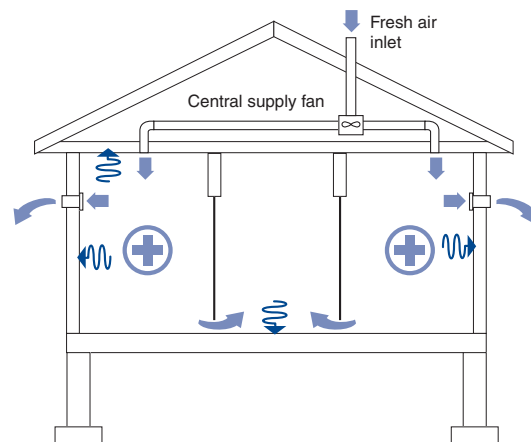

Supply ventilation

### ✓ SUPPLY VENTILATION SYSTEMS

Supply ventilation systems work by pressurizing the building. They use a fan to force outside air into the building while air leaks out of the building through holes in the shell, bath and range fan ducts, and intentional vents (if any exist).

As with exhaust ventilation systems, supply ventilation systems are relatively simple and inexpensive to install. A typical supply ventilation system has a fan and duct system that introduces fresh air into usually one, but preferably several rooms of the home that residents occupy most often (e.g., bedrooms, living room), perhaps with adjustable window or wall vents in other rooms. Supply ventilation systems allow better control of the air that enters the house than do exhaust ventilation systems. By pressurizing the house, supply ventilation systems discourage the entry of pollutants from outside the living space and avoid backdrafting of combustion gases from fireplaces and appliances. Supply ventilation also allows outdoor air introduced into the house to be filtered to remove pollen and dust or dehumidified to provide humidity control.

Supply ventilation systems are most applicable in hot or mixed climates. Because they pressurize the house, supply ventilation systems have the potential to cause moisture problems in cold climates. In winter, the supply ventilation system causes warm interior air to leak through random openings in the exterior

wall and ceiling. If the interior air is humid enough, some moisture may condense in the attic or cold outer parts of the exterior wall where it can promote mold, mildew, and decay.

Like exhaust ventilation systems, supply ventilation systems do not temper or remove moisture from the make-up air before it enters the house. Thus, they may contribute to higher heating and cooling costs compared with heat-recovery systems. Because air is introduced in the house at discrete locations, outdoor air may need to be mixed with indoor air before delivery to avoid cold air drafts in the winter. An in-line duct heater is another option, but it will increase operating costs.

### ✓ BALANCED VENTILATION SYSTEMS

Balanced ventilation systems neither pressurize nor depressurize a house if properly designed and installed. Rather, they introduce and exhaust approximately equal quantities of fresh outside air and polluted inside air, respectively. Balanced ventilation systems are appropriate for all climates.

A balanced ventilation system usually has two fans and two duct systems and facilitates good distribution of fresh air by placing supply and exhaust vents in appropriate places. Fresh air supply and exhaust vents can be installed in every room, but a typical balanced ventilation system is designed to supply fresh air to bedrooms and living rooms where people spend

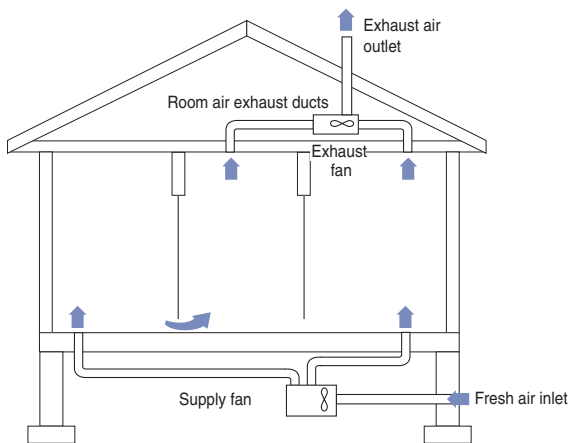

Balanced ventilation

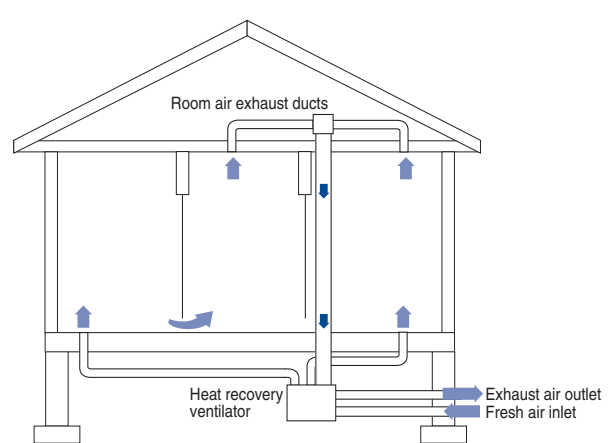

Balanced heat-recovery ventilation



# WHOLE-HOUSE VENTILATION SYSTEMS

the most time, and exhaust air from rooms where moisture and pollutants are most often generated (kitchen, bathrooms, and perhaps the laundry room). Some designs may use a single-point exhaust. Because they directly supply outside air, balanced systems allow the use of filters to remove dust and pollen from outside air before introducing it into the house.

Balanced systems are usually more expensive to install and operate than supply or exhaust systems because they require two duct and fan systems. Like these other systems, balanced ventilation systems do not temper or remove moisture from the make-up air before it enters the house and thus may contribute to higher heating and cooling costs compared with heat-recovery systems. Like supply ventilation systems, outdoor air may need to be mixed with indoor air before delivery to avoid cold air drafts in the winter.

## ✓ **BALANCED, HEAT-RECOVERY VENTILATION SYSTEMS**

A special type of balanced ventilation system adds a heat-recovery unit to the basic design. A heat-recovery unit reduces the heating and cooling costs of ventilation by transferring heat from the warm inside air being exhausted to the fresh but cold outside air in the winter, and vice-versa in the summer. Comfort is also improved because the supply air is tempered before delivery, reducing drafts. Some heat-recovery systems also transfer moisture—an advantage in warm, humid climates in the summer and cold climates in the winter.

Balanced ventilation systems with heat recovery are more costly to install than balanced systems without heat recovery because heat-recovery systems require more powerful fans that use more energy to overcome the air resistance of the heat exchanger.

Balanced, heat-recovery units are most cost effective in climates with extreme winters or summers, and where fuel costs are high. In mild climates, the cost of the additional electricity consumed by the fans may exceed the energy savings from not having to heat and cool the air introduced by the ventilation system.

Heat-recovery systems require more maintenance than other whole-house ventilation systems. They need to be cleaned regularly to prevent deterioration of ventilation rates and heat recovery, and to prevent growth of mold and bacteria on heat exchange surfaces. When warm, moist air is cooled, condensate forms on cool surfaces and must be drained from the heat-recovery system. In cold climates, very cold air

brought into a heat-recovery system can cause frost formation in the heat exchanger. Because frost buildup reduces ventilation effectiveness and can damage the heat exchanger, heat-recovery systems must have devices to deal with frost.

## **INTEGRATION WITH FORCED-AIR HEATING AND AIR CONDITIONING SYSTEMS**

Integrating whole-house ventilation systems into heating and air conditioning systems can reduce the installation cost of the ventilation system by making use of existing fans and ducts to distribute fresh outdoor air throughout the house. Another advantage of some integrated designs is that fresh air can be effectively mixed with indoor air to alleviate drafts.

Most approaches are supply ventilation designs that introduce ventilation air into the return side of the forced-air duct system, although some introduce air into the supply side. To be most effective, heating and cooling ductwork must be airtight or located within the conditioned space of the house.

Several design issues must be addressed, the solutions to which often come at the cost of increased system complexity.

- Ventilation systems that use the air-handler fan tend to provide the most mechanical ventilation in the winter, when the cost of tempering outside air is highest and it is least needed because natural ventilation is usually greatest.
- Ventilation systems that use the air handler fan also tend to provide the least mechanical ventilation when it is most needed. On mild days, the heating and cooling system may not operate when the amount of natural infiltration is minimal. To compensate for this, a controller can be used to turn the air-handler fan on for a short period of time during each hour that the air-handler fan does not operate for heating or cooling.
- Running a large air-handler fan can be noisy and expensive. One solution is to use a more expensive variable-speed air-handler fan that operates at a low speed when heating or cooling is not needed. This approach may require a motorized damper to keep the ventilation rate nearly constant when the fan operates at different speeds. Another solution is to use a smaller, separate fan to pull outdoor air into the ductwork and distribute it throughout the house.
- Duct systems that distribute heated and cooled air effectively when the air flow rate is 800 cfm or more may distribute it poorly when the flow rate is dropped to 100 cfm or less.

# WHOLE-HOUSE VENTILATION SYSTEMS

## CONTROLS

Ventilation experts usually recommend that whole-house ventilation systems be designed to operate automatically so that fresh air is supplied to the house without occupant intervention. An on-off control may also be required by codes.

### ✓ CONTINUOUS CONTROL

Some experts recommend continuous ventilation to simplify controls and to avoid unhealthy indoor air for the several hours it may take a system to flush out pollutants after having been off for an extended time. If pollutants continuously released from furnishings or building materials are the principal concern, continuous ventilation is most effective.

### ✓ PROGRAMMABLE TIMER

Rather than operate a whole-house ventilation system continuously, a programmable timer can be employed to operate the system intermittently for a selected period of time each day. To provide equivalent ventilation, such a system must have a higher capacity than one that operates continuously.

### ✓ OCCUPANCY CONTROL

Some experts recommend that whole-house ventilation systems be controlled to provide fresh air only when occupants are home to minimize costs. If the occupants and their activities are the principal cause of indoor air pollution, occupancy-based ventilation controls can be most effective.

Detecting occupancy is difficult. Motion detectors are effective unless the occupants are sitting or sleeping quietly or are out of the view of the sensor. Good coverage may require one or more motion detectors in each room. Carbon dioxide sensors can be effective but are expensive. Setting the detection level may be difficult because a sleeping person gives off little carbon dioxide. Thus, it is difficult to distinguish between a house with sleeping people and one that is unoccupied.

### ✓ LOW-HIGH SWITCH

A two-speed fan installed in a whole-house ventilation system might be controlled by a low-high switch. This allows the ventilation fan to provide a low level of ventilation continuously, but provides the occupant with the capability to boost the ventilation rate if needed.

### ✓ LABELING

If a ventilation control switch is used, it should be labeled to provide clear guidance for its proper operation. For example, it might be labeled to say “This switch controls the ventilation system. It should be ON whenever the home is occupied.”

## DESIGN AND INSTALLATION CRITERIA

### ✓ FANS

Noise is a major reason people avoid using ventilation systems. Fans used in whole-house ventilation systems and installed inside the house should be quiet (less than 2 sones, but preferably less than 1 sone) or installed remotely outside the living space so that the noise caused by their operation is not perceived.

A significant part of the operating cost associated with a ventilation system is the electricity used to operate the fan. Energy-efficient fans should be used to reduce these costs.

Fans should be sized and selected to provide necessary air flows based on the type, length, and design of the duct system. Fans selected for whole-house ventilation systems should be manufactured for continuous operation and long life (greater than 10 years), and installed in a location that is easily accessible for regular maintenance.

### ✓ DUCTS

The most efficient ventilation ducts are smooth, short, straight, and properly sized. Smooth sheet metal ducts offer low airflow resistance. Because corrugated ducts have greater flow resistance, it is important to keep them as short as possible—stretch the corrugated material to its full length and cut off the excess. Minimize the number of elbows. Provide adequate support. Use mechanical fasteners and sealants (preferably duct mastic) at all joints. Ducts located outside the conditioned space should be insulated.

### ✓ DUCT TERMINATIONS

Ducts expelling water vapor or other pollutants must exhaust directly to the exterior—never into attics or crawlspaces prone to moisture problems. Use wall caps or roof jacks with flap dampers, screens, or both to deter access and to reduce air infiltration. Unless they are already integrated into the system (e.g., wall cap with flapper), equip ventilation ducts with backdraft dampers at or near the insulated building boundary.

### ✓ INDOOR AIR CIRCULATION

Indoor air must be free to flow between supply and return ports of whole-house ventilation systems. If a supply and return port is not installed in every room, then through-the-wall transfer grills should be installed above doors in rooms with doors that are often closed, or the doors should be undercut to facilitate air flow.

# WHOLE-HOUSE VENTILATION SYSTEMS

*For more information, contact:*

**Energy Efficiency and  
Renewable Energy  
Clearinghouse (EREC)**  
1-800-DOE-3732  
[www.eren.doe.gov](http://www.eren.doe.gov)

*Or visit the Building  
Technologies Program  
Web site at*  
[www.buildings.gov](http://www.buildings.gov)

*Or refer to the Builder's Guide  
Energy Efficient Building  
Association, Inc.*  
952-881-1098  
[www.eeba.org](http://www.eeba.org)

*Written and prepared for the  
U.S. Department of Energy by:*

**Southface Energy Institute**  
404-872-3549  
[www.southface.org](http://www.southface.org)

**U.S. Department of Energy's  
Oak Ridge National  
Laboratory**  
*Buildings Technology Center*  
865-574-5206  
[www.ornl.gov/btc](http://www.ornl.gov/btc)

**U.S. Department of Energy's  
National Renewable Energy  
Laboratory**  
303-275-3000  
[www.nrel.gov/buildings](http://www.nrel.gov/buildings)

*NOTICE: Neither the United States government nor any agency thereof, nor any of their employees, makes any warranty, express or implied, or assumes any legal liability or responsibility for the accuracy, completeness, or usefulness of any information, apparatus, product, or process disclosed. The views and opinions of authors expressed herein do not necessarily state or reflect those of the United States government or any agency thereof.*

## STEPS FOR DESIGNING A WHOLE-HOUSE VENTILATION SYSTEM

1. Air seal the house as much as reasonably possible, especially the foundation, garage, or other spaces from which polluted air could be drawn.
2. Choose building materials, paints, furnishings, etc., to minimize emissions of VOCs and other pollutants.
3. Select a general ventilation design strategy appropriate for the climate. Consider the type of heating and cooling system to be installed, operating costs of the ventilation system, impact of the ventilation system on heating and cooling operating costs, installation costs, and the desire or need for filtered air (an important consideration for people with asthma, allergies, and other environmental sensitivities). Ensure that depressurization will not lead to moisture damage in wall cavities in humid climates or introduction of pollutants from outside the house, and that pressurization will not lead to moisture problems in cold climates.
4. Determine the house's ventilation requirements by consulting ASHRAE and local codes. A continuous ventilation rate of 50 to 100 cfm is typical.
5. Design the whole-house ventilation system and select appropriate equipment and controls to meet the determined ventilation requirement. In developing the design, keep operating costs (especially fan costs) as low as possible. Keep in mind the contribution of natural ventilation to a house's ventilation requirement. Avoid providing excess ventilation because it can increase heating and cooling costs without significantly improving air quality.
6. Incorporate spot ventilation (i.e., exhausts in kitchens, bathrooms, and other rooms where pollutants are produced) and/or separate spot ventilation systems in the design, following ASHRAE recommendations and local building codes to control moisture and pollution generation at their source.
7. Include both sensible and latent loads induced by the ventilation system in calculations for sizing heating and cooling equipment.
8. After installation, balance and test the system. Make sure ventilation ducts are airtight, design air flows are achieved, control systems work as intended, and controls are clearly and permanently labeled with operating instructions. Provide a homeowner's manual that covers operation and maintenance details, especially for heat-recovery ventilation systems and systems with filters.
9. Consider hiring a specialist to select and design the whole-house ventilation system. Ideally, one engineer should design both the ventilation system and the heating and cooling system, especially if the ventilation system is to be integrated with the heating and cooling system.



Printed with a renewable-source ink on paper containing at least 50% wastepaper, including 20% postconsumer waste.

December 2002 DOE/GO-102002-0778