



PDHonline Course M244 (4 PDH)

Fundamentals of Mechanical Refrigeration Systems

Instructor: A. Bhatia, B.E.

2020

PDH Online | PDH Center

5272 Meadow Estates Drive
Fairfax, VA 22030-6658
Phone: 703-988-0088
www.PDHonline.com

An Approved Continuing Education Provider

Fundamentals of Mechanical Refrigeration Systems

Course Content

Introduction

Mechanical refrigeration is a thermodynamic process of removing heat from a lower temperature heat source or substance and transferring it to a higher temperature heat sink. This is against the Second Law of Thermodynamics, which states that heat will not pass from a cold region to a warm one. According to Clausius Statement of the Second Law of thermodynamics *“It is impossible to construct a device that operates in a cycle and produces no effect other than the transfer of heat from a lower-temperature body to a higher-temperature body”*.

Therefore in order to accomplish the transfer of heat from low temperature region to high temperature region an “external agent” or energy input is required and – you need a device, like a heat pump or refrigerator, which consumes work. The operating principle of the refrigeration cycle was described mathematically by Sadi Carnot in 1824 as a heat engine. A refrigerator or heat pump is simply a heat engine operating in reverse.

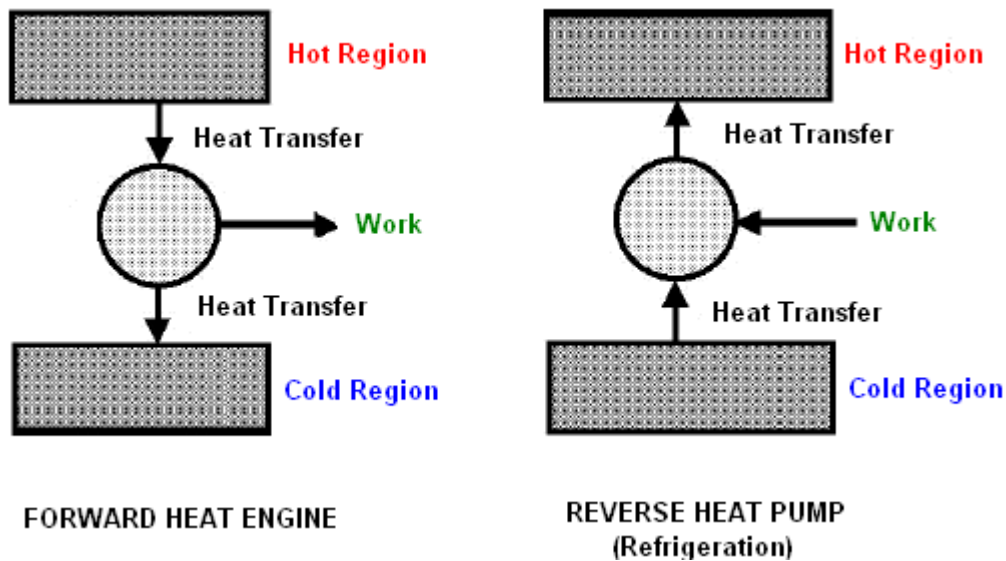

Note the direction of arrows: Heat engine is defined as a device that converts heat energy into mechanical energy whereas the heat pump or refrigerator is defined as a device that use mechanical energy to pump heat from cold to hot region.

A refrigeration system is a combination of components and equipment connected in a sequential order to produce the refrigeration effect. The most common refrigeration system in use today involves the input of work (from a compressor) and uses the Vapor Compression Cycle. This course is an overview of vapor-compression refrigeration cycle, principles of heat generation, transfer and rejection.

Since refrigeration deals entirely with the removal or transfer of heat, some knowledge of the nature and effects of heat is necessary for a clear understanding of the subject. You may refer to the basic thermodynamics and glossary of terms at the end (annexture-1) to help you with this section first time through.

THE VAPOR COMPRESSION REFRIGERATION SYSTEM

You need to know some basic rules of physics to understand the vapor compression cycle:

- 1) Rule-1: Heat naturally flows from hot to cold
- 2) Rule-2: Energy (in the form of heat) is required to change a substance from a liquid to gas (i.e. to boil or evaporate). When this happens the liquid absorbs large amounts of heat. This explains why sweating cools the skin.
- 3) Rule-3: Energy is given out by a substance changing from a gas into a liquid (i.e. liquefying or condensing). This explains why steam is particularly good at heating things on which it condenses.
- 4) Rule-4: The boiling temperature and the condensing temperature change, if the pressure changes. This principle explains why you can't make good tea up a high mountain- the water boils at only about 90°C because of the lower pressure.

Refrigeration Cycle

In a vapor compression refrigeration system a gas (refrigerant) is alternatively compressed and expanded and goes from the liquid to the vapor state. All such systems have four components: a compressor, a condenser, an expansion valve (also called a throttle valve or metric device) and an evaporator. Figure below depicts a typical, single-stage vapor-compression system.

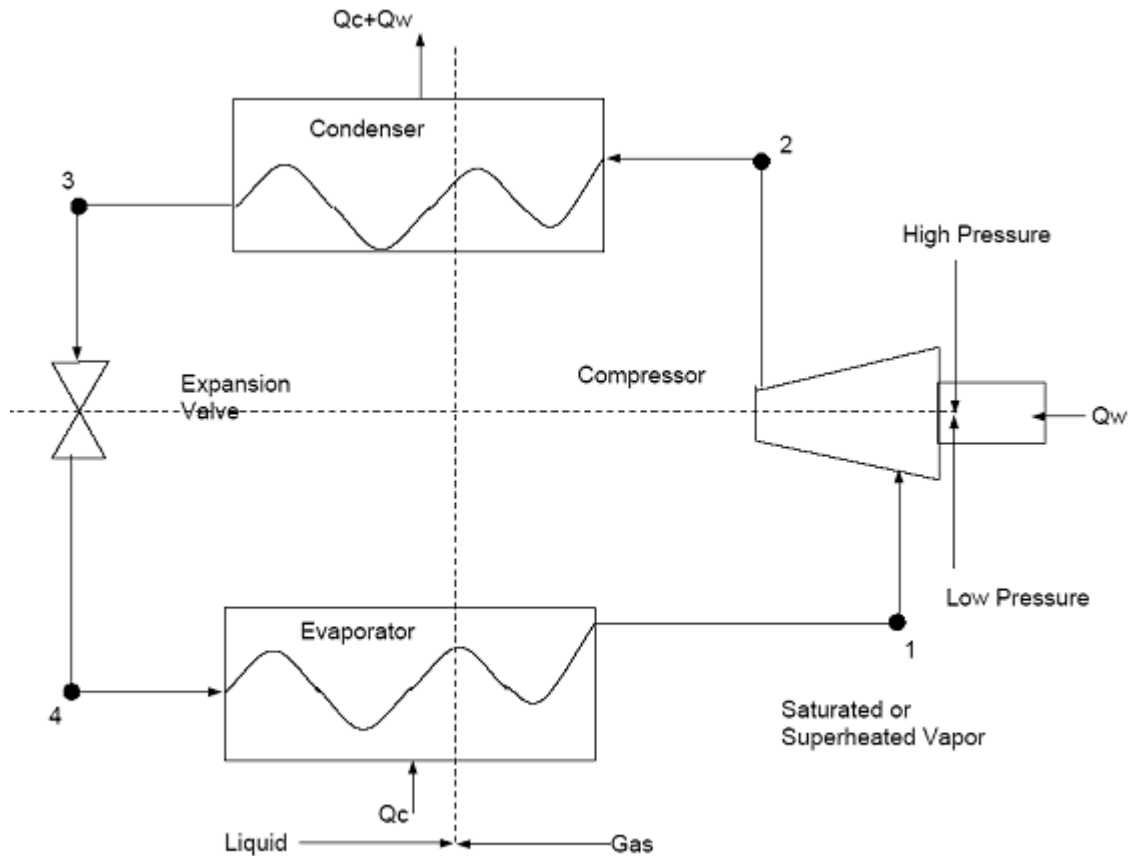

Equipment Layout of a Two-phase Mechanical Refrigeration Cycle

A single-stage refrigeration cycle consists of two regions: the evaporator pressure in the "low side" and the condenser pressure in the "high side". These pressure areas are divided by the other two components; on one end, is the metering device (expansion valve) which controls the refrigerant flow and on the other end is the compressor. The vapor-compression refrigeration system uses a circulating liquid refrigerant as the medium which absorbs and removes heat from the low side and subsequently rejects that heat in the high side. The process involves changes of thermodynamic properties of the refrigerant and the energy transfer between the refrigerant and the surroundings and is illustrated below:

- 1) Evaporation (process 4-1) - In this process, the refrigerant evaporates (liquid to gas) at a lower temperature than that of its surroundings, absorbing its latent heat of vaporization (Q_c). This process of heat extraction at low temperature represents the useful part of the refrigerator. The low pressure necessary for the evaporation at the required temperature is maintained by the suction of the compressor.
- 2) Compression (process 1 -2) - Refrigerant is compressed to a higher pressure and temperature for condensation. The compression process takes the gas from low pressure and low temperature to high pressure and high temperature. Work energy Q_w is required, and is usually provided by an electric motor.
- 3) Condensation (process 2 -3) - Gaseous refrigerant is condensed to liquid form by being desuperheated, then condensed, and finally sub-cooled, giving up its latent heat of condensation to some cooling medium. Heat ($Q_c + Q_w$) is removed from high temperature, high pressure refrigerant vapor in the condenser, which is a heat exchanger cooled generally by water or air.
- 4) Throttling and expansion (process 3- 4) - The higher-pressure liquid refrigerant is throttled to the lower evaporating pressure and is ready for evaporation. The temperature also drops considerably at constant enthalpy. Because of the reduction in temperature and pressure, the refrigerant exits as a two-phase liquid-vapor typically a mixture of 75% liquid, 25% vapor.

The change of state from liquid to vapor and back to liquid allows the refrigerant to absorb heat from a lower-temperature reservoir and discharging it to a higher temperature reservoir very efficiently. The refrigerant is said to have undergone a closed refrigeration cycle. The basis of mechanical refrigeration is the fact that at different pressures the saturation (or the condensing) temperatures of vapors are different as clearly shown on the appropriate vapor-pressure/temperature curve. As the pressure increases condensing temperatures also increase.

Most refrigeration cycles are typically represented by a pressure-enthalpy (P-h) diagram, which shows the phase changes of the refrigeration cycle and provides a graphical means of study. Horizontal lines on the P-h Chart are lines of constant pressure and vertical lines are lines of constant enthalpy or heat energy.

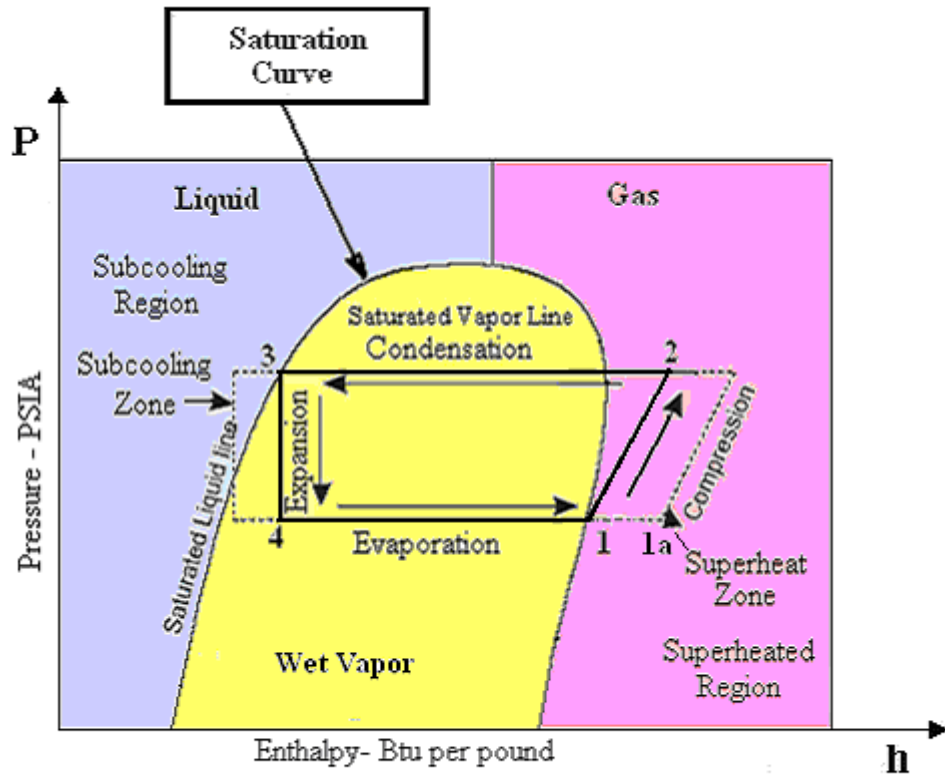

P-h DIAGRAM OF VAPOR COMPRESSION REFRIGERATION CYCLE

The chart is divided into three regions. The area to the left is the sub-cooled region; to the right is the superheated region and in the middle is the wet region or mixture state. The theoretical refrigeration cycle is represented in the P-h diagram by lines 1-2-3-4.

- 1) Process "4-1" – The process '4 – 1' is an internally, reversible, constant pressure heat interaction in which the working fluid (as a mixture of vapor and liquid) is evaporated to a saturated vapor at state point 1. The heat necessary for evaporation is supplied by the refrigerated space surrounding the evaporator (i.e. $Q_C = h_1 - h_4$). During this transfer of heat energy, only latent heat is absorbed resulting in the refrigerant remaining at a constant pressure and constant temperature.
- 2) Process "1-2" - The process '1 – 2' is a reversible, adiabatic (isentropic) compression of the refrigerant from a low pressure gas to a high pressure gas. The saturated vapor at state 1 is superheated to state 2. During the compression process, the refrigerant gas absorbs additional heat known as the "Heat of Compression". The additional heat energy caused by compression is represented by the line between points 1 and 2 and is given by equation $Q_W = h_2 - h_1$. Note that point 2 is to the right of point 1, indicating the additional enthalpy resulting from the Heat of Compression.
- 3) Process "2-3" - The process '2 – 3' is an internally, reversible, constant pressure heat rejection in which the working substance is desuperheated and then condensed to a saturated liquid at 3. The condenser removes the heat of compression plus the latent heat of evaporation, collectively known as the "Total Heat of Rejection", or THR. The total heat rejection is given by equation $Q_H = h_2 - h_3$ and is sum of $Q_C + Q_W$.
- 4) Process "3-4" - The process '3 – 4' through expansion valve is an irreversible process in which the refrigerant vapor is expanded from high pressure to low pressure region. Both temperature and pressure decrease at constant enthalpy (i.e. $h_3 = h_4$).

The process of evaporation at a low pressure and corresponding low temperature, followed by compression, followed by condensation at around atmospheric temperature and corresponding high pressure, is the refrigeration cycle. Because the constant-temperature lines and constant-pressure lines in the middle two-phase (wet vapor) region are horizontal, they are closely related. The specific pressure of a refrigerant in the two-phase region determines its temperature, and vice versa. Overall, the energy side of the refrigeration cycle can therefore be summed up:

- 1) Heat taken in from surroundings at the (low) evaporator temperature and pressure ($Q_C = h_1 - h_4$),
- 2) Heat equivalent to the work done by the compressor ($Q_W = h_2 - h_1$) and
- 3) Heat rejected at the (high) compressor pressure and temperature ($Q_H = h_2 - h_3$).

Note that the amount of heat rejected by the condenser and absorbed by the evaporator is represented as a horizontal (constant pressure) line. The compression path is represented along a constant entropy line, and the expansion process is represented along a vertical (constant enthalpy) line.

Superheat

In theory, the refrigerant leaves the evaporator as a vapor at point '1', however, in real applications, additional heat, called "superheat" is added to prevent liquid condensation in the lines that can damage the compressor (shown as point 1a). Superheat is the heat added to the vapor beyond what is required to vaporize all of the liquid. Since refrigeration and air-conditioning compressors are designed to compress vapor refrigerant, some superheating is necessary to ensure that no liquid refrigerant can return to the compressor. The amount of superheat is determined by the amount of liquid refrigerant admitted to the evaporator. This, in turn, is controlled by the expansion valve (TXV) and that's why it is also known as metering device. A temperature range of 4° to 12°F of superheat is considered desirable to prevent liquid carry-over into the compressor (flooding back).

Superheat is an indication of how full the evaporator is of liquid refrigerant. High superheat means the evaporator is empty. Low superheat means the evaporator is full.

Sub-Cooling

Sub-cooling is the process of cooling condensed gas below its saturated pressure-temperature. Sub-cooling assures that no gas is left at the end of the condensing phase, thus assuring maximum capacity at the expansion valve. Sub-cooling is best accomplished in a separate sub-cooler or a special sub-cooling section of a condenser because tube surface must be submerged in liquid refrigerant for sub-cooling to occur. Sub-cooling can have a dramatic effect in the capacity of a refrigeration system by increasing the capacity of the refrigerant to absorb heat during the evaporation phase for the same compressor kW input.

Refrigeration Equations – Evaluating the Parameters

When it comes to evaluating refrigeration systems, it is important to know how to calculate system parameters such as power input, system efficiency, and cooling capacity. The pressure-enthalpy diagrams are very important in determining these parameters; mainly because the changes in enthalpy can be read easily in this diagram. Let's see the P-h diagram again:

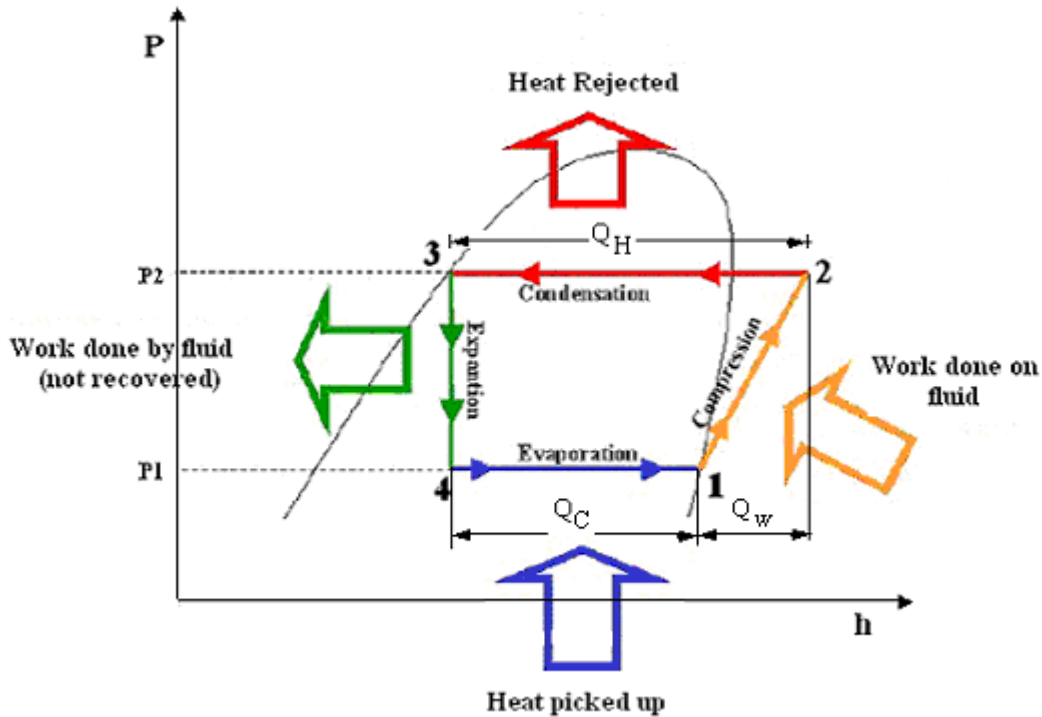

The refrigerant swings between two pressures P_1 and P_2 . At lower pressure P_1 , the heat is absorbed whereas at higher pressure P_2 heat is rejected. By adjusting the high and low pressures, the condensing and evaporating temperatures can be selected as required. The high pressure is determined: by the available cooling-water temperature, by the cost of this cooling water and by the cost of condensing equipment. The evaporating pressure is determined by either the low temperature that is required for the product or by the rate of cooling or freezing that has to be provided. Low evaporating temperatures mean higher power requirements for compression and greater volumes of low-pressure vapors to be handled therefore larger compressors, so that the compression is more expensive. It must also be remembered that, in actual operation, temperature differences must be provided to operate both the evaporator and the condenser. There must be lower pressures than those that correspond to the evaporating coil temperature in the compressor suction line, and higher pressures in the compressor discharge than those that correspond to the condenser temperature.

Using the P-h diagram, we can measure the amount of heat rejected by the condenser, the amount of heat absorbed by the evaporator and the amount of work required by the compressor as the enthalpy difference.

Heat Picked by Evaporator (Q_C)

The amount of heat picked by the evaporator per pound of refrigerant is given by the evaporator process '4-1'. The heat absorption (Q_C) is given by the enthalpy difference ($h_1 - h_4$). This is a constant pressure (and temperature) process where the refrigerant gains in heat content or enthalpy.

$$\frac{Q_C}{m} = h_1 - h_4$$

Where

- m is the mass flow rate of the refrigerant. The heat transfer rate to the refrigerant in the evaporator

- Q_c , is referred to as the refrigeration capacity (RC), it usually being express in kW or in Btu/hr or in tons of refrigeration, one ton of refrigeration being which is equal to 200 Btu/min or about 211 kJ/min

Refrigeration effect is the amount of cooling produced by a refrigeration system.

Heat Rejected by Condenser (Q_H)

The amount of heat rejected by the condenser is given by the condensation process '2-3'. The heat rejection (Q_H) per pound of refrigerant is given by the enthalpy difference ($h_2 - h_3$). We can see that the heat rejected by the condenser is equal to the heat absorbed by the evaporator plus the work done by the compressor.

$$\frac{Q_H}{m} = h_2 - h_3$$

$$Q_H = Q_c + Q_w$$

Unit of Refrigeration

In inch-pound (I-P) units, refrigeration is expressed in British thermal units per hour, or simply Btu/h. A *British thermal unit* is defined as the amount of heat energy required to raise the temperature of one pound of water one degree Fahrenheit from 59°F to 60°F; and 1 Btu/h = 0.293 watt (W).

Another unit of refrigeration widely used is ton of refrigeration (TR), or simply ton. It is equivalent to the heat absorbed by 1 ton (2000 lb) of ice melting at a temperature of 32°F over 24 hour.

Because the heat of fusion of ice at 32°F is 144 Btu / lb,

$$\begin{aligned} 1 \text{ TR} &= (1 \times 2000 \text{ lb} \times 144 \text{ Btu/lb}) / 24 \text{ hours} \\ &= 12,000 \text{ Btu/Hr} \\ &= 200 \text{ Btu/min} \end{aligned}$$

Simply stated, one ton of refrigeration is defined as a heat extraction rate of 12,000 Btu/hr (200 Btu/min), or 3.52 kW.

Refrigeration Capacity

Cooling capacity of a refrigeration machine is expressed in tons of refrigeration.

The refrigeration capacity is normally expressed in tons of refrigeration (1 ton = 200 Btu /min) and is calculated using the following expression:

$$\text{Refrigeration Capacity (RC)} = \frac{m \times (h_1 - h_4)}{200} \text{ ----- (Expressed as tons of refrigeration, TR)}$$

Where

- m = refrigerant flow rate in lbm/min
- h_1 = The suction enthalpy to the compressor (Btu/lbm)
- h_4 = The enthalpy of the refrigerant at the entrance of the evaporator (Btu/lbm)
- TR = Tons of refrigeration (= 200 Btu/min)

Work of Compression (Qw)

The compression process '1 – 2' is a constant entropy or isentropic process where the refrigerant gains in enthalpy equivalent to the work of compression. It is usually adequate to assume that there is no heat transfer to or from the compressor. Conservation of mass and energy rate applied to a control volume enclosing the compressor then give:

$$Q_w = m * (h_2 - h_1)$$

Where

- W/m is the work done per unit mass of refrigerant.

Coefficient of Performance (COP)

The coefficient of performance (COP) is a measure of efficiency of the refrigeration system and is defined as ratio of useful refrigeration (heat removed by the evaporator) to the net work (done by the compressor).

$$COP_R = \frac{\overbrace{h_1 - h_4}^{\text{refrigerating effect}}}{\underbrace{h_2 - h_1}_{\text{specific work}}}$$

Another expression of COP is

$$COP = \frac{T_e}{(T_c - T_e)}$$

Where

- T_e = Evaporator temperature, deg R
- T_c = Condenser temperature, deg R

From the formula, the higher the evaporator temperature, the higher is the COP. The lower the condenser temperature, the better is the COP.

Performance Characteristics

Variations in load and in the evaporating or condensing temperatures are often encountered when considering refrigeration systems. Their effects can be predicted by relating them to the basic cycle.

If the heat load increases, then the temperature tends to rise and this increases the amount of refrigerant boiling off. If the compressor cannot move this, then the pressure on the suction side of the compressor increases and so the evaporating temperature increases tending to reduce the evaporation rate and correct the situation. However, the effect is to lift the temperature in the cold space and if this is to be prevented additional compressor capacity is required.

As the evaporating pressure and resultant temperature changes, the volume of vapor per pound of refrigerant also changes. If the pressure decreases, this volume increases, and therefore the refrigerating effect, which is substantially determined by the rate of circulation of refrigerant, must also decrease.

Therefore if a compressor is required to work from a lower suction pressure its capacity is reduced, and conversely. So at high suction pressures giving high circulation rates, the driving motors may become overloaded because of the substantial increase in quantity of refrigerant circulated in unit time.

Changes in the condenser pressure have relatively little effect on the quantity of refrigerant circulated. However, changes in the condenser pressure and also decreases in suction pressure have quite a substantial effect on the power consumed per ton of refrigeration. Therefore for an economical plant, it is important to keep the suction pressure as high as possible, compatible with the product requirement for low temperature or rapid freezing, and the condenser pressure as low as possible compatible with the available cooling water or air temperature.

TEMPERATURE – ENTROPY (T-s) DIAGRAM

Another way to analyze the vapor compressio cycle is on a Temperature-Entropy (T-s) diagram as depicted in figure below.

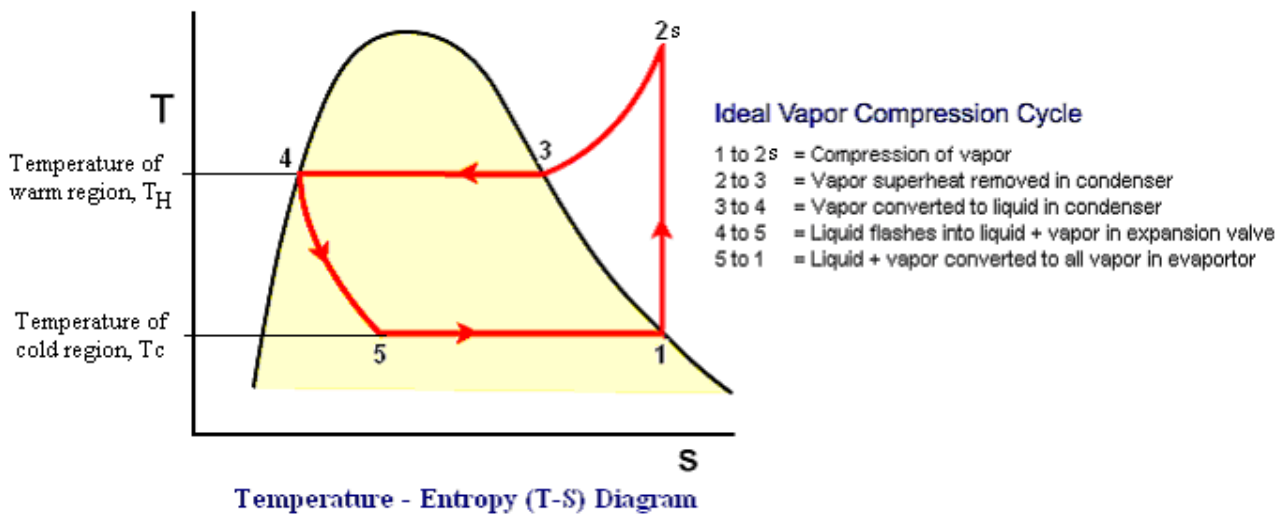

The cycle consists of the following processes:

- 1) From point 1 to point 2s, the vapor is isentropically compressed (constant entropy) and exits the compressor as a superheated vapor. The ideal compression is adiabatic (i.e. $Q=0$) or isentropic (i.e. $dS=0$) because the process should be fast enough not to exchange heat with the surroundings. NB: adiabatic does not mean isothermal, in fact the temperature changes drastically during the compression (together with p and V).
- 2) From point 2s to point 3, the superheated vapor travels through part of the condenser which removes the superheat by cooling the vapor. Between point 3 and point 4, the vapor travels through the remainder of the condenser and is condensed into a saturated liquid. The condensation process occurs at essentially constant pressure.
- 3) Between points 4 and 5, the saturated liquid refrigerant passes through the expansion valve and undergoes an abrupt decrease of pressure. This process results in the adiabatic flash evaporation and auto-refrigeration of a portion of the liquid (typically less than half of the liquid flashes). The adiabatic flash evaporation process is isenthalpic (i.e., occurs at constant enthalpy).
- 4) Between points 5 and 1, the cold and partially vaporized refrigerant travels through the coil or tubes in the evaporator where it is totally vaporized by the warm air (from the space being refrigerated) that a fan circulates across the coil or tubes in the evaporator. The evaporator operates at essentially

constant pressure. The resulting saturated refrigerant vapor returns to the compressor inlet at point 1 to complete the thermodynamic cycle.

All these processes are internally reversible except throttling process. Despite the inclusion of this irreversible process, the cycle is normally referred to as the ideal cycle.

Actual Refrigeration Cycle (Non-Ideal)

The ideal vapor compression cycle does not take into account real world items like fluid friction, heat transfer losses, slight internal irreversibility during the compression of the refrigerant vapor or non-ideal gas behavior (if any). The following are some of the primary ways that actual vapor-compression cycle deviates from an ideal cycle:

- 1) Saturation States - In the ideal vapor-compression cycle, the refrigerant leaves the evaporator as a saturated vapor and leaves the condenser as a saturated liquid. In an actual vapor-compression cycle, it is much more likely that the refrigerant leaves the evaporator as a superheated vapor and the condenser as a sub cooled (or compressed) liquid.
- 2) Non-Isobaric Processes - In the ideal vapor-compression cycle, the refrigerant undergoes isobaric processes as it passes through the evaporator and condenser. In reality, a pressure drop occurs as the refrigerant flows through these components. The pressure drop between the outlet of the evaporator and the inlet of the compressor can be particularly large. This large pressure drop is due to the fact that the refrigerant is a low pressure vapor and therefore has a large specific volume, which results in very high refrigerant flow velocities and significant pressure losses due to friction.
- 3) Compression - The compression process in an ideal vapor-compression cycle is assumed to be both adiabatic and reversible, and therefore isentropic. However, any real compression process is neither adiabatic nor reversible. The compression process is not exactly isentropic but will swing further out to the right. This will increase the work of compression.
- 4) Expansion - As the refrigerant passes through the expansion valve, the process is not exactly constant enthalpy process but will lose enthalpy due to the friction in the liquid line. This will result to a reduction in the refrigeration effect.

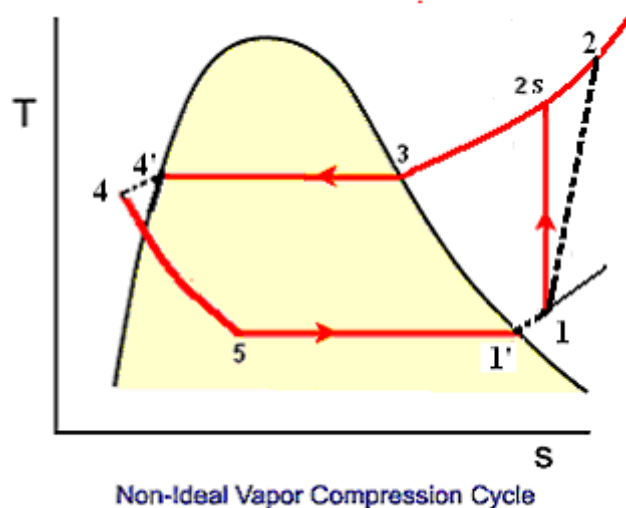

Comparing cycle 1-2-3-4-5-1 with the corresponding ideal cycle 1- 2s-3-4-5-1, it will be seen that the refrigeration capacity is the same for each, but the work input is greater the case of irreversible compression than in the ideal cycle. Accordingly, the coefficient of performance of actual cycle is less than that of ideal cycle. This difference is the departure from an isentropic process due to internal irreversibility's present during the actual compression process. The actual process is indicated in the T-s diagram by the dashed line for the compression process from state 1 to state 2. However, if sufficient heat transfer occurred from the compressor to its surroundings, the specific entropy at state 2 could be less than at state 1. When designing a refrigeration system, it is important to understand how the actual refrigeration cycle works and the effects of component inefficiency on overall performance.

Refrigeration Cycle for Cooling and Heating

Thermodynamic cycles can be broadly classified as either power or refrigeration cycles based on the direction of the energy transfer to/from the hot and cold regions by heat transfer, and whether the cycle requires or produces net work. Refrigeration cycles can also be distinguished based on the desired energy flow.

- 1) When we are interested in the heat energy to be removed from a low temperature space, the device is called a refrigerator or air conditioner. The desired energy flow for refrigeration is heat transfer from the cold region to the refrigerant, which provides the cooling to the cold region.
- 2) When we are interested in the heat energy supplied to the high temperature space, the device is called a heat pump. The desired energy flow for heat pumps is the heat transfer from the refrigerant to the hot region, which provides the heating to the hot region.

The figure below shows the objectives of refrigeration and heat pumps.

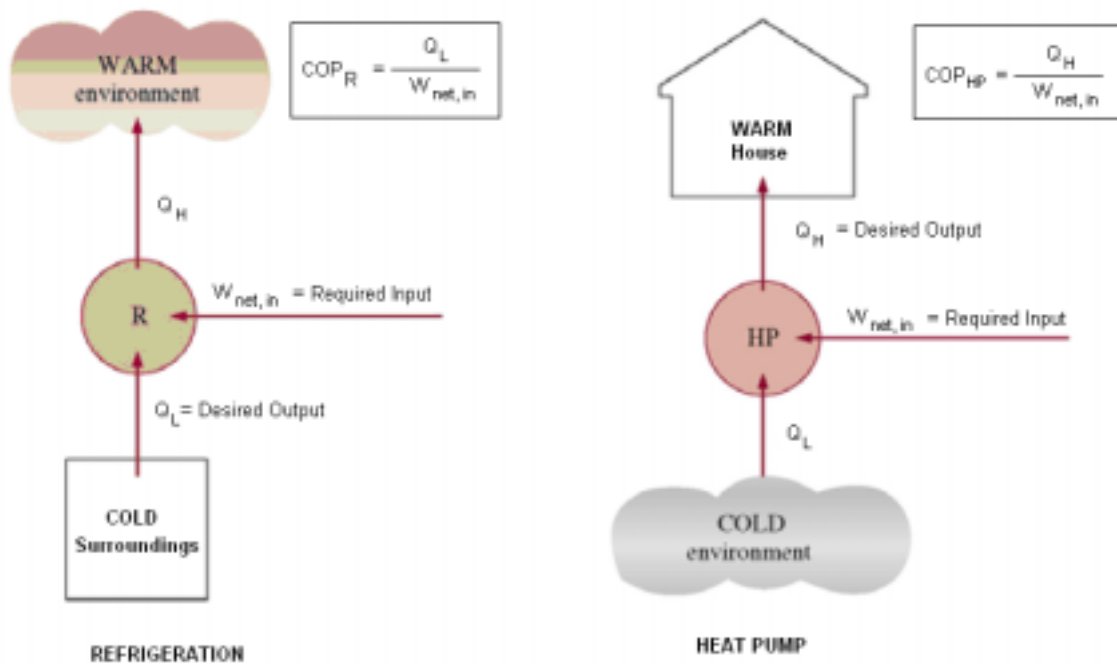

A refrigerator or heat pump operates on the reversed Carnot cycle and their performance is expressed in terms of coefficient of performance (COP). In case of heat pump, it is the ratio of the output heat to the supplied work or

$$COP = \frac{|Q|}{W}$$

Where

Q is the useful heat supplied by the condenser and W is the work consumed by the compressor.

(Note: COP has no units, therefore in this equation, heat and work must be expressed in the same units)

According to the first law of thermodynamics; $W = Q_{hot} - Q_{cold}$, where Q_{hot} is the heat given off by the warm heat reservoir and Q_{cold} is the heat taken in by the cold heat reservoir.

Therefore, by substituting for W

$$COP_{heating} = \frac{Q_{hot}}{Q_{hot} - Q_{cold}}$$

Or

$$COP_{heating} = \frac{T_{hot}}{T_{hot} - T_{cold}}$$

Similarly

$$COP_{cooling} = \frac{Q_{cold}}{Q_{hot} - Q_{cold}} = \frac{T_{cold}}{T_{hot} - T_{cold}}$$

Both COP_R and COP_{HP} can be larger than 1. Under the same operating conditions, the COP are related by

$$COP_{cooling} = COP_{heating} - 1$$

Because the COP can be greater than 1, COP is used instead of thermal efficiency.

Factors affecting the COP

The COP varies depending on the temperature lift of the system – the temperature lift is the difference between the evaporating and condensing temperatures. The capacity of the compressor increases when the temperature lift reduces. The temperature lift reduces when the condensing temperature is lowered or when the evaporating temperature is raised. An increase of 1°C in evaporating temperature or a reduction of 1°C in condensing temperature will increase the compressor COP by 2 – 4%. Or put another way, a decrease of 1°C in temperature lift will cut running costs by 2 – 4%.

The condensing temperature will be lower if:

- 1) A condenser with a high basic rating is used (this is usually a larger condenser)
- 2) The condensing temperature is allowed to float down with the ambient temperature.
- 3) Water is used instead of air as the condenser cooling medium (but don't forget to include the fan motors and pumps associated with water-cooled condensers and cooling towers in the COP calculation).

- 4) It is also important that condensers do not become blocked, or their flow of cooling air or water becomes impeded in any other way.

The evaporating temperature will be increased if:

- 1) An evaporator with a higher basic rating is used (this is usually a larger evaporator).
- 2) The evaporator is defrosted when necessary.

Other Factors affecting the COP of the system

- 1) The efficiency of different compressor types and manufacturers varies, and not necessarily according to price – it is important that the most efficient compressor for a particular application is carefully selected. This depends on the size of the cooling load, the refrigerant used, the temperature of the application, and the average temperature of the cooling medium (i.e. ambient air or water).
- 2) The amount of refrigerant has a significant effect on the temperature lift – too much or too little refrigerant charge reduced efficiency. Systems that leak refrigerant consume more power than necessary. Systems that are overcharged can, in certain cases, also consume more power than necessary and have more refrigerant to lose in the case of a leak.
- 3) The refrigerant type also has an effect on energy use. The variation can be as high as 10%, but this benefit can only usually be achieved when the hardware is optimized to suit the refrigerant chosen. The most efficient refrigerant for an application depends on the compressor used, the temperature of the application and average temperature of the cooling medium (i.e. ambient air or water).
- 4) The superheat of the suction vapor should be as low as possible – warmer vapor reduces the capacity of the compressor without reducing its power input. On direct expansion (DX) systems, this is achieved by correctly controlling the expansion device, and on all system types, by insulating the suction line.
- 5) The amount of sub-cooling of the liquid refrigerant entering the expansion device should be as high as possible – this increases the capacity of the system without increasing the power input. The liquid line should not be insulated and should not pass through hot areas (e.g. kitchens or direct sunlight).

Coefficient of System Performance (COSP)

The term Coefficient of Performance (COP) is just the efficiency of the compressor. The energy efficiency of a complete refrigeration system is expressed as the Coefficient of System Performance (COSP), which takes into account the power input of all other auxiliaries such as fan motors and pumps associated with the system.

$$COSP = \frac{\text{Capacity}}{\text{Total Power}} = \frac{Q_{\text{Evap}} \text{ (Watts)}}{W_{\text{input}} \text{ (Watts)}}$$

The Energy Efficiency Ratio (EER)

Another common term used for refrigeration systems is the Energy Efficiency Rating, or EER.

The EER is simply a ratio calculated by dividing the cooling capacity in Btu/hr by the power units in watts under ARI specified test conditions, expressed in Btuh/watt.

$$EER = \frac{Q_{\text{in, Evap}} \text{ (Btu/hr)}}{W_{\text{in, Comp}} \text{ (W)}}$$

Since 1 watt = 3.41 Btu/hr

$$\text{EER} = \text{COP} \times 3.41$$

Knowing the EER of a system makes it convenient to calculate the cost of operation once the cooling load is specified in US units.

Note that COP is a ratio of the useful energy output of a system versus the amount of work or energy put in to the system as determined by using the same energy equivalents for energy in and out. It is equal to the energy efficiency ratio (EER) divided by 3.412. The higher the COP, the more efficient shall be the device.

Summarizing

- 1) The purpose of the compressor is to draw the low pressure refrigerant vapor from the evaporator and compress it to a higher pressure. Refrigerant entering the compressor is a low pressure, superheated vapor. Superheated suction gas prevents liquid refrigerant from potentially causing damage to the compressor.
- 2) High pressure, high temperature vapor leaving the compressor is known as discharge gas.
- 3) The changing of vapor to a liquid at a particular pressure and temperature by removing heat is known as condensation.
- 4) Compression raises the temperature and pressure of the refrigerant and the result in temperature increase is superheat.
- 5) Heat is removed from high temperature, high pressure refrigerant vapor in the condenser. Refrigerant leaves the condenser as a high pressure, sub-cooled liquid.
- 6) Refrigerant absorbs heat in the evaporator and releases it in the condenser.
- 7) The component of the refrigeration cycle that absorbs heat is the evaporator. Refrigerant leaving the evaporator will be low pressure, superheated vapor.
- 8) The evaporator is the element of the refrigerating circuit through which heat is absorbed from the environment that is being cooled.
- 9) The temperature of liquid refrigerant cooled below its saturated pressure-temperature is called sub-cooling. Sub-cooled liquid from condenser reaches the metering device through the liquid line.
- 10) A thermostatic expansion valve is a type of metering device. As refrigerant passes through the metering device, it becomes a mixture of 75% liquid, 25% vapor.

PART –II REFRIGERATION CIRCUIT AND COMPONENTS

There are four main components in a vapor compression refrigeration system:

- 1) Evaporator - Heat is absorbed to boil the liquid at a low temperature, therefore a low pressure must be maintained in this section.
- 2) Compressor - The compressor does work on the system increasing the pressure from that existing in the evaporator (drawing in low- pressure, low-temperature saturated vapor) and to that existing in the condenser (i.e., delivering high pressure and high temperature vapor to the condenser).
- 3) Condenser - The high pressure, high temperature (superheated or saturated) vapor that enters the condenser has heat removed from it and as a result it is condensed back into a liquid phase.
- 4) Expansion valve - The high pressure liquid from the condenser is expanded through this valve, allowing its pressure to drop to that existing in the evaporator.

The vapor compression system is a closed loop cyclic process with four main components connecting through copper tubing (Note: copper tubing is not applicable for ammonia refrigerant).

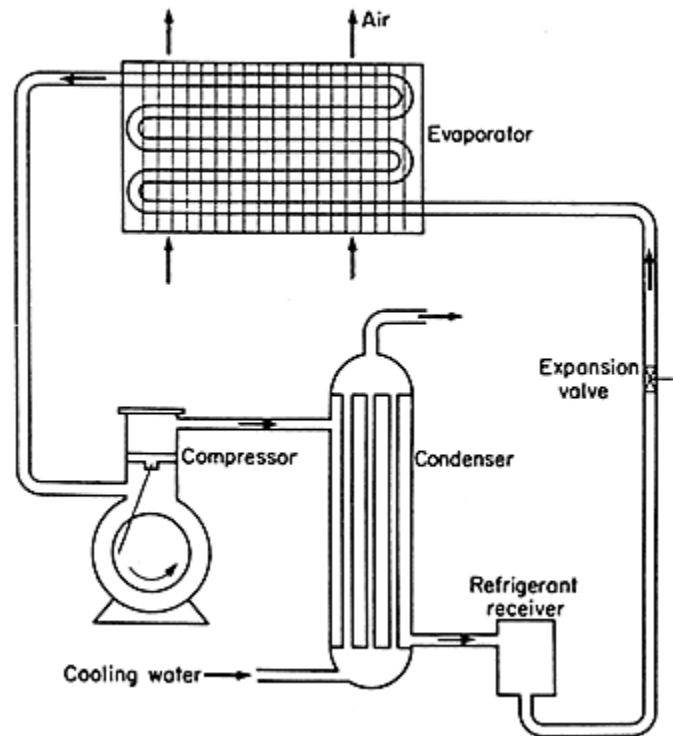

Mechanical refrigeration circuit

THE EVAPORATOR

Evaporator is the name given to any heat exchanger where the refrigerant is evaporated to vapor at low temperature and therefore at low pressure, but usually above atmospheric pressure to prevent gas and/or water vapor leakages into the low-pressure circuit. Depending on the application, evaporators are made in a series of different versions. Particular differences will occur between these for cooling air or for cooling liquid.

AIR COOLING EVAPORATORS

Air-cooling evaporators can operate under natural convection, where air movement is governed by differences in air density (natural convection systems) or under forced or mechanical convection when fans or blowers are employed to expedite air movement over the cooler and to facilitate air distribution inside the cold room.

1) *Natural convection systems*

Natural convection systems have two main advantages: no energy is needed for air circulation and the desiccation of the produce is much less because air velocities are much lower and relative humidity is high. There are obviously some drawbacks, first, in their defrosting and, second and more important, in their low overall heat exchange coefficient owing to low air velocities over the evaporator that lead to large exchange surface areas, making them bulky and very expensive. Their cost, including installation in the cold chamber, is from three to four times that of a forced convection evaporator because the exchange surface is larger, and erection in the chamber is difficult and time-consuming. Factory-built coil-and-baffle assemblies facilitate installation and can be used for almost any natural convection application. Natural convection grids can be uniformly distributed under the ceiling, leaving enough space for good air circulation (never less than 8 cm), and also along the chamber walls, if there is not enough head space.

2) *Forced convection or forced draught evaporators*

Forced draught evaporators have been developed because the higher overall heat transfer coefficient achieved by rapid air circulation over the coils permits a drastic reduction in evaporator surface areas. Further, they have great refrigerating capacity. Air velocities through the evaporator must be in the range of 300 to 600 ft/min (~1.5 to 3 m/s) to achieve a high heat-transfer coefficient, but it should be borne in mind that velocities above 600 ft/min (3 m/s) will tend to carry moisture deposited on the coils toward the produce. The throw draught must be sufficiently far-reaching to achieve uniform air circulation and an even temperature distribution in the cold store/space.

The evaporator surfaces are often extended by the use of metal fins that are bonded to the evaporator pipe surface. The reason for this construction is that the relatively high metal conductance, compared with the much lower surface conductance from the metal surface to the air, maintains the fin surface substantially at the coil temperature. A slight rise in temperature along the fin can be accounted for by including in calculations a fin efficiency factor. The effective evaporator area is then calculated by the relationship

$$A = A_p + \phi A_s$$

Where

- A is the equivalent total evaporator surface area
- A_p is the coil surface area, called the primary surface
- A_s is the fin surface area, called the secondary surface and
- ϕ (phi) is the fin efficiency

Values of ϕ lie between 65% and 95% in the usual designs.

Fin size and spacing depend on the operation and fundamentally on the operating temperature. Fin height should usually be equal to the diameter of the tube and the fin should be thick enough to provide mechanical resistance (0.7-1 mm). Fin spacing is between 6 and 10 mm or more for chilling rooms or 15 mm or more for freezer rooms, to minimize the risk of ice block. Sometimes fins are spaced wider at the coil air inlet to act as a frost catcher and to avoid obstruction of the air flow.

LIQUID COOLING EVAPORATORS

The liquid cooling evaporators come in various types such as 1) shell and tube cooler; 2) Plate heat exchanger liquid cooler and 3) Baudelot Liquid Coolers.

1) *Shell and tube cooler*

The shell and tube liquid cooler comes in two types 1) direct expansion system and 2) the flooded system. In a direct expansion system, the refrigerant is metered into the tubes by a thermostatic expansion valve. The process fluid flows through the shell side of the unit, over the tubes, between the baffles that ensure the fluid is in cross flow to the refrigerant flow. This is discussed in detail later in this section.

2) *Plate heat exchanger liquid coolers*

In a plate heat exchanger, the refrigerant and the fluid to be cooled flow through channels formed in an assembly of corrugated plates, either brazed or bolted together. Plate heat exchanger evaporators can operate on either the flooded principle or by direct expansion.

The advantages of plate heat exchanger cooler over shell and tube evaporators are:

- Higher heat transfer coefficients
- A smaller temperature difference between the refrigerant and the cooled liquid, resulting in higher evaporating temperature and therefore improved system efficiency
- More compact units requiring less plant room space
- Smaller refrigerant charge
- The ability to clean non-brazed assemblies thus maintaining a good heat transfer capability

3) *Baudelot Liquid Coolers*

This type of cooler is used to cool down a fluid, most commonly process water, close to freezing temperature, usually to within 0.5°C of the freezing point. The cooler is designed in a way so that it will not be damaged if the water freezes.

The usual type has the water running down in a thin film over the outside of the refrigerant tubes or plates and collected in a storage tank at the base. Several designs are used, with either the refrigerant coil wound from steel tube or vertically embossed stainless steel plates.

SHELL AND TUBE EVAPORATORS

Shell & tube evaporators fall into two categories, depending on the way they are fed with liquid refrigerant: direct expansion and flooded.

1) *Dry Expansion System*

In dry expansion operation, the evaporator tubes receive the fluid from thermostatic expansion as a mixture of liquid and a small proportion of vapor. The fluid to be cooled circulates on the shell side and moves up and down across the baffles places outside of the tubes. The refrigerant leaves the evaporator totally evaporated and slightly superheated, about 2–4°C above the evaporation temperature; this avoids any risk of liquid reaching the compressor.

The thermostatic expansion valve is the most commonly used device but there are others: capillary tubes for very small equipment, automatic expanders, and hand-operated valves or calibrated orifices for industrial plants operating in stable conditions. When thermostatic expansion valves are used in commercial and industrial equipment they are externally equilibrated.

2) *Flooded System*

In flooded evaporator, the fluid to be cooled is passed through the tubes, with the evaporating refrigerant boiling off into vapor within the body of the shell. The refrigerant level in the shell is maintained so that the top tube is always covered with liquid. In this way, the most efficient heat exchange, liquid to liquid, is achieved over the whole of the cooling surface. To ensure optimum efficiency, the liquid level is usually maintained by using a low pressure float valve. Alternatively, an expansion device and level sensor can be used.

Flooded system require locally mounted surge drums from which liquid refrigerant is fed by gravity. With pumped circulation units, a single remote mounted drum can serve a number of coolers. Rotary pumps distribute the liquid refrigerant to the units. Both methods of liquid supply achieve a fully wetted heat transfer surface, giving an increase in capacity over a direct expansion-type cooler.

- Gravity System Flooded Evaporators - When flooded evaporators are fed by gravity, this can be achieved from a single liquid separator or accumulator that serves all the evaporators, which are run in parallel. The separator should be of the right size to avoid liquid carry-over and a vapor velocity under 0.4 m/s should be maintained.

Another gravity design has a liquid separator for every evaporator, so the number of expansion valves is equal to the number of separators. This system is used when a single separator is not enough for correct feeding to all the evaporators, as when pressure losses are excessive, and in large cold chambers and freezing and chilling tunnels. In all cases the pipes should be of adequate diameter to prevent undue pressure loss. Pipes to and from the evaporator and separators must be thermally insulated.

- Mechanical Pump Flooded Evaporator - Flooded evaporators use a mechanical pump to circulate liquid refrigerant in the evaporator-separator circuit at a rate high enough to return the fluid to the separator in a wet vapor state. The flow rate recommended to achieve a high overall heat-transfer coefficient is in the range of three to eight times the rate of refrigerant vaporization, dependent on the heat load of the chamber. The low-pressure liquid separator or surge drum is placed in the machine room and the pressure losses in the refrigerant circuit are counteracted by the pump, not by the compressor, which is useful when operating at low temperatures. All the evaporators in a single circuit should be fed in parallel using at least two pumps, one operational and one standby, isolating each evaporator with a solenoid valve under the control of the room thermostat. When these valves are closed the liquid refrigerant is recirculated to the liquid separator.

Main Advantages of Flooded System

- 1) One of the main advantages of the flooded system is a great heat-transfer coefficient, because boiling liquid completely wets the internal surface of the evaporator; the lower the vapor content at the exit of the evaporator, the greater this coefficient, so it is advisable to employ pump circulation to increase the liquid: vapor ratio.
- 2) With flooded and pumped circulation coolers, a higher evaporating temperature than that used with direct expansion type units can be achieved as no unnecessary superheat is required to prevent liquid flooding to the compressor. The temperature difference between air and boiling refrigerant is kept in the range of 4° to 5°C, which is possible because the high heat-transfer coefficients and flooding operation assure high efficiency over the entire evaporator surface.

Disadvantages of Flooded System

The main disadvantages of flooded evaporators are that they are usually bulky, and they require a relatively high refrigerant charge.

Cautions

- 1) Some care should be taken when designing a low-pressure circuit. The suction pressure should be increased as the evaporator temperature must be kept as high as possible. This is achieved by choosing the correct size for the evaporator transfer area, limiting pressure losses between evaporator and compressor by using the right pipe diameter and short pipes between them, and lastly, avoiding too frequent or too little defrosting.
- 2) When suction pressure is unduly low it may be because of poor feeding of the evaporator or that it is not fed at all. There are several reasons for both irregular situations: the expansion valve may be obstructed, the solenoid valve may not be in operation (closed when out of order), too high a compressor capacity for the evaporator capacity (the capacity control of the compressor is not in operation or there is too much frost on the evaporator), the constant pressure valve placed downstream to the evaporator may not be correctly adjusted, or the lower pressure limit for valve closing may be too high so that suction pressure is excessively reduced.
- 3) When the evaporators in the same circuit are operating at different temperatures several compressors or a single compressor provided with capacity control must be installed for their correct performance. The evaporators operating at higher temperatures must be equipped with constant pressure valves located downstream. These can be replaced by two temperature thermostatic valves providing the same control.
- 4) To prevent a delay in compressor cycling-in in relation to fluid refrigerant feeding of the evaporator it is necessary to set up an intake valve before the evaporator, served by the compressor operation. This valve obviates any risk of liquid dragging to the compressor.
- 5) Flooded systems are usually employed in high-capacity ammonia plants. They cannot be used with halocarbon refrigerants because of oil problems, unless a rectifier is placed in the low-pressure circuit to ensure the return of oil to the compressor.

EVAPORATOR DEFROSTING

Whenever the evaporator operates at temperatures below 32°F (0°C) a layer of frost is deposited on the exchanger surface, increasing its thickness with time. Frost, a solid phase, is the result of moisture condensation and solidification which is deposited by the air circulating in the space. Frost deposit on evaporator reduces the overall heat exchange coefficient because of the thermal resistance of ice and also hinders air circulation. The decrease in the heat exchange makes the compressor work for longer periods, and also lowers the refrigerant boiling temperature. Both factors increase energy consumption. Therefore defrosting is an important and necessary requirement.

Types of Defrosting

There are several ways to defrost an evaporator and occasionally one of the following or more than one can be used simultaneously.

- 1) Natural defrosting – is possible if the air temperature is above 40°F (~4°C). This is accomplished by keeping the fans running and switching off the refrigeration system.
- 2) Mechanical defrosting- Frost is removed by scraping the evaporator tubes- used only on exposed tubes.

- 3) Thermal defrosting- Heat to melt frost is supplied from either inside or outside the coil tubes.
- 4) Internal heating by hot gases or hot liquid refrigerant - Hot discharge vapor or warm saturated vapor from the top of the receiver is circulated through the evaporator to melt the ice.
- 5) External heating by air, water or antifreeze solution- Heat is transmitted to the outside layers of ice, melting progressing from the outside to the coil tube surface.
- 6) Electric defrosting – defrost heaters, embedded in the fin block, are periodically switched on to defrost the fin block while the compressor is switched off

Choosing the Right Defrosting Method

Defrosting is an expensive operation which uses significant energy. Therefore it is important to choose the right defrosting method and decide on optimum defrosting frequency.

- 1) Hot gas defrosting is used for direct expansion systems. High-pressure hot refrigerant vapor discharged by the compressor is circulated through the evaporator, which acts as a condenser, and the latent heat of the vapor is absorbed by the melting frost. The refrigeration circuit is inverted. The system is complicated but often used because of its efficiency; it is recommended for relatively high-capacity installations. During defrosting, the compressor must be in operation but the fans are stopped.
- 2) Defrosting by hot liquid refrigerant is employed for industrial refrigeration installations with several evaporators. The evaporators are defrosted in succession by the hot pressure liquid which is sub-cooled before entering another evaporator. Only sensible heat is involved in this operation, and liquid temperature cannot be lowered below 0°C. Heat exchange is low, demanding long defrosting periods. Melting ice heat is recovered.
- 3) Air defrosting can be used only in chilled chambers at temperatures above zero, 2°C or higher. The temperature in the room must be allowed to rise to 3–4.5°C but this sometimes represents too high a fluctuation of storage temperature. Fan operation is continued to accelerate heat exchange. The method is simple but seldom used in industrial installations as it presents serious difficulties: products close to the evaporator receive a direct flow of humid air, frequently carrying water droplets; air circulation is maintained for long periods and this leads to mass losses; the efficiency of defrosting is very low.
- 4) Water defrosting is achieved by spraying water on to the evaporator by means of a grid of tubes placed above it. Not only melted ice but some flakes may drop on the collecting tray, so care must be taken to ensure the drain is not blocked. Pipes and surfaces should be correctly sloped down, avoiding bending the pipes which could form a siphon. The water feeding pipe must not be in direct contact with the evaporator. This is a simple method, mainly used in industrial installations operating at temperatures close to or slightly below 0°C. However, there are some drawbacks. Water consumption is high (some 8–10 kg of water per kg of ice; warm water from the condenser is sometimes used to reduce this quantity) and defrosting heat is not recovered.
- 5) Electric heat defrosting though included in external heating methods, supplies heat by electric resistances located around the evaporator tubes or even inside them, provided that enough electric insulation and tightness is assured. The simplest method consists in placing electric resistances close to the evaporator tubes. Electric defrosting has the advantage of being simple and is readily controlled automatically. The installation cost is not high but it is costly in energy. The main inconveniences of the system are that energy is not recovered and that the quality of the electrical insulation of the equipment must be very good. It is suitable for all types of installation but it should be restricted to small-capacity equipment.

- 6) Antifreeze liquid defrosting utilizes water solutions of ether or propylene glycol to keep the evaporator surface continuously free of frost. This method has the advantage of maintaining a high and constant overall heat transfer coefficient. As the antifreeze solution absorbs moisture its concentration will gradually decrease; to regenerate it heating is necessary. The heating of the solution means a considerable increase in the heat load. Other inconveniences are the possibility of solution being splashed on produce at the rear (this can be prevented by installing dampers) and pollution from the solution, which demands a periodic change. This method is recommended for low temperature evaporators which must be constantly preserved without frost, such as in continuous freezing equipment.

An optimum defrosting frequency must also be established. If the frequency is too low the heat transfer coefficient and air circulation deteriorate and equipment efficiency decreases. If the frequency is very high the thermal load increases and the total efficiency of the system is reduced. The periods between defrosting may be relatively long in dry climates but they will be much shorter in equatorial regions. They are also longer in summer than in winter.

Natural convection evaporators need to be defrosted only once a day, starting the defrost cycle usually around midnight and continuing for several hours. Forced convection units with finned coils should be defrosted at least once every three to six hours.

Defrosting can be conducted automatically or manually when the frequency is low. Automatic defrosting is controlled by a clock-timer that functions during fixed periods at regular intervals.

Evaporating Efficiency Issues

The evaporating temperature must be as high as possible to maintain evaporator efficiency. Using a large evaporator achieves this, but in addition:

- 1) The cooling effect of the evaporator is governed by a) the difference in temperature between the medium being cooled and the evaporating refrigerant. The wider the temperature difference the greater the rate of heat transfer and b) the size and design of the evaporator.
- 2) In a direct expansion air cooler the fin block should be kept clear of dirt and slime and adequately defrosted.
- 3) The tubes in a shell and tube evaporators should be cleaned to prevent fouling and corrosion (water may need to be treated to reduce such problems).
- 4) The cooling medium flow should be maintained- pump and fan motors must work.
- 5) Compressor lubricating oil flows around the system with the refrigerant. It is important that this oil returns to the compressor, but it can drop out of solution with the refrigerant in the evaporator. Oil control in evaporators is, therefore an important issue. In order to maintain the optimum efficiency, it is important that oil is not allowed to collect in the evaporator where it will coat the tubes and reduce heat transfer.
- 6) In direct expansion evaporators an adequate refrigerant velocity must be maintained to carry the oil through both the tube assembly and suction line and thus return it to the compressor at all load conditions. With flooded evaporators the oil can be removed if necessary – the method will depend on the refrigerant.
- 7) The flow of refrigerant through the evaporator should be correctly controlled to ensure full use of its capacity with minimum superheat

- 8) Evaporators for natural air circulation are used less and less because of the relatively poor heat transfer from the air to the cooling tubes.
- 9) Evaporator yield is increased significantly, if forced air circulation evaporators are used. With an increase of air velocity the heat transfer from air to tube is improved so that for a given cold yield a smaller evaporator surface than for natural circulation can be used.

COMPRESSORS

The compressor is the active element of the refrigerating circuit. It has two functions: a) to maintain the pressure by drawing off the vapor produced through evaporation of the liquid refrigerant and b) to compress the vapor by raising its temperature and pressure to the point at which the vapor can be condensed at the normal temperature of the condensing media.

The only way the vaporized refrigerant can be made to give up the latent heat of vaporization that it absorbed in the evaporator is by cooling and condensing it. Because of the relatively high temperature of the available cooling medium, the only way to make the vapor condense is to compress it. When we raise the pressure, we also raise the temperature. This enables the vapor to be condensed back into liquid by some convenient low cost source of cooling, such as ambient air or water.

The compressors are designed to compress only the vapors. Refrigerant entering the compressor should be superheated vapor. It's possible to have liquid refrigerant returned to the suction side of a compressor due to a faulty or improperly adjusted expansion valve. A flapper valve, also known as a beam valve, is frequently used in refrigeration compressor discharge valves, and is designed to pass liquid slugs. Some systems have devices installed in the compressor suction line to boil off liquid refrigerant returning to the compressor, such as liquid separators, liquid accumulators, economizers, and heat exchangers.

Compressor Principle

A compressor has two major openings (ports) through which it connects to the system by copper tubing. The inlet to the compressor is called the "Suction Line" which brings the low-pressure refrigerant vapor from the evaporator into the compressor. The other is the discharge port where the compressed refrigerant vapor, now at high pressure, is discharged into the condenser for cooling. During compression the pressure of the refrigerant increases and the volume decreases. This is explained by Boyle's law which states that at a constant temperature, a volume of gas (or vapor) is inversely proportional to the applied pressure acting on it. That is, as the pressure *increases*, the volume of gas *decreases*. Also during compression, the temperature of the refrigerant increases, the effect of a physical phenomenon known as the *heat of compression*. This is explained by Charles's law which states that at a constant volume, the temperature varies directly with the pressure i.e. as the pressure of a gas increases, so does its temperature.

TYPES OF COMPRESSORS

Compressors can be reciprocating piston, scroll, screw or centrifugal. The first three are positive displacement machines and the last is a dynamic compressor.

1) *Reciprocating compressor*

- a. Reciprocating compressors are the positive displacement machines, usually provided with two to 16 cylinders. This design minimizes their poor adaptation to large volume rates, which is one of their disadvantages.
- b. Single stage reciprocating machines have an ability to operate at compression ratios of 10 to 12.

- c. Reciprocating compressors are available in two basic types: hermetic sealed units and units of open construction. In hermetic sealed units, the motor and the compressor are direct-coupled and housed in a single casing that is sealed to the atmosphere. In open construction units, the motor and the compressor are in separate housings. In general, open construction units have a longer service life, lower maintenance requirements and higher operating efficiencies. The hermetic sealed units are most common particularly in small capacities.
- d. The capacity control in reciprocating machine is achieved through 'On-Off' or 'Loading- Unloading' of compressor cylinders.
- e. Reciprocating machines are manufactured in capacities from 0.5 to 200 TR.
- f. The main factors favoring reciprocating machine is low cost. The other advantage is that multiple reciprocating machines can be installed to closely match the building loads. Multiple units allow flexibility to operate machines per the need. If properly managed this could attribute to significant energy savings during low loads.
- g. A major drawback is a high level of maintenance requirement's, noise and vibration. Since the capacity is limited to 200TR, multiple units cost more than other options. Multiple chiller configurations require large space and consume more energy per ton of refrigeration.

2) Centrifugal Compressors

- a. Centrifugal compressors are categorized as variable volume displacement units. Like reciprocating machines these are also available in both hermetic and open construction. Commercially the hermetic sealed units are more widely used, despite its lower operating efficiency.
- b. Centrifugal compressors for refrigeration applications are generally designed for a fixed compression ratio of 18.
- c. The centrifugal compressors are manufactured in capacities from 90 to 2000 tons.
- d. The main factor favoring centrifugal machine is their high operational efficiency at full load, compact size and availability in large sizes.
- e. The biggest drawback of centrifugal machine is a very poor part load performance and inability to operate at low cooling loads. At extreme low loads, these chillers are prone to a condition known as surging.
- f. The main limitation is that these are not suitable for air-cooled condenser options and require water and cooling tower.

3) Screw Compressors

- a. Rotary or screw compressors, like reciprocating machines are positive displacement compressors. Rotary is a wider term that may include vane, eccentric, gear or screw types. The commercial refrigeration installation rely more on screw machines.
- b. Screw compressors are available in several designs, both single screw and twin screw, with oil-free and oil-injected designs in both types. Twin-screw oil-injected compressors are slightly more energy efficient at moderate compression ratios. Twin-screw compressors have an ability to operate at compression ratio of 30. Units are available in both hermetic sealed and open construction.

- c. Screw compressors are available in capacities ranging from 20 to 1000 tons and even higher from few manufacturers.
- d. Screw compressors have an ability to operate at compression ratios of as high as 30 which can be varied for optimum load adjustment.
- e. The factors favoring screw compressors is their compact size, lightweight, quite & vibration free operation and high energy efficiency both in full and part load operation.
- f. The major drawback is their high cost. For smaller loads, reciprocating machines are less expensive to purchase and for large loads centrifugal machines cost less.

4) Scroll Compressors

- a. Scroll compressors have been used in commercial practice for systems that have capacity less than 30 TR. On such small sizes, these do not affect the life cycle economics drastically.

COMPRESSOR HOUSING

The assembly compressor and drive motor are known as the compressor unit. There are three main types, depending on the way the unit is built.

1) Open systems

Open systems when the compressor and the motor are easily identifiable and the operating mode is by direct or belt drive; they present the problem that the rotating shaft may not be gastight. Open-type compressors can be used in all commercial refrigeration plants except small ones. They are particularly useful when ammonia is the refrigerant fluid.

2) Semi-hermetic or accessible units

Semi-hermetic units are those where the compressor and the drive motor are mounted in the same crankcase and hence the electric motor operates in a refrigerant atmosphere. Semi-hermetic compressors are recommended for medium-capacity installations and should operate with halocarbon refrigerants.

3) Hermetically sealed or non-accessible units

Hermetically sealed units are those where both elements are enclosed in a completely gastight steel casing, eliminating any risk of refrigerant leakage, but making any repair in the unit practically impossible. Hermetic compressor systems should be used for very small refrigerating capacities. Hermetic compressors and large semi-hermetic (above about 8 kW motor power) compressors are usually suction-gas cooled – i.e. the refrigerant cools the motor before compression. This reduces the capacity of the compressor. Externally cooled types, where the vapor passes directly into the cylinders, are usually about 8% more efficient than equivalent suction cooled models.

Open-type compressor units have several advantages over the other two types, making their installation advisable particularly in large refrigeration plants where skilled labor and maintenance personnel are employed. First, the electric motor is not in contact with the refrigerant vapor so the heat dissipated neither increases its temperature nor is it discharged by the compressor. Second, they are driven by standard electric motors which are easily replaced, and even the winding can be easily repaired. Third, the electric motor does not contaminate or affect the refrigerating circuit. Lastly, they are less sensitive to system contamination so the erection of the refrigerating circuit does not demand extreme care and skilled operators.

CAPACITY CONTROL OF COMPRESSORS

When evaluating the total heat load of a refrigerating plant the operating conditions should be such that they lead to peak refrigeration loads. This means that during lean periods, the system will not be in equilibrium and will not perform satisfactorily. To adjust the functioning of the compressor to the actual heat load, it has to operate unloaded or under a reduced capacity; this operating mode reduces compressor efficiency. Some recommendations should be followed to avoid this situation. First, it is preferable to use small compressors at full capacity rather than a large one at partial capacity. Second, especially for centralized installations, compressors must be of a satisfactory size and work at full capacity for the expected heat loads.

In spite of previous planning and precautions it may be necessary to regulate the refrigerating capacity more accurately, which implies regulating the compressor capacity. The compressor capacity must be able to cope with peak heat load and adapt itself to any operating condition. There are several ways to regulate compressor capacity.

- 1) On – Off Operation / Loading & Unloading – The reciprocating compressors are usually equipped with on-off or loading & unloading operation. The simplest is to start and stop the compressor by a control element, usually a thermostat or pressostats. This operation is conducted according to a pre-established programme and is typical for small compressors. For large compressors having multiple cylinders, one or more cylinders are put out of operation either by depressing and holding the suction valves in an open position or by discharging the cylinder into the suction line through a bypass.
- 2) Modifying the clearance volume - The volumetric efficiency of the compressor is inversely related to the clearance volume, so by increasing this volume the capacity is reduced. This control is generally employed only for screw compressors through a moveable slide stop valve, which will vary the compressor internal volume ratio to achieve optimum energy consumption during part load operation. Screw compressor capacity is also controlled by modifying the suction volume through the action of an oil-pressure circuit. This control is continuous from 100 to 10 percent, and the power requirements are proportional to the refrigeration capacity necessary in each situation.
- 3) Inlet Vane Control - The capacity control of centrifugal compressors is achieved through the use of inlet vanes on the impellers that restrict refrigerant flow.
- 4) Varying the speed - To vary the speed of the compressor by acting on the compressor drive. When an electric motor drives the compressor, two speeds are usually available so the compressor will work at full or 50 percent capacity. Alternatively, the modern compressors are equipped with variable speed drives that provide multiple loading options. However the caution is that at low rotation speed, the compressor may not be sufficiently lubricated, which is dangerous.

Compressor Efficiency Issues

The efficiency of different compressor type varies significantly, so accurate comparisons are necessary to find the most appropriate for a particular application. Some compressors need ancillaries which absorb power, such as cooling fans. These should be taken into account when making comparisons.

For applications which have large load, it is usually most efficient to split up the load between small compressors using a control system to match the total compressor capacity to the load. If the compressors are unevenly sized, the degree of capacity control is increased. More frequent starting and stopping as a result of matching the capacity of an oversized compressor to a load can erode efficiency and can reduce reliability.

The compressor capacity is affected by

- a) The compressor displacement, usually measured in m^3/s

b) The difference between the evaporating and condensing temperature – also known as the temperature lift. This is similar to the compression ratio – the pressures in the evaporator and condenser are related to the evaporating and condensing temperatures.

c) The temperature of the superheated suction vapor.

d) The properties of the refrigerant.

Operation on in-built capacity control should be avoided or minimized whenever possible. This can be achieved by:

- Avoiding the use of single, large compressor
- Selecting a combination of compressor sizes which avoids the need for operation of one or more machines on capacity control
- Where multiple compressors are used, using a control strategy which minimizes the operation of compressors on part load (in particular, does not allow two compressors to operate on 50% capacity rather than one compressor on 100% capacity).
- When refrigerating plants are operated at low temperature it is advisable and more economical to use a two-stage compression system, especially in high-capacity plants such as industrial freezers or large frozen storage chambers, despite the complexity in their installation and operation, as energy consumption is much less.
- To prevent high discharge temperatures and pressures machines with water-cooled cylinder heads or cylinder water-jacketing should be installed, particularly in warm countries and/or when compressors operate with refrigerant fluids such as ammonia that have unusually high discharge temperatures.
- Lower rotational speeds should be used to keep down the discharge temperature and to increase the reliability of the machine. The current trend is to install compressors running at 950 rpm rather than 1450 rpm. This leads to larger and costlier compressors, though maintenance and operating costs are reduced.

CONDENSERS

Condensers are heat exchangers where the refrigerant vapor is cooled and liquefied after compression. The refrigerant vapor is first cooled to its saturation temperature (dependent on the pressure of the vapor) at which point condensation begins. As it condenses to a liquid at constant temperature, latent heat is released. Only when the condensation process is finished, does the refrigerant temperature start to fall once more. This further cooling below the condensing temperature is called sub-cooling and most commonly occurs in the liquid line.

The Approach Temperature Difference (ATD)

In order to transfer heat from the refrigerant to the coolant, there must be a temperature difference between the two, and this is called the approach temperature difference (ATD). This must be large enough to provide the heat flow needed to achieve the required system capacity. However, for maximum efficiency, the ATD should be minimized, as this will reduce the temperature lift of the system. A sensible balance between these two factors has to be made to ensure adequate capacity, but at reasonable running cost and environmental impact.

The inlet temperature of the coolant is usually not controllable (for e.g. ambient air temperature or temperature of water available) but the coolant should be selected to have as low a temperature as possible. The lower the coolant temperature, for a given ATD, the more efficient the system will be. The

coolant temperature naturally rises as it cools the refrigerant-the magnitude of this temperature rise depending on the flow rate and type of coolant used. For maximum efficiency, this temperature rise should be kept low, as that means the condensing temperature can also be lower. However, the higher flow rates required would need larger fans and/or pumps, which also consume energy. As ever with refrigeration systems, a sensible balance (i.e. optimum design) must be found between conflicting requirements.

Condenser Capacity

The heat rejected by the condenser is equal to the heat absorbed by the evaporator plus the work done by the compressor. The work done by the compressor in turn depends on the design of compressor and the type of refrigerant. The coolant may be air, water or other fluids. Although water is an excellent heat transfer medium with a very high heat capacity, the choice depends on the availability and quality of the water supply.

Process heat loads can be calculated by several methods including:

For clean water: $Btuh = GPM \times 500 \times \text{temperature change}$

For other fluids: $Btuh = \text{Lbs per hour} \times \text{Specific Heat} \times \text{temperature change}$

The condenser load, or THR is this 12,000 Btuh plus the heat of compression which is derived based on the compressor type.

For semi-hermetic compressors: $\text{Full load kW} \times 3,413 \text{ Btuh per kW}$

For open drive compressors: $\text{Brake HP} \times 2,544 \text{ Btuh per HP}$

Special Note:

The actual enthalpy capacity for R-22 operating at 105°F condensing temperature and 40°F saturated suction temperature is 14,400 Btu/Ton. Correction factors must be applied for other operating conditions and refrigerants. Tower cell manufacturers have established a widely used standard of 15,000 Btu per ton. This value is not to be confused with tons of refrigeration used for chiller process load calculations which is 12,000 Btu/ton.

Example:

Cool 300 GPM of water from 60°F to 50°F with a 100 HP open drive R-22 chiller.

The process heat load is:

$300 \text{ GPM} \times 500 \times 10^\circ = 1,500,000 \text{ Btuh}$ or 125 tons of refrigeration

The condenser load is:

$(100 \text{ HP} \times 2544 \text{ Btuh/HP}) + 1,500,000 = 1,754,000 \text{ Btuh}$ or 116.9 tower cell tons

Note: Tower cells are rated at 15,000 Btuh per ton

TYPES OF CONDENSERS

Condensers can be classified into three main groups:

- 1) Water cooled (using mains, river or cooling tower water)

- 2) Evaporative –cooled (using ambient air and recirculated water)
- 3) Air cooled (using ambient air)

The first two types take advantage of the lower wet bulb ambient temperature and the greater heat transfer effect of water, and therefore operate with lower condensing temperatures. When comparing different condenser types, the power requirements of associated fans, pumps and heaters should be taken into account.

WATER COOLED CONDENSERS

Shell & Tube Type

In a shell and tube water cooled condenser, the refrigerant vapor is cooled then condensed in the shell of the unit, by cooling water flowing through the tubes. These types of condenser work at an optimum with a water velocity between 200-400 ft/min (~1 and 2 m/s), with a recommended maximum of 500 ft/min ((2.5 m/s), and with a water flow of about 3 gallons per minute per ton (or 100 liters per hour and kW of refrigeration load) when designed for 10°F drop.

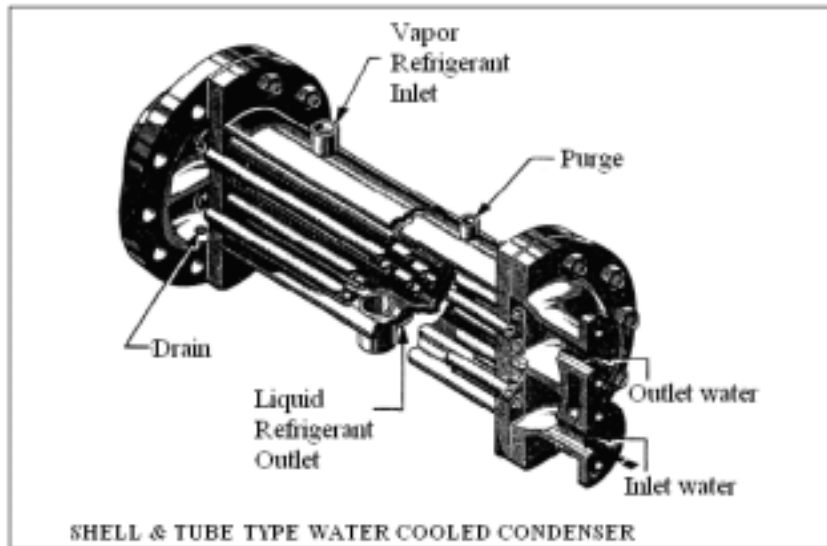

The condenser is constructed with a tube sheet brazed to each end of a shell. Copper-nickel tubes are inserted through drilled openings in the tube sheet and are expanded or rolled into the tube sheet to make a gastight seal. Headers, or water boxes, are bolted to the tube sheet to complete the waterside of the condenser. Zinc-wasting bars are installed in the water boxes to minimize electrolytic corrosion of the condenser parts.

The refrigerant condensate flows through the cylinder, the cooling water through the tubes. The end covers are divided into sections by ribs. A purge connection with a valve is at the topside of the condenser shell to allow manual release of any accumulated air in the refrigerant circuit.

The capacity of the water-cooled condenser is affected by the temperature of the water, quantity of water circulated, and the temperature of the refrigerant gas. The capacity of the condenser varies whenever the temperature difference between the refrigerant gas and the water is changed. An increased temperature difference or greater flow of water increases the capacity of the condenser. The use of colder water can cause the temperature difference to increase.

Water-cooled shell and tube condensers can work on an open-circuit or closed circuit. In open circuit, the warm water passing out of the condensers runs to waste. In a closed circuit the warm water is cooled and recycled through the condenser again.

Open circuit condenser system

Open-circuit condensers or once through system as they are typically called are used when the refrigerating plant is close to a source of abundant and suitable water. In once through system, the cooling water passes through the condenser only once. Water is simply drawn from estuary, lake or river to the heat exchanger and discharged back to the river. This system is used where large volume of cooling water is required and where the water is available in abundance. Local environment authority having jurisdiction must permit such installation as the environment issues in many states do not permit discharging hot water directly to the river because of river pollution and aquatic life concerns.

The most common type of water condenser used in an open circuit is the shell and tube condenser, but vertical multi-tubular condensers are recommended for places where the water is very hard and cleaning is often necessary because they are much easier to descale and dismantling of the condenser is not required. The main drawback is their considerable height, and they are also prone to corrosion as, besides the problem of salinity, if sea water is used, the tubes are in contact with the air.

Closed circuit condenser system

As water availability is a common problem, closed-circuit re-circulation cooling of the condenser is extensively used. The operation is based on cooling the warm water that leaves the condenser to a temperature low enough for it to be circulated again through the condenser. This cooling is achieved by giving off heat and moisture to the ambient air by a direct or indirect transfer from water to air in special devices.

Shell and tube condensers used with cooling towers and evaporative condensers are the two modes of closed-circuit operation. In the cooling tower the warm water is pumped from the condenser to the top of the tower and it cools as it falls or is sprayed down to the water basin. Cooling is achieved almost entirely by partial evaporation of the water (80 percent of cooling is latent heat removal through evaporation and 20 percent is sensible heat transmitted to the air flowing against the current).

The efficiency of cooling towers relies mainly on the wet bulb temperature of the entering air. They are not recommended in warm and humid climates but operate very satisfactorily in hot and arid zones. Cooling tower efficiency can be appraised by a coefficient called "*tower approach*", which is the difference between the average temperature of the exit water and the wet bulb temperature of the entering air. Normally the approach ranges from 3° to 6°C. Water evaporation raises the salt concentration in the circulating water. This accumulation is controlled by a purge (blowdown) which may be continuous or intermittent, and can be evaluated as about two to four times the water evaporated. Purge and evaporated water as well as water dispersed in the circulating air must be recovered by a contribution of fresh water.

The cooling water must be treated to prevent the formation of Legionella bacteria.

Evaporative Condensers

Evaporating condensers are a combination of condenser and cooling tower in a single unit. These operate on the principle that heat can be removed from condensing coils by spraying them with water or letting water drip onto them and then forcing air through the coils by a fan. This evaporation of the water cools the coils and condenses the refrigerant within. They are not recommended for warm zones with a high humidity.

The total water consumption of evaporative condensers, equivalent to the water needed to compensate evaporation, drift and purge, is about 4–5 liters per hour and kW of refrigeration load (the proportion of

evaporated water is about 35–50 percent of this quantity). Condensers of this type are considerably more difficult to clean so they should not be used with hard water.

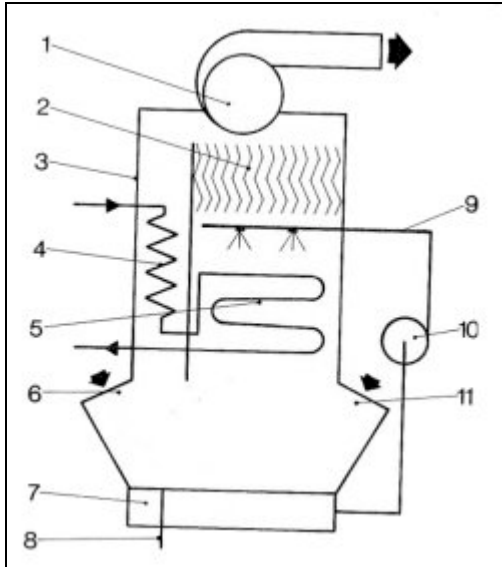

- 1. Fan
- 2. Deflector plate
- 3. Outer covering
- 4. Superheat remover
- 5. Condenser tubing
- 6. Air intake
- 7. Collecting tray
- 8. Overflow pipe
- 9. Water distribution pipe
- 10. Water circulation pump
- 11. Air intake

The big advantage of evaporative condensers over shell and tube condensers and cooling towers is that the circulating water pump is much smaller. These are used where low quality water and its disposal make the use of circulating water cooled types impractical.

AIR COOLED CONDENSERS

In an air cooled condenser, the refrigerant condenses inside finned tubes over which air is forced by fans. Since air has poor heat transfer characteristics, compared with water, a large surface on the outside of the condensing tubes is necessary. This is achieved using large ribs or fins and, in addition, by ensuring generous air circulation mechanically.

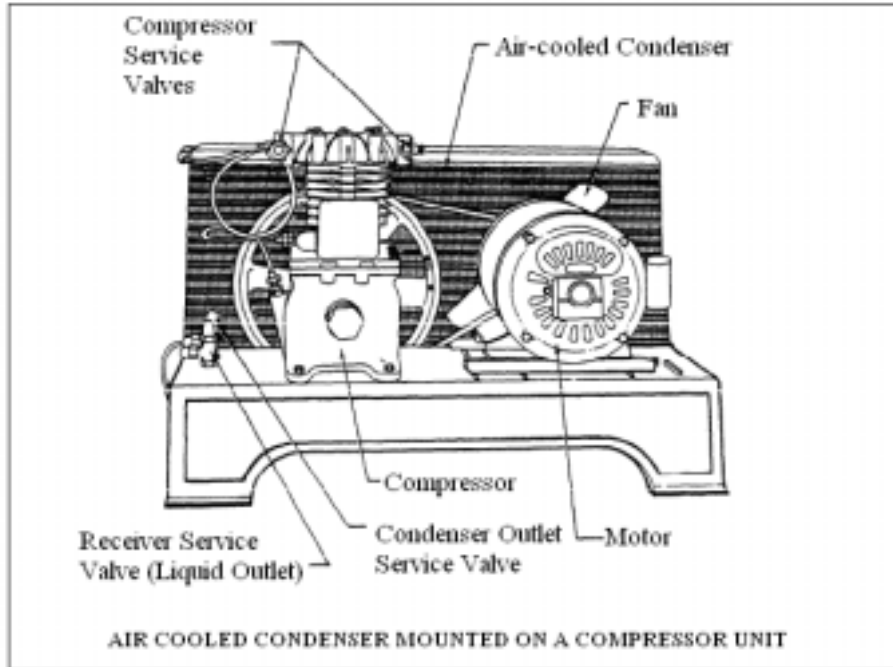

Air-cooled condensers have some advantages over water-cooled condensers.

- Water consumption is nil, which is vital where water is in short supply or not available.
- Their efficiency is indifferent to moisture content in the air, so they are appropriate for humid climates.
- They are relatively simple to install and require little maintenance because cleaning is simple and rapid.

However, they present some drawbacks, the most relevant being the high condensation temperature, which is usually 60-70°F (~15–20°C) higher than the entering air temperature. The optimum size of the condenser is computed on a condensation temperature of about 108 – 113°F (~42–45°C); in hot areas these levels will be at ambient temperature so the condensation temperature will rise up to 140 – 150°F (~60–65°C) or higher, at least in the hottest periods of the day. As the heat transfer coefficients are low large exchange surfaces are necessary, with obvious consequences in size and cost of equipment. Power consumption is another drawback, though it can be considered comparable to the consumption of cooling towers or evaporative condensers, as they are also equipped with fans and pumps.

Good air circulation is essential for satisfactory operation; therefore confined spaces must be avoided. For this reason the general trend is to mount condensers at a high level, far from the compressor, and in a cool location that is clean, dry and well ventilated, protected from the heat of the sun to prevent air recirculation and sited to take advantage of prevailing winds, particularly during periods of maximum load. They should be close to the evaporator, and whenever possible slightly above rather than below it.

Air cooled condensers are susceptible to blockage by airborne debris such as dust, feathers, packaging and so on. They must be regularly cleaned to prevent a building up of contamination, as this will reduce the air flow and hence increase the condensing pressure. The condensers should be readily accessible for cleaning and maintenance, installed on anti-vibration mountings to control noise and be safe from damage. Their efficiency depends on the cleanliness of the water or air side of the exchanger surface. Therefore periodical cleaning is necessary. Air condensers are cleaned by washing the tube bank with a hose and stopping the fans no more than once a month for a very dirty atmosphere.

The condenser should be cleaned whenever the difference in the temperatures of the condensing fluid and the water entering increases above the normal value, which is usually between 40 and 50°F (~5° and 10°C). Efficiency also depends on the condition of the exchange surface on the refrigerant side, so precautions should be taken to prevent oil accumulation. Purging non-condensable gases which may accumulate in the circuit will improve the efficiency of the condenser.

If air cooled condensers are being used in corrosive atmosphere (for example, near the sea or in polluted air) the fins are made of copper or the fin block is tinned or coated with PVC.

Condenser Safety

Condensation pressure is the parameter to control for efficient and safe operation in the high-pressure circuit. This pressure should not be excessively high, first for safety considerations and second because thermodynamically the refrigerating cycle operates less efficiently as the pressure rises, influencing energy consumption and raising operating costs.

The condenser is protected against high-pressure failure by the high pressure pressostat, a device commanding compressor cycling which cycles-off whenever the pressure rises above an established level. High-pressure controlling devices are always desirable but they are indispensable when the condenser is water-cooled. It may also be necessary to regulate the condensation pressure to avoid it becoming too low, as this does not maintain a high enough pressure differentials across the refrigerant expansion valve and the evaporator is fed with an insufficient refrigerant flow.

To maintain a high condensation pressure and corresponding high temperature, it is necessary to control the condenser capacity when the ambient temperature is low. This control is achieved either by reducing the flow of air or water circulated through the condenser or by diminishing the effective heat exchange surface area or condensing area. The condensing surface is modulated by retaining liquid refrigerant in the lower part of the condenser, using a valve known as a pressure regulator.

The water flow in a water-cooled condenser is controlled by the water pressostatic valve, activated by the condenser pressure. When the pressure is low the valve will close in relation to the decrease, reducing the flow of water circulating through the condenser. This valve may be two-way or three-way. The latter is employed to bypass the condenser in water recirculation systems. It should be located in the water inlet pipe.

For air-cooled condensers the air flow control system may cycle-off some of the fans, when there are more than one, or the air flow can be reduced with pressostatic shutters activated in the same way as the water pressostatic valve.

Condenser Selection Considerations

Water cooled condensers are typically specified when a supply of cooling water from a tower, lake, river or other source is readily available. Due to the cost of city water, water treatment, pumping costs and maintenance of a water delivery system, air cooled condensing is preferred in applications where service water is not required for other plant operations or where existing heat rejection capacity is insufficient.

Other reasons for selecting water cooled equipment are:

- 1) The refrigeration system consumes less electrical energy because the compression ratio is less. An air cooled condenser requires some potential temperature difference in order to reject heat, so the refrigeration system must operate at a higher head pressure and temperature to produce this temperature difference. Air cooled condensers normally requires between 125°F to 130°F condensing temperature to reject heat to a 100° ambient, while a water cooled condenser can operate at 105°F condensing temperature and reject its heat to a 95°F water stream. Because air is a poor conductor of heat, water cooled condensers can operate with a much lower approach temperature.

- 2) Water cooled condensers are much more compact and require no remote outdoor mounting and piping, rooftop structural preparation or outdoor NEMA-4 electrical service. Where equipment room floor space is at a premium, self contained air cooled chillers, or remote split systems are preferred.
- 3) Heat recovery is easier to obtain and control when using water cooled condenser because the heat energy is more easily transported. Heated water from the refrigeration cycle can be diverted to heat other processes and even provide space heating during winter months.

Condenser Efficiency Issues

- 1) The three type of condenser most commonly used in refrigeration all have associated level of energy consumption which must be taken into account:
 - a) Air cooled – Fan power
 - b) Water cooled – Circulating pump power and usually cooling tower components
 - c) Evaporative – Fan and pump power
- 2) The more surface area of a condenser has, the closer the condensing temperature is to the temperature of the cooling medium, whether air or water. *This lower condensing temperature shall result in lower energy consumption.*
- 3) *The condenser capacity is affected by:*
 - a) The temperature of the cooling air or water.
 - b) The size and design of the condenser.
- 4) The heat transfer of all condenser types is reduced if they are dirty:
 - a) Air cooled condenser fin blocks should be free of debris and in good condition
 - b) Water cooled condenser tubes should not be fouled, corroded or scaled up (cooling water will usually need to be treated to avoid this).
- 5) Air or other non-condensable in the system will increase the condensing temperature which results in lower efficiency. Good installation procedures (i.e. evacuation) will prevent this happening. In large systems which work with a suction pressure below atmospheric pressure, air can be drawn into the system during operation. This should be removed automatically using a refrigerated air purger (this type prevents loss of refrigerant to atmosphere when the air is removed).
- 6) The condensing pressure should be allowed to float with ambient temperature to take advantage of the lower ambient temperatures overnight and during winter. This causes the pressure ratio to vary significantly, and can cause problems with some types of commonly used expansion valve. To avoid this, more sophisticated expansion devices should be used, such as electronic or balanced port types or liquid pressure amplification should be considered

EXPANSION VALVES

Expansion valves have two functions: a) maintaining a pressure differential between the high-and low-pressure sides of the refrigerating circuit and b) metering the liquid refrigerant into the evaporator thus modulating the system capacity to meet varying demand and ensuring the refrigerant leaving the evaporator is superheated a little. This ensures that the refrigerating effect is as high as possible while still protecting the compressor from liquid refrigerant returning down the suction side.

There are four types of expansion device widely used in commercial and industrial refrigeration:

- 1) Capillary tubes
- 2) Thermostatic, electronic or balanced port expansion valves
- 3) Float valves (high and low side)
- 4) Hand expansion valve and level switch

Capillary Tube

The main purpose of the expansion device is to ensure a sufficient pressure differential between the high and low pressure sides of the plant. The simplest way of doing this is to use a capillary tube inserted between the condenser and evaporator.

A capillary is simply a length of small bore tube- its length and bore are selected to achieve the required pressure drop. It is normally used only on small factory produced systems, e.g. refrigerators, display cabinets, bottle coolers, ice-making machines, etc. These types of system usually have constant loads, and any small variations result in a reduction of system efficiency.

As a capillary tube is not capable of regulating the amount of liquid (i.e. cannot control flow), the refrigerant charge in such systems is critical in order to avoid compressor damage and to achieve maximum efficiency. System cleanliness is also very important to avoid any blockage in the capillary tube.

Thermostatic expansion valve (TXV)

The thermostatic expansion valve provides the most widely used refrigerant control because of its high efficiency and adaptability to any type of refrigeration application. This valve has the capability of controlling the refrigerant flow. Before discussing the thermostatic expansion valve, let's discuss the term "Superheat" again. A vapor gas is superheated when its temperature is higher than the boiling point corresponding to its pressure. When the boiling point begins, both the liquid and vapor are at the same temperature. But in an evaporator, as the gas vapor moves along the coils toward the suction line, the gas may absorb additional heat and its temperature rises. The difference in degrees between the saturation temperature and the increased temperature of the gas is called the superheat. A thermostatic expansion valve keeps a constant superheat in the refrigerant vapor leaving the coil. The valve controls the liquid refrigerant, so the evaporator coils maintain the correct amount of refrigerant at all times.

The amount of refrigerant needed in the coil depends, of course, on the temperature of the space being cooled. If the load on the evaporator changes the valve can respond to the change and increase or decrease the flow accordingly.

- 1) The TXV has a sensing bulb attached to the outlet of the evaporator. This bulb senses the suction line temperature and sends a signal to the TXV allowing it to adjust the flow rate. This is important because, if not all, the refrigerant in the evaporator changes state into a gas, there could be liquid refrigerant content returning to the compressor. This can be fatal to the compressor. Liquid can not be compressed and when a compressor tries to compress a liquid, mechanical failing can happen. The compressor can suffer mechanical damage in the valves and bearings. This is called "liquid slugging".
- 2) Normally TXV's are set to maintain 10 degrees of superheat. That means that the gas returning to the compressor is at least 10 degrees away from the risk of having any liquid.

The thermostatic expansion valve is fundamentally a needle valve activated by a bellows or diaphragm and a remote bulb opening on to the valve side through a capillary tube. With a few exceptions the fluid in the remote bulb is the same refrigerant as that used in the refrigerating circuit. A solenoid valve in the

high-pressure liquid line to protect the expansion valve is a compulsory element when a thermostatic expansion valve is installed and it can also serve to protect any other flow control element.

The position and installation of the remote bulb are of paramount importance for the accurate functioning of the valve. It must be firmly clamped to the suction line at the outlet of the evaporator, the groove of the bulb fitted against the side of a vertical pipe and on a horizontal pipe attached to the top at a 10 or 2 o'clock position; it should be far from any fitting or point where liquid can accumulate. The outer surface of the suction pipe must be thoroughly cleaned, removing all grease and moisture. The bulb and part of the suction pipe must be insulated, usually with rubber foam.

The amount of superheat required to bring a thermostatic expansion valve into equilibrium is fixed by adjusting the tension of the spring in the valve, called the superheat adjustment. A high degree of superheat is usually undesirable as the effective heat transfer area of the evaporator is reduced; conversely, if the superheat is set too low the valve will lose control of the refrigerant flow and the evaporator will alternatively starve and overfeed, creating very different operating conditions. The valves are usually correctly adjusted for a superheat of 40°F (~5°C). The main problem with the thermostatic expansion valve is that it cannot maintain a certain evaporator temperature and pressure; as these are influenced by the thermal load of the evaporator the refrigerant boiling temperature decreases with room temperature.

The main operating faults of thermostatic valves are the passing of too much or too little liquid. When the valve does not control liquid flow properly and it is too high, the fault is easily noticeable as the suction pipe sweats excessively and even accumulates frost, the compressor cylinder heat is cooler than normal and evaporating pressure is higher than normal. This may be due to poor valve adjustment, to wax or ice crystal deposits on the valve seat that block its closing or to the valve needle being stuck in the open position. A refrigeration engineer can easily fix these faults by readjusting the valve, cleaning it and ensuring the oil is suitable for the evaporating temperature, and replacing damaged valves. The same problem of liquid flow appears when the bulb is not secured properly to the pipe or is not correctly insulated. The bulb should be tightly refitted and/or the insulation changed.

If the evaporator pressure is lower and the compressor cylinder head is warmer than normal, the liquid refrigerant fed to the evaporator will not be sufficient. This may be due to several problems with the valve itself or with the bulb charge. The valve may be poorly adjusted; if so it must be readjusted. The inlet filter may be dirty, preventing liquid refrigerant from flowing freely through it, in which case it should be cleaned. There may be wax or ice crystal deposits preventing the valve from opening, so it must be cleaned. If the valve is stuck in the closed position it must be dismantled and repaired or discarded.

To overcome pressure drop in the refrigerant in the evaporator, which results in a considerably lower saturation temperature at the evaporator outlet than at the inlet, an externally equalized thermostatic expansion valve should be installed if the refrigerating plant is of high capacity, as evaporators produce an excessive pressure drop.

Balanced Port Valves

Balanced port valves are very similar in design and operation to the conventional thermostatic valve, apart from a special internal balanced port design. This allows the valve to control the flow of refrigerant accurately over a wide range of pressures. These valves cost approximately 20% more than a conventional valve and are available only in a limited range of sizes.

Electronic Expansion Valve

The automatic expansion valve maintains a constant pressure in the evaporator by more or less loading the evaporator surface, depending on the heat load of the cold chamber. Electronic valves work in a similar way to thermostatic valves, except that the temperature is sensed electronically and this signal is used to open and close the orifice by applying heat to a fluid (similar to thermostatic expansion valve) or

by driving a small electric actuator. This form of control is much more precise and the valve can therefore operate with a wider range of condensing and evaporating pressures. A further advantage is that they can be easily integrated into an electronic or microprocessor control system.

Float Valves

There are two main types of float valves used in refrigeration:

- 1) The low-pressure float which operates at the low side pressure
- 2) The high-pressure float, operating at the high side pressure

The high pressure float usually has the expansion valve integral within the float chamber; the low pressure float can have either an integral expansion valve or one remotely mounted in the liquid line controlled via a pilot line.

Low-pressure float valve

The low-pressure float valve is used in industrial plants to maintain a constant liquid level in the accumulator. The evaporator is therefore constantly filled to the desired level with liquid refrigerant in all conditions of heat load and independently of evaporator temperature and pressure. The vapor pressure in this flow controller and in the accumulator is the evaporation pressure.

The low-pressure float valve can operate either continuously (its throttling action modulates liquid flow into the evaporator in response to liquid level changes) or intermittently (the valve is either fully open or fully closed in response to established minimum and maximum liquid levels). A risk with this type of valve is that liquid may pass through during the compressor off-cycle. This is avoided by fitting a solenoid valve upstream of the float valve and wired in series with the compressor, shutting off the circuit when the compressor is stopped. Another drawback is faulty liquid tightness, particularly if the refrigeration circuit is not thoroughly cleaned in the mounting stage. In large-capacity systems the float valve should be installed in such a way that a bypass line equipped with a hand expansion valve permits the refrigerating plant to operate in the event of float valve failure. Two hand-stop valves, placed one each side of the float valve, allow its isolation for servicing without evacuating the large refrigerant charge from the evaporator. A low-pressure float valve can be used in parallel with a thermostatic expansion valve.

If the float valve allows too much liquid to pass through its control, evaporating pressure will be higher than normal and/or unevaporated liquid will return to the compressor, causing pipe sweating and eventually knocking. Faulty operation may be due to the valve seat not being properly cleaned, or to the ball float being punctured in which case it must be replaced (there is the risk of high-pressure liquid being trapped inside the float, so careful handling is required) or finally, the operating linkage may be jammed and must be dismantled, cleaned and lubricated.

The float valve may not allow sufficient liquid to flow, the low-pressure circuit exhibiting a lower than normal evaporating pressure and the cooling effect being noticeably reduced. This malfunction may be due to a dirty inlet filter. The operating linkage may not be moving freely and if so it must be dismantled, cleaned and lubricated. Finally the accumulator chamber may be filled with gas, either because it is not properly insulated to maintain constant temperature and pressure or because there is an obstruction in the vent pipe.

High-pressure float valve

The high-pressure float valve is similarly a liquid-activated refrigerant flow control, located on the high-pressure side of the refrigerating circuit and controlling indirectly the amount of liquid in the evaporator by maintaining a constant liquid level in the receiver. It also ensures a continuous liquid flow toward the low-

pressure circuit. The bulk of the refrigerant charge always remains in the evaporator, which is advantageous as the receiver can be small.

The operating principle of this valve is based on the perfect equilibrium of the refrigerating system as the vapor is always condensed in the condenser at the same rate that the liquid is vaporized in the evaporator. Therefore the high-pressure float valve will continuously and automatically feed the liquid back to the evaporator at the rate of vaporization and will close the circuit whenever the compressor stops.

To ensure correct feeding it is only necessary to install a single float valve for each evaporator. The surge drum for the flooded-type evaporator should have enough volume to hold the liquid. In order to avoid flooding back or slugging, a volume equal to at least 25 percent of the evaporator volume is recommended.

The refrigerant charge in the refrigerating plant is critical for this type of flow control. An overcharge will cause evaporator overfeeding, which risks liquid refrigerant flooding back to the evaporator. A more serious overcharge will impede the reduction of evaporator pressure by the compressor to the desired low level. If the system is undercharged the operation of the float valve will be erratic and the evaporator will be starved. When the refrigerant charge is seriously reduced (leaks not detected) the total amount of liquid is not enough to reach the minimum level that opens the valve and installation capacity will be nil.

The high-pressure float valve can be installed either below or above the evaporator level and it should be as close to the evaporator as possible. As it is generally placed close to the receiver the piping to the evaporator, which is very long, must have proper thermal insulation. Also, an intermediate pressure-reducing valve should be installed in the liquid line at the evaporator inlet so high pressure will be maintained in the line. This pressure-reducing valve is used in industrial systems when the thermal load is markedly constant.

The most common operating faults of high-pressure float valves are, first, too much liquid passing to the evaporator due to an overcharged system. The refrigerant must be slowly purged until correct operating conditions are restored. Second, if insufficient liquid passes to the evaporator the evaporating pressure becomes lower than normal and the cooling effect decreases. The causes are similar to those with low-pressure valves (inlet filter dirty, ball float punctured or operating linkage jammed) and can be similarly solved. The system may also be undercharged because of refrigerant fluid leakage. Leaks must be traced and repaired and the system then carefully recharged to prevent overcharging. There may be a complete loss of cooling. This is indicated also by the equilibrium of the evaporation and condensing pressure. This is caused by the valve remaining open, usually because of dirt accumulation in the valve seat or because the linkage is jammed. The valve must be repaired, though generally cleaning and lubricating are enough.

A high-pressure float valve can be used in the oil separator to assure the automatic return of the lubricating oil to the compressor crankcase.

Expansion Devices Efficiency Issues

While capillary tubes or orifice plates are used, the refrigerant quantity is critical to capacity and efficiency. If a capillary tube is damaged or partially blocked it will not control the system correctly and the efficiency will reduce.

With thermostatic expansion valves the superheat setting has a significant effect on efficiency and reliability:

- If the superheat is too low, liquid refrigerant may return to the compressor, causing damage or failure
- If the superheat is too high (usually above 5 deg K), capacity and efficiency are unnecessarily reduced.

Thermostatic expansion valves do not control well over widely varying pressure differences so, to take advantage of floating head pressure, balanced port or electronic valves should be used.

The high pressure float has one advantage over all the other types of expansion device because it is fitted with a vent tube so that when the plant stops, the pressure differential across the valve equalizes. Thus, on start-up, the compressor drive motor absorbs less power than during a normal start-up.

REFRIGERANTS

A refrigerant is the primary working fluid used for absorbing and transmitting heat in a refrigeration system. All substances that exist in liquid and vapor states absorb heat during evaporation and could therefore be used as refrigerants. Water, for instance, could even be used, but its boiling point is too high to be of practical use. A refrigerant should evaporate at the required cooling temperature at a reasonable pressure, and must be able to be condensed by a readily available cooling medium (usually ambient air) at a practical pressure.

Refrigerants used in refrigeration and air-conditioning are usually one of:

- 1) CFC – chlorofluorocarbons
- 2) HCFCs – hydro chlorofluorocarbons
- 3) HFCs- hydro fluorocarbons
- 4) HCs – hydrocarbons
- 5) NH₃ – ammonia

CFCs deplete stratospheric zone and following the Montreal Protocol, are no longer produced. They were very widely used in the past, and are therefore still in older systems. HCFCs also deplete ozone, but to a lesser extent HFCs have zero ozone depletion potential.

Ammonia NH₃ is used extensively in large industrial refrigeration plant. Ammonia has a characteristic smell even in small concentrations in air. It cannot burn, but is explosive when mixed with air in a volume percentage 13-28. Because of corrosion, copper or copper alloys must not be used in ammonia plant.

Refrigerant Properties

The temperatures of the refrigerant in the evaporator and condenser are the temperatures of the cold and warm regions, respectively, with which the system interacts thermally. This, in turn, determines the operating pressures in the evaporator and condenser. Consequently, the selection of a refrigerant is based partly on the suitability of its pressure-temperature relationship in the range of the particular application. It is generally desirable to avoid excessively low pressures in the evaporator and excessively high pressures in the condenser. Other considerations in refrigerant selection include chemical stability, toxicity, corrosiveness, and cost. The type of compressor used also affects the choice of refrigerant. Centrifugal compressors are best suited for low evaporator pressures and refrigerants with large specific volumes at low pressure. Reciprocating compressors perform better over large pressure ranges and are better able to handle low specific volume refrigerants. Other considerations in refrigerant selection include chemical stability, toxicity, corrosiveness, and cost.

How to Choose a Refrigerant

The type of refrigerants used varies according to what the application is and what the requirements are. Many factors need to be considered

1) Ozone depletion potential

- Chlorinated and brominated refrigerants
- Acts as a catalyst to destroy ozone molecules
- Reduces the natural shielding effect from incoming ultra violet B radiation

2) Global warming potential

- Gases that absorb infrared energy
- Gases with a high number of carbon-fluorine bonds
- Generally have a long atmospheric lifetime

3) Combustibility

All hydro-carbon fuels, such as propane

4) Thermal factors

- The heat of vaporization of the refrigerant should be high. The higher the heat of vaporization, the greater the refrigerating effect per *kg* of fluid circulated
- The specific heat of the refrigerant should be low. The lower the specific heat, the less heat it will pick up for a given change in temperature during the throttling or in flow through the piping, and consequently the greater the refrigerating effect per *kg* of refrigerant
- The specific volume of the refrigerant should be low to minimize the work required per *kg* of refrigerant circulated since evaporation and condenser temperatures are fixed by the temperatures of the surroundings -selection is based on operating pressures in the evaporator and the condenser
- Selection is based on the suitability of the pressure-temperature relationship of the refrigerant

5) Other factors include:

- The refrigerant ought not to be poisonous. Where this is impossible, the refrigerant must have a characteristic smell or must contain a tracer so that leakage can quickly be observed.
- The refrigerant ought not to be flammable or explosive. Where this condition cannot be met the same precautions as in the first point must be observed.
- The refrigerant ought to have reasonable pressure, preferably a little higher than atmospheric pressure at the temperatures required to be held in the evaporator (otherwise prone to air leakage).
- To avoid heavy refrigerator design, the pressure which corresponds to normal condensing pressure must not be too high (otherwise prone to refrigerant leakage).
- Relatively high evaporating heat is required so that heat transmission can occur with least possible circulating refrigerant.

- Refrigerant vapor ought not to have too high a specific volume because this is a determinant for compressor stroke at a particular cold yield.
- The refrigerant must be chemically stable at the temperatures and pressures normal in a refrigeration plant.
- The refrigerant ought not to be corrosive and must not, either in liquid or vapor form, attack normal design materials.
- The refrigerant must not break down lubricating oil. The refrigerant must be easy to obtain and handle.
- The refrigerant must not cost too much.

Types of Refrigerants

A refrigerant can either be a single chemical compound or a mixture (blend) of multiple compounds.

- 1) **Azeotropic** - These are blends of multiple components of volatilities (refrigerants) that evaporate and condense as a single substance and do not change their volumetric composition or saturation temperature when they evaporate or condense at a constant pressure. The word "azeotropic" means that the refrigerant will be found in the same concentration over the whole plant. Components in a mixture of azeotropes cannot be separated from their constituents by distillation. Properties of azeotropic refrigerants are entirely different from those of their components and may be conveniently treated as a single chemical compound. R 502: An azeotropic mixture of refrigerants R 22 and R 115 (CClF₂CF₃).
- 2) **Near Azeotropic** - Near-azeotropic refrigerants are blends whose characteristics are near to azeotropic. Although properties of near-azeotropic refrigerants are nearer to azeotropic than to non-azeotropic (zeotropic), near-azeotropic refrigerants are defined as zeotropic or nonazeotropic.
- 3) **Zeotropic** - These are blends of multiple components of volatilities (refrigerants) that evaporate and condense as a single substance and do change volumetric composition or saturation temperature when they evaporate or condense at a constant pressure. It is recommended to check with the manufacturers of the refrigerant before using a zeotropic blend in a flooded evaporator system as it may affect the system's performance.
- 4) **Blends** - Mixtures of refrigerants of two or more chemical compounds are blends. The advantage of a blend of multiple chemical compounds compared to a single compound is that the required properties of the blend can possibly be achieved by varying the fractional composition of the components.
- 5) **Glide** - Zeotropic mixtures, including near-azeotropic blends, show changes in composition because of the leaks, the difference between liquid and vapor phases, or the difference between the charge and circulation, or their combined effect. The shift in composition causes the change in evaporating and condensing temperature and pressure. The difference in dew point and bubble point in the temperature-concentration diagram of a zeotropic refrigerant during evaporation and condensation is called *glide*, expressed in °F (°C). A near-azeotropic refrigerant has a smaller glide than a zeotropic one. The midpoint between the dew point and bubble point is usually taken as the evaporating or condensing temperature for a non-azeotropic and near-azeotropic refrigerant.

Secondary refrigerants

The refrigerants mentioned above are often designated "primary refrigerants". In large refrigeration systems, secondary fluid is cooled by the primary refrigerant for carrying refrigeration from the plant room to the space where it is usefully applied.

Secondary fluid such as water, brines, glycols and sometimes even halocarbons are used in many applications, often to reduce the amount of toxic, flammable or environmentally-damaging primary refrigerant used, or to prevent product contamination by the primary refrigerant in the event of a leak. The desirable properties of the secondary coolants are low freezing point, low viscosity, non inflammability; good stability and low vapor pressure. Chilled water is used as a secondary refrigerant in air-conditioning applications. For low-temperature applications, brines, glycols and hydrocarbons are used.

Most secondary refrigerants absorb sensible heat i.e. change temperature, as they cool the product. Some, however, absorb latent heat by changing the liquid to gas, or solid to liquid, and so have a higher capacity per unit mass flow. The temperature of the secondary refrigerant may, therefore, not change and so the temperature difference is maintained for good heat flow. Secondary refrigerants using latent heat include carbon-dioxide and slurry-ice.

Refrigerant leakage

Refrigerants should be selected to suit the evaporating temperature in such a way that the pressure at any point of the circuit is always above atmospheric pressure. In this way any refrigerant leakage will be outward.

With halocarbon refrigerants there is a high rate of leakage that can be detected by the presence of oil on the outside, as oil escapes with the refrigerant. For more direct detection a halide lamp or an electronic type detector can be used. In the absence of detecting equipment the area suspected of leakage can be tested by brushing a soap and water solution over it. The halide lamp flame reveals the presence of refrigerant by turning light green when the refrigerant is drawn into the search tube. As halocarbons are heavier than air, leaks should be looked for mainly on the underside of the joints, moving the sensor slowly and avoiding draughts. The electronic type detector works on the difference in electric resistance between air and refrigerant and indicates the presence of refrigerant with a visual alarm. It is very sensitive and will detect very small refrigerant concentrations.

Ammonia leaks are detected by passing burning sulphur candles around the suspected joints. The presence of ammonia will be indicated by a dense white smoke. Although ammonia is a flammable refrigerant this method of detection does not represent any danger provided the ammonia concentration is low.

Majority of building codes recommend that the refrigeration machine room must be provided with refrigerant leak detectors (particularly for ammonia) so that the alarm systems are activated and the plant shut down is initiated in case of leakage. Extractor fans, water spray points and carbon dioxide fire extinguishers are required in the event of ammonia leakage. These elements should be independent of the general electric mains and be readily accessible outside the machine room.

Non-condensable gases

Non-condensable gases accumulating in the high-pressure side of the refrigerant circuit will cause a rise in delivery pressure, affecting compressor power consumption and wear.

The presence of these gases in the system is indicated by the standing head pressure shown on the delivery gauge once the system is stabilized, that is when the condenser is in thermal equilibrium with the environment. If this pressure is greater than that of the refrigerant vapor that corresponds to the equilibrium temperature, then non-condensable gases are present in the condenser. These must be removed from the system step by step by purging from the highest point on the high-pressure side, slowly reducing the pressure and allowing stabilization by short intervals after each reduction. Automatic purgers are usually installed in industrial refrigerating plants for continuous non-condensable gas removal.

Refrigerant Efficiency Issues

- 1) The type of refrigerant can affect the efficiency of a system by up to 10%.
- 2) The relative performance and efficiency of a refrigerant is affected by the type of compressor and the operating conditions.
- 3) Zeotropic blends can give advantages in capacity and efficiency when used in the correct way (i.e. advantage is taken of temperature glide in the evaporator).
- 4) The amount of charge is important-too much and especially too little refrigerant can reduce efficiency.
- 5) It is important that systems do not leak refrigerant- insufficient refrigerant reduces evaporator wetted surface area and results in increase superheat. This reduces the suction pressure and increases the temperature lift, thus reducing efficiency.
- 6) If refrigerant is contaminated, example with air, the efficiency of the system is reduced.

ACCESSORY DEVICES

The four basic or major components of a refrigeration system (as discussed above) are not the only items that would constitute a large commercial or industrial vapor compression refrigeration system. Additional devices and controls are needed for a smoother and more controlled cycle. Let's take a close look at schematic diagram below that shows many other devices.

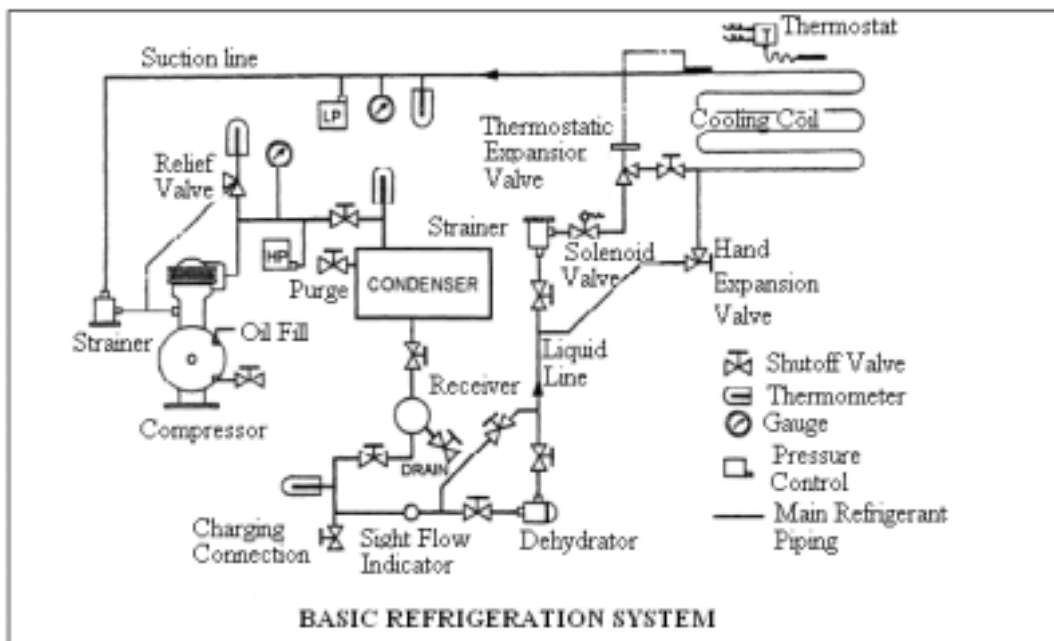

Controls

Refrigeration systems are usually controlled either by a thermostat in the cooled space or secondary refrigerant, or by the suction pressure. It is important that these controls do not allow the system to operate at a lower evaporating temperature than necessary (thus increasing the temperature lift and the duration of operation).

There will also be safety devices on most systems. These can include:

- 1) A high pressure switch connected to the compressor discharge which will switch off the system, if the high pressure exceeds the setting (i.e. a safe level)
- 2) A pressure relief device on the receiver which will open and allow the refrigerant to escape, if the pressure exceeds the setting (i.e. before it builds up to a dangerously high level)

Some systems may have a control (often another high pressure switch) to regulate the condensing pressure and maintain it at a high level regardless of ambient temperature. This forces the system to always operate at a high temperature lift, thus reducing system efficiency.

A low pressure switch is used on many systems to control the pump down system and shut off the compressor when the application is down to temperature. A solenoid valve in the liquid line closes when the system has achieved the desired setting of the low pressure switch- the compressor then stops with the liquid refrigerant safely contained in the high side of the system. In this way there is no possibility of liquid refrigerant flooding into the compressor and causing damage.

Thermostats

Thermostats are temperature-activated controllers that regulate the temperature level of a refrigerated space by cycling the compressor on and off. They consist of a sensing element and an electric contactor. Three types of temperature-sensing elements are commonly used in refrigeration: fluid filled bulbs connected to pressure bellows or diaphragm, bimetal strips or compound bars, and electric resistances and semiconductors. The latter two are seldom used in refrigeration, but as they are rather easy to install and regulate they promise well for the future. Thermocouples as sensing elements in the thermostats are rarely used in refrigeration.

A problem with the pressure bellows type of element is they may lose their fluid charge. To check these compress the bellows by hand. If they move under finger pressure the fluid charge has been completely or partially lost. The bellows assembly must be replaced, if accessible, otherwise the thermostat must be changed.

Electric failure of the thermostats may be due to poor electrical connections (clean and tighten them for correct operation) or to worn, pitted or corroded contact points (replace them). These mechanical or electrical failures will cause the thermostat to remain either open or closed. When it stays open the compressor will shut down even if the room temperature is above the desired level. The use of a jumper lead across the terminals should immediately restart the compressor.

When the thermostat remains closed, the compressor will continue running even if the room temperature is below the established level.

Faulty operation may also be traced to the incorrect installation of the sensing element, usually the fluid bulb. If it is not securely attached to the evaporator surface and/or it is not sufficiently clean and dry for good thermal contact, an excessive temperature difference is necessary before the thermostat operates.

When the thermostat directly controls space temperature the bulb is fixed to the chamber wall with a metallic bracket in one of the positions already described. If there is no thermal insulation between the bulb and the bracket the equilibrium temperature of the bulb will be higher than that of the room space.

High-Pressure Safety Switch

High-pressure safety cut-out switch is activated when the pressure in the condenser is too high, protecting the system against overload and rupture of the piping. The pressure switch is fitted to the compressor discharge line and wired in series with the compressor drive, which is cycled-off whenever an increase in condensation pressure becomes excessive.

High condensation pressure can be caused by any of the following:

- 1) Faulty cooling of the condenser, which may be because of a) the failure of pumps in water-cooled condensers or of fans in air-cooled condensers; b) failure of the water circuit which does not circulate sufficient water or c) because the water temperature and the equivalent air temperature are too high; and finally d) fouling of the condenser surface (scale, algae and dust in air-cooled condensers).
- 2) The heat exchange surface area is reduced by refrigerant liquid accumulation in the lower part of the condenser. This may be the result of an excessive refrigerant fluid charge in the system or irregular operation of the pressure control.
- 3) Non-condensable gases present in the circuit, particularly with ammonia installations. In this case a purge is necessary.
- 4) The automatic control of the condensation pressure is adjusted to an unusually high level.
- 5) A fire on the premises, producing a quick rise in circuit pressure.

Note that the pressure safety cut-out switch is not enough to protect the refrigeration plant and some other device such as a safety pressure relief valve, a fusible plug, a rupture disk or a fuse are necessary. Whenever high-pressure vapor breaks out it must be evacuated from the environment without any risk to personnel or people in the machine room or surrounding areas. Sometimes the high pressure is released into the low pressure circuit, which should be provided with a leakage restrictor. A high pressure switch must always be fitted when water-cooled condensers are used, and the connection must be taken from a point in the discharge line where it cannot be inadvertently isolated.

The cut-out pressure should be set well above the maximum condensing pressure when the plant is operating at full load. The pressure differential should be established according to the operation and bearing in mind that a small differential will result in compressor short-cycling that may cause electrical damage, while large differentials will result in too long off-cycles, leading to an abnormally high rise in storage temperature.

Low-Pressure Safety Switch

The low-pressure safety switch operates when the pressure in the suction circuit decreases below a set level, with the risk of air entry into the circuit if it drops lower than atmospheric pressure. The most common risk is that of very low evaporation temperatures with possible damage to the stored produce and/or the refrigeration plant.

Low-pressure safety cut-out break the circuit to the compressor motor when evaporating pressure falls. There are several causes for low evaporating pressures.

- 1) The evaporator is not correctly fed or is not fed at all. This may be owing to the blockage of the expansion valve or its filter, or the solenoid valve upstream of the expansion valve is not in operation, generally because the coil is out of order and thus the automatic valve operated by the solenoid valve is not working.
- 2) Compressor capacity clearly exceeds evaporator capacity. This may be because of malfunctioning of the compressor capacity control device; the evaporator fans may have stopped accidentally, reducing heat exchange; there may be excessive frost deposit on the evaporator leading to the same heat exchange problem; or the constant pressure valve regulating the evaporating temperature may not be properly adjusted. If there is a very small difference between room and evaporator temperatures the suction pressure may be too low.

- 3) The refrigerant fluid charge in the circuit is too small, which may be because of an installation error or a small leakage difficult to discover.
- 4) Sudden and unusual oil dragging into the low-pressure circuit, which both diminishes heat exchange and increases pressure loss in the suction line.
- 5) The thermostat is blocked in an open position, keeping the compressor in operation while the thermal load of the evaporator decreases continually.

The low pressure switch must be set to cut-out at a pressure well below the lowest normal evaporating pressure when the evaporator is working at minimum load, but above a certain pressure to avoid freezing or cold damage to the produce.

Small differentials will result in compressor short-cycling so they must be avoided to prevent equipment damage. On the other hand large differentials will result in long off-cycles.

Delivery Thermostat

This safety device is used only for ammonia machines as there is the risk of increase in compressor delivery temperature above 130°C. This temperature is dangerous as the lubricating oil may break down, notwithstanding high temperature decomposition, and form corrosive acids and sludges. There are several causes for an excessively high delivery temperature.

- 1) The system is operating under an excessive compression ratio (absolute discharge pressure divided by absolute suction pressure) especially when it is linked to a refrigerant fluid with a high polytropic compression exponent, for instance ammonia.
- 2) The suction pressure is very low because the constant pressure valve is not correctly regulated. The lower the suction pressure the higher the discharge temperature, other circumstances remaining constant. Again the two-stage compression systems offer an advantage, as they avoid high discharge temperature.
- 3) Suction superheat is excessively high due to poor insulation of the suction pipe and/or because it is too long. In ammonia refrigerant system an automatic humidifier is an advantage where the vaporization of partly vaporized liquid ammonia injected in the suction line from the liquid receiver provides the necessary de-superheating of the vapor.

The delivery superheat thermostat cycles-off the compressor if the discharge temperature is too high. When in operation it avoids serious risk to the compressor, so it must be manually reset.

Thermostatic Switch

Occasionally, a thermostat in the refrigerated space operates a solenoid stop valve, and the compressor motor is controlled independently by a low-pressure switch. The solenoid control switch, or thermostat, makes and breaks the electrical circuit, thereby controlling the liquid refrigerant to the expansion valve. The control bulb is charged with a refrigerant so that temperature changes of the bulb itself produce like changes in pressure within the control bulb. These pressure changes are transmitted through the tubing to the switch power element to operate the switch. The switch opens the contacts and thus releases the solenoid valve, stopping the flow of refrigerant to the cooling coil when the temperature of the refrigerated space has reached the desired point. The compressor continues to operate until it has evacuated the evaporator.

Relief Valve

A refrigeration system is a sealed system in which pressures vary. Excessive pressures can cause a component of the system to explode. A spring-loaded relief valve is most often used and it is installed in the compressor discharge line between the compressor discharge connection and the discharge line stop valve to protect the high-pressure side of the system. No valves can be installed between the compressor and the relief valve. The discharge from the relief valve is led to the compressor suction line.

Discharge Pressure Gauge and Thermometer

A discharge pressure gauge and thermometer are installed in the compressor discharge line (liquid line) to show the pressure and temperature of the compressed refrigerant gas. The temperature indicated on the gauge is always higher than that corresponding to the pressure when the compressor is operating.

Oil Separation Systems

Refrigeration compressors pump a small amount of oil with the refrigerant. The installation should be designed to ensure that this oil circulates around the system and returns to the compressor. Oil logging in components such as evaporators can significantly reduce their efficiency and a shortage of oil in compressor will decrease its reliability and eventually result in a mechanical failure.

Some refrigerants do not carry oil around the system reliably, so it is necessary when using these refrigerants (or when there are significant variations in the system load) to install an oil separator in the discharge line just after the compressor. The oil separator will remove the majority of the oil from the discharge vapor and return to the compressor's crankcase.

Where compressors have been installed in parallel (e.g. to meet a large load) an oil management system is required to ensure that oil is returned only to the compressor that need it- failures and loss of efficiency can occur if a compressor's crankcase is overfilled with oil as well as if there is too little. Each compressor is filled with a valve which senses the crankcase oil level. As the level drops so the level opens, allowing a flow of oil from the reservoir to enter the crankcase to maintain the optimum level.

Oil Pressure Control

This control is used when the compressor is provided with pump lubrication. If the compressor is splash lubricated there is usually no control device to protect it against lubrication failure, but some machines are equipped with an oil level contactor which cycles-off the compressor motor when the oil level inside the crankcase is below minimum.

Faulty lubrication of the compressor can be caused by either of the following.

- 1) Not enough lubricating oil in the compressor crankcase. This may be because of error in the quantity of oil charge to the circuit, especially when halocarbon refrigerants are used; entrapment of oil in the circuit, which does not return at a proper rate to the crankcase; some oil leaks are present and the oil purge from the oil and liquid separators is not correctly conducted.
- 2) The oil pump is accidentally out of order, probably because of breakdown. The suction and/or delivery oil pipes are obstructed and the pressure of the pump is not enough to overcome this.

The oil-pressure control stops the compressor when the useful pressure developed by the pump falls below a fixed minimum or the oil pressure does not rise to the minimum safety level within an established period. Useful pressure is the difference between total pressure and suction pressure. Therefore the oil-pressure switch, which is activated by useful pressure, must be connected by two pressure bellows to the crankcase and the oil pump discharge.

A time delay relay is incorporated in the oil-pressure control to allow the compressor an operating period of about 30–120 seconds with oil pressure below safety level. If the control starts operating as a result of

malfunction in the compressor lubricating system, a lamp and/or a hooter (visible-audible alarm) will be activated. The latter can be manually disconnected. After failure and before the compressor can be restarted the oil-pressure control must be manually reset because of the high risk involved in its operation.

The compressor manufacturer's instructions usually set the cut-in and cutout pressures for the oil-pressure control.

Solenoid Valves

Solenoid Stop Valves, or magnetic stop valves, control gas or liquid flow. They are most commonly used to control liquid refrigerant to the expansion valve but are used throughout the system. When gas defrosting is used solenoid valves are fitted in the refrigeration circuit to reverse refrigerant flow.

A solenoid valve is simply an electrically operated valve consisting of an electromagnetic coil which when energized draws a plunger which opens the valve port. Closing action is achieved by gravity when the coil is de-energized. Solenoid valves controlling the refrigerant flow in the liquid line feeding the evaporators are thermostatically activated.

Solenoids vary according to a) permitted pressure differences across the valve; b) drop in pressure through the valve; c) the desired flow rate and d) the state of the circulating fluid. The valves can be direct acting or pilot operated. Small solenoid valves are usually direct acting; they are fitted in small diameter pipes and their power demand is low, about 15 Watts. Pilot-operated solenoid valves are used in large-diameter pipes as the pressure differences across the valve provide the force to carry out the closing and opening actions.

Solenoid valves are simple and robust, and their functioning is generally reliable and accurate as they usually operate in an on-off mode. This is also true when they work in a modulated fashion (applying a changeable voltage to the electromagnetic coil of the valve).

They have some drawbacks. They are not gastight, particularly for large pipe sections. Their most usual failure is coil breakdown, which is not foreseeable so it is impossible to detect during maintenance operations. Unless they are vapor-tight condensation of water vapor on their cold side may occur, particularly when they are installed in rooms with high humidity and working in medium-temperature conditions. There is also some risk of causing a "water hammer" effect in the liquid line.

Solenoid valves must be correctly installed. They must always be mounted in a vertical position with the coil on top, unless they are specially designed for horizontal installation. They must also be mounted in line with the direction of flow, usually shown by an arrow on the valve body.

Insulation

Insulation is important in reducing heat loads on a refrigeration system. In particular it will be used to:

- 1) Reduce heat gains into cooled spaces such as cold stores and cabinets
- 2) Reduce the heat gain into the suction vapor between the evaporator and the compressor

Heat Recovery

The condensing refrigerant in a refrigeration system is warmer than ambient temperature. The amount of heat rejected in the condenser is the cooling effect plus most of the compressor input power. Heat can be recovered from:

- 1) The discharge vapor, which can be as hot as 150°C. The heat is removed in a de-superheating vessel between the compressor and condenser. The amount of heat available is however relatively small.

- 2) The condenser, which is normally 10 to 30°C above ambient temperature.
- 3) The oil used on oil cooled compressors, which can be between 60 and 80°C.

It is essentially that the effect of heat recovery on the performance of the refrigeration system is carefully analyzed. In many cases, recovering useful heat from the condenser forces the system to operate less efficiently (i.e. at a higher condensing temperature), and the savings in heating costs are usually less than the added refrigeration costs.

A de-superheater recovers high temperature heat from the discharge vapor leaving the compressor. The discharge temperature depends on the operating conditions of the system and the refrigerant. R22 and ammonia operate with significantly higher discharge temperatures than most other refrigerants.

In a well designed refrigeration system the condensing temperature should be as low as possible. Any heat recovered from the condenser will be a very low temperature is very rarely useful.

In oil-flooded screw compressors much of the motor heat is dissipated into the lubricating oil. The oil usually enters the compressor at about 40°C and leaves it at 60 to 80°C. For an R22 system, about 38% of the motor power would be absorbed by the oil and consequently be available for recovery. For ammonia systems this figure increases to about 60%.

Liquid Receiver/Accumulator

Liquid refrigerant must never be allowed to enter the compressor. Liquids are non-compressible; in other words, their volume remains the same when compressed. An accumulator is a small tank accessory; that is, a safety device designed to prevent liquid refrigerant from flowing into the suction line and into the compressor. A typical accumulator has an outlet at the top. Any liquid refrigerant that flows into the accumulator is evaporated, and then the vapor will flow into the suction line to the compressor.

Large commercial or industrial refrigeration systems may have multiple expansion valves and multiple evaporators in order to refrigerate multiple enclosed spaces or rooms. In such systems, the condensed liquid refrigerant may be routed into a horizontal pressure vessel, usually called an "accumulator", from which liquid refrigerant is withdrawn and routed through multiple pipelines to the multiple expansion valves and evaporators. In general the accumulator

- 1) Hold a buffer of refrigerant to ensure there is always liquid available if the load on the evaporator changes
- 2) Hold all the refrigerant charge safely during a pump down operation

Liquid Line

The refrigerant accumulated in the bottom of the receiver shell is conveyed to the cooling coils through the main refrigerant liquid line. A stop valve and thermometer are usually installed in this line next to the receiver. Where the sight-flow indicator, dehydrator, or filter-drier is close to the receiver, the built-in shutoff valves may be used instead of a separate shutoff valve.

Liquid Line Filter-Drier or Dehydrator

It is critical to the efficient and reliable operation of any refrigeration system that the refrigerant is kept free from moisture and particles. Moisture can freeze at the expansion device, restricting or completely blocking the flow of refrigerant. Small particles can have a similar effect and can damage the internal working parts of valves and compressors. To prevent this happening, a filter drier is installed in the liquid line. These are fitted with a fine mesh filter and are filled with a desiccant to absorb moisture. Some filter-

driers are equipped with a sight-glass indicator. A dehydrator is similar to a filter-drier, except that it mainly removes moisture.

Distributor

A distributor is used to ensure refrigerant flows evenly between the different parallel circuits of a direct expansion (DX) evaporator coil. Saturated refrigerant is fed through the distributor into the evaporator tubes where it is totally evaporated before reaching the outlet. It is important that the outlet tubes from the distributor connect to the evaporator tubes in equal length for pressure equalization, otherwise partial defrosting will occur at some portion of the evaporator coil.

Sight Glass

A sight glass is fitted in the liquid line of all but small commercial systems. It gives a visual indication that the refrigerant in this line is liquid. It is used;

- 1) To gauge the correct charge during installation
- 2) To check that the system is fully charged during operation and maintenance (although vapor bubbles in the sight glass also occur if the filter drier in the liquid line is blocked)

A shortage of refrigerant, e.g. due to a leak, significantly reduces the system efficiency. More sight glasses also incorporate a visual indicator which responds to the dryness of the refrigerant. Any moisture present will change the color of the indicator.

Pipework

Copper or steel pipework is used to join the system components to make a complete circuit. The pipework is designed and installed to:

- 1) Minimize pressure drops, thus keeping the compressor compression ratio as low as possible to maintain efficiency
- 2) Allow oil to return to the compressor by ensuring the refrigerant's velocity is sufficiently high.
- 3) Both the pipe sizing and its routing will have an impact on these requirements.

Liquid Pressure Amplifier (Liquid line pump)

Liquid pressure amplification (LPA) is used to increase effectively the level of sub-cooling at the expansion valve and reduce the amount of work needed by the compressor. This is achieved by using a liquid pump between the receiver outlet and the expansion valve. The pump raises the pressure of the liquid into the expansion valve, so the valve will control well even when the head pressure floats down with falling ambient temperature. Significant energy savings and improvements in reliability have been reported by users of LPA system.

Spares

A stock of spare parts should be kept, giving priority to those that are the most frequent causes of trouble. The list will be related to ease of supply. In some cases duplicates for control apparatus should be stocked, but in general the following elements will suffice: lubricating oil and refrigerant fluid; coils for each type of solenoid valve and a solenoid valve of each type; sets of valves (especially suction valves) and piston rings for each type of compressor; sets of joints and driving belts; fan motors for air coolers; and fuses, coils for electrical contactors, cut-outs, etc.

Automation

Automation of a refrigerating installation should satisfy two major objectives: 1) it should provide a more accurate control and assure controlled parameters (temperature or relative humidity in the chamber for instance) do not differ from the fixed values and that they can be readjusted when they are not within the established range; 2) it also serves another function of paramount importance - safety.

Control may be more or less extensive depending on whether automation is partial or integral. There are certain situations, in large and complex installations for instance, where semi-automation may be recommended, partly for economic reasons but also for safety as these installations must not be allowed to operate without human supervision. The essential feature of a semi-automatic refrigerating plant is that the choice of the operating periods is left to the operators' initiative. Once the plant is in service, control is automatic as in totally automatic plants.

Automatic control must include the communication of information to allow supervision of the plant's operation. All the sensing elements should be linked to indicator lights, measuring devices, audio warning devices, and so on, which are displayed in the machine room. They are generally incorporated in a synoptic luminous panel. There must also be remote control of the machinery in the machine room, either for manual control of the operation or for resetting the control elements after operation failure. Automatic equipment should be verified at least once a week with reliable apparatus.

The automatic sequence of machine start-up should be established with these requirements in mind:

- 1) The compressor must not run if the condenser cooling water pump or the condenser fans are not working
- 2) The refrigerant liquid pump will not work until the compressor and evaporator fan are running and the refrigerant fluid is circulating in any of the evaporators
- 3) When the refrigerant fluid is not circulating in the evaporators, the various elements of the refrigerating circuit should be stopped.

In modern plants, automation is widespread and even in manually operated plants some automatic apparatus is installed for accurate and continuous monitoring of certain operations.

BASIC THERMODYNAMICS

Thermodynamics is a branch of physics which deals with the energy and work of a system.

Thermodynamic Cycle

Thermodynamic cycle is defined as a process in which a working fluid undergoes a series of state changes and finally returns to its initial state. A cycle plotted on any diagram of properties forms a closed curve.

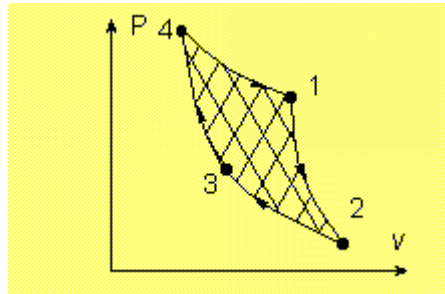

A reversible cycle consists only of reversible processes. The area enclosed by the curve plotted for a reversible cycle on a p-v diagram represents the net work of the cycle.

- 1) The work is done on the system, if the state changes happen in an anticlockwise manner.
- 2) The work is done by the system, if the state changes happen in a clockwise manner

There are certain fundamental principles of nature, often called laws of thermodynamics, which govern our existence here on Earth, several of which are basic in the study of refrigeration. The first and most important of these laws is the fact that energy can neither be created nor destroyed, but can be converted from one type to another.

The first law of thermodynamics states that energy is conserved. We may express it as follows: Increase in internal energy of a system is equal to heat put into the system with the deduction of work done by the system on its surroundings, or

$$\Delta U = \Delta Q - \Delta W, \text{ where}$$

- U – internal energy
- Q – heat
- W – work

A system can be anything. It is most convenient, if it has well defined boundaries. ΔQ is positive, if it is put into the system and negative if it is taken out of the system. ΔW is positive if the system does work on its surroundings and is negative if work is done on the system. The internal energy is the sum of the kinetic and potential energies of atoms and molecules that make up the system.

The second law of thermodynamics

Sadi Carnot (1796 -1832), Rudolf Clausius (1822-1888), William Thomson (Lord Kelvin 1824-1907) established the second law of thermodynamics. The second law is a statement that all processes go only

in one direction to a state of higher and higher entropy (in other words, in the direction of greater and greater degradation of energy). An isolated system always goes from a less probable to a more probable configuration. We hence have the following statement for the second law.

The first statement of the 2nd law: In any physical process, the entropy (S) for an isolated system never decreases; that is, we always have $\Delta S \geq 0$

Unlikely as it may sound, the second law is one of the few fundamental laws of physics that historically arose from very practical questions, in particular the need to understand the theory of heat engines. Carnot analyzed how much mechanical work could be extracted from heat, and what, in principle, is the most efficient heat engine that one could construct. His analysis was the beginning of the concept of entropy. It was only much later, in the work of Boltzmann, that there emerged a microscopic and more fundamental understanding of the principle of entropy. Based on the considerations of heat and work, we have a few other formulations of the second law.

The second statement of the 2nd law: No mechanical work can be extracted from an isolated system at a single temperature.

The third statement of the 2nd law: Heat cannot spontaneously flow from a cold body to a hot body. Although these formulations may seem to be a far cry from Statement I of the second law, it will be shown to be identical to it. Since only changes in entropy are defined, it was thought that there was an additive constant which would always be arbitrary. However, it was realized that this was not so.

The Third Law of Thermodynamics

The Third Law of Thermodynamics states that as temperature tends to absolute zero, so does entropy. In other words $S(T) \rightarrow 0$ as $T \rightarrow 0$

Carnot Cycle

The Carnot cycle is an idealized thermodynamic cycle that describes the most efficient thermal cycle possible, wherein there is no heat losses, and consisting of four reversible processes, two isothermal and two adiabatic. It has also been described as a cycle of expansion and compression of a reversible heat engine that does works with no loss of heat.

By using the second law of thermodynamics it is possible to show that no heat engine can be more efficient than a reversible heat engine working between two fixed temperature limits.

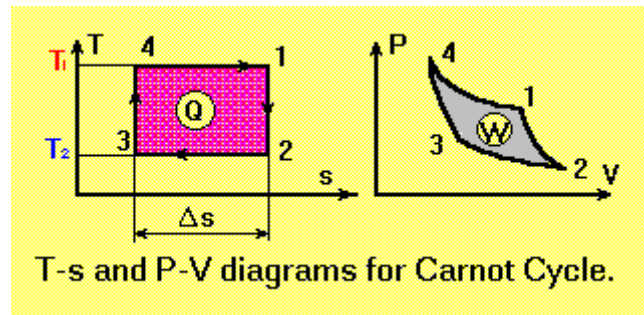

This heat engine is known as Carnot cycle and consists of the following processes:

- 1 to 2: Isentropic expansion
- 2 to 3: Isothermal heat rejection
- 3 to 4: Isentropic compression
- 4 to 1: Isothermal heat supply

The supplied heat to the cycle per unit mass flow is:

$$Q_1 = T_1 \Delta s$$

The rejected heat from the cycle per unit mass flow is:

$$Q_2 = T_2 \Delta s$$

By applying the first law of thermodynamics to the cycle, we obtain:

$$Q_1 - Q_2 - W = 0$$

And the thermal efficiency of the cycle will be:

$$\eta = W/Q_1 = 1 - T_2/T_1$$

Due to mechanical friction and other irreversibility's no cycle can achieve this efficiency. The gross work output of cycle, i.e. the work done by the system is:

$$W_g = W_{4-1} + W_{1-2}$$

and work ratio is defined as the ratio of the net work, W , to the gross work output, W_g , i.e.

$$W / W_g$$

The Carnot cycle has a low work ratio. Although this cycle is the most efficient system for power generation theoretically, it can not be used in practice. There are several reasons such as low work ratio, economical aspects and practical difficulties.

In a perfect Carnot cycle, all four steps happen very slowly, to minimize the entropy, or thermodynamic irreversibility, created by the process. In reality, the steps progress quickly, and entropy is generated, meaning the cycle can't go on forever. The walls of the cylinder degrade, heat from the interior of the engine gets lost to external surroundings, and so on. The Carnot cycle can be run in reverse to create a refrigerator.

Vapor Compression Cycle

The vapor compression cycle is based on a reverse Carnot Cycle. The Carnot cycle consists of (a) two isentropic processes and (b) two constant-pressure and temperature processes. The sequence of events in the Carnot cycle is as follows:

- 1) Wet vapor refrigerant enters the compressor and is compressed isentropically, increasing the refrigerant's temperature and pressure.
- 2) High-temperature refrigerant enters the heat exchanger (condenser) and heat is rejected from the refrigerant to the surrounding atmosphere at constant pressure and temperature.
- 3) The refrigerant is expanded isentropically in an expander which reduces the temperature and pressure of refrigerant.
- 4) Low-temperature refrigerant enters the heat exchanger (evaporator) and receives heat from the surrounding atmosphere at constant pressure and temperature.

To make a practical refrigeration cycle, three modifications are introduced in the Carnot cycle. These are:

- 1) Refrigerant is compressed in the superheated region instead of the wet region.

- 2) Condensed liquid is subcooled before entering next step.
- 3) Expander is replaced by a throttle valve.

HEAT

Heat is a form of energy, primarily created by the transformation of other types of energy into heat energy. For example, mechanical energy turning a wheel causes friction which creates heat.

Heat is often defined as energy in transfer, for it is never content to stand still, but is always moving from a warm body to a colder body. Heat exists at any temperature above absolute zero, even though it may be in extremely small quantities. Absolute zero is the term used by scientists to describe the lowest theoretical temperature possible, the temperature at which no heat exists, which is approximately 460 degrees below zero Fahrenheit. Note the following:

- 1) Heat is a form of energy that is transferred from one object to another object.
- 2) Heat is a form of energy transferred by a difference in temperature.
- 3) Heat transfer can occur, when there is a temperature difference between two or more objects.
- 4) Heat will only flow from a warm object to a colder object.
- 5) The heat transfer is greatest, when there is a large temperature difference between two objects.

TEMPERATURE

Temperature is the scale used to measure the intensity of heat, the indicator that determines which way the heat energy will move. In the United States, temperature is normally measured in degrees Fahrenheit, but the Centigrade scale (sometimes termed Celsius) is widely used in other parts of the world. Both scales have two basic points in common, the freezing point of water, and the boiling point of water at sea level. Water freezes at 32° F and 0°C, and water boils at sea level at 212° F and 100°C. On the Fahrenheit scale, the temperature difference between these two points is divided into 180 equal increments or degrees F, while on the Centigrade scale the temperature difference is divided into 100 equal increments or degrees C, The relation between Fahrenheit and Centigrade scales can always be established by the following formulas:

$$\text{Fahrenheit} = 1.8(\text{Centigrade} + 32^{\circ})$$

$$\text{Centigrade} = .556(\text{Fahrenheit} - 32^{\circ})$$

HEAT MEASUREMENT

The measurement of temperature has no relation to the quantity of heat. A match flame may have the same temperature as a bonfire, but obviously the quantity of heat given off is vastly different.

The amount of heat added to, or subtracted from, a body can best be measured by the rise or fall in temperature of a known weight of a substance. The standard unit of heat measure is the amount of heat necessary to raise the temperature of 1 pound of water 1°F at sea level when the water temperature is between 32°F and 212°F. Conversely, it is also the amount of heat that must be extracted to lower by 1°F the temperature of a pound of water between the same temperature limits. This unit of heat is called a British thermal unit (Btu). The Btu's equivalent in the metric system is the calorie, which is the amount of heat required to raise one gram of water 1°Celsius.

Suppose that the temperature of 2 pounds of water was raised from 35°F to 165°F. To find the number of Btu required to increase the temperature, subtract 35 from 165. This equals a 130° temperature rise for 1 pound of water. Since 2 pounds of water were heated, multiply 130 by 2, which equals 260 Btu required raising 2 pounds of water from 35°F to 165°F.

HEAT TRANSFER

Heat flows from a substance of higher temperature to bodies of lower temperature in the same manner that water flows down a hill, and like water, it can be raised again to a higher level so that it may repeat its cycle. When two substances of different temperatures are brought in contact with each other, the heat will immediately flow from the warmer substance to the colder substance. The greater the difference in temperature between the two substances, the faster the heat flow. As the temperature of the substances tends to equalize, the flow of heat slows and stops completely when the temperatures are equalized. This characteristic is used in refrigeration. The heat of the air, of the lining of the refrigerator, and of the food to be preserved is transferred to a colder substance, called the refrigerant. Three methods by which heat may be transferred from a warmer substance to a colder substance are conduction, convection, and radiation.

- 1) Radiation is the transfer of heat by waves similar to light waves or radio waves. For example, the sun's energy is transferred to the Earth by radiation. One need only step from the shade into direct sunlight to feel the impact of the heat waves, even though the temperature of the surrounding air is identical in both places. There is little radiation at low temperatures and at small temperature differences, so radiation is of little importance in the actual refrigeration process. However, radiation to the refrigerated space or product from the outside environment, particularly the sun, may be a major factor in the refrigeration load.
- 2) Conduction is the flow of heat through a substance. Actual physical contact is required for heat transfer to take place between two bodies by this means. Conduction is a highly efficient means of heat transfer as any service-man who has touched a piece of hot metal can testify.
- 3) Convection is the flow of heat by means of a fluid medium, either gas or liquid, normally air or water. Air may be heated by a furnace, and then discharged into a room to heat objects in the room by convection.

In a typical refrigeration application, heat normally will travel by a combination of processes, and the ability of a piece of equipment to transfer heat is referred to as the overall rate of heat transfer. While heat transfer cannot take place without a temperature difference, different materials vary in their ability to conduct heat. Metal is a very good heat conductor, while asbestos has so much resistance to heat flow it can be used as insulation.

BRITISH THERMAL UNITS (BTU's)

An air conditioner's capacity is measured in "British Thermal Units", or BTUs. A BTU is the amount of heat required to raise, by one degree, the temperature of a pound of water. So if you buy an air conditioner rated at 10,000 BTUs, it has the ability to cool 10,000 pounds -- about 1,200 gallons -- of water, one degree in an hour. Refrigeration is normally measured in "Tons"; 12,000 BTU's equal 1 ton.

SPECIFIC HEAT

SPECIFIC HEAT is the ratio between the quantity of heat required to change the temperature of 1 pound of any substance 1°F, as compared to the quantity of heat required to change 1 pound of water 1°F. Specific heat is equal to the number of Btu required to raise the temperature of 1 pound of a substance 1°F. For example, the specific heat of milk is .92, which means that 92 Btu will be needed to raise 100 pounds of milk 1° F. The specific heat of water is 1, by adoption as a standard, and specific heat of

another substance (solid, liquid, or gas) is determined experimentally by comparing it to water. Specific heat also expresses the heat-holding capacity of a substance compared to that of water.

A key rule to remember is that 0.5 Btu of heat is required to raise 1 pound of ice 1° F when the temperature is below 32°F; and 0.5 Btu of heat is required to raise 1 pound of steam 1°F above the temperature of 212°F.

CHANGE OF STATE

Most common substances can exist as a solid, a liquid, or a vapor, depending on their temperature and the pressure to which they are exposed. Heat can change their temperature, and also can change their state. Heat is absorbed even though no temperature change takes place when a solid changes to a liquid, or when a liquid changes to a vapor. The same amount of heat is given off when the vapor changes back to a liquid, and when the liquid is changed to a solid.

The most common example of this process is water, which exists as a liquid, can exist in solid form as ice, and exists as a gas when it becomes steam. As ice it is a usable form of refrigeration, absorbing heat as it melts at a constant temperature of 32° F. If placed in an open pan, its temperature will rise to the boiling point (212° F at sea level). Regardless of the amount of heat applied, the temperature cannot be raised above 212° F because the water will completely vaporize into steam. If this steam could be enclosed in a container and more heat applied, then the temperature could again be raised. Obviously the boiling or evaporating process was absorbing heat.

When steam condenses back into water it gives off exactly the same amount of heat that it absorbed evaporating. (The steam radiator is a common usage of this source of heat). If the water is to be frozen into ice, the same amount of heat that is absorbed in melting must be extracted by some refrigeration process to cause the freezing action.

SENSIBLE HEAT

Sensible heat is defined as the heat involved in a change of temperature but not in state. When the temperature of water is raised from 32° F to 212° F, an increase in sensible heat content is taking place. The BTU's required to raise the temperature of one pound of a substance 1°F is termed its specific heat. By definition the specific heat of water is 1.0, but the amount of heat required to raise the temperature of different substances through a given temperature range will vary.

LATENT HEAT

Latent Heat is the heat given up or absorbed by a substance as it changes state. It is called latent because it is not associated with a change in temperature. Each substance has a characteristic latent heat of fusion, latent heat of vaporization and latent heat of sublimation.

LATENT HEAT OF FUSION

A change of substance from a solid to a liquid, or from a liquid to a solid involves the latent heat of fusion. It might also be termed the latent heat of melting, or the latent heat of freezing.

When one pound of ice melts, it absorbs 144 BTU's at a constant temperature of 32° F, and if one pound of water is to be frozen into ice, 144 BTU's must be removed from the water at a constant temperature of 32°F. In the freezing of food products, it is only the water content for which the latent heat of freezing must be taken into account, and normally this is calculated by determining the percentage of water content in a given product.

LATENT HEAT OF VAPORIZATION

A change of a substance from a liquid to a vapor, or from a vapor back to a liquid involves the latent heat of evaporation. Since boiling is only a rapid evaporating process, it might also be called the latent heat of boiling, the latent heat of vaporization, or for the reverse process, the latent heat of condensation.

When one pound of water boils or evaporates, it absorbs 970 BTU's at a constant temperature of 212° F. (at sea level) and to condense one pound of steam to water 970 BTU's must be extracted from it.

Because of the large amount of latent heat involved in evaporation and condensation, heat transfer can be very efficient during the process. The same changes of state affecting water apply to any liquid, although at different temperatures and pressures.

The absorption of heat by changing a liquid to a vapor and the discharge of that heat by condensing the vapor is the keystone to the whole mechanical refrigeration process, and the movement of the latent heat involved is the basic means of refrigeration.

LATENT HEAT OF SUBLIMATION

A change in state directly from a solid to a vapor without going through the liquid phase can occur in some substances. The most common example is the use of "dry ice" or solid carbon dioxide for cooling. The same process can occur with ice below the freezing point, and is also utilized in some freeze-drying processes at extremely low temperatures and high vacuums. The latent heat of sublimation is equal to the sum of the latent heat of fusion and the latent heat of evaporation.

SATURATION TEMPERATURE

Saturation Temperature can be defined as the temperature of a liquid, vapor, or a solid, where if any heat is added or removed, a change of state takes place. For water at sea level, the saturation temperature is 212° F. At higher pressures, the saturation temperature increases, and with a decrease in pressure, the saturation temperature decreases.

- 1) A change of state transfers a large amount of energy.
- 2) At saturation temperature, materials are sensitive to additions or removal of heat.
- 3) Water is an example of how saturation property of a material, can transfer a large amount of heat.
- 4) Refrigerants use the same principles as ice. For any given pressure, refrigerants have a saturation temperature.
- 5) If the pressure is low, the saturation temperature is low. If pressure is high, saturation temperature is high.

SUPERHEATED VAPOR

After a liquid has changed to a vapor, any further heat added to the vapor raises its temperature so long as the pressure to which it is exposed remains constant. Since a temperature rise results, this is sensible heat. The term superheated vapor is used to describe a gas whose temperature is above its boiling or saturation point. The air around us is composed of superheated vapor. Refrigerant vapor is heated above its saturation temperature. If a refrigerant is superheated, there is no liquid present. Superheat is an indication of how full the evaporator is of liquid refrigerant. *High superheat means the evaporator is empty. Low superheat means the evaporator is full.*

SUB-COOLED LIQUID

Any liquid which has a temperature lower than the saturation temperature corresponding to its pressure is said to be sub-cooled. Water at any temperature less than its boiling temperature (212°F at sea level) is sub-cooled.

Sub-cooling is a temperature below saturated pressure-temperature. Sub-cooling is a measurement of how much liquid is in the condenser. In refrigeration, it is important to measure sub-cooling because the longer the liquid stays in the condenser, the greater the sensible (visible) heat loss. Low sub-cooling means that a condenser is empty. High sub-cooling means that a condenser is full. Over filling a system, increases pressure due to the liquid filling of a condenser that shows up as high sub-cooling. To move the refrigerant from condenser to the liquid line, it must be pushed down the liquid line to a metering device. If a pressure drop occurs in the liquid line and the refrigerant has no sub-cooling, the refrigerant will start to re-vaporize (i.e. changes state from a liquid to a vapor) before reaching the metering device.

ATMOSPHERIC PRESSURE

The atmosphere surrounding the Earth is composed of gases, primarily oxygen and nitrogen, extending many miles above the surface of the Earth. The weight of that atmosphere pressing down on the Earth creates the atmospheric pressure in which we live. At a given point, the atmospheric pressure is relatively constant except for minor changes due to changing weather conditions. For purposes of standardization and as a basic reference for comparison, the atmospheric pressure at sea level has been universally accepted, and this has been established at 14.7 pounds per square inch, which is equivalent to the pressure exerted by a column of mercury 29.92 inches high.

At altitudes above sea level, the depth of the atmospheric blanket surrounding the Earth is less, therefore the atmospheric pressure is less. At 5,000 feet elevation, the atmospheric pressure is only 12.2 pounds per square inch.

ABSOLUTE PRESSURE

Absolute pressure, normally expressed in terms of pounds per square inch absolute (psia) is defined as the pressure existing above a perfect vacuum. Therefore in the air around us, absolute pressure and atmospheric pressure are the same.

GAUGE PRESSURE

A pressure gauge is calibrated to read 0 pounds per square inch when not connected to a pressure producing source. Therefore the absolute pressure of a closed system will always be gauge pressure plus atmospheric pressure. Pressures below 0 psig are actually negative readings on the gauge, and are referred to as inches of vacuum. A refrigeration compound gauge is calibrated in the equivalent of inches of mercury for negative readings. Since 14.7 psi is equivalent to 29.92 inches of mercury, 1 psi is approximately equal to 2 inches of mercury on the gauge dial.

It is important to remember that gauge pressures are only relative to absolute pressure. Table 1 shows relationships existing at various elevations assuming that standard atmospheric conditions prevail.

PRESSURE RELATIONSHIPS AT VARYING ALTITUDES

Altitude	Psig	Psia	Pressure in Inches, Hg	Boiling Point of Water
0 ft.	0	14.7	29.92	212 degrees F
1000 ft.	0	14.2	28.85	210 degrees F

Altitude	Psig	Psia	Pressure in Inches, Hg	Boiling Point of Water
2000 ft.	0	13.7	27.82	208 degrees F
3000 ft.	0	13.2	26.81	206 degrees F
4000 ft.	0	12.7	25.84	205 degrees F
5000 ft.	0	12.2	24.89	203 degrees F

The absolute pressure in inches of mercury indicates the inches of mercury vacuum that a perfect vacuum pump would be able to reach. Therefore, at 5,000 feet, elevation under standard atmospheric conditions, a perfect vacuum would be 24.89 inches of mercury, as compared to 29.92 inches of mercury at sea level.

At very low pressures, it is necessary to use a smaller unit of measurement since even inches of mercury are too large for accurate reading. The micron, a metric unit of length, is used for this purpose, and when we speak of microns in evacuation, we are referring to absolute pressure in units of microns of mercury.

A micron is equal to 1/1000 of a millimeter and there are 25.4 millimeters per inch. One micron, therefore, equals 1/25,400 inch. Evacuation to 500 microns would be evacuating to an absolute pressure of approximately .02 inch of mercury, or of standard conditions, the equivalent of a vacuum reading of 29.90 inches mercury.

PRESSURE-TEMPERATURE RELATIONSHIPS, LIQUIDS

The temperature at which a liquid boils is dependent on the pressure being exerted on it. The vapor pressure of the liquid, which is the pressure being exerted by the tiny molecules seeking to escape the liquid and becomes vapor, increases with an increase in temperature until at the point where the vapor pressure equals the external pressure, boiling occurs.

Water at sea level boils at 212° F but at 5,000 feet elevation it boils at 203° F due to the decreased atmospheric pressure. If some means, a compressor for example, were used to vary the pressure on the surface of the water in a closed container, the boiling point could be changed at will. At 100 psig, the boiling point is 327.8°F, and at 1 psig, the boiling point is 102° F.

Since all liquids react in the same fashion, although at different temperatures and pressure, pressure provides a means of regulating a refrigerating temperature. If a cooling coil is part of a closed system isolated from the atmosphere and a pressure can be maintained in the coil equivalent to the saturation temperature (boiling point) of the liquid at the cooling temperature desired, then the liquid will boil at that temperature as long as it is absorbing heat -- and refrigeration has been accomplished.

PRESSURE-TEMPERATURE RELATIONSHIPS, GASES

One of the basic fundamentals of thermodynamics is called the "perfect gas law." This describes the relationship of the three basic factors controlling the behavior of a gas--pressure, volume, and temperature. For all practical purposes, air and highly superheated refrigerant gases may be considered perfect gases, and their behavior follows the following relation:

$$\text{Pressure} \times \text{Volume} / \text{Temperature} = \text{Pressure} \times \text{Volume} / \text{Temperature}$$

Although the "perfect gas" relationship is not exact, it provides a basis for approximating the effect on a gas of a change in one of the three factors. In this relation, both pressure and temperature must be expressed in absolute values, pressure in psia, and temperature in degrees Rankine or degrees Fahrenheit above absolute zero (degrees F plus 460 degrees). Although not used in practical refrigeration work, the perfect gas relation is valuable for scientific calculations and is helpful in understanding the performance of a gas.

One of the problems of refrigeration is disposing of the heat which has been absorbed during the cooling process, and a practical solution is achieved by raising the pressure of the gas so that the saturation or condensing temperature will be sufficiently above the temperature of the available cooling medium (air or water) to insure efficient heat transfer. When the low pressure gas with its low saturation temperature is drawn into the cylinder of a compressor, the volume of the gas is reduced by the stroke of the compressor piston, and the vapor is discharged as a high pressure gas, readily condensed because of its high saturation temperature.

SPECIFIC VOLUME

Specific volume of a substance is defined as the number of cubic feet occupied by one pound, and in the case of liquids and gases, it varies with the temperature and the pressure to which the fluid is subjected. Following the perfect gas law, the volume of a gas varies with both temperature and pressure. The volume of a liquid varies with temperature, but within the limits of practical refrigeration practice, it may be regarded as incompressible.

DENSITY

The density of a substance is defined as weight per unit volume, and is normally expressed in pounds per cubic foot. Since by definition density is directly related to specific volume, the density of a gas may vary greatly with changes in pressure and temperature, although it still remains a gas. Water vapor or steam at 50 psia pressure and 281° F temperature is over 3 times as heavy as steam at 14.7 psia pressure and 212° F.

PRESSURE AND FLUID HEAD

It is frequently necessary to know the pressure created by a column of liquid, or possibly the pressure required to force a column of refrigerant to flow a given vertical distance upwards. Densities are usually available in terms of pounds per cubic foot, and it is convenient to visualize pressure in terms of a cube of liquid one foot high, one foot wide, and one foot deep. Since the base of this cube is 144 square inches, the average pressure in pounds per square inch is the weight of the liquid per cubic foot divided by 144. For example, since water weighs approximately 62.4 pounds per cubic foot, the pressure exerted by 1 foot of water is $62.4 / 144 = .433$ pounds per square inch. Ten feet of water would exert a pressure of $10 \times .433 = 4.33$ pounds per square inch. The same relation of height to pressure holds true, no matter what the area of vertical liquid column. The pressure exerted by other liquids can be calculated in exactly the same manner if the density is known.

Fluid head is a general term used to designate any kind of pressure exerted by a fluid which can be expressed in terms of the height of a column of the given fluid. Hence a pressure of 1 psi may be expressed as being equivalent to a head of 2.31 feet of water ($1 \text{ psi} / .433 \text{ psi/ft of water}$). In air flow through ducts, very small pressures are encountered, and these are commonly expressed in inches of water $1 \text{ inch of water} = .433 / 12 = .036 \text{ psi}$.

PRESSURE EQUIVALENTS IN FLUID HEAD

Pounds per Square inch	Inches, Hg	Inches, H ₂ O	Feet, H ₂ O
.036	.07	1.0	.083
.433	.80	12	1.0
.491	1.0	13.6	1.13
1.0	2.03	27.7	2.31
14.7	29.92	408	34.0

FLUID FLOW

In order for a fluid to flow from one point to another, there must be a difference in pressure between the two points to cause the flow. With no pressure difference, no flow will occur. Fluids may be either liquids or gases, and the flow of each is important in refrigeration.

Fluid flow through pipes or tubing is governed by the pressure exerted on the fluid, the effect of gravity due to the vertical rise or fall of the pipe, restrictions in the pipe resisting flow, and the resistance of the fluid itself to flow.

For example, as a tap is opened, the flow increases, even though the pressure in the water main is constant and the outlet of the faucet has no restriction. Obviously the restriction of the valve is affecting the rate of flow. Water flows more freely than molasses, due to a property of fluids called viscosity, which describes the fluid's resistance to flow. In oils, the viscosity can be affected by temperature, and as the temperature decreases the viscosity increases.

As fluid flows through tubing, the contact of the fluid and the walls of the tube create friction, and therefore resistance to flow. Sharp bends in the tubing, valves and fittings, and other obstructions also create resistance to flow, so the basic design of the piping system will determine the pressure required to obtain a given flow rate.

In a closed system containing tubing through which a fluid is flowing, the pressure difference between two given points will be determined by the velocity, viscosity, and the density of fluid flowing. If the flow is increased, the pressure difference will increase since more friction will be created by the increased velocity of the fluid. This pressure difference is termed pressure loss or pressure drop.

Since control of evaporating and condensing pressures is critical in mechanical refrigeration work, pressure drop through connecting lines can greatly affect the performance of the system, and large pressure drops must be avoided.

EFFECT OF FLUID FLOW ON HEAT TRANSFER

Heat transfer from a fluid through a tube wall or through metal fins is greatly affected by the action of the fluid in contact with the metal surface. As a general rule, the greater the velocity of flow and the more turbulent the flow, the greater will be the rate of heat transfer. Rapid boiling of an evaporating liquid will

also increase the rate of heat transfer. Quiet liquid flow on the other hand, tends to allow an insulating film to form on the metal surface which resists heat flow, and reduces the rate of heat transfer.