



PDHonline Course S122 (3 PDH)

Design of Short Span Steel Bridges

Instructor: Frank Russo, Ph.D. & John C. Huang, Ph.D., PE

2020

PDH Online | PDH Center

5272 Meadow Estates Drive
Fairfax, VA 22030-6658
Phone: 703-988-0088
www.PDHonline.com

An Approved Continuing Education Provider

Design of Short Span Steel Bridges

DESIGN REQUIREMENTS

- ◆ Safety
 - Strength to support unexpected loads
- ◆ Serviceability
 - Fatigue resistant over expected life
 - Controlled deflections & vibrations to ensure rideability
- ◆ Constructibility
 - Adequate strength & stability
- ◆ Economy and Aesthetics

For the design of bridges, the most important design objective is safety. Bridges must have adequate strength to support expected and unexpected loads. At service load level, the structure must provide an adequate ride quality, not undergo excessive deflections and be robust enough to withstand repeated applications of live load. Additionally, safety of the structure during construction must be considered. Stability of the main stringers during construction is the primary role of intermediate diaphragms and cross frames in many steel bridges. Other important aspects of steel bridge design are considerations of the design features that positively or negatively impact a structures aesthetic qualities as well as initial and life-cycle costs.

AASHTO LOAD FACTOR DESIGN

◆ Safety

$$M_u > 1.3 [M_{DL} + 1.67 M_{L(1+I)}]$$

$$V_u > 1.3 [V_{DL} + 1.67 V_{L(1+I)}]$$

◆ Serviceability

- Stress from $M_{DL} + 1.67 M_{L(1+I)} < 0.95F_y$ (composite)
 $< 0.80F_y$ (non-composite)
- Deflections from $L(1+I) < L/800$ (no pedestrians)
 $< L/1000$ (w/ pedestrians)
- Fatigue from $L(1+I)$ stress range $<$ detail allowable stresses

Load factor design method is a method that considers the structures ability at its theoretical strength to support factored loads. The loads considered are typically the self weight of materials (dead load), loads from traffic (live load), and the dynamic effects of moving traffic (impact). The moment capacity and shear capacity of the beam must be greater than a load combination of the factored dead, live and impact loads. The method is called load factor design.

The design of a structure also requires serviceability checks to be made. For serviceability checks, there are three specific areas. The first one relates to the overload. The overload on a structure caused by a large live load must not be such that it will cause permanent deformations or yielding of the beams. This check is made with the nominal dead loads and an elevated live load between the service live load and the factored extreme live load.

Additionally, deflection checks under live load are typically required. The deflection due to the unfactored live loads must be less than span length L over 800 ($L/800$) for bridges without pedestrians and $L/1000$ for bridges with pedestrians. These deflection limits are an indirect method of trying to control the frequency of vibration of the bridge.

The third requirement for serviceability, and in some respects the most important consideration for steel bridges, is that fatigue from the live load stress range must be less than the allowable stress for the detail. We will look at fatigue in greater detail later but it is a phenomenon related to cumulative damage to steel resulting from the repeated applications of live load.

AASHTO HS Live Loads

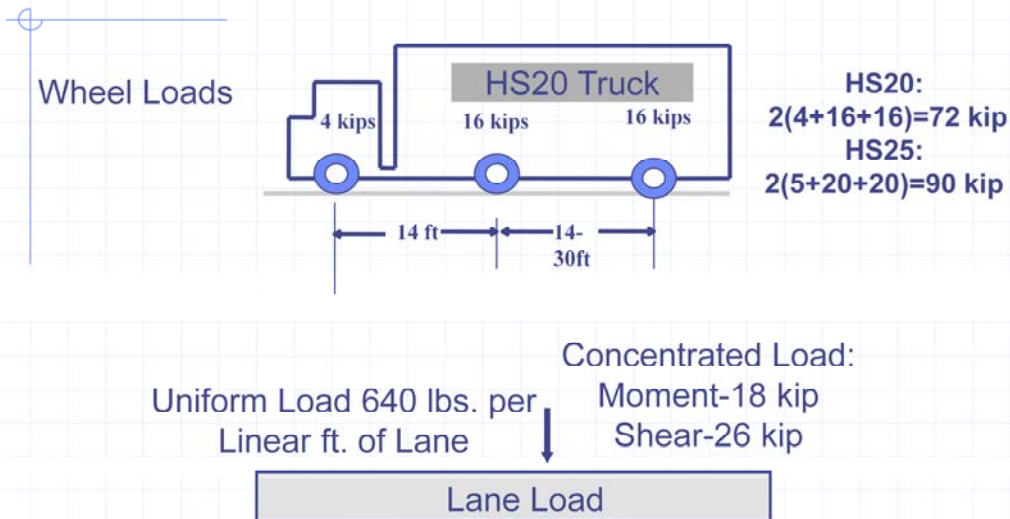

There are two classes of design live loads recommended by AASHTO, truck load and lane load. The standard truck load that is used for design is an HS20 Truck. In many jurisdictions and in response to increases in truck weights, an elevated, but not code mandated live load equal to HS25 is used. This live load is simply a 25% increase in axle (wheel) loads over the AASHTO prescribed HS20 loading. The standard HS20 live load consists of three wheels, the loads being 4 kips, 16 kips and 16 kips. This is the load for one wheel, i.e. half of the axle load. The distance between the first and second axles is 14 feet. The distance between the second and third axles can vary from 14 feet to 30 feet with the spacing chosen by the engineer to generate maximum force effects. For simply supported bridges, keeping the axle spacing at a constant 14 ft will generate the maximum response. The second type of mandated live load is a lane load. The lane load consists of a uniformly distributed load with a single concentrated load placed to generate the maximum force. In summary, live load design is done using either the truck load or the combination of the lane load with a concentrated load, whichever one governs the design.

Live Load Effects

◆ Load Distribution

- Fraction of Load Resisted by Most Heavily Loaded Member

◆ Live Load Impact

- Approximate Methods to Account for Dynamic Effect of Moving Vehicles

In order to design a main member in a multi-stringer bridge, two important effects must be considered, live load distribution and the dynamic effect known as impact.

Live load distribution involves the use of empirical formulas, based on analytical and experimental methods, that attempt to quantify the total amount of a vehicle load resisted by the most heavily loaded member(s). To design a bridge, we typically do not place discrete trucks on the bridge and compute the load distribution effects because the analysis is highly complicated usually requiring the use of advanced analysis techniques such as the finite element method or other computer based procedures. Instead, empirical approaches such as the AASHTO load distribution factor approach is used. There are separate methods of computing the load distribution effect for exterior and interior stringers and a separate computation as well for the distribution of wheel loads applied at the end of a member over a support. This is known as the distribution effect for end shear.

Similar to load distribution, approximate methods are used to compute the dynamic effects of moving traffic on a bridge. The actual dynamic effect depends on many things such as the vibration characteristics of the bridge, vehicle suspension properties and surface roughness of the bridge deck and approach pavement. Knowing the complexity of such a problem, approximate dynamic amplification factors, known as the impact factor, are used as an increase of the static design load.

Live Load Distribution Factors for Beam & Slab Bridges

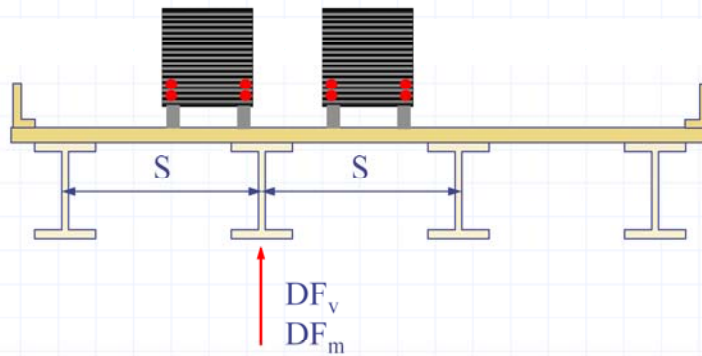

- ◆ Distribution Factors Vary for Interior & Exterior Beams and for Shear and Moment

This simple picture illustrates the fact that impact factors attempt to capture the amount of load on the most heavily loaded member from all possible combinations of number of vehicles and truck positions. The actual location and number of lanes is not needed for the typical design of multi-stringer bridges.

LIVE LOAD & IMPACT MOMENTS/SHEARS

- ◆ Girder Live Load M & $V = M_{L(1+I)}, V_{L(1+I)}$

- ◆ M_L or $V_L = (\text{wheel line } M \text{ or } V) * DF$

- ◆ $DF = \text{fraction of wheel line on one girder}$
 $= S/D$ for interior steel stringers where S is the girder spacing (ft) and D is typically equal to 5.5

- ◆ $I = \text{impact factor} = \frac{50}{\text{Span} + 125} \leq 0.30$

The design live loads (HS 20, 25, etc.) are used along with the anticipated dead loads to determine the design moments and shears for the steel beam. M_L is multiplied by the impact factor I . M_L and V_L represent the moment and the shear due to the live loads. M_L and V_L can be estimated by using wheel line moment or shear multiplied by the distribution factor. The distribution factor determines the fraction of the wheel line resisted by the most heavily loaded member. There are several formulas for the distribution factor depending on whether moment or shear is being considered for either interior or exterior beams. For moment and shear in interior beams with loads applied out in the span, the distribution factor can be estimated by girder spacing S divided by D . D is typically equal to 5.5 for the design of multiple steel stringer bridges supporting a concrete deck. The impact factor I corresponds to 50 divided by span length plus 125, but is limited to a value of 0.3. To summarize, the live load effect is estimated from the live load multiplied by the distribution factor which accounts for the lateral distribution of the live load over several beams and the impact factor.

Live Load Distribution Factors for Interior Beams/Girders

"End Shear" AASHTO 3.23.1

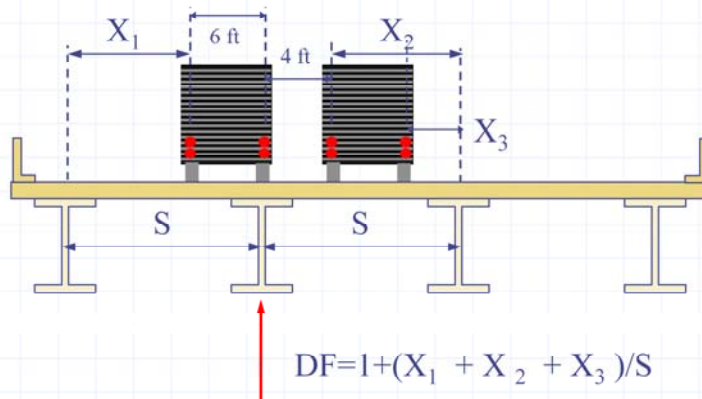

The method prescribed by AASHTO for end shear determination uses the simple beam approach. In the simple beam distribution approach, the slab is treated as a simply supported beam spanning between stringers and the reaction at the most heavily loaded stringer is computed. This reaction is the distribution factor for wheel loads applied at the end of the span. Note that for shear at the end of a simple span bridge for instance, the end axle (wheels) are distributed as above while for loads out in the span, the distribution is the same as that prescribed for moment, i.e., the "S Over" approach, typically, $S/5.5$ for multi stinger bridges where S is the beam spacing in feet.

Live Load Distribution Factors for Exterior Beams/Girders

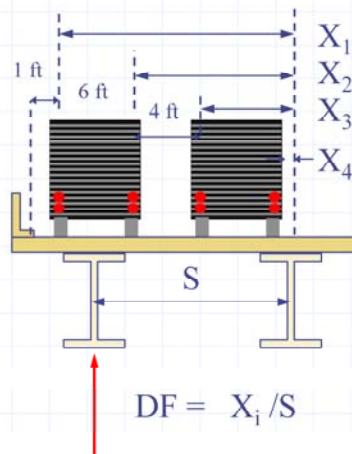

For ≥ 4 Beams

$$DF = \frac{S}{5.5} \text{ if } S \leq 6'$$

$$DF = \frac{S}{4 + 0.25S} \text{ for } 6' < S \leq 14'$$

Similar to interior stringers, which are typically the controlling elements in terms of total design force, empirical formulas also exist for live load distribution to exterior stringers. Although the total dead load and live load to an exterior stringer might tempt one to consider placing a beam of less capacity in the exterior location, such an approach is prohibited by code. The exterior elements, regardless of the lesser design load, must have at least the capacity of an interior stringer.

SAFETY

Strength for Maximum Load

$$M_u > 1.3 [M_{DL} + 1.67 M_{L(1+I)}]$$

$$V_u > 1.3 [V_{DL} + 1.67 V_{L(1+I)}]$$

M_u, V_u = nominal bending/shear strength

M_{DL}, V_{DL} = dead load moment/shear

$M_{L(1+I)}, V_{L(1+I)}$ = girder LL moment/shear + impact

We are talking about load factor design method. In this design, the structural strength must be greater than the factored load effects. AASHTO specifies a number of load combinations that must be considered for bridge design. However, the typical load combination for superstructure design is the Group I load combination. For Group I, the factored load effects use a factor of 1.3 multiplied by the sum of the moments due to dead load plus the factored live load with a live load factor of 1.67. Therefore, the total effect is 1.3*dead loads plus 1.3*1.67=2.17 times the live load plus impact effect. M_u and V_u are nominal bending and shear strength of the beam itself. M_{DL} and V_{DL} are moments and shears caused by the dead load, while $M_{L(1+I)}$ and $V_{L(1+I)}$ are moments and shears caused by the live load and increased by the impact factor.

MEMBER BENDING STRENGTH

Member Bending Strength M_u Non-Composite Sections

Check:

- ◆ Compression-Flange Bracing to prevent lateral-torsional buckling of girder
- ◆ Compression Flange and Web Slenderness to prevent web and flange local buckling



The bending strength for non-composite sections primarily consists of limit states of lateral-torsional buckling, compression flange buckling and web local buckling. These are traditional slenderness checks for steel beam design. The moment capacity of the beam can be equal to M_p if all the adequate slenderness limits are satisfied though this is uncommon for the non-composite condition. More realistically, the moment capacity of a rolled shape or plate girder bridge in the short to medium span range will be at or near to the yield capacity, M_y in the non-composite condition.

MEMBER BENDING STRENGTH

◆ Member Bending Strength M_u - Composite Sections

◆ Check:

- Ductility to prevent concrete crushing
- Web Slenderness to prevent web local buckling



For composite beams, the moment capacity is usually at or very near to the plastic moment capacity of the composite section. Shear studs are required to ensure full composite action. M_p , the plastic moment, corresponds to the crushing of the concrete and significant yielding and strain hardening of the steel. The location of the plastic neutral axis must be determined considering equilibrium of the tensile and compressive plastic forces. The section should be designed in such way so that the concrete crushing occurs after significant steel yielding and strain hardening has occurred. This is to ensure ductility in the event of an extreme overload. As a designer, one should design structures to prevent concrete crushing before steel yielding occurs because that will be a brittle failure mode. The slenderness of the web must be checked to assure that the web does not buckle laterally in the compression region.

SERVICEABILITY

Response to Overloads

Flange Stress from $M_{DL} + 1.67 M_{L(1+I)}$ -- Overload

$< 0.95F_y$ for composite sections

$< 0.80F_y$ for non-composite sections

to control permanent deflections (Yielding)

$$\text{Stress} = \frac{M_{DL1}}{S_{nc}} + \frac{M_{DL2}}{S_{3n}} + \frac{1.67 M_{L(1+I)}}{S_n}$$

Composite section

M_{DL1} = non-comp dead load moment

S_{nc} = non-comp section modulus

M_{DL2} = superimp. dead load moment

S_{3n} = long term comp section modulus

$M_{L(1+I)}$ = live load plus impact moment

S_n = short term comp section modulus

The Overload criteria is a serviceability design requirement for steel beams. For the overload check the stress in the tension flange due to the dead load plus an elevated live load of 1.67 times the live load and impact is limited. The stress caused by the design overload must be less than $0.95F_y$ for composite sections and $0.80F_y$ for the non-composite sections. The purpose of this limit is to control the permanent deflections under the specified load. The stress corresponding to the overload is calculated as shown in the above expression as the elastic superposition of several load effects. The dead loads consist of the non-composite dead loads and superimposed composite dead loads. The steel beam is subject to the dead load caused by its own weight, the weight of the slab and weight of the wearing surface. After the slab hardens, composite action occurs between the steel and concrete. There is additional dead load due to the additional wearing surfaces that are added over the years and the barriers that are placed on the composite section. M_{DL1} corresponds to the non-composite dead load moment and M_{DL2} corresponds to the superimposed dead load moment. Before the concrete hardens, S_{nc} is the section modulus for the non-composite section that is the beam by itself. S_{3n} is the reduced composite section modulus accounting for long term effects, that means creep of the concrete. The composite section is subject to additional dead loads caused by the barriers and wearing surfaces. These are long term loads and the effects of creep are accounted for. Additionally there is the live load moments and S_n is the short term composite section modulus without consideration of creep because live loads are a transient load.

SERVICEABILITY

Live Load Deflections

Deflections from L+I -- Service live load

preferably < Span/800 (no pedestrians)

< Span/1000 (w/ pedestrians)

Note: Live load deflection may be computed assuming girders act together and have equal deflection (AASHTO Art. 10.6.4). Therefore:

$$DDF = \frac{(2 \text{ wheels/lane}) * (\text{No. of lanes}) * (\text{Multiple lane reduction factor})}{\text{No. of girders}}$$

Another serviceability check relates to the deflections caused by the service live load. This is unfactored live load plus impact. The deflection caused by this load must be less than **L/800** if there are no pedestrians and **L/1000** if there are pedestrians on the bridge. Based on AASHTO specifications, the live load deflection can be computed assuming that the girders act together and have equal deflections. What this means is that the deflection distribution factor can be calculated by 2 wheels per lane multiplied by the number of lanes considering the multiple lane reduction factors. The whole bridge is assumed to act as an unit for the live load to estimate the deflections.

SERVICEABILITY

Live Load Deflections (cont'd)

◆ For a simple span (truck loading only):

$$\Delta_{LL} = \frac{324 P_T}{EI_n} (L^3 - 555L + 4,780) \quad \text{at midspan}$$

where : L = span length, ft

E = elastic modulus of steel, ksi

I_n = sum of short-term composite moments of inertia of all girders in the cross section, in.⁴

P_T = sum of the weights of the truck front wheels
* DDF * $(1 + I)$, kips

For a simple span with truck loading only, the maximum deflection at the mid span can be estimated using the above equation. The referenced equation is from a series of design examples for steel bridges prepared by the steel industry in the 1970's. In this equation, L is the span length and I_n is the moment of inertia of the completed bridge. The sum of the short term composite moments of inertia of all girders in the cross section is used to estimate the deflection caused by the unfactored live load. P_T is the sum of the weights of the truck front wheels multiplied by the deflection distribution factor and the impact factor. It is used to estimate the deflection for the live load.

FATIGUE

Cycles of Repeated Stress

For a simple span: $\frac{+M_{L(I+I)} + 0.0}{S_n} < F_{sr} = \text{allow. fatigue stress range}$

- ◆ Recommend use of AASHTO HS20 Service live load.
- ◆ AASHTO Table 10.3.1A gives F_{sr} as a function of *No. of Cycles & Category (redundant or non-redundant structure)*.
- ◆ Detail categories range from A to E' (AASHTO Table 10.3.1B).
- ◆ No. of cycles ranges from 100,000 to > 2,000,000 cycles.
- ◆ F_{sr} ranges from 63 ksi (Category A, redundant, low ADTT) to 1.3 ksi (Category E', non-redundant, high ADTT).

The third requirement for the serviceability design is fatigue. Fatigue is an important issue for steel bridges. The simple span is subject to the stress range that can be calculated as live load moment divided by the section modulus. This stress range must be less than the allowable stress range. AASHTO requires that HS20 service live load be used when designing for fatigue regardless of the value or type of live load being used. The stress range due to service load should be less than the allowable stress range. AASHTO specifies the allowable fatigue stress range depending upon the detail category and number of cycles for design. Therefore, for a given number of cycles for design and a given detail category, one can obtain the allowable fatigue stress range from the tables given in the AASHTO. The detail category varies from A to E', and the number of cycles ranges from 100,000 to over 2,000,000. The fatigue stress range values range from 63 ksi for Category A redundant structure with low Annual Daily Truck Traffic to 1.4 ksi for Category E' non-redundant structure with high ADTT. Most short and medium span steel bridges will have details no worse than a Category C, the classification of the welds typically used to connect shear and diaphragm connection plates to the webs and flanges of the stringers.

DESIGN EXAMPLE

- ◆ 80 ft Simple Span
- ◆ Composite
- ◆ HS25 Live Load
- ◆ M270 Grade 50W Steel
- ◆ Case II Roadway
- ◆ $f'_c = 4,000$ psi - normal wt.
- ◆ Load Factor Design
- ◆ Interior Girder

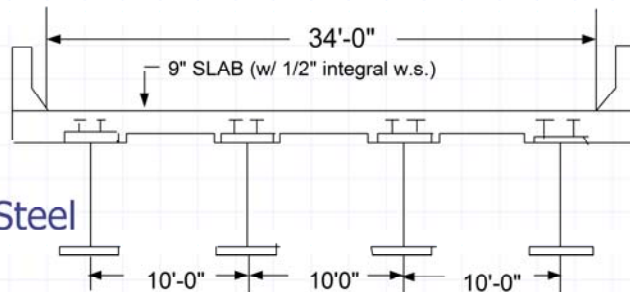

**Structural Slab
Thickness- 8.5"**

We have identified that in order for us to design a steel bridge, we need to design for strength and serviceability. For strength, we need to compare the moment capacity and the shear capacity of the bridge with the factored loads. For serviceability, we need to look at the overload effects, the deflections caused by the live loads and fatigue stress range. The best way to look at all these checks is through a design example. The example bridge we are going to use is a 80-ft simple span bridge. We will design it as composite steel girder bridge. HS25 will be used for the live load in this design example. We are using 50 ksi steel and Case II roadway. The Case II roadway corresponds to a certain number of cycles for truck loading and a certain number of cycles for lane loading. It corresponds to annual daily truck traffic which is less than 2500. The concrete strength is 4000 psi. We will be using load factor design to design one of the interior girders. The cross section of the bridge is shown above. We have four girders that are spaced at 10 feet each. The slab is 9" thick with 1/2" integral wearing surface. The structural slab thickness then becomes 8 1/2" because the 1/2" is the integral wearing surface. The roadway width is 34 feet.

Load Estimation and Calculation

- ◆ Slab thickness given = 9" (8.5" effective)
- ◆ Typical Stay-in-Place Steel Form Weight, Including Concrete in Form Valleys = 15 psf
- ◆ Assumed Haunch = 2"
- ◆ Typical Stringer (in this span range) = 15 plf per sq ft deck area supported.
- ◆ Assume 10% for bracing, studs, etc.
- ◆ Girder Wt. = $15\text{psf} \times 10\text{ft} \times 1.1 = 165\text{ plf}$

In order to begin our design, some assumptions need to be made regarding the magnitude of some of the loads. Since we have chosen, or previously designed our slab, it has a thickness of 9". This thickness will be used for self weight estimation though when we proceed to structural design, the top ½" of the slab will be discounted as it is prone to wear.

This design presumes the use of stay-in-place steel forms. These forms are typically corrugated and are permanent forms that remain in place following casting of the deck. A reasonable estimate for the self weight of the form as well as the non-contributing concrete that lays in the valleys of the forms is 15 psf.

A 2" haunch is presumed. This haunch is provided to allow for the cross slope of the deck and as a field adjustment for corrections between the camber of the beam and the vertical profile of the roadway surface. The haunch is not considered as structural concrete but is considered in load calculations.

Finally, some estimate must be made of the girders initial weight. In the span range considered for simple span steel bridges, i.e. less than say 120-150 ft, an accurate estimate of plate girder weights can usually be made. The plate girders typically weigh on the order of 15 – 25 plf per sq ft of deck supported. For our bridge we will assume 15 plf per sq ft, thus for a 10 ft beam spacing, we will assume a beam wt of 150 plf. We will allow an additional 10% for miscellaneous steel such as connection plates, shear studs, etc. The initial girder weight is estimated by the AISIBeam software.

DESIGN EXAMPLE

Uniformly Distributed Dead Loads

◆ Non-Composite Dead Load (DL1) Applied to Steel Section

- Slab (including integral w.s.) = $(9.0/12) * 10.0 * 0.150 = 1.125 \text{ kips/ft}$
 - Concrete haunch = $(2.0/12) * (12.0/12) * 0.150 = 0.025 \text{ kips/ft}$
 - Steel girder, cross frames and details = 0.165 kips/ft
 - Stay-in-place forms = $0.015 * [10.0 - (12.0/12)] = 0.135 \text{ kips/ft}$
- Total = 1.45 kips/ft**

◆ Superimposed Dead Load (DL2) Applied to Long Term 3n Composite Section

- Barriers = $[0.405 * 2] / 4 = 0.203 \text{ kips/ft}$
 - Future wearing surface = $[0.025 * (34.0)] / 4 = 0.213 \text{ kips/ft}$
- Total = 0.416 kips/ft**

The first step is to estimate the loads and the load effects. In order to design a composite beam, the dead load will be estimated in two parts. The first part corresponds to the load that placed on the beam before the concrete hardens. That includes the weight of slab, the weight of concrete haunch, the weight of steel girder, cross frames and details and the weight of stay-in-place forms. The superimposed dead load which applied to long term composite section includes the weight of barriers and the weight of future wearing surface. The weight of barriers and the weight of wearing surface is distributed over all four girders. So the weight of barriers is assumed to be carried by all the girders equally. Thus, the dead load turns out to be 1.45 kips/ft and superimposed dead load turns out to be 0.416 kips/ft for design. Estimating the dead loads was not that difficult, as you can see here.

DESIGN EXAMPLE

Live Load Moment

◆ HS25 Max. Moment Due to One Wheel Line
= 728 kip-ft (truck loading governs)

◆ Wheel-Load Lateral Distribution Factor
= $S/5.5 = 10.0/5.5 = 1.818$ wheels

◆ Impact Factor
$$= \frac{50}{Span + 125} = \frac{50}{80 + 125} = 0.24 < 0.30 \text{ ok}$$

◆ Therefore:
$$M_{L(I+I)} = 728(1.818)(1 + 0.24) = 1,641 \text{ kip-ft}$$
M (Dist.Fact.)(Impact)

While estimating the live load for this span, we found that truck loading governs the live load moments. The maximum moment was due to one wheel line of HS25 truck and caused the moment of 728 kip-ft. The wheel-load lateral distribution factor is estimated as S divided by 5.5 where S is the spacing of the beams, 10 feet. Therefore, we have a factor of 1.818 wheels. The impact factor is calculated as 50 divided by the span length plus 125. The factor for this bridge is 0.24, i.e., 24% increase in the static load. Thus, the maximum live load can be calculated as the moment due to the live load multiplied by the impact factor multiplied by the distribution factor, and it equals to 1,641 kip-ft.

Design Example End Shear Distribution Factor

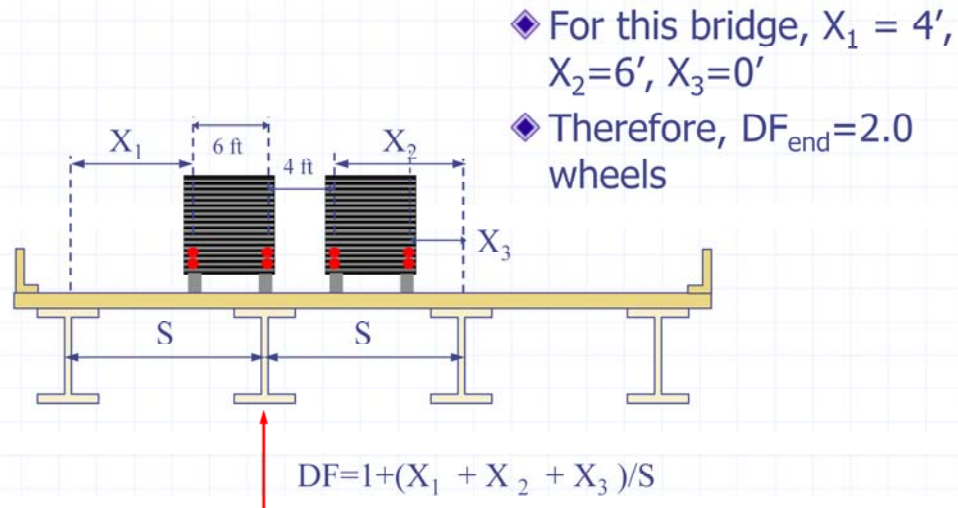

The method prescribed by AASHTO for loads applied at the end of a beam is the so called simple beam approach. In the simple beam distribution approach, the slab is treated as a simply supported beam spanning between beams and the fraction of each wheel load resisted by the most heavily loaded beam is computed. For a 10' beam spacing and one truck placed directly over one of the interior beams, the end shear distribution factor is 2.0 wheels.

Design Example

End Shear Calculations

◆ Shear Due to Each Wheel Load

- Wheels @ Abutment, $V = 20$ kips
- Wheels 14' from abutment, $V = 66/80 * 20k = 16.5$ kips
- Wheels 28' from abutment, $V = 52/80 * 20k = 13$ kips

◆ V @ End, including DF's & Impact =

$$\{(20)(2) + (16.5 + 13)(1.818)\}(1.24) = 94.4 \text{ kips}$$

This slide illustrates the combination of several aspects of shear force computation. First the undistributed shears at the end of the beam are calculated for each of the three axles of an HS25 notional load. For the axle at the end of the beam (the rear axle of the trailer), the shear is simply the force of the axle (wheel line) = 20 kips. For the next two axles (wheel lines) simple span beam statics of $V=P(b/L)$ are used to compute the shears due to the trailer leading axle and the axle under the cab.

The next step combines the wheel line forces with their respective distribution factors. For the wheel line at the end of the beam, the simple beam distribution factor of 2.0 is used while for the loads out in the span, the distribution is as for moment using the S/5.5 factor of 1.818. Finally, after combining the wheel loads together, the uniform impact factor of 24% is applied resulting in a distributed live load and impact shear of 94.4 kips.

DESIGN EXAMPLE

Factored Moment

- ◆ Non-Composite Dead Load Moment

$$M_{DL1} = 1,160 \text{ kip-ft}$$

- ◆ Superimposed Dead Load Moment

$$M_{DL2} = 333 \text{ kip-ft}$$

- ◆ HS25 Live Load plus Impact Moment

$$M_{L(1+I)} = 1,641 \text{ kip-ft}$$

- ◆ Maximum Load Moment - to check strength

$$M = 1.3[1,160 + 333 + 1.67(1,641)] = 5,504 \text{ k-ft}$$

The moments caused by the dead loads can be estimated as $wL^2/8$. The non-composite dead load moment is calculated to be 1,160 kips, and superimposed dead load moment is 333 kip-ft. The live load plus impact moment is calculated to be 1,641 kip-ft. The factors of 1.3 and 1.67 are applied as described previously resulting in a design moment of 5,504 kip-ft.

DESIGN EXAMPLE

Factored Shear

- ◆ Non-Composite Dead Load Shear

$$V_{DL1} = 58 \text{ kips}$$

- ◆ Superimposed Dead Load Shear

$$V_{DL2} = 16.6 \text{ kips}$$

- ◆ HS25 Live Load plus Impact Shear

$$V_{L(1+I)} = 94.4 \text{ kips}$$

- ◆ Maximum Load Shear - to check strength

$$V = 1.3[58 + 16.6 + 1.67(94.4)] = 302 \text{ kips}$$

The factored shear force can be calculated as $wL/2$, where w is the distributed dead load. The non-composite dead load shear is 58 kips, and superimposed dead load shear is calculated as 16.6 kip. We previously calculated the live load plus impact shear as 94.4 kips. Applying the appropriate load factors to these service loads results in a final design shear of 302 kips.

DESIGN EXAMPLE

Member Strength Composite Section

- ◆ Compute plastic moment M_p of composite section (AASHTO Art. 10.50.1.1.1):

Assumed section

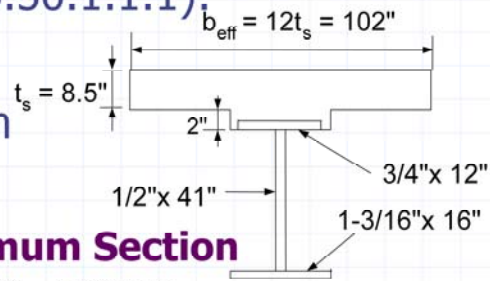

Program Determines Optimum Section

$$C = 0.85 f'_c b_{eff} t_s = 0.85(4.0)(102.0)(8.5) = 2,948 \text{ kips}$$

$$T = \sum AF_y = [12(0.75) + 41(0.5) + 16(1.1875)]50 = 2,425 \text{ kips (governs)}$$

Plastic Neutral Axis in Slab

The next step is to estimate the capacity of the beam to carry the loads. We want to compute the plastic moment of the composite section. The first thing will be to estimate the effective deck width which is calculated as the smallest value of three things. It turns out that in this case the 12 times the minimum slab thickness governs the value. The effective deck width is 102". The structural thickness of the slab is 8 1/2" and the haunch is 2". The girder shape that is used in this design is asymmetrical with a smaller compression flange and a wider tension flange. The plate thickness is 3/4" for compression flange, 1 3/16" for the tension flange and 1/2" for the web. This is reasonably stocky web but results in a fairly simple web to fabricate, one that does not require shear stiffeners, only diaphragm connection plates. This is the section selected by AISIBeam as an optimum design. The presentation of this computer program is included in the PDHonline Course 115, Computer Aided Design and Detailing of Short Span Steel Bridges. The first order is to calculate the location of the plastic neutral axis through force equilibrium. The compression forces of the section must be equal to the tensile forces. We calculate the compression force assuming the entire slab will be in compression. The compression capacity of the slab is 2,948 kips. If you assume the plastic neutral axis lies at bottom of the slab, the entire steel beam will be in tension, a tensile capacity of 2,425 kips. Since this is less than the plastic compressive load carrying capacity of the concrete, the plastic neutral axis will lie in the slab. With the plastic neutral axis inside the slab and the requirement that compression = tension, the location of the PNA can be determined.

DESIGN EXAMPLE

Member Strength (cont'd)

◆ Compute M_p (cont'd):

$$a = \frac{C}{0.85 f'_c b} = \frac{2,425}{0.85(4.0)(102.0)} = 6.99 \text{ in.}$$

$$M_p = \left[\begin{array}{l} \frac{0.85(4.0)(102.0)(6.99)^2}{2} + \\ 12(0.75)(50)(3.135) + \\ 41(0.5)(50)(24.01) + \\ 16(1.1875)(50)(45.104) \end{array} \right] * (1/12)$$

ΣM bottom of compression block

$$= 6,445 \text{ kip-ft}$$

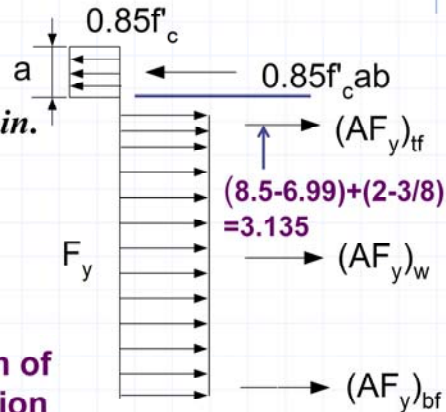

To compute M_p , we need to determine the location of the neutral axis. The neutral axis location is determined as term a equals to C divided by $0.85f'_c b$. This is nothing but an equilibrium check on the cross section. The compression forces must equal to tensile forces, which give us a equal to 7". So the depth of the neutral axis is located 7" from the top of the slab. M_p can be estimated by taking the summation of the moments from the bottom of the compression block. Again the plastic strength of the concrete is $0.85f'_c$ and so this force component equals to $0.85f'_c ab_{eff}$. And then we calculate the forces in the top flange, the web and the bottom flange and take moments about the neutral axis. We can obtain the plastic moment of the composite section by summing up all the moments.

DESIGN EXAMPLE

Member Strength (cont'd)

- ◆ Check ductility (AASHTO Art. 10.50.1.1.2)
 - Prevent concrete crushing

$$\left(\frac{D_p}{D'} \right) \leq 5$$

$$D' = \beta \frac{(d + t_s + t_h)}{7.5}$$

D_p = depth of composite section in compression

$\beta = 0.7$ for $F_y = 50,000$ psi

d = depth of girder

t_s = slab thickness

t_h = haunch thickness above flange

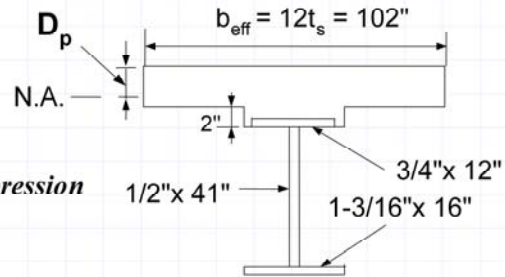

However, when we are calculating plastic capacity of the girder, we are assuming that the concrete can develop compressive strength of $0.85f'_c$ and concrete crushing is going to occur after the steel has yielded. To assure this ductile behavior, a check for ductility must be completed. To prevent concrete crushing, D_p/D' must be less than 5. D_p is the depth of the plastic neutral axis calculated as 6.99", say 7". D' is a cross section characteristic whose definition is given in AASHTO and is calculated in the above expression.

DESIGN EXAMPLE

Member Strength (cont'd)

◆ Check ductility (cont'd)

(Girder + Slab + Haunch + t_f)

$$D' = 0.7 \frac{(42.9375 + 8.5 + 1.25)}{7.5} = 4.92 \text{ in.}$$

$$\left(\frac{D_p}{D'} \right) = \left(\frac{6.99}{4.92} \right) = 1.42 < 5 \quad \text{ok}$$

Steel will yield before
concrete crushes

Steel Strain \gg Concrete

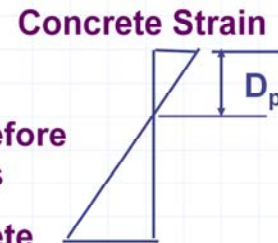

What is D' ? D' is actually the depth of the neutral axis for which the formation of M_p is guaranteed by AASHTO. If the depth of the plastic neutral axis is less than or equal to D' , the section will be able to develop its plastic moment capacity. However, if the depth of the plastic neutral axis is greater than D' , then the moment capacity will not quite get to M_p and will be limited to a value that will be discussed later. Now, the value of D' turns out to be 4.92" and D_p is 6.99" which is greater than D' . D_p/D' is 1.42 which is still less than 5 and therefore a ductile failure is assured. The impact of this ratio on section strength will be discussed later.

DESIGN EXAMPLE

Member Strength (cont'd)

- ◆ Check web slenderness (AASHTO Art.10.50.1.1.2):
 - - Prevent web local buckling

$$\frac{2D_{cp}}{t_w} \leq \frac{19,230}{\sqrt{F_y}}$$

D_{cp} = depth of web in compression at M_p

- In this case, the N.A. at M_p is in the slab and the web is in tension ($D_{cp} = 0$). Therefore, the requirement is automatically satisfied.

Since the location of the neutral axis has been located, we must check the web slenderness. To prevent the local buckling, this is the equation given by AASHTO. D_{cp} is the depth of web in compression at M_p . In this case, the plastic neutral axis lies in the slab and web is in tension. Therefore, this requirement does not need to be checked.

DESIGN EXAMPLE

Member Strength (cont'd)

- ◆ Compute member strength (AASHTO Art. 10.50.1.1.2):

Since $D' < D < 5D'$: **Capacity less than M_p**

$$M_u = \frac{5M_p - 0.85M_y}{4} + \frac{0.85M_y - M_p}{4} \left(\frac{D_p}{D'} \right)$$

$$M_y = F_y S_n$$

*S_n = short term composite section modulus
with respect to tension flange*

Getting back to computing the member strength. The depth of the plastic neutral axis as we calculated is between D' and $5D'$. D' corresponds to the plastic depth where M_p is guaranteed. $5D'$ corresponds to moment capacity of $0.85M_y$. Since our value lies between these two, linear interpolation is used to calculate the ultimate moment capacity. M_y equals to F_y multiplied by S_n .

DESIGN EXAMPLE

Member Strength (cont'd)

◆ Compute member strength (cont'd):

$$M_y = F_y S_n = \frac{50(1,226)}{12} = 5,109 \text{ kip-ft}$$

$$M_u = \frac{5(6,445) - 0.85(5,109)}{4} + \frac{0.85(5,109) - (6,445)}{4} \left(\frac{6.99}{4.92} \right)$$
$$= 6,223 \text{ kip-ft}$$

$$\text{Factored Max. Load Moment} = 5,500 \text{ kip-ft}$$

$$< M_u = 6,810 \text{ kip-ft} \quad \text{ok}$$

$$\text{Ratio} = 0.884$$

Now we can calculate the moment capacity of the section we are designing here. First we calculate M_y and then M_u . Since the depth of the plastic neutral axis is greater than D' , M_u turns out to be 6,223 kip-ft, which is approximately 96 percent of M_p . So the section can not quite get up to M_p because the depth of the neutral axis is greater than D' . The calculated moment capacity is 6,223 kip-ft, which is still greater than the factored load moment of 5,500 kip-ft. The ratio of flexural demand to flexural strength is 0.884.

DESIGN EXAMPLE

Member Strength (cont'd)

◆ Check shear (AASHTO Art. 10.48.8.1):

- Assume an unstiffened web ($k = 5$)

$$V_p = 0.58F_y D t_w = 0.58(50)(41)(0.5) = 594.5 \text{ kips}$$

$$\text{Since } \frac{D}{t_w} = 82 > \frac{7,500\sqrt{k}}{\sqrt{F_y}} = 75 \quad \text{Shear Yield Strength} \\ \text{x Web Area}$$

$$C = \frac{4.5 * 10^7 k}{\left(\frac{D}{t_w}\right)^2 F_y} = \frac{4.5 * 10^7 (5)}{(82)^2 50,000} = 0.669 \quad \text{C=Buckling/Shear} \\ \text{Yield Strength}$$

The next is to check for shear. In order to check for shear, we assume an unstiffened web which implies that $K = 5$. The plastic shear capacity can be calculated as $0.58F_y$ multiplied by depth of the web and multiplied by the thickness of the web. $0.58F_y$ is the shear yield stress derived from the von Mises Criteria. V_p is calculated for this beam to be 594.5 kips. For a D/t_w ratio equal to 82, the ratio of the shear buckling to shear yield strength is computed. We find that shear buckling will govern the strength of the web. It will not develop its yield strength, instead it will undergo shear buckling. Based on the formula for calculating C given by AASHTO specifications, this value turns out to be 0.669. This means that the web will buckle at approximately 67% of the shear yield stress capacity.

DESIGN EXAMPLE

Member Strength (cont'd)

◆ Check shear (cont'd):

$$V_u = CV_p = 0.669(594.5) = 398 \text{ kips}$$

$$\text{Factored Max. Load Shear} = 302.2 \text{ kips}$$

$$< V_u = 398 \text{ kips} \quad \text{ok}$$

$$\text{Ratio} = 0.759$$

*Note : for shear connector design, refer to AASHTO
Article 10.38.5.1.*

V_u is the strength of the beam in shear that is equal to C multiplied by V_p . V_u turns out to be 398 kip and is greater than the factored load shear which is 302.2 kips. The ratio is 0.759. One of the things that we will not go over in this course is the shear connector design. Please refer to AASHTO Article 10.38.5.1. For more information.

DESIGN EXAMPLE

Member Strength (cont'd)

- ◆ Check constructibility (AASHTO Art. 10.61)
 - Check steel girder alone under $1.3 * DL_1$ (before slab hardens)
 - ◆ Web bend buckling (Art. 10.61.1)
 - ◆ Web shear buckling (Art. 10.61.2)
 - ◆ Lateral-torsional buckling of cross section (Art. 10.61.3)
Cross Frames Used to Brace Girders
 - ◆ Top flange local buckling (Art. 10.61.4)
 - Note: calculations will not be illustrated here.

Again the constructibility load calculation will not be illustrated here. However, the constructibility loads are checked for $1.3DL_1$. DL_1 is the non-composite dead load that is the dead load before the concrete deck hardens. The checks that need to be made are web buckling under flexural, web buckling under shear, lateral-torsional buckling of the cross section where the cross frames are used to brace the girders and compression flange local buckling. The calculations will not be illustrated here, but the final numbers are given in the end of this presentation.

DESIGN EXAMPLE

Serviceability Overload Check

◆ Flange Stress from $M_{DL} + 1.67 M_{L(1+I)}$ ie.,
Overload $< 0.95F_y$ for composite sections
(AASHTO Art. 10.57.2)

◆ Bottom Flange Stress =

$$\frac{M_{DL1}}{S_{nc}} + \frac{M_{DL2}}{S_{3n}} + \frac{1.67 M_{L(1+I)}}{S_n}$$
$$= \frac{1,160(12)}{827.6} + \frac{333(12)}{1,136.5} + \frac{1.67(1,641)(12)}{1,226.2} = 47.1 \text{ ksi}$$

Strength Ratio = 0.884 - Yielding $< 0.95(50) = 47.5 \text{ ksi}$ ok
Under Service Load Controls Design **Ratio = 0.992**

We have done the strength check. We have calculated moment capacity and shear capacity and compared them with the required strength. Now we move on to the serviceability checks, the first one being overload. As you remember, there are three serviceability checks we need to do, overload, deflections, and fatigue. The overload check is performed for the bottom flange. The bottom flange stress from the overload must be less than $0.95F_y$ because this is a composite section. The bottom flange stress can be computed using the above expression. The stress is computed as 47.1 ksi which is less than $0.95F_y$ or 47.5 ksi. The ratio is 0.992 which is very close to 1. We have calculated the strength ratio which is 0.884. Now we know that the yielding under the service load controls the design because the overload ratio is 0.992. This is fairly common for steel bridges, the overload check frequently controls a design, not strength under factored loads.

DESIGN EXAMPLE

Serviceability LL+I Deflection Check

- ◆ Deflections from L(1+I) preferably $< L/800$
 - (no pedestrians - AASHTO Art. 10.6.2)

$$\frac{\text{Span}}{800} = \frac{80(12)}{800} = 1.20 \text{ in.}$$

$$DDF = \frac{(2 \text{ wheels/lane}) * (\text{No. of lanes}) * (\text{Multiple lane reduction factor})}{\text{No. of girders}}$$

$$DDF = \frac{2(2)(1.0)}{4} = 1.000 \text{ wheels}$$

The next serviceability check corresponds to the deflections caused by the live load plus the impact. This is an unfactored live load or service load. For service live load, the deflection must be less than the span over 800, which turns out to be 1.2". As previously mentioned, the deflection distribution factor can be calculated by the above expression, which yields a value of 1.0 for this design.

DESIGN EXAMPLE

Serviceability LL+I Deflection Check

◆ For a simple span (truck loading governs):

$$\Delta_{LL} = \frac{324P_T}{EI_n} (L^3 - 555L + 4,780) \text{ at midspan}$$

$$I_n = 4 \text{ girders} * 48,003 \text{ in.}^4 / \text{girder} = 192,012 \text{ in.}^4$$

$$P_T = 4 \text{ front wheels} * 5.0 \text{ kips} / \text{front wheel} * DDF * (1 + I) \\ = 4(5.0)(1.000)(1 + 0.24) = 24.8 \text{ kips} \quad (\text{HS25 Truck})$$

$$\therefore \Delta_{LL} = \frac{324(24.8)}{29,000(192,012)} [(80)^3 - 555(80) + 4,780] = 0.68 \text{ in.}$$

$$< \text{Span} / 800 = 1.20 \text{ in.} \quad \text{ok} \quad \text{Ratio} = 0.569$$

The deflections can be estimated for a simple span using the above expression. I_n is the moment of inertia of the composite section for all the four girders combined. That is 4 multiplied by the moment of inertia of each individual girder. P_T in this expression is the front wheel load. In this case, this is 5 kips because HS25 truck is being used for the design. The live load deflection is calculated to be 0.68" which is less than 1.2" with a ratio of 0.569. So, the second serviceability check is satisfied. The live load deflections is less than span divided by 800.

DESIGN EXAMPLE

Serviceability Fatigue Check

- ◆ Check fatigue at midspan:
 - Assume redundant load path structure
 - Assume Case II roadway (ADTT < 2,500)
 - Use HS20 live loading (plus impact)
 - Check web-to-bottom flange fillet weld (Category B - see AASHTO Table 10.3.1B)
 - Check cross-frame connection plate weld to bottom (tension) flange (Category C)

The third serviceability check corresponds to fatigue. We need to check the fatigue at mid span for a redundant load path structure. We also assume Case II roadway which corresponds to annual daily truck traffic of less than 2,500. We have been using HS25 as live load for designing this beam. However, for fatigue, HS20 is the specified design load. We need to check two typical fillet welds in this construction. The web-to-bottom flange fillet weld which is a Category B weld according to the AASHTO specifications, and cross-frame connection plate weld to bottom flange which is a Category C weld.

Fatigue Details

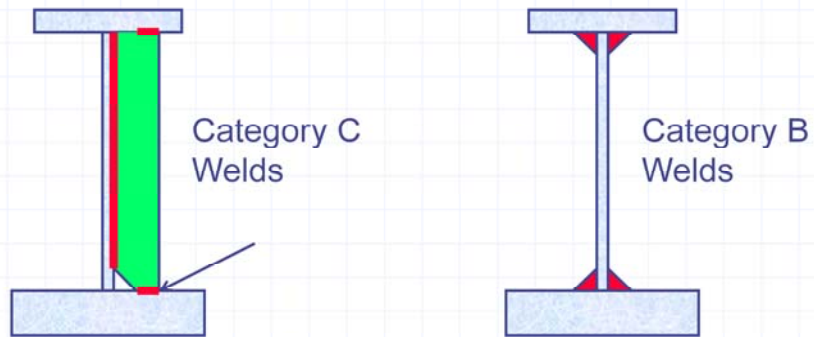

These are the pictures of those two welds. One is Category C weld and the other is Category B weld. Both welds are located adjacent to the tension flange. Because the tension flange is subjected to a stress range due to live loads, those welds are also subjected to the stress range when trucks pass over the beam. The fatigue life of those connections must be greater than the demands on the beam.

DESIGN EXAMPLE

Serviceability Fatigue Check (cont'd)

- ◆ For a Case II roadway, check for 500,000 cycles of truck loading and 100,000 cycles of lane loading (AASHTO Table 10.3.2A).

Allowable Fatigue Stress Range, Fsr, kips
(AASHTO Table 10.3.1A)

	<u>Category B</u>	<u>Category C</u>
500,000 cycles	29	21
100,000 cycles	49	35.5

For a Case II roadway, we need to check for 500,000 cycles of truck loading and 100,000 cycles of lane loading per AASHTO Specifications for Case II roadway. Allowable fatigue stress range for Category B detail for 500,000 cycles of truck loading is 29 ksi. For Category C detail and for 500,000 cycles of truck loading, the fatigue stress range is 21 ksi. These numbers are tabulated in AASHTO. For 100,000 cycles of lane loading, the category B detail has an allowable fatigue stress range of 49 ksi and category C detail has an allowable fatigue stress range of 35.5 ksi.

DESIGN EXAMPLE

Serviceability Fatigue Check (cont'd)

◆ For HS20 live loading plus impact (at midspan):

- $+M_{L(1+I)}$ (truck) = 1,313 kip-ft
- $+M_{L(1+I)}$ (lane) = 986 kip-ft
- $S_n = 1,265 \text{ in.}^3$ (to bottom of web)

◆ For a simple span, the live-load (plus impact) stress range is:

$$f_{sr} = \frac{+M_{L(1+I)} + 0.0}{S_n}$$

Since we are using HS20 truck loading plus impact for the fatigue design, the live load moments are 80% of what we have calculated previously for HS25 truck. The live load moment of truck loading turns out to be 1,313 kip-ft. And for the lane loading, it is 986 kip-ft. We need to calculate both the truck and the lane loading because we are going to check 500,000 cycles of truck loading and 100,000 cycles of lane loading. S_n is the section modulus of the composite section to the bottom of the web. This is where both welds are located and where we are trying to check for the fatigue. The section modulus is 1,265 in³ for that case. So, for the simple span the live load plus impact stress range can be calculated as the live load moment due to fatigue loading divided by S_n .

DESIGN EXAMPLE

Serviceability Fatigue Check (cont'd)

- ◆ The calculated live-load (plus impact) stress ranges at the bottom of the web are as follows:

$$f_{sr} = \frac{1,313(12) + 0.0}{1,265} (\text{truck}) = 12.46 \text{ ksi} < F_{sr} = 29 \text{ ksi (Cat.B)} \quad \text{ok} \quad \text{Ratio} = 0.429$$

$$< F_{sr} = 21 \text{ ksi (Cat.C)} \quad \text{ok} \quad \text{Ratio} = 0.593$$

$$f_{sr} = \frac{986(12) + 0.0}{1,265} (\text{lane}) = 9.36 \text{ ksi} < F_{sr} = 49 \text{ ksi (Cat.B)} \quad \text{ok} \quad \text{Ratio} = 0.191$$

$$< F_{sr} = 35.5 \text{ ksi (Cat.C)} \quad \text{ok} \quad \text{Ratio} = 0.264$$

The calculated live load plus impact stress ranges at bottom of the web are found as follows. The stress range for truck loading is 12.46 ksi. It turns out that the allowable for Category B is 29 ksi, so the design is OK. For Category C detail, the allowable is 21 ksi, so the fatigue check is fine as well. The ratios are 0.429 and 0.593. For lane loading, the stress range calculated is 9.36 ksi. However, for Category B detail the allowable is 49 ksi and for Category C detail the allowable is 35.5. We can conclude from the low ratios of actual to allowable stress that load induced fatigue is not a significant concern for this bridge.

DESIGN EXAMPLE - SUMMARY

	<u>Ratio</u>
◆ Safety	
■ Bending strength (Maximum Load)	0.884
■ Shear strength (unstiffened web)	0.759
◆ Serviceability	
■ - Permanent deflections (Overload)	0.992
■ - Live load deflections (Service Load)	0.569
■ - Fatigue (web-to- flange weld - trk.)	0.429
■ - Fatigue (connection-plate weld - trk.)	0.593

Now we can summarize the design example. We were illustrating the AASHTO Load Factor design principles for a short span steel bridge. The span was chose to be 80 ft and the design was composite with a concrete deck. Calculations for strength and serviceability limits were prepared. From the strength stand point as far as the bending strength is concerned, the ratio of applied force to capacity was 0.884 and for shear the ratio was 0.759. From the serviceability stand point, three checks were made. One was overload, the second was deflection and the third was fatigue. For the overload check, the ratio was 0.992. This easily governs the design of the beam for this example. For live load deflections, the ratio turned out to be 0.569. As far as fatigue is concerned, for truck loading and for the web-to-flange weld, the ratio turned out to be 0.429. And for the connection-plate weld under truck loading, the ratio was 0.593.

DESIGN EXAMPLE - SUMMARY (CONT'D)

- ◆ Constructibility (checked separately) **Ratio**
 - - Web bend buckling 0.629
 - - Lateral-torsional buckling of cross sect. 0.648
 - - Top flange local buckling 0.655
- ◆ The design is controlled by the permanent deflection limit state (Overload).
- ◆ Weight of structural steel = 18.3 psf of deck area

Constructibility, which was not looked into in details here, was checked separately. The ratios for web bend buckling, lateral-torsional buckling of the cross section and local buckling of the top flange were found to be 0.629, 0.648 and 0.655 respectively. As a summary, the design was controlled by the permanent deflection limit state corresponding to an overload truck passing over the bridge. We found that the design weight of the structural steel was 18.3 psf of the deck area, very similar to our estimated weight. This completes the design example, in which the AASHTO load factor design method was utilized to check strength and serviceability of a short span steel bridge.