



**PDHonline Course C192 (3 PDH)**

---

# **Subsurface Barriers for Contaminated Sites**

*Instructor: John Huang, Ph.D., PE and John Poullain, PE*

**2020**

**PDH Online | PDH Center**

5272 Meadow Estates Drive  
Fairfax, VA 22030-6658  
Phone: 703-988-0088  
[www.PDHonline.com](http://www.PDHonline.com)

An Approved Continuing Education Provider

## APPENDIX B: VERTICAL BARRIER WALL DESIGN CONSIDERATIONS FOR HAZARDOUS WASTE CONTAINMENT APPLICATIONS

### B-1. General

*a. Intended use of document.* This document for vertical barrier wall design was developed to aid in project planning, scheduling, and budgeting; scoping predesign investigations and architect/engineer (A/E) services; as a guidance document for conducting vertical barrier wall designs; reviewing A/E products; and as a source for technical references. The document is divided into three appendices: Appendix A, References; Appendix B, Design Considerations; and Appendix C, Checklist. Appendix B briefly discusses design aspects for vertical barrier wall components. Appendix C contains a list of questions covering pertinent aspects of design that were discussed in Appendix B.

*b. Purpose and function of vertical barriers.* The primary purpose of a vertical barrier wall is to isolate hazardous waste contamination by minimizing the movement of groundwater from a contaminated site to uncontaminated areas or by preventing clean groundwater from entering a contaminated area. Vertical barrier walls function as a relatively impermeable barrier which either contains or redirects groundwater flow.

*c. Types of vertical barriers.* The type of vertical barrier wall chosen for use at a hazardous waste site is dependent on environmental and site-specific parameters. No Environmental Protection Agency (EPA) regulations exist for the design and construction of vertical barrier walls. The type of vertical barrier wall most commonly used at hazardous waste sites is the soil-bentonite (S-B) slurry wall. EPA-540/2-84-001 provides guidance on the design and construction of S-B slurry walls. This document will focus on design issues for S-B slurry walls; however, several other types of walls will also be discussed.

*d. Project team.* An idealized design/review team for a vertical barrier wall project is provided below. For most projects, the design or review team will not include individuals from each of the noted disciplines. Consequently, it is important that all aspects of design are assigned to a member of the team. Team members include:

- a Customer.
- a Project manager.
- a Technical manager.
- a Project engineer.
- a Geotechnical engineer.
- a Geologist.
- a Mechanical engineer.
- a Electrical engineer.
- a Hydrologist.
- a Environmental engineer.
- a Civil engineer.
- a Industrial hygienist.
- a Chemist.
- a Land surveyor.
- a Landscape architect.
- a Drafter/computer-aided design and drafting (CADD) technician.
- a Specifications writer.
- a Cost estimator.
- a Regulatory specialist.
- a Real estate specialist.
- a Construction representative.
- a Local, state, and Federal regulatory staff.

## B-2. Predesign Investigations

*a. General.* Prior to preparing a design analysis or plans and specifications for any type of vertical barrier wall, it is necessary to conduct predesign surveys and investigations to fill data gaps. The existing database available from the remedial investigation (RI), feasibility study (FS), and other documents must be reviewed before scoping a predesign effort. The following information is often required in the design of a vertical barrier wall.

*b. Field surveys and record searches.*

(1) Aerial photography. Historic aerial photographs can be used to preliminarily define the nature and extent of contamination at a site. The principal sources of aerial photographs are the U.S. Department of Agriculture (USDA) Agricultural Stabilization and Conservation Service (ASCS) and the U.S. Geological Survey (USGS).

(2) Design and operational data. Design and operational information such as as-built drawings, specifications, and design analyses may help in identifying the nature and extent of contamination. However, documents such as these are rarely available for hazardous waste sites.

(3) Map database. The USGS, USDA, and other government agencies produce topographic, soils, groundwater, and other mapping that may be useful in the design of a vertical barrier wall.

(4) Topographic surveys. A current topographic survey of the site is required. To allow for manipulation of data and to expedite the design process, the topographic survey should be mapped on a computer aided design and drafting (CADD) system. Ideally, topographic mapping will have 300 mm (1 ft) contour intervals. However, larger contour intervals may be acceptable depending on site-specific conditions (e.g., time, budget, and topography). Topographic mapping should be accurate to within  $\pm 30.0$  mm ( $\pm 0.1$  ft) in the vertical and horizontal directions. Elevations of piezometers, monitoring wells, or other instrumentation should be accurate to  $\pm 3.0$  mm ( $\pm 0.01$  ft) to allow for accurate interpretation of data. All surface features such as buildings, utilities, ponds, fences, trees, streams, ditches, and exploratory borings and trenches should be delineated on the mapping.

(5) Horizontal and vertical control. At a minimum, three permanent control monuments need to be established. The monuments should be strategically located so that they are not damaged during construction. All monuments should be assigned state plane coordinates and/or tied into the horizontal grid used in previous studies. The vertical datum should be mean sea level, North American Datum of 1983.

(6) Monitoring baseline survey. To monitor design concerns, it is necessary to perform surveys to establish a baseline for monitoring wells, piezometers, and other instrumentation.

(7) Utilities. All onsite above and below ground utilities should be identified, located, and subsequently shown on the project drawings. A utility search should consist of an onsite inspection, review of as-built drawings, and contacts with utility companies. The project drawings should show the location of onsite utilities including horizontal alignment, depth or height, type, and size.

(8) Boundary survey and property search. A boundary survey should be performed for all properties or parcels within project construction or access limits. The boundary survey should be tied to the site's horizontal control. A property search should also be performed to identify property owners of all affected and adjacent parcels of land. Prior to any investigation or construction activity, it is essential to obtain construction easements and project rights-of-way. This may take 12 to 18 months; therefore, coordination with real estate specialists should begin as soon as possible.

*c. Geological investigations.* After the existing database has been reviewed, geological investigations can be scoped. The following items need to be investigated in order to design a vertical barrier wall system.

(1) Limits of waste. The limits of the contaminated area the vertical barrier wall will surround need to be defined. Depending on the type and composition of the waste, the limits can be tentatively defined by geophysical methods such as electromagnetic conductivity surveys and soil gas surveys. Intrusive methods such as test pits, borings, and monitoring wells will also need to be used to verify the boundaries of the contaminated area. All test pits and

borings should be logged by a qualified geologist or geotechnical engineer. Surveys should also be performed to determine the exact location of any geotechnical investigations used to define the boundary of the contaminated area.

(2) Site geology. The subsurface geologic conditions must be determined and understood prior to design and construction of a vertical barrier wall. Some of the geologic data which may be required for design include detailed site stratigraphy, soil or rock type, grain size distribution, Atterberg limits, moisture content, chemical properties of the aquifer materials, degree of weathering, structural discontinuities, rock hardness, and ripability.

(3) Hydrology. In addition to understanding the geology, it is imperative to have an understanding of the site groundwater conditions to define pollution migration paths. The types of hydrologic information typically required for design include the following: location of the water table, recharge and discharge zones, hydraulic head distribution, hydraulic conductivity, porosity, extent of geologic units, contaminants present in the groundwater, and background water quality. After data gathering has been accomplished, potentiometric surface maps, geologic cross-sections with water table elevations, and the depth and extent of the slurry wall can be determined. A groundwater model can be used to evaluate and simulate future groundwater conditions, and several vertical barrier wall alignments can then be evaluated by the model.

*d. Chemical data requirements.* Chemical testing is often required for the features listed below. A chemist should be involved in these aspects of the project.

- (1) Leachate and groundwater testing.
- (2) Determination of limits of waste.
- (3) Contaminated materials handling.
- (4) Compatibility testing of vertical barrier wall materials and site contaminants.
- (5) Borrow soil testing (contamination check).

### B-3. S-B Slurry Walls

*a. History and background.* A S-B slurry wall (Figure 1), constructed by the slurry trenching technique, is a subsurface barrier made to impede or redirect the flow of groundwater. This technique was pioneered in the United States in the mid-1940's using technology developed by the oil industry. Slurry wall construction is a versatile technique that has been used extensively for cutoff walls in dams and levees, and is very successful in controlling pollutants, contaminated groundwater, and landfill leachate migrating from waste sites. Because they have been so successful, the use of slurry walls has largely replaced the use of traditional cutoff barriers such as steel sheet pile walls and grout curtain walls at hazardous waste sites.

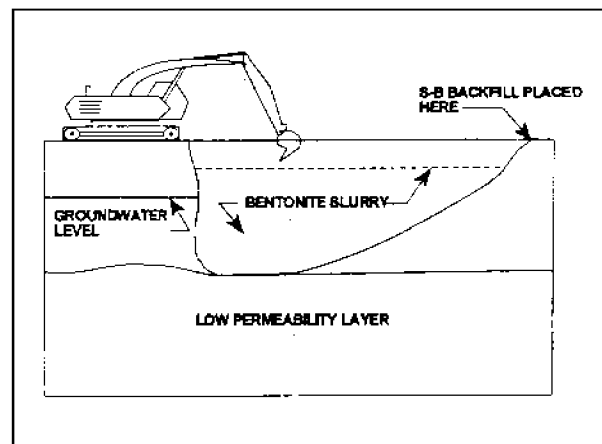

**Figure 1. Slurry wall schematic**

*b. General construction.* A S-B slurry wall is constructed by excavating a narrow vertical trench, typically 600 to 1,500 mm (2 to 5 ft) wide, through pervious soils to a relatively impervious key stratum. During excavation, the trench is filled with slurry consisting of a bentonite and water mixture. The trench is kept full of slurry to prevent the trench walls from caving or sloughing. The slurry also develops a filter cake on the walls of the trench that contributes to trench stability and to the low permeability of the completed cutoff wall. Slurry trenches have been excavated to depths of more than 30 m (100 ft) with no caving or sloughing of the trench

walls. Depending on the depth of the trench, typical excavation equipment may include extended reach backhoes, clamshells, or draglines. For depths less than about 20 m (70 ft), backhoes are generally most efficient. After excavation, the slurry filled trench is backfilled with a soil/bentonite/water mixture engineered to create a low-permeability cutoff wall (1  $\square$  10<sup>-7</sup> cm/sec to 1  $\square$  10<sup>-8</sup> cm/sec). U.S. Army Corps of Engineers (USACE) guide specification CEGS 02444, Soil-Bentonite Slurry Trench for HTRW Projects, should be used in the preparation of plans and specifications for S-B slurry walls.

*c. Predesign issues.*

(1) Geologic subsurface investigation. A slurry wall should be keyed into an impervious geologic formation along the entire length in order to avoid potential seepage zones under the wall. Borings are taken along the proposed alignment of a slurry wall, preferably before the development of plans and specifications. These borings are spaced 30 to 60 m (100 to 200 ft) apart, depending on the geologic uniformity and thickness of the key layer. Additional borings may be taken along the alignment during slurry wall construction to verify assumptions made during design. During the design phase, samples can be taken from the slurry wall alignment borings for use in backfill optimization and compatibility studies. In addition, groundwater levels should be measured along the alignment of the slurry wall, and if possible, seasonal groundwater fluctuations should be documented.

(2) Soil-bentonite (S-B) backfill testing and optimization.

(a) Borrow sources. During predesign investigations, potential borrow sources for backfill material should be located and sampled. Soils excavated from the trench may be utilized for backfill soil. This practice saves the time and money of locating, purchasing, and hauling borrow soil to the site. It also eliminates the problem of disposing of the excavated trench material. If the in situ soils are not suitable, due to problems with gradation or gross contamination, imported borrow is the only viable option. Soil characteristics such as classification, gradation, water content, permeability, and chemical properties should also be evaluated. If a single borrow area does not have a suitable soil, it may be necessary to mix two different soils to come up with suitable backfill material.

(b) Backfill soil materials. To obtain a low permeability (typically 1  $\square$  10<sup>-7</sup> cm/sec or less) S-B backfill mixture, soils with an appreciable amount of fines (preferably plastic) are necessary. USACE guide specification CEGS 02444 provides the following gradation criteria for backfill soils:

<u>Screen Size or Number</u> <u>(U.S. Standard)</u>	<u>Percent Passing</u> <u>by Dry Weight</u>
75 mm (3 in.)	100
4.76 mm (No. 4)	40-80
0.42 mm (No. 40)	25-60
74 $\mu$ M (No. 200)	20-40

(c) Bentonite. Bentonite is a natural clay whose principal mineral constituent is sodium montmorillonite and is characterized by a very large volume increase with wetting. Bentonites which conform to Section 4 of API Spec 13A typically have been treated with small amounts of polymers. Bentonites which conform to Section 5 of API Spec 13A have not been chemically treated. Nontreated (Section 5) bentonites are generally more expensive than Section 4 bentonites. Bentonites conforming to Section 4 may be used for construction, provided the necessary permeability is obtained during compatibility testing; however, bentonite which conforms to Section 5 of API Spec 13A is generally preferred. During predesign, several types of bentonite from various suppliers should be obtained for compatibility and backfill optimization testing. USACE guide specification CEGS-02444 requires the following properties for bentonite used for slurry wall construction:

YP/PV Ratio	API Spec 13A	<3
Viscometer		>30
Filtrate Loss		<15 cm <sup>3</sup>
Moisture Content	ASTM D 2216	<10 percent

(d) Water. During pre-design activities, samples of the groundwater and samples of tap water to be used for slurry mixing and other operations should be obtained. Generally, 40 liters (10 gallons) of each should be obtained for compatibility and backfill optimization testing. Since a large volume of water is normally required for any slurry trench installation, an adequate source of mixing water must be identified. The guide specification requires water used for mixing slurry and backfill meet the following requirements:

pH	API RP 13B-1	6 to 8
Hardness		<200 ppm
Total dissolved solids		<500 ppm
Oil, organics, acids, alkali, and other deleterious substances		<50 ppm each
Chloride	ASTM D 512	For Record

(e) Bentonite slurry mixture. Once all bentonite and water samples are obtained, the design of the bentonite slurry mixture may begin. In general, a bentonite content of 6 percent by weight should meet most requirements. The EPA recommends the following properties for bentonite slurries: viscosity (measured with a Marsh funnel) greater than 40 sec, unit weight around 1,025 kg/m<sup>3</sup> (65 pcf), pH between 7 and 10, and a bentonite content of 4 to 8 percent. USACE guide specification CEGS-02444 states that the bentonite slurry should meet the following criteria:

Viscosity	API RP 13B-1	>40 sec
Density		>1025 kg/m <sup>3</sup> (64 pcf)
Filtrate loss		<20 cm <sup>3</sup>
pH		6.5 to 10

(f) Initial compatibility testing. The presence of chemical contaminants in soil and/or groundwater may significantly alter the rate of water movement through a S-B slurry wall. For example, calcium in soil or groundwater will displace some of the sodium ions in bentonite. This results in reduced swelling of the bentonite and increased permeability. While the effects of individual chemicals on S-B slurry walls have been studied and documented, the effects of multiple contaminants, which are common at most HTRW sites, are largely unknown. The objective of any compatibility/optimization testing is to determine the optimum S-B backfill mix design necessary to achieve an in-place permeability of 1 × 10<sup>7</sup> cm/sec or less. In addition, the study should determine whether contaminants present in the soil or groundwater will cause long-term changes to the S-B backfill. Typically, a compatibility testing program will last 3 months or longer. Because of the long time frame involved, it is often preferable to conduct preliminary compatibility tests during the predesign phase and long-term compatibility tests concurrent with design.

A recommended compatibility testing program generally consists of the following:

The free swell test measures the increase in volume of a bentonite sample when poured into water. Free swell is expressed as a percentage of the original (dry) volume. Two grams (2.2 cm<sup>3</sup>) of bentonite are slowly poured into 100 ml of water and the volume of settled solids is recorded after 2 and 24 hr. See United States Pharmacopeia test method USP-NF-XVII for a test description. Often, two tests are conducted, one using tap water from the site and the other using contaminated groundwater from the site. Several bentonites should be evaluated and the results of the free swell tests used in the selection of a bentonite. Bentonite samples which exhibit the greatest swell and are the least affected by contaminants are usually chosen for use in the remainder of the compatibility testing.

Another test which is often run to help determine bentonite selection is the Filter Cake Compatibility Test. As stated previously, the filter cake is an important component of an S-B slurry wall. Filter cake permeabilities may be as low as 1 × 10<sup>9</sup> cm/sec. For this reason, both filter cake compatibility tests and free swell tests are used to evaluate bentonite performance. Bentonite slurry (6 percent bentonite by weight and site tap water) from each potential bentonite source is placed in a fixed-wall permeameter. Slurry is then forced through filter paper overlying a porous stone at the bottom of the chamber with a chamber pressure of about 7 N/cm<sup>2</sup> (10 psi) for 24 hr. During this time, a filter cake of approximately 10 mm (1/2 in.) thick will form on the filter paper. The remaining bentonite slurry is then removed and replaced with either site tap water or contaminated groundwater. The water is forced through the filter cake with a pressure of about 1 to 2 N/cm<sup>2</sup> (2 to 3 psi). Permeabilities are calculated and plotted for a 48-to 72-hr period. Bentonites which exhibit the least variation between tap water and groundwater should be considered for use. At the conclusion of the free swell tests and the filter cake compatibility tests, one bentonite is chosen for the remainder of the compatibility testing.

(g) Mix design optimization. The purpose of this phase of testing is to determine the most economical mix of soil, dry bentonite, and bentonite slurry which will produce an in-place slurry trench permeability less than or equal to 1 × 10<sup>7</sup> cm/sec. Because mixing and placing operations are less

controlled in the field than in the laboratory, it is prudent to attempt to achieve a maximum laboratory permeability of  $5 \times 10^{-8}$  cm/sec or less. Laboratory test equipment must be constructed of materials that are chemically resistant to the groundwater contaminants. Short-term permeability tests (48 to 72 hr) using fixed-wall or flexible-wall permeameters are run on various mix designs, varying the amount of dry bentonite added (i.e., 0, 2, and 4 percent). Samples to be tested should be mixed to achieve a 100- to 150-mm (4- to 6-in.) slump. One sample should be run with site tap water as the permeant (control sample), and one sample should be run with contaminated groundwater as the permeant. It should be noted that when using fixed wall permeameters, the specimen should be allowed to set up and then applied head pressures should be increased slowly over several days, to avoid a sample failure. The most economical S-B backfill which achieves a permeability less than or equal to  $5 \times 10^{-8}$  cm/sec, should be selected for subsequent long-term testing.

(h) Long-term compatibility tests. Long-term compatibility testing consists of running flexible wall permeameter tests on a minimum of three S-B backfill material samples utilizing the optimum mix design obtained during short-term permeameter testing. One sample should be run with site tap water only as the permeant (control sample); one sample with contaminated groundwater as the permeant (after one pore volume of site tap water permeant); and one sample with a bentonite content 2 percent greater than the optimum mix design, with contaminated groundwater as the permeant (after one pore volume of site tap water permeant). It is generally recommended that three pore volumes of groundwater pass through the S-B backfill material. This testing may take up to 3 months, depending on the sample size. It is recommended that the height-to-width ratio of the sample not exceed 1:1. For example, a 75 mm (3 in.) diam sample should not be longer than 75 mm (3 in.). It is also recommended that inflow and outflow measurements be taken during long-term tests to ensure that no leakage is in the system. A chemical analysis is often run on the effluent that has run through the samples to see if any changes have occurred in the permeant. This data may be used to determine a long-term effect of contaminants on a soil-bentonite mixture. For example, an increase in the amount of sodium and a decrease in the amount of calcium in the permeameter effluent may indicate a displacement of sodium ions in the bentonite by calcium ions in the groundwater. This reaction may tend to increase the

permeability of the S-B backfill over time. After long-term compatibility tests are completed, the results are then analyzed to determine if the contaminants present in the groundwater have increased the permeability of the S-B backfill in comparison to the control sample.

*d. Geotechnical design.*

(1) Slurry wall alignment. Based on predesign investigations, a slurry wall is often located so that it surrounds a contaminated groundwater plume, or a localized "hot spot". Sometimes a slurry wall may be installed to prevent clean groundwater from entering a site. Because of health and safety considerations during construction, it is desirable to locate the slurry wall outside the area of gross contamination. The handling and stockpiling of contaminated materials excavated from a slurry trench is also expensive. When practical, in order to maintain a continuous slurry wall, it is desirable to round corners of a slurry trench rather than to intersect two straight line segments. Although depth dependent, a 30-m (100-ft) radius curve is usually the shortest radius that most excavation equipment can negotiate.

(2) Key depth.

(a) One of the most important elements in a slurry wall design is determining if there is an adequate "key" into which the slurry wall can be tied. Usually, a slurry wall is keyed into a soil or rock horizon which performs as an aquiclude. When the key material is a soil, the slurry trench should be keyed a minimum of 600 mm (2 ft) into the confining layer. If the key material is rock, the nature of the rock surface must be determined throughout the alignment of the wall. The wall must extend through areas of broken and/or weathered material into essentially impermeable material in order to minimize seepage along the contact. Some options to remove weathered rock may include mechanical removal, controlled blasting, and debris removal with airlift equipment. See ETL 1110-2-282 for more information on rock excavation. Grouting along the contact may be feasible in some instances; however, grouting of bedrock will greatly increase construction costs and may create new seepage fractures in the rock formation or the S-B backfill.

(b) For floating contaminants such as oil products leaked from fuel storage tanks, it may not be

necessary to key into some low permeability layer. These slurry walls are termed "anchored slurry walls."

(3) Wall thickness. When designing the thickness of the wall, the hydrostatic gradient and the permeability of the backfill material must be evaluated. A wall thickness of 900 mm (3 ft) will meet most design criteria, although walls up to 2 m (7.5 ft) in width have been constructed. Also, a thicker wall will provide a greater margin of safety if inconsistencies exist in the backfill. It is also desirable that the trench be excavated with one pass of the excavation equipment.

(4) Work platform. If the terrain is highly irregular, has steep slopes, or dense vegetation, extensive site work and grading will be necessary. A S-B slurry wall generally cannot be constructed in areas with a slope greater than 2 percent along the alignment of the slurry wall, unless site grading can be performed or a work platform is constructed to maintain this slope restriction. The width of the work platform must be adequate for the equipment envisioned for construction. A work platform width of 12 m (40 ft) with the slurry trench located along the centerline is typically specified (Figure 2). Wider platforms may be needed if S-B backfill will be mixed alongside the trench. Materials to construct the work platform should exhibit good compaction characteristics to provide a firm working surface.

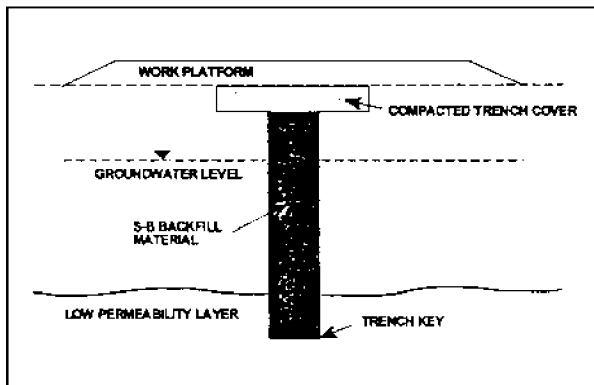

Figure 2. Typical slurry trench cross section

(5) Trench stability. While the slurry trench method generally provides adequate trench stability, some soils that are extremely loose must be analyzed to verify the trench will remain stable during construction. Other construction control practices such as stockpile locations and equipment operation near

the trench should be specified to maximize trench stability.

(6) Control of groundwater. The control of groundwater is an integral part of any vertical barrier wall design. To provide positive contaminant containment, groundwater is often extracted from the inside of a barrier wall to provide an inward hydraulic gradient from the outside of the wall to the inside. Thus, contaminants in the groundwater may be effectively contained, since any wall leakage will be inward rather than outward.

(7) Site layout. In general, slurry wall construction requires a great deal of relatively flat, open space to provide room for equipment, slurry hydration ponds, and S-B backfill mixing areas. Mixing areas should be located as near the trench as possible, with adequate utilities available.

(8) Construction quality control. As with any construction project, the preparation of the finest plans and specifications does not guarantee the installation of a quality product. Construction quality control for slurry walls is of utmost importance if a slurry wall is to function as designed. The following items are considered to be fundamental to ensuring a quality slurry wall installation:

(a) Contractor qualifications. It is imperative that the slurry wall contractor have the necessary experience and qualifications to do the work. Perhaps the two most important individuals involved in the construction of a slurry wall are the slurry trench specialist, and the excavation equipment operator. Submittals should be provided for both of these individuals, prior to construction, showing that they meet the experience requirements outlined in the specifications. The Contractor should also submit, prior to construction, all required plans which describe how the work will be done. The plans should include four items: sequence and layout of operations; trenching operations plan (includes trench excavation, use of excavated material, trench bottom cleaning, backfill placement, etc.); preconstruction backfill testing procedures and results; and quality control sampling and testing plan.

(b) Bentonite. The Contractor should submit a bentonite sample and test results from the bentonite manufacturer for each lot of bentonite. The bentonite



must meet all specified requirements and be stored in a proper manner on site.

(c) Water. The water must meet all specified requirements. The Contractor should be required to condition the water or locate another source if the specified requirements are not met.

(d) Bentonite slurry. The initial bentonite slurry must be tested prior to placement in the trench to ensure that all required properties are met. Bentonite may be mixed in high-shear mixers or mixed and hydrated in slurry hydration ponds. In general, a minimum hydration time of 8 hr will allow the bentonite slurry to meet all criteria. Other tests, such as viscosity, density, and pH, should be run two times each shift per batching plant during construction. Slurry in the trench should be tested for viscosity, density, sand content, and pH two times each shift, at two locations in the trench (approximately 600 mm (2 ft) below the slurry surface and 600 mm (2 ft) above the bottom of the trench.)

Bentonite slurry should be introduced into the trench when excavation begins. The slurry level in open trenches should be maintained at a minimum of 1 m (3 ft) above the groundwater level, and no more than 600 mm (2 ft) below the top of the working platform. If the density of the slurry in the trench exceeds  $1,025 \text{ kg/m}^3$  (85 pcf), the excess solids must be removed or the slurry must be replaced with fresh slurry. If the excess solids are not removed, they may settle to the bottom of the trench, creating areas of higher permeability within the wall.

(e) S-B backfill material. Mixing S-B backfill materials should be done in such a manner that the S-B backfill is consistent. Generally, S-B backfill materials are mixed either on a separate mixing pad or alongside the slurry trench. It is felt by many that it is easier to control S-B backfill mixing when done on a separate mixing pad. However, mixing on a separate pad requires extra handling of materials and is generally more expensive. It is important that all soil particles are coated with slurry and that clods are broken down. Quality control test results for permeability, slump, density, and moisture content should be supplied by the Contractor as required in the specifications for the S-B backfill.

(f) Trench excavation. The upgradient portion of the slurry wall is generally constructed first. Constructing the down gradient portion of the wall first

can make construction more difficult by causing the groundwater elevation to rise in areas where the wall has not yet been built. The critical aspect of trench excavation is ensuring that a proper key layer has been excavated into the confining layer. Most often, it is relatively easy to determine when the key layer has been reached based upon bucket cuttings. However, if the key layer is difficult to determine from bucket cuttings, it may be necessary to push drive samplers to obtain samples. Once S-B backfilling operations have begun, it is recommended that trench excavation precede the toe of the S-B backfill slope by at least 9 m (30 ft), but not more than 30 m (100 ft). This practice will decrease the length of open trench filled with slurry, decreasing the risk for caving or sloughing of the trench walls. It is preferable to round the corners of a slurry trench rather than have intersecting walls. This practice will allow S-B backfill materials to flow around the curve. Material excavated from the trench should be stockpiled as far as practical away from the trench. If the excavated trench spoils produce odors, it may be necessary to cover the stockpiles. During excavation, soundings should be obtained to determine the elevation of the top of the key layer, the bottom of the excavation, and the bottom of the trench prior to backfilling. If excessive sediments (greater than 50 mm (2 in.)) have built up, it will be necessary to clean the trench bottom by airlift pumps, or excavation equipment, to remove the sand and sediment that has settled to the bottom of the trench. The trench bottom should be cleaned, as a minimum, at the beginning of each shift. The soundings should be obtained approximately every 6 m (20 ft) along the alignment of the trench.

(g) S-B backfill placement. Initial S-B backfill placement should be performed by one of the following two methods: placement by lowering S-B backfill to the bottom of the trench with a crane and clamshell bucket or tremie until the surface of the S-B backfill rises above the surface of the slurry or, begin excavation at a point outside the limits of work to allow a S-B backfill face to form prior to reaching the full depth of the required slurry trench. S-B backfill should be placed so that no pockets of slurry are trapped. Free dropping of S-B backfill is not permitted. It should be placed on top of the previously placed S-B backfill and allowed to push out along the bottom of the trench, or slide down the forward face of the S-B backfill slope. Periodic soundings should be taken along the face of the slope

to ensure that a smooth face has formed and is maintained.

(h) Post-construction testing. Long-term performance of the slurry wall is primarily determined by monitoring wells. Once S-B backfill material is placed, it is very difficult to detect voids that may be present in the slurry wall. Various techniques have been attempted to determine if voids are present. One method is to take Shelby tube samples of the completed wall. However, it is often difficult to obtain good samples and is generally expensive. Pump tests may also provide some indication of the performance of the wall.

(9) Slurry wall protection.

(a) Clay plug. In order to protect the completed slurry wall from desiccation, a temporary noncompacted soil cover is placed over the S-B backfill. Usually, this temporary soil cover is placed within 1 day after S-B backfill is completed, over each 30 m (100 ft) reach. After allowing for settlement (approximately 2 weeks), the temporary soil cover should be removed, and replaced with a compacted clay cover over the completed slurry wall. The dimensions of the final clay plug are site specific.

(b) Equipment crossings. During construction, it may be necessary to construct equipment crossings over the completed wall. Measures should be taken during construction to minimize the number of equipment crossings at the site. For heavy equipment, it is recommended that the upper portion of (depth varies with the width of the trench) the S-B backfill be excavated and a clay plug be placed under the compacted trench cover and equipment crossing. Various geosynthetic materials may also be used to help bridge the soft S-B backfill.

(10) Instrumentation.

(a) Monitoring wells. Monitoring wells should be installed to monitor the performance of the slurry wall. Monitoring wells should be spaced evenly on both sides of the slurry wall. Groundwater and contaminant levels should be recorded at regular intervals, at a frequency determined by the design of the cutoff wall and the regulatory authorities. Periodic maintenance of the monitoring wells may be necessary to ensure proper operation.

(b) Settlement. Settlement monuments may be required at slurry wall installations which are very deep (>15 m (50 ft)) or have a thick wall (>1,200 mm (4 ft)). Most settlement will occur during the first year after installation.

#### B-4. Alternative Barrier Systems

a. *Cement-bentonite slurry walls.*

(1) Description. A cement-bentonite (C-B) slurry wall is similar to a S-B slurry wall, except that cement is added to the trench slurry in order to produce a self-hardening slurry, thus eliminating the need to backfill the trench. C-B slurries normally contain water with about 6 percent by weight bentonite and 18 to 30 percent cement. After hardening, C-B walls generally have strengths from about 14 to 35 N/cm<sup>2</sup> (20 to 50 psi). The permeability of a C-B slurry wall is generally around  $1 \times 10^6$  cm/sec. It should be noted that the permeability of C-B walls may decrease over time, and that measurements taken at 28 days may underestimate long-term permeabilities.

(2) Applicability. The C-B slurry wall method is best suited to contain sites with hydrocarbon contamination. Other contaminants may be contained; however, chemical compatibility tests should be performed. The C-B method provides some advantages over S-B slurry walls, in that no borrow materials are required, and C-B walls may be installed in soils with questionable stability, due to the relatively quick setting times of the slurry.

b. *Vibratory beam walls.*

(1) Description. The vibratory beam installation (VBI) method produces a thin slurry wall (Figure 3) by driving a wide flange beam, which has grout injection nozzles attached, to a predetermined depth and then extracting the beam and injecting the resulting void with a slurry mixture. Cement-bentonite is commonly used, although some bituminous grouts have been successfully used. Successive beam penetrations are overlapped to form a cutoff wall. The VBI method produces a cutoff wall approximately 75 to 125 mm (3 to 5 in.) wide, depending on the width of web on the beam or welded fin near the bottom of the beam.

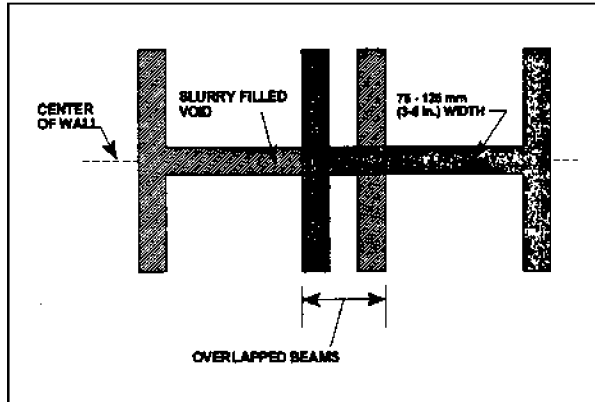

Figure 3. Vibratory beam wall-plan view

(2) Applicability. The VBI method is best suited for areas with flat topography and where loose granular soils are present. Beam penetration is difficult in stiff clays and rocky soils. The major advantage of the VBI method over conventional slurry wall systems is that no excavation of site soils is required, thus creating a safer work environment for site workers during installation. However, because a relatively thin wall is produced by the VBI method, it is not recommended as a primary barrier for contaminated groundwater. There are also concerns regarding wall continuity, as the tip location of the beam may vary, especially during deep penetrations. It may be difficult to determine when a key layer has been reached as well. VBI walls should be considered for use in conjunction with a groundwater removal system or for diverting clean groundwater around a contaminated site.

*c. Sheet pile walls.*

(1) Description. Interlocking sections of steel sheet pile are driven to a predetermined depth and may key into a subsurface aquiclude consisting of clay or another relatively impermeable horizon. Steel sheet pile cutoff walls are considered to be a somewhat permeable groundwater barrier. Each section interlocks with an adjacent section. The connection between sections may initially be a pathway for groundwater migration. This leakage may be reduced naturally with time as fines are trapped in the connection. If the piles are driven in material with little or no fines, the connections may never completely seal. Leakage in joints may also be sealed artificially by being filled with impermeable material. Various sheet configurations are available in varying weights.

It is difficult to key steel sheet pile into hard rock, and keys should preferably be made in clay.

(2) Applicability. The major advantage of using sheet piling is that no excavation is required. The disadvantages are the lack of an effective seal of the pile connections and problems with pile corrosion. Sheet piles are typically driven in soils that are loosely packed and predominately sand and gravel in nature. Piling longevity depends on groundwater characteristics. For steel piles, pH is of particular importance. If the pH of the groundwater is in the range of 5.8 to 7.8, sheet piles can last up to 40 years; however, a pH as low as 2.3 can shorten the lifetime to 7 years or less.

*d. Grout curtains.*

(1) Description. In general, grouting is the injection of one of a variety of special grouts into soil or rock, thus greatly decreasing the soil's permeability. The injection process involves drilling holes to the desired depth and injecting grout under pressure by using special equipment. To produce a curtain wall, a line of holes is drilled in single or double staggered rows and grouting is then accomplished. The spacing of the injection holes is site specific, depending on site soil characteristics, and is determined by the penetration radius of the grout out from the holes. To form a continuous wall, grout injected from adjacent holes should touch along the entire depth of the hole. When carried out properly, this process can produce a curtain or wall that can be an effective groundwater barrier.

(2) Applicability. In general, grout curtain walls are expensive and may not produce acceptable results for most HTRW groundwater containment situations. Because of this, pressure grouting is used primarily to seal voids in porous or fractured rock, such as below a slurry wall installation.

*e. Deep soil mixing.*

(1) Description. Deep soil mixing has been used to install vertical barriers. An auger is rotated into the soil while injecting various slurries, thus creating a column of low-permeability soil. A continuous wall is thus created by overlapping the columns of treated soil.

(2) Applicability. In general, the advantages of deep soil mixing are the minimal handling of contaminated soils during installation, and when compared to a vibratory beam wall, a thicker wall. Some concerns with the technique are wall continuity, (due to variances in column overlap), and ensuring that the key layer has been reached and penetrated.

f. *Geomembrane walls.*

(1) Description. One of the latest innovations from the geosynthetic industry is the use of geomembranes (Figure 4) made of high density polyethylene (HDPE) sheeting for vertical barrier walls. Geomembranes may be installed directly into softer soils with a vibratory hammer, or for deeper installations, the geomembranes are used to complement either S-B or C-B walls. When placed in a pre-excavated trench, the geomembrane panels may line one side of the trench, installed either with a vibratory hammer or mounted on a steel frame and inserted into the trench. Another technique is to line both sides and the bottom of the trench by draping the geomembrane panels into the trench by using ballast material. The geomembrane panels are typically 1.5 to 3 mm (60 to 120 mils) thick, with each sheet interlocking to the preceding panel.

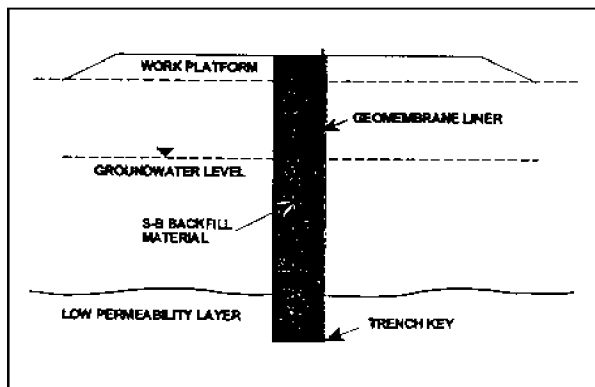

Figure 4. Slurry trench with geomembrane liner

Depending on soil conditions, walls may be constructed to a depth of 30 m (100 ft). Interlocks are sealed from leakage by the installation of a joint seal.

(2) Applicability. The use of geomembranes as a vertical barrier wall provides an excellent barrier to groundwater movement. Geomembranes installed as shallow sheet piles are not able to penetrate particularly stiff or rocky soils and, thus, are very dependent on site soil conditions and are limited in depth.

Geomembranes used in conjunction with slurry walls provide lower hydraulic conductivities for the completed wall; however, the additional cost of the geomembrane installation must be considered. It may be necessary to run compatibility tests between site contaminants and the proposed sheeting materials.

g. *Soilsaw™ walls.*

(1) Description. The Soilsaw™ barrier system (Figure 5) can form a vertical barrier wall which might be best described as a mixed in place wall. Various slurries or grouts may be used to mix with in situ soils by means of a jetting pipe which has grout jets located at regular intervals along the bottom of the pipe. The jetting pipe is attached to a mechanical crawler machine which is able to reciprocate the pipe along its length through a stroke equal to the spacing of the grouting jets. The jetting pipe is supplied with high pressure (3,500 N/cm<sup>2</sup> (5,000 psi)) slurry from separate mixing and pumping equipment.

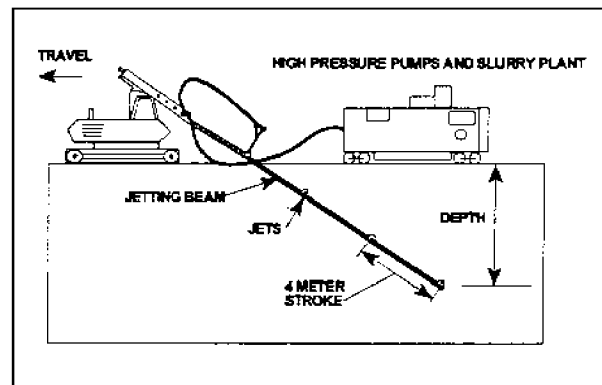

Figure 5. Soilsaw™ barrier system

When the system is operating, the soil under the jetting pipe is liquefied along the entire length of the jetting pipe, and the beam sinks into the ground under its own weight. As the pipe reaches its working depth (approximately 45 deg), the crawler begins to travel at a rate which enables the jetting beam to maintain the proper depth. Present equipment is capable of forming a cutoff wall which is approximately 300 mm (12 in.) wide.

(2) Applicability. Currently, the Soilsaw™ method is in the research and development phase. While not yet commercially available, it is planned to be used commercially in the future. The Soilsaw™ method is best suited for soils which are fairly uniform with occasional rocks and debris present. Small

rocks or cobbles are incorporated into the wall, while larger rocks are pushed out into the surrounding soil. Various grouts, such as bentonite, cement/bentonite, cement/flyash/bentonite, may be utilized, depending on the contaminant in the groundwater which must be contained. Currently, the working depth of the Soil-saw™ method is about 9 m (30 ft); however, it is expected that larger equipment may be able to construct a wall up to 30 m (100 ft) in depth. Advantages of this system include no trench spoils to handle, a continuous barrier wall, and high production rates. Disadvantages of the system are relatively high mobilization costs, reduced efficiency in hard cohesive soils, inability to key into hard rock layers, and large rocks or boulders in the path of the wall installation.

*h. Permeable reactive barriers.*

(1) Description. One of the most recent innovations in vertical barriers are permeable reactive barriers (PRB). A PRB is unique in design when compared to other vertical barriers since it involves the construction of a permeable reaction surface which can be placed across the path of a groundwater plume to permit groundwater to flow through the wall while degrading contaminants in situ or sorbing them. Contaminants can be degraded by chemical or biological processes or held in place by physical processes such as sorption or cation exchange. A typical PRB might be 15 to 60 m (50 to 200 ft) long, 1 to 5 m (3 to 15 ft) wide and installed to depths of up to 15 m (50 ft). The actual depth of the wall will be the saturated interval plus several feet to account for groundwater fluctuations and hydraulic control. The bottom of the wall ideally is keyed into an impermeable layer to maintain hydraulic control. In some configurations, it is envisioned that the lateral hydraulic control would be achieved by using conventional vertical barriers such as sheet pile walls. Sheet piles or other vertical barriers could be tied into the PRB and used to funnel groundwater through the reactive area which is referred to by some as a gate. In this manner, all of the contaminated water of interest will flow through the passive treatment zone.

(a) Chemical. The most common chemical reactions involve either redox changes or precipitation. An example of the redox reaction is the use of granular zero-valent iron to degrade halogenated hydrocarbons. The zero valent iron is oxidized and releases two electrons which appear to dehalogenate many halogenated hydrocarbons (including, but not

limited to, perchlorethylene (PCE), trichlorethylene (TCE), and dichlorethylene (DCE)) which are commonly found as contaminants in groundwater at hazardous and toxic waste (HTW) sites. There are other forms of iron and other metals and materials that can also be used in PRB for specific classes of contaminants. The material emplaced in the central core of the trench is often composed of 50- to 100-percent granular iron with the remainder being clean silica sand of similar grain size. In addition to the granular iron zone, there is often a zone on either side which consists of gravel or coarse sand to assist in maintaining hydraulic control.

(b) Biological. In these PRBs, the wall consists of a material that will enhance biodegradation by indigenous species in the aquifer. This might involve the introduction of a permeable substrate such as peat or wood chips to remove nitrate contamination. As the water flows through the PRB, denitrification reactions enhance the removal of the nitrates. In other circumstances, one can add substances to enhance redox conditions or to add other required nutrients for the bacteria such as adding oxygen or nitrate to enhance the biodegradation of benzene, toluene, ethylbenzene, and xylenes (BTEX) compounds.

(c) Physical. These processes include a number of sorption reactions for both organic and inorganic chemicals as well as ion-exchange reactions. The principal limitation of sorptive barriers is their finite capacity and the possibility of breakthrough when the capacity is exceeded. The reactive material would have to be excavated and disposed of in a manner consistent with regulatory requirements. Depending on the nature of the reactive material and the sorbed contaminants, the material may be expensive to dispose of or require regeneration. Additional clean material would then have to be reinstalled. A sound treatability study and knowledge of waste disposal requirements are critical when proposing this kind of barrier.

(2) Applicability. Complete site characterization data is critical to the successful design and construction of a PRB. It is critical to understand site geology, hydrogeology, and aquifer geochemistry before implementing this technology. Basic hydrogeological information such as the groundwater flow direction and velocity must be supplemented by more detail about seasonal fluctuations in head which, in turn, affect flow direction and velocity. Fluctuations in

seasonal groundwater flow directions and velocities are critical to wall performance. It is imperative that all of the contaminated water flows through, not around, the treatment zone. The PRB has a fixed location, and changes in these parameters will limit its effectiveness if the residence time is decreased and permits some of the contaminants to flow through untreated. Detailed geological data along the proposed PRB site is required to evaluate whether hydraulic control is achievable. For most sites the total depth of the PRB is limited to approximately 15 m (50 ft), and it is necessary to document the depth to the aquitard which the wall will key into and determine the aquitard's physical characteristics. Detailed site stratigraphy using a cone penetrometer or other continuous sampling technology is also necessary to show the potential effects of site heterogeneity on contaminant migration with respect to the location chosen for the PRB.

(a) Clogging of the wall by precipitants or coatings may, after a time, decrease the permeability and require the replacement of the treatment media. There is no good database on wall performance in this area, and it is impossible to predict with certainty how quickly a wall may need to be replaced. Geochemical data will assist in determining in situ redox conditions and chemical parameters that might affect the speed with which redox reactions take place and whether or not the proposed reactions will be affected by site chemistry. The major ions can also affect the speed at which precipitation reactions will take place and, thus, the time it takes for the reactive surface to become coated or clogged. Treatability and/or pilot studies need to be carried out with site waters to assess the needed thickness of the barriers for each site. Each compound has a different degradation rate, and aquifer geochemistry may also affect the performance of the wall.

(b) The most important criteria for the design of the PRB is that the contaminants are destroyed or sorbed as they move passively through the treatment zone. The exact method of emplacement will vary depending on the reactive substance to be emplaced and any requirements to maintain hydraulic control. A major consideration during emplacement is to ensure that the barrier has no significant heterogeneities which may serve as a preferential flow path. Alternative materials and methods of emplacement are also being developed including cassettes or other removable devices to allow easy access to the reacting agent. Because of the generally greater widths of

the PRBs as compared to slurry walls, there are additional potential problems with excavating and maintaining trench stability.

## B-5. Civil Design

Common civil design features for all vertical barrier wall projects which should be considered are described below.

*a. Site access routes.* Both public and private access routes to the site need to be investigated to ensure they can handle the construction traffic. The Contractor should be required to maintain any access routes including post-construction rehabilitation, if necessary. Aggregate surfaced roads may need to be built to allow access of construction vehicles or for operation and maintenance of the barrier wall. Aggregate surfaced roads should be designed in accordance with TM 5-822-12. Several U.S. Army Corps of Engineers guide specifications are available for the construction of roadways.

*b. Decontamination facility.* The Contractor must decontaminate all vehicles and equipment which enter the exclusion zone or contamination reduction zone. The contract documents should address the requirements for a decontamination facility and for the treatment and disposal of rinsate water. The final disposition of the decontamination facility should also be addressed. The Contractor should be required to submit a plan as part of the Site Health and Safety Plan which describes vehicle, equipment, and personnel decontamination procedures.

(1) Design criteria. The decontamination facility typically consists of 150 to 300 mm (6 to 12 in.) of granular material underlain by a protective geotextile and a geomembrane 1.0 mm (40 mils) in thickness. More elaborate designs may be used if the decontamination facility will be operated for a significant period of time. To minimize the volume of decontamination water, a temporary cover should be used to shed rainfall when the facility is not in use. Rinsate water is collected by gravity into a polyethylene or precast concrete storage tank which is typically about 3 m<sup>3</sup> (100 ft<sup>3</sup>) in volume. Treatment and disposal of the rinsate water and sediments should be in accordance with all state and Federal regulations. Federal disposal regulations are described in 40 CFR Parts 260-268. Rinsate water is typically disposed of after onsite treatment or is transported to an offsite

**ETL 1110-1-163**  
**30 Jun 96**

treatment facility. If the decontamination water and sediments are defined as hazardous wastes and are to be taken offsite, the Contractor must manifest the materials in accordance with 49 CFR 100-180 and 40 CFR 263. The materials must be transported by a certified hazardous waste hauler and the treatment, storage, and disposal facility (TSDF) must have the appropriate EPA and state permits. The Contractor should submit the names of all haulers and TSDF facilities proposed for use. Chemical test results, manifests, land disposal restriction (LDR) notification forms, and certifications of final treatment/disposal should also be submitted. See EP 200-1-2 for more detailed information on this subject.

*c. Security fencing.* A chainlink security fence is often used at the site boundary. The fence normally has a standard single outrigger with three strands of barbed-wire on the outrigger. The fence fabric should be a minimum of 1.8 m (6 ft) in height. USACE guide specification CEGS-02831 should be used in the contract documents to specify fencing requirements.

**B-6. Potential List of Drawings**

Provided below is a list of potential drawings that should be included in the contract documents. Not all drawings will be applicable to every project.

Cover Sheet

Index of Drawings

Abbreviations

Legend

Vicinity Map

Location Map

Existing Site Conditions (including utilities)

Test Pit and Boring Location Plan

Contractor Access Plan

General Plan

Horizontal and Vertical Control

Removal Plan

Electrical Distribution Plan

Site Control Plan

Grading Plan

Vertical Barrier Wall Profiles

Vertical Barrier Wall Typical Sections

Vertical Barrier Wall Plan View Along Centerline

Erosion Control Plan (Temporary)

Slurry Wall Corner Details

Working Platform Cross Section

Traffic Crossing Cross Section

Wash-down Area Cross Sections and Details  
(Decon Pad)

Monitoring Well Details

Piezometer Details

Chain Link Fence Details

Chain Link Gate Details

Project Right-of-Way Map

Record of Borings (Geological Profile Sheets)

Borrow Area Grading Plan, Sections and Soil  
Test Data

New Utility Drawings

New Access Road Profiles and Sections

Dewatering Plan

Extraction Wells

Injection Wells

Extraction Trench

## APPENDIX C: VERTICAL BARRIER WALL DESIGN CHECKLIST

### C-1. Vertical Barrier Wall Design Checklist

The purpose of this checklist is to prompt the designer or reviewer to consider all aspects of design. All major areas of design are covered by the checklist. However, the designer or reviewer must refer to the narrative and other references for detailed design criteria.

#### a. *Predesign investigations.*

##### (1) Field surveys and record searches.

- a Have existing documents (Remedial Investigation, Feasibility Study, etc.) been reviewed? Y\_\_N\_\_N/A\_\_
- a Have recent and historical aerial photographs been obtained? Y\_\_N\_\_N/A\_\_
- a Have design or as-built drawings of the existing site conditions been obtained? Y\_\_N\_\_N/A\_\_
- a Has current topographic mapping of the site, preferably CADD generated with 0.3048-m (1-ft) contour intervals, been obtained? Y\_\_N\_\_N/A\_\_
- a Does topographic mapping identify all surface features (e.g., fences, trees, and buildings)? Y\_\_N\_\_N/A\_\_
- a Have existing monitoring wells, piezometers, etc. been surveyed and horizontal coordinates and vertical elevations determined? Y\_\_N\_\_N/A\_\_
- a Has horizontal and vertical control been established and documented? Y\_\_N\_\_N/A\_\_

- a Have utilities been researched, identified, located, and mapped? Y\_\_N\_\_N/A\_\_
- a Have boundary surveys been conducted for both the project site and impacted adjoining properties? Y\_\_N\_\_N/A\_\_
- a Has a property (deed) search of the site and adjoining property been performed? Y\_\_N\_\_N/A\_\_
- a Has access for offsite monitoring been secured? Y\_\_N\_\_N/A\_\_
- (2) Geological investigations.
  - a Have the limits of contamination been determined? Y\_\_N\_\_N/A\_\_
  - a Has material excavatability been evaluated? Y\_\_N\_\_N/A\_\_
  - a Have groundwater conditions been evaluated including water levels, flow directions, contaminants present and groundwater chemistry? Y\_\_N\_\_N/A\_\_
  - a Has the depth and consistency of the aquiclude been determined along the vertical barrier wall alignment? Y\_\_N\_\_N/A\_\_
  - a Have the subsurface geologic conditions been characterized? Y\_\_N\_\_N/A\_\_
- (3) Vertical barrier wall selection.
  - a Have various vertical barrier walls been evaluated for use? Y\_\_N\_\_N/A\_\_



*b. S-B slurry wall design.*

(1) General.

a Do the contract documents adequately specify material and installation requirements? See guide specification CEGS-02444. Y\_\_N\_\_N/A\_\_

(2) Pre-design issues.

a Have borings been taken along the proposed alignment of the slurry wall? Y\_\_N\_\_N/A\_\_

a Have adequate borrow sources been identified? Y\_\_N\_\_N/A\_\_

a Do the specifications require all borrow materials be tested for contamination? Y\_\_N\_\_N/A\_\_

(3) Compatibility/optimization testing.

a Have several types of bentonite been obtained? Y\_\_N\_\_N/A\_\_

a Has an adequate supply (40 L (10 gal) each) of groundwater and tap water been obtained for the compatibility testing? Y\_\_N\_\_N/A\_\_

a Has an adequate supply (50 Kg (100 lbs)) of backfill material been collected? Y\_\_N\_\_N/A\_\_

a Is the proposed testing program adequate to optimize the mix design and determine the compatibility of the backfill mixture with the contaminants present at the site? Y\_\_N\_\_N/A\_\_

(4) Geotechnical design.

a Does the slurry wall alignment adequately surround the contaminated groundwater plume or hot spot? Y\_\_N\_\_N/A\_\_

a Is the slurry wall alignment clearly shown on the drawings? Y\_\_N\_\_N/A\_\_

a Is there an adequate aquiclude which the slurry wall will key into? Y\_\_N\_\_N/A\_\_

a Is the depth of the slurry wall clearly shown on the drawings? Y\_\_N\_\_N/A\_\_

a Is the wall thickness a minimum of 900 mm (36 in.)? Y\_\_N\_\_N/A\_\_

a Is a work platform needed due to the slope of the ground surface (2 percent max slope)? Y\_\_N\_\_N/A\_\_

a Is the work platform at least 12 m (40 ft) wide? Y\_\_N\_\_N/A\_\_

a Has trench stability been considered during design? Y\_\_N\_\_N/A\_\_

a Is the site layout area adequate for contractor staging, material, and equipment storage? Y\_\_N\_\_N/A\_\_

a Are stockpile locations shown on the drawings? Y\_\_N\_\_N/A\_\_

a Has a clay plug over the completed wall been adequately designed? Y\_\_N\_\_N/A\_\_

a Have equipment crossing zones been adequately designed? Y\_\_N\_\_N/A\_\_

(5) Construction quality control.

a Are Contractor qualifications outlined in the specifications? Y\_\_N\_\_N/A\_\_

- |   |   |
|---|---|
| <p>a Are requirements for bentonite, water, bentonite slurry, and backfill materials outlined in the specifications? Y__N__N/A__</p> <p>a Are trench excavation requirements outlined in the specifications? Y__N__N/A__</p> <p>a Are backfill placement requirements outlined in the specifications? Y__N__N/A__</p> <p>a Are requirements for initial backfill placement described in the specifications? Y__N__N/A__</p> <p>a Are quality control testing requirements described in the specifications? Y__N__N/A__</p> <p>a Will post-construction testing be performed on the slurry wall? Y__N__N/A__</p> <p>(6) Vegetative cover.</p> <p>a Is a vegetative cover applicable at this site? Y__N__N/A__</p> <p>a Are locally adapted perennial plants specified? Y__N__N/A__</p> <p>(7) Instrumentation.</p> <p>a Has instrumentation been specified to monitor groundwater levels or settlement of the slurry wall? Y__N__N/A__</p> <p>(8) Groundwater monitoring and control.</p> <p>a Is a groundwater extraction system to be utilized in conjunction with the slurry wall? Y__N__N/A__</p> <p>a Have the regulatory requirements for groundwater monitoring been defined? Y__N__N/A__</p> | <p>a Have existing wells been evaluated for use as monitoring points? Y__N__N/A__</p> <p>a Do the specifications address existing monitoring wells that will be impacted by construction (i.e., abandonment and extension)? Y__N__N/A__</p> <p>a Do the contract documents adequately specify material, installation, and monitoring requirements? See guide specification CEGS-02671, "Ground-Water Monitoring Wells?" Y__N__N/A__</p> <p>(9) Final grading requirements.</p> <p>a Has a final grading plan been established? Y__N__N/A__</p> <p>c. <i>Civil design.</i></p> <p>a Have site access routes been addressed in the contract documents? Y__N__N/A__</p> <p>a Are staging areas identified on contract documents? Y__N__N/A__</p> <p>a Have phasing requirements been addressed in the contract documents? Y__N__N/A__</p> <p>a Have utility requirements been specified? Y__N__N/A__</p> <p>a Are decontamination pad design, operation and disposal requirements specified? Y__N__N/A__</p> <p>a Are security fence requirements addressed in the contract documents? See guide specification CEGS-02831, "Chain-Link Fence." Y__N__N/A__</p> |
|---|---|

**ETL 1110-1-163**  
**30 Jun 96**

a Are the limits of clearing and grubbing shown on the drawings? Y\_\_N\_\_N/A\_\_

a Has disposal of cleared and grubbed material been addressed? Y\_\_N\_\_N/A\_\_

a Have clearing and grubbing been addressed in the contract documents? See guide specification CEGS-02110, "Clearing and Grubbing." Y\_\_N\_\_N/A\_\_

*d. Health and safety.*

a Have health and safety issues been addressed in the contract documents? See guide specification CEGS-01110, "Safety, Health and Emergency Response." Y\_\_N\_\_N/A\_\_

*e. Chemistry.*

a Have chemistry requirements been adequately addressed in the contract documents? See guide specification CEGS-01450, "Contractor's Chemical Quality Control." Y\_\_N\_\_N/A\_\_

*f. Operation and maintenance requirements.*

a Have groundwater monitoring criteria been addressed? Y\_\_N\_\_N/A\_\_

a Do the contract documents adequately address monitoring and inspection issues for the vertical barrier wall? Y\_\_N\_\_N/A\_\_

a Do the contract documents adequately address maintenance and repair issues for the vertical barrier wall? Y\_\_N\_\_N/A\_\_